

WILD NOTIONS:
PRESERVATION OF HISTORIC BUILDINGS IN OREGON WILDERNESS

by
CHARLOTTE M. HELMER

A THESIS

Presented to the Historic Preservation Program,
and the Graduate School of the University of Oregon
in partial fulfillment of the requirements
for the degree of
Master of Science

March 2020

APPROVAL PAGE

Student: Charlotte M. Helmer

Title: Wild Notions: Preservation of Historic Buildings in Oregon Wilderness

This thesis has been accepted and approved in partial fulfillment of the requirements for the Master of Science degree in Historic Preservation by:

Marsha Weisiger Chairperson

Rick Minor Member

and

Kate Mondloch Interim Vice Provost and Dean of the Graduate School

Original approval signatures are on file with the University of Oregon Graduate School.

Degree awarded March 2020.

© 2020 Charlotte M. Helmer

This work is licensed under a Creative Commons
Attribution 4.0 International Public License.



ABSTRACT

Charlotte M. Helmer

Master of Science

Historic Preservation

March 2020

Title: Wild Notions: Preservation of Historic Buildings in Oregon Wilderness

There is a common misperception that historic sites cannot be maintained once they are included in a wilderness designation. This conflict ultimately does a disservice to both heritage and wilderness resources. To that end, this thesis provides a baseline inventory of all known historic buildings managed by the U.S. Forest Service in Oregon wilderness, along with a set of condition assessments that direct attention towards specific maintenance needs. This study demonstrates how preservation projects can be applied in wilderness and further encourages the Forest Service and its partners to value and sustain these historic places. Ideally, the agency will continue to protect wild places, but in a manner that sustains connections to communities that once lived and worked within these landscapes. The physical acts of restoring and visiting these historic sites offer an unmatched opportunity for the public to engage and understand the paradoxical, intertwined relationships between people and wilderness.

ACKNOWLEDGMENTS

Foremost, I am sincerely grateful to Marsha Weisiger, Rick Minor, and Shannon Sardell of the University of Oregon for their mentorship throughout this endeavor. I also thank University of Oregon staff members Kristin Geiger and Trever Bruhn for their guidance and encouragement and faculty members Gabrielle Harlan, Robert Melnick, Chris Enright, James Buckley, and Don Peting for their time and expertise.

It has been a privilege to work with staff of the USDA Forest Service, Pacific Northwest Region; I am thankful for their enthusiasm and their trust. Jeffery Walker provided leadership, funding, and encouragement. Charles Ruhsenberger shared qualitative and geographical data that describe the agency's facilities and helped build a geographic information system to identify properties located in wilderness areas. Becky Blanchard and Claire Fernandes shared information about the history and management of wilderness areas in Oregon and completed a Minimum Requirements Decision Guide. During site visits, I relied on Heritage and Wilderness staff including Cara Kelly, Cathy Lindberg, and Dylan McCoy of the Willamette National Forest; Allie Wenzl, Deborah Ortiz, and Michael Dryden of the Mount Hood National Forest; and Sarah Crump, Tony King, and Sweyn Wall of the Wallow-Whitman National Forest. Additional help came from Forest Heritage Program Managers Penni Borghi, Kevin Bruce, Donald Hann, John Kaiser, Christopher Kelly, Allen Mandrill, and Melissa Schroeder.

The study was supported in part by an Oregon Heritage Fellowship. I thank Oregon Parks and Recreation staff for their support and expertise, especially Beth Dehn of the Oregon Heritage Commission and Jason Allen of the State Historic Preservation Office.

I am grateful to my colleagues and mentors at HistoriCorps, who also played a key role in this work. Executive Director Townsend Anderson and Director of Operations Jonas Landes administered the financial and logistic aspects of fieldwork funded by a Forest Service grant. Jonas also shared his expertise in planning preservation work in wilderness areas, joined me for a trip into the Mount Hood Wilderness to assess buildings and structures and refine fieldwork methods, and edited condition assessments. Workforce Manager Liz Rice recruited volunteers to join me in the field. Volunteers Hayli Reff, John Milliken, Gina Drew, and John Helmer with Restore Oregon staff Dan Everhart, Lydia Ness, and Victoria Hensley contributed 150 hours on backcountry site visits.

Finally, I wish to thank craftspeople and project managers who shared their valuable expertise and leadership during preservation projects in remote, backcountry, and wilderness settings. This group includes Ellen Gage, Jason Benson, Larry Lack, Katherine Wonson, Laura Kim, and Tim Devine of the National Park Service; and HistoriCorps Field Staff John Bales, Kyle Bernard, Sarah Mees, Denis Moran, Spencer Siebeck, Basil Webb, Kat Weisbecker, and Jonathan Williams.

These communities continue to inspire me through our dedicated work in wild and historic places. Thank you all.

DEDICATION

For my parents who are, as we say, a “lighthouse in the wilderness.”

TABLE OF CONTENTS

Chapter	Page
PREFACE	1
I. INTRODUCTION	3
II. LITERATURE REVIEW	17
III. HISTORY OF OREGON WILDERNESS.....	28
IV. INVENTORY AND ASSESSMENT METHODS.....	47
V. ARE PRESERVATION PROGRAMS EFFECTIVE IN WILDERNESS?.....	64
VI. HERITAGE AS REMEDY TO THE TROUBLE WITH WILDERNESS	89
APPENDIX A: MINIMUM REQUIREMENTS DECISION GUIDE	94
APPENDIX B: ASSESSMENT PROCEDURES.....	114
APPENDIX C: ASSESSMENT TOOLS	122
APPENDIX D: ASSESSMENT REPORTS	123
REFERENCES CITED	300

LIST OF FIGURES

Figure	Page
i. The Enchanted Valley Chalet in the Olympic Wilderness (NPS, 2014)	2
1.1. Map of wilderness areas nationwide. (Wilderness Connect, 2014).....	15
1.2. Map of wilderness areas in Oregon. (Wilderness Connect, 2014)	16
3.1. Map of wilderness designations in Oregon (Oregon Wild, 2009)	45
3.2. Map of proposed wilderness areas in Oregon (Oregon Wild, 2009)	46
4.1. Map of historic sites inventoried and assessed during this study	58
4.2. Map of historic sites assessed during this study	59
4.3. Visitors gathered at Bull of the Woods Peak in the Bull of the Woods Wilderness to view a solar eclipse from the path of totality in July 2017	60
4.4. Relative impact of a crew hiking to assess the Upper Sandy Guard Station in the Mount Hood Wilderness (Dan Everhart, 2017)	61
4.5. Relative impact a single person traveling in wilderness to assess historic sites including Elk Meadow Shelter and Mule Peak Lookout	62
4.6. Volunteers use tools to investigate and record conditions at historic sites in wilderness: McNeil Point Shelter (Jonas Landes, 2017); Waldo Mountain Lookout; Upper Sandy Guard Station; and Millard Ranger Station.	63
5.1. Good condition and active use represented by Waldo Mountain Lookout.....	83
5.2. Fair condition and sporadic use represented by Devil’s Peak Lookout.....	84
5.3. Poor condition and no use represented by the Upper Sandy Guard Station	85
5.4. Opportunities represented by Waldo Mountain Lookout vs. Kinzel Cabin.....	86
5.5. Opportunities represented by McNeil Point vs. Cooper Spur Shelter	87
5.6. Opportunities represented by Olallie Mountain vs. Mule Peak Lookout	88
6.1. Experiential values supported by historic sites in wilderness such as Waldo Mountain Lookout and Red’s Horse Ranch	93

LIST OF TABLES

Table	Page
1.1. Qualities of Wilderness Character.....	13
1.2. Framework of the National Register of Historic Places.....	14
5.1. Inventory of Historic Sites in Oregon Wilderness	77
5.2. Documents Provided by National Forests and SHPO.....	79
5.3. Building Types and Conditions.....	80
5.4. Use and Conditions	81
5.5. Preservation Conditions and Opportunities.....	82

PREFACE

This document is a welcome mile marker on a journey that I have not finished yet. When I applied to the graduate program in Historic Preservation at the University of Oregon, I knew that I wanted to investigate historic buildings in wilderness. I first came to the topic when I worked as an intern for the National Park Service at Olympic National Park in 2014. In fact, I learned about wilderness and historic preservation at the same time. The two are utterly intertwined in that park. As an intern, I split my time between archival research in the park offices, splitting cedar shakes with the backcountry carpenter, and hiking upriver to assess historic lookouts and guard stations. I also participated in a project to document and relocate the Enchanted Valley Chalet, pictured here on the following page. This image expresses the risks and opportunities offered by projects undertaken to preserve historic buildings in wilderness. Moreover, it illustrates the way that I think about these places. My attention is focused on the technical challenges that we encounter to maintain them, the people who do this remarkable work, and the rare skills that are required.



Figure i. The historic Enchanted Valley Chalet in the Olympic Wilderness of Olympic National Park, Washington, during a project to relocate the building away from an eroded bank of the Quinault River in 2014.

CHAPTER I

INTRODUCTION

There is a common misperception that the 1964 Wilderness Act has priority over the 1966 National Historic Preservation Act and that historic buildings and structures cannot be maintained once they are included within wilderness designations. This perceived conflict does a disservice to both heritage and wilderness resources. It drives resource managers to adopt an overly cautious or negligent approach to preservation, which almost inevitably results in the loss of historic resources over time. When that physical record of our history disappears, its absence facilitates false narratives and simplistic, irresponsible ideas of American wilderness that have persisted for decades.

There is a need for new research to encourage a future in which historic preservation plays an integral role in the management of wilderness areas. Previous books and theses used focused case studies, a qualitative approach, to examine the perceived conflict between wilderness and preservation. Case studies provide insight into the nuances of specific places and events. However, they provide dots on a map. If case studies are used to direct management plans and policies, it would be wise to understand the bigger picture as well.

No federal or state agencies and no stewardship groups have published an inventory of historic buildings in wilderness areas on a state-wide or regional scale.¹ It is even hard to find a comprehensive inventory of any one wilderness area. This is

¹ This assertion is based on the author's full review of relevant literature and discussions with U.S. Forest Service and National Park Service staff.

surprising, because surveys and inventories are essential components of most preservation programs. You have to know what you have, before you decide how to manage it. In stark contrast, wilderness stewards have made admirable efforts to collect data that describe the qualities of every wilderness area across the country, and these stewards continue to synchronize research efforts throughout the National Wilderness Preservation System.²

When survey information is out of date or unavailable, practices, policies, and laws are developed with scant information about their potential to affect a variety of historic resources across the country. Inventory projects are important tools for historic preservation because they provide a necessary foundation for the development of effective management plans. Without that data, it is hard to evaluate wilderness and heritage management practices within a single wilderness area and even harder to know if these practices have an accumulative effect throughout the National Wilderness Preservation System.³ In this study, new and comprehensive information forms a firm foundation for more proactive preservation work in the future by clarifying which heritage resources survive, what is lost, and what we may yet lose under current conditions.

² Documents and research tools collected at Wilderness Connect (wilderness.net) demonstrate the extent to which wilderness stewards successfully coordinate research efforts that capture useful data on a national scale.

³ For instance, the National Park Service has developed a practice of writing “wilderness character narratives” that determine, on a case by case basis, if historic resources will be protected in each wilderness area. From a preservation perspective, these narratives seem to privilege historic sites that reinforce mythologies about the culture and history of wilderness, but it is difficult to articulate which heritage sites are protected or neglected by these narratives without a baseline survey to provide that context.

By law, each federal agency that administers the Wilderness Act must also administer the National Historic Preservation Act, yet historic places in wilderness are chronically neglected. Under the National Historic Preservation Act, these agencies must identify, monitor, and manage cultural resources in their jurisdiction.⁴ Each agency already manages historic resources outside of wilderness, yet federal heritage programs commonly avoid or overlook wilderness sites. Unfortunately, the misperception that human history is inappropriate in wilderness has prevented preservation projects that are actually beneficial and feasible.

Every management task that brings tools, crews, and building materials into wilderness areas also brings an intriguing set of challenges related to protecting wilderness character and historic resources. Some of these challenges are technical and practical, such as making sure that crews use appropriate tools and work safely. Other challenges are essentially cultural. Cultural opposition typically comes from (1) the assumption or conviction that preservation work is inherently harmful to wilderness character, (2) first- or second-hand knowledge of wilderness projects that left a wreckage of financial costs, lawsuits, and public outrage in their wake, or (3) a sincere aesthetic appreciation for the way in which nature reclaims old buildings and structures left in situ. Moving forward, these dynamics can improve if participants understand and respect both the technical and cultural contexts of their work.

⁴ Pertinent responsibilities for managing cultural resources are codified in Section 110 of the National Historic Preservation Act of 1966 and also in agency-specific policies such as Forest Service Manual 2309.12, *The Heritage Program Management Handbook*.

Essential preservation strategies that professionals routinely apply outside of wilderness are equally applicable and appropriate within wilderness. These strategies include: (1) surveys and inventories to identify and evaluate resources; (2) condition assessments, preservation plans, and treatment plans to monitor conditions and coordinate appropriate changes; and (3) hands-on maintenance and restoration projects to address deterioration and sustain uses. The technical components of these tasks can be accomplished without harming wilderness character, but the cultural components have deterred us from trying. Culturally, we could strive for a more proactive approach simply by reasserting that historic preservation programs should be applied in wilderness areas.

To that end, this thesis supports future preservation actions by describing the current state of historic resources in Oregon's wilderness areas and proposing technical strategies to improve their condition. There are two components. An inventory project answers relatively basic questions about what resources we have and where they are. A set of condition assessments provides more detailed information to aid a discussion about management practices and strategies for future work.

Specifically, this study pursues four research questions: (1) Which wilderness areas contain historic buildings and structures? (2) Which architectural types and historical contexts do they represent? (3) Has their condition been maintained? (4) Given limited financial resources, what priorities should inform management decisions among federal agencies that are responsible for these heritage sites?

It is important to note that this study is focused on historic buildings and structures but excludes many other significant resources that intersect wilderness areas,

such as trails, roads, fences, landscapes, and archeological sites. In fact, many of the buildings and structures included in this study also intersect with prehistoric and historical archeological features and landscapes, that reveal a rich history of previous communities and activities. These features are worthy of consideration and preservation, but they are excluded from this thesis out of a practical need to manage the project scope. Future research should address these resources with input from practitioners who have relevant professional qualifications.⁵

This study refers to historic “buildings and structures” as property types classified and defined for the National Register of Historic Places. Buildings are constructions that were principally made to shelter humans or their animals. Structures are functional constructions that were made for purposes other than shelter. Buildings and structures are the exclusive topic of this work because of their potential value as useful facilities, their relative visibility and tendency to attract public interaction, and the technical aspects of maintaining them in good condition.

This study focuses on wilderness areas managed by the USDA Forest Service in Oregon, within the federally designated National Wilderness Preservation System (Figure 1.1). Oregon includes forty-eight federally designated wilderness areas (Figure 1.2). Altogether, these designations apply to more than 2.5 million acres, approximately four percent of all land in Oregon. The Forest Service administers forty-one of these wilderness areas across more than 2.25 million acres. Two other federal agencies divide

⁵ It would be inappropriate and minimally helpful to study archeological sites without relevant credentials. For instance, the Secretary of the Interior's Standards for Profession Qualifications specify different qualifications for Historical Architects, Historians, Preservationists, and Archeologists, and most State Historic Preservation Offices limit public access to their files that pertain to archeological sites.

the remaining acreage in Oregon. The Bureau of Land Management manages nine wilderness areas, encompassing 0.25 million acres, and the U.S. Fish and Wildlife Service manages two wilderness areas, with only 608 acres. The National Park Service manages substantial wilderness acreage in other states but has no responsibility for any wilderness areas in Oregon.⁶

In this study, an emphasis on the Forest Service is appropriate because that agency has a uniquely important role in managing Oregon wilderness. No other federal land management agency is responsible for more wilderness acres or historic buildings and structures in the state. Furthermore, the agency's own history is intertwined with the American wilderness movement. This focus on Oregon, and the Forest Service, offers a variety of historic sites and a long, rich history to reckon with.

The Wilderness Act of 1964 and the National Historic Preservation Act of 1966 were both born out of the same impulse to protect wild places and historic sites from rampant development before their aesthetics and experiential values were lost entirely. The Wilderness Act protects sites that possess the “qualities of wilderness character.” The National Historic Preservation Act protects sites that meet a set of criteria for eligibility and a set of characteristics for integrity. Both laws have similar ideals about protecting against short-term thinking, slowing or restricting development, and preserving opportunities and experiences that seemed to be vanishing in the modern era. Federal agencies must address both of these laws simultaneously.

⁶ “Advanced Wilderness Search,” Wilderness Connect, <http://wilderness.net/practitioners/wilderness-areas/search.php>.

Practitioners who are trained in cultural resource management but are less familiar with wilderness management may find it useful to think of “wilderness character” as a parallel to “characteristics of integrity,” which are used to evaluate the relationship between the physical condition and historical integrity of historic places.⁷ The specific qualities of wilderness character are different and specific to each wilderness area, so “wilderness narratives” provide a nuanced definition of wilderness character as it is applied to each wilderness area.⁸

The Wilderness Act of 1964, Section 2(c), provides the Definition of Wilderness: “A wilderness, in contrast with those areas where man and his works dominate the landscape, is hereby recognized as an area where the earth and its community of life are untrammeled by man, where man himself is a visitor who does not remain.” The specific qualities of wilderness character are also derived from Section 2(c):

[Wilderness] is protected and managed so as to preserve its natural conditions and which (1) generally appears to have been affected primarily by the forces of nature, with the imprint of man's work substantially unnoticeable; (2) has outstanding opportunities for solitude or a primitive and unconfined type of recreation; (3) has at least five thousand acres of land or is of sufficient size as to make practicable its preservation and use in an unimpaired condition; and (4) may also contain ecological, geological, or other features of scientific, educational, scenic, or historical value.

⁷ U.S. Department of the Interior, National Park Service, National Register of Historic Places, *How to Apply the National Register Criteria for Evaluation*, 2002.

⁸ U.S. Department of the Interior, National Park Service, Wilderness Character Integration Team, *Keeping It Wild in the National Park Service: A User Guide to Integrating Wilderness Character into Park Planning, Management, and Monitoring*, 2014.

In the modern framework of wilderness management, the definition is elaborated to five qualities of wilderness character that federal agencies manage in designated wilderness areas. These are the (1) “untrammeled,” (2) “undeveloped,” (3) “natural” qualities, (4) “opportunities for solitude or primitive and unconfined recreation,” and (5) “other features of value,” which includes cultural and historical resources (Table 1.1). The word untrammeled means free or unrestrained and it refers to natural processes in a wilderness context. The word undeveloped refers to mechanization and new construction. These words do not mean that the land has no human history, nor do they require that historic resources should be left to decompose and disappear.

Meanwhile, the National Historic Preservation Act of 1966 establishes procedures to identify and manage historic properties that have significance and integrity. Section 106 of that act requires federal agencies to evaluate and moderate projects that cause an adverse effect to historic resources. In this regard, historic preservation becomes a consideration in every federal action. Section 110 of the act further states that federal agencies will proactively identify and manage the historic resources within their jurisdictions.⁹ This act is procedural. It does not guarantee specific outcomes for specific properties, but it does create a protocol of professional standards, practices, and tools to protect historic resources. Properties are historic if they meet at least one of four Criteria

⁹ From the point of view of federal agencies and their responsibilities, there is no difference between how the agency manages a property that is listed on the National Register versus one that is merely eligible for listing. Section 106 of the NHPA states that any federal agency that has jurisdiction over a project that involves federal funds or permits shall “take into account the effect of the undertaking on any district, site, building, structure, or object that is included in or eligible for inclusion in the National Register.” Section 110 states that all federal agencies shall “establish a preservation program for the identification, evaluation, and nomination to the National Register of Historic Places, and protection of historic properties.”

for Evaluation related to their historical “significance” and also retain physical “integrity” (Table 1.2).

In 2014, the National Park Service's Wilderness Character Integration Team made progress to integrate wilderness and cultural resource management by clarifying that neither law supersedes the other.¹⁰ The report, *Keeping It Wild in The Park Service: A User Guide to Integrating Wilderness Character into Park Planning, Management, and Monitoring*, states:

Resolving these challenges requires a common framework for understanding wilderness and cultural resource values and laws. [...] The framework presented here is that: (1) Cultural resource laws apply inside wilderness. (2) Cultural resources may be part of wilderness character. (3) The Wilderness Act’s mandate to preserve wilderness character applies to managing cultural resources in wilderness.

There are several implications of this framework. First, cultural resources need to be inventoried and evaluated so a determination of their significance can be established. Second, cultural resource and wilderness staffs need to discuss which cultural resources rise to the level of a “character-defining feature” (a phrase used in historic preservation) for that wilderness. Third, cultural resources that do not rise to this level are still managed under the legal obligations of cultural resource laws. Fourth, the management prescription for a particular cultural resource inside wilderness needs to consider its role in history and in the wilderness,

¹⁰ U.S. Department of the Interior, National Park Service, Wilderness Stewardship Division, *Keeping It Wild in the National Park Service: A User Guide to Integrating Wilderness Character into Park Planning, Management, and Monitoring* (2014), 90-1. “In fact, no federal law has priority over another unless explicitly stated in congressional legislation and neither wilderness nor cultural resource laws state that they have a priority over the other. Therefore, all cultural resource laws apply to cultural resources in wilderness, just as the Wilderness Act also applies.”

requiring discussion between wilderness and cultural resource staffs to reach an informed and transparent decision.¹¹

This framework described in *Keeping It Wild* provides an important premise for future collaboration and preservation work in wilderness.

Our heritage is insufficiently protected wherever resource managers are unable to simultaneously perceive their cultural resources in a wilderness context and their wilderness landscape in a cultural context. Many historic resources have been neglected or removed because they appeared to detract from wilderness values. Despite that conflict, it is now clear that the Wilderness Act describes historic resources as a component of wilderness character. Preservation and wilderness values are not inherently incompatible, yet each side has demanded different terms to achieve compatibility. In the future, there should be new opportunities to apply historic preservation programs within wilderness, and it is time for historic preservationists to explore and develop their skills to conduct projects within that context. This research thus provides rare, essential data that can be useful to theorists and practitioners alike, and it describes methods that federal stewards and citizens can apply to help improve the way we manage these resources.

¹¹ U.S. Department of the Interior, National Park Service, Wilderness Stewardship Division, *Keeping It Wild in the National Park Service: A User Guide to Integrating Wilderness Character into Park Planning, Management, and Monitoring* (2014), 91.

Table 1.1. Qualities of Wilderness Character

<p>The central mandate of the Wilderness Act is to preserve wilderness character.</p>	<p>1. Untrammeled</p>	<p>Wilderness is essentially unhindered and free from modern human control or manipulation. This quality is monitored to assess whether management of a wilderness is trending over time toward more or less human manipulation of plant communities, fish and wildlife populations, insects and disease, soil and water resources, and fire processes.</p>
<p>The definition of wilderness character is derived from Section 2(c) of the Act, which begins:</p>	<p>2. Natural</p>	<p>Wilderness ecosystems are substantially free from the effects of modern civilization. In contrast to the Untrammeled Quality, which monitors actions that manipulate or control ecological systems, the Natural Quality monitors the effects on wilderness ecosystems from actions as well as external forces.</p>
<p>“A wilderness, in contrast with those areas where man and his works dominate the landscape, is hereby recognized as an area where the earth and its community of life are untrammeled by man, where man himself is a visitor who does not remain.”</p>	<p>3. Undeveloped</p>	<p>Wilderness retains its primeval character and influence and is essentially without permanent improvement or modern human occupation. This quality is monitored to assess whether a wilderness is becoming more developed over time, such as by exhibiting increasing evidence of physical infrastructure, or if there is more prevalent use of mechanization, such as helicopters and chainsaws.</p>
<p>Wilderness managers monitor and preserve five Qualities of Wilderness Character.</p>	<p>4. Solitude, or Primitive and Unconfined Recreation</p>	<p>Wilderness provides outstanding opportunities for solitude or primitive and unconfined recreation. This quality is monitored to assess whether management of a wilderness is trending over time towards protecting outstanding opportunities for specific, unique recreational experiences. Visitors may desire other experiences than those described in the Wilderness Act, but those experiences are not part of the legislated requirement to preserve wilderness character</p>
<p>Wilderness managers monitor and preserve five Qualities of Wilderness Character.</p>	<p>5. Other Features of Value</p>	<p>Wilderness may contain other features of ecological, geological, scientific, educational, scenic, or historical value. Monitoring this quality focuses on specific, tangible features and how their condition changes over time. This quality is not required for every wilderness area. If features exist that are truly integral to wilderness character, then this quality is required.</p>

Source: Peter Landres, Steve Boutcher, and Elizabeth Mejicano, “Wilderness Character Monitoring Technical Guide,” (Fort Collins, CO: U.S. Department of Agriculture, Forest Service, Rocky Mountain Research Station, 2019).

Table 1.2. Framework of the National Register of Historic Places

<p>Aspects of Integrity</p> <p>The National Register recognizes properties that are historically significant and also have integrity. Integrity is a property's ability to convey its significance. Integrity is sometimes subjective but always grounded in an understanding of the property's physical features and how they relate to its historical significance.</p>	<p>Location</p> <p>Design</p> <p>Setting</p> <p>Materials</p> <p>Workmanship</p> <p>Feeling</p> <p>Association</p>	<p>The place where the historic property was constructed or the place where the historic event occurred.</p> <p>The combination of elements that create the form, plan, space, structure, and style of a property.</p> <p>The physical environment of a historic property.</p> <p>The physical elements that were combined or deposited during a particular period of time and in a particular pattern or configuration to form a historic property.</p> <p>The physical evidence of the crafts of a particular culture or people during any given period in history or prehistory.</p> <p>A property's expression of the aesthetic or historic sense of a particular period of time.</p> <p>The direct link between an important historic event or person and a historic property.</p>
<p>Criteria for Evaluation</p> <p>Properties possess historical significance if they have integrity and meet one or more of these four Criteria related to their history.</p>	<p>Criterion A</p> <p>Criterion B</p> <p>Criterion C</p> <p>Criterion D</p>	<p>Associated with events that have made a significant contribution to the broad patterns of our history.</p> <p>Associated with the lives of persons significant in our past.</p> <p>Embodies the distinctive characteristics of a type, period, or method of construction; represents the work of a master; possesses high artistic values; or represents a significant and distinguishable entity whose components may lack individual distinction.</p> <p>Have yielded, or may be likely to yield, information important in prehistory or history.</p>

Source: U.S. Department of the Interior, National Park Service, National Register of Historic Places, "National Register Bulletin No. 15: How to Apply the National Register Criteria for Evaluation," (Washington D.C.: U.S. Government Printing Office, 2002).

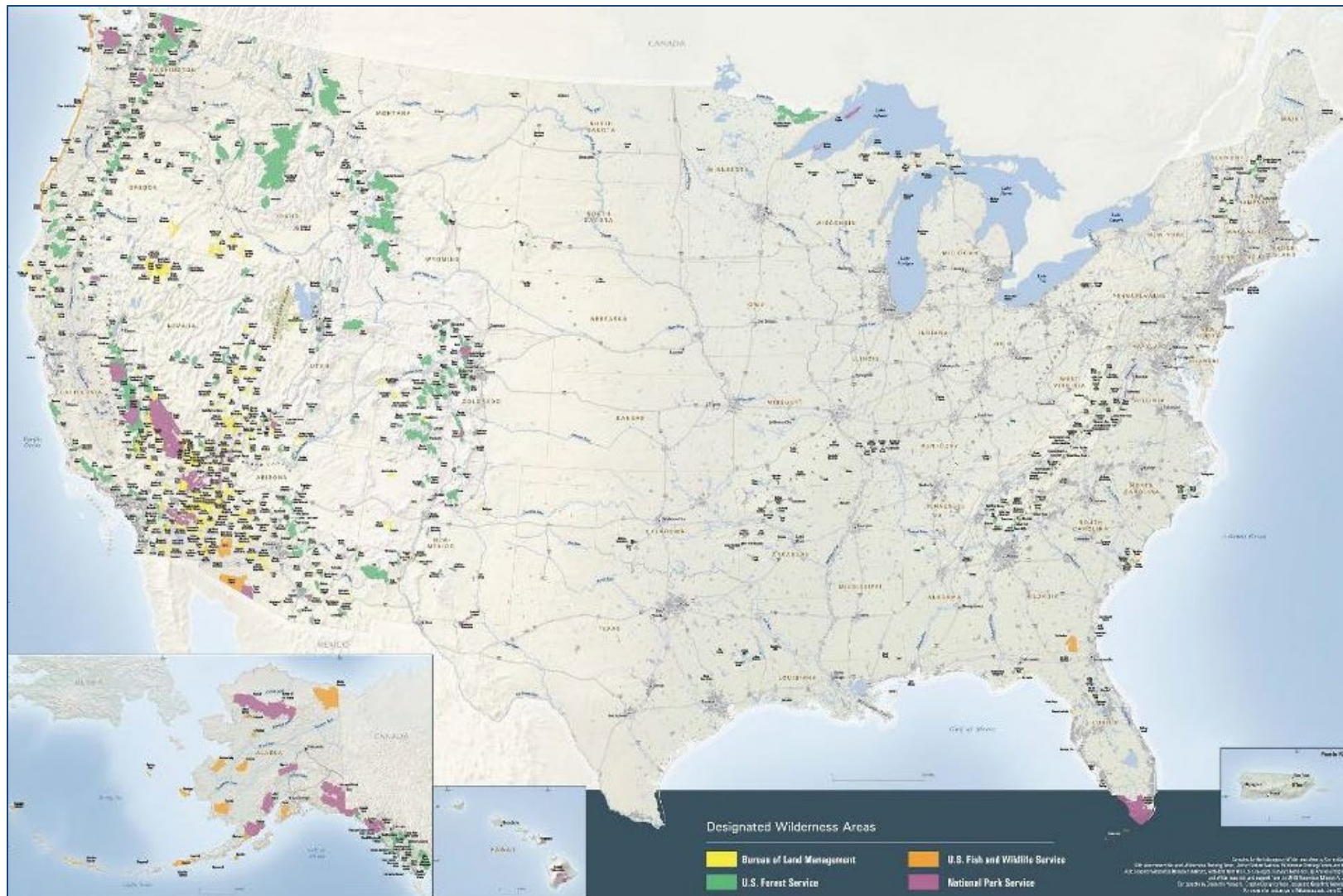

Figure 1.1. Wilderness areas managed by the U.S. Fish and Wildlife Service (orange), Forest Service (green), Bureau of Land Management (yellow), and National Park Service (purple) nation-wide. (Wilderness Connect, 2014).

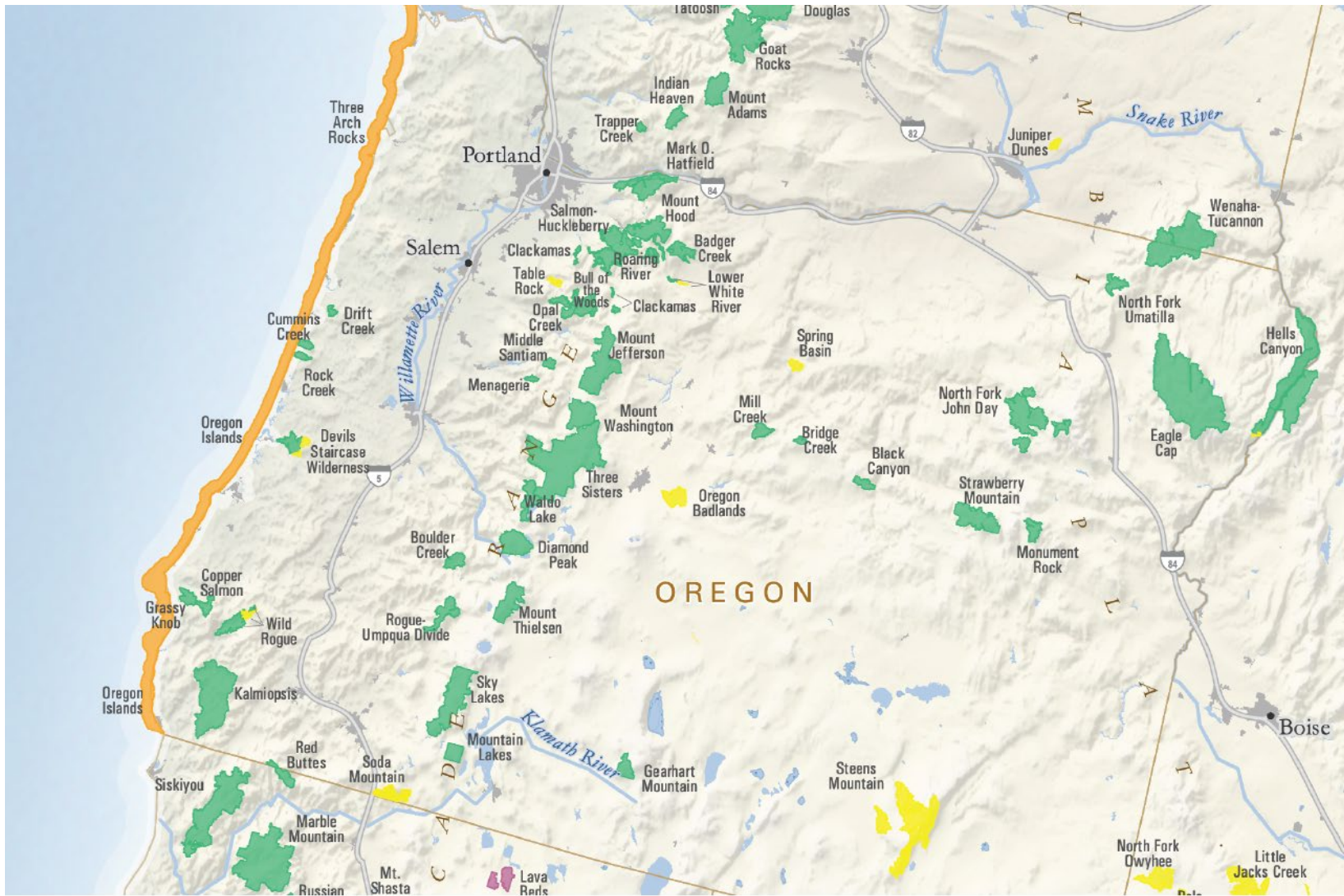

Figure 1.2. Wilderness areas managed by the U.S. Fish and Wildlife Service (orange), Forest Service (green), Bureau of Land Management (yellow), and National Park Service (purple) in Oregon. (Wilderness Connect, 2014).

CHAPTER II

LITERATURE REVIEW

Within designated wilderness areas in the United States, many cultural resources have been altered, neglected, or removed because they appeared to detract from wilderness values. The National Park Service's Wilderness Character Integration Team reported a common misperception that the Wilderness Act has priority over other laws, including the National Historic Preservation Act, which results in the idea that these cultural resources should disappear.¹ Even in situations where all participants agree that wilderness values and heritage values are compatible, there is a persistent struggle to reach a balance, or compromise, without one camp yielding to the other. The result is that we have a rich literature of case studies and theory to draw upon, and yet there is also more work to do before participants reach a consensus.

In 1927 historian Bernard DeVoto wrote about the cultural power of the American West and its frontier from his perspective in “Footnote on the West”:

The West, like all of America, was once frontier. It was frontier, however, longer and more vividly than any part, and indeed you may still find portions of it where, alone in America, the frontier persists. [...] Its memory is dominant in the West today. The frontier has created an extraordinary number of myths, and they have got themselves accepted as realities. [...] Alas, they have worked their way into our thinking, and we

¹ U.S. Department of the Interior, *Keeping It Wild in the National Park Service*, 90. “In fact, no federal law has priority over another unless explicitly stated in congressional legislation and neither wilderness nor cultural resource laws state that they have a priority over the other. Therefore, all cultural resource laws apply to cultural resources in wilderness, just as the Wilderness Act also applies.”

see ourselves not as we are but as the myths have made us out to be. The result is only sometimes amusing, but it is always harmful to us and especially to our future.²

DeVoto stated this contention decades before the Wilderness Act brought about our current framework for managing wilderness and the National Historic Preservation Act codified our processes for evaluating and protecting cultural resources. Most of the buildings and structures included in this study of Oregon wilderness were not constructed until ten to forty years after his writing. Nonetheless, DeVoto observed a persistent cultural force and described it in a way that resonates in wilderness management to this day.

Writing fifty years after Bernard De Voto, the environmental historian William Cronon provided a new, updated critique of the mythologies that persist in how people perceive and value wilderness. In an essay titled “The Trouble with Wilderness,” Cronon wrote:

The more one knows of its peculiar history, the more one realizes that wilderness is not quite what it seems. Far from being the one place on earth that stands apart from humanity, it is quite profoundly a human creation—indeed, the creation of very particular human cultures at very particular moments in human history.³

Cronon, who is a board member of the Wilderness Society, has encouraged historians and wilderness stewards to integrate nature and culture in wilderness and thereby remedy

² Bernard DeVoto, “Footnote on the West,” *Harper’s Monthly Magazine*, November 1927, in Bernard DeVoto, *DeVoto’s West: History, Conservation, and the Public Good*, ed. Edward K Muller (Athens, OH: Swallow Press, 2005), 10.

³ William Cronon, “The Trouble with Wilderness; or, Getting Back to the Wrong Nature,” in *Uncommon Ground: Rethinking the Human Place in Nature* (New York: W. W. Norton, 1995), 6.

flawed myths about frontier histories and untouched landscapes. In particular, he makes a case for "historical wilderness" — places that celebrate and retain stories and physical evidence related to the relationship between people and wild nature. Cronon's included an option to preserve human artifacts that previous wilderness management practices would have erased.⁴

In *Dispossessing the Wilderness: Indian Removal and the Making of the National Parks* historian Mark David Spence further explains that American wilderness traditions have a long history of racism directed towards native peoples, and that this gets to the heart of the "troubles" that Cronon describes. These troubles come from a strict separation of nature and humanity, and flawed notions about people who are part of, or apart from, humanity.⁵ Spence writes:

[Early] Americans generally conceived of the West as a vast "Indian wilderness," and they rarely made a distinction between native peoples and the lands they inhabited. Consequently, the earliest national park advocates hoped to protect "wild" landscapes and the people who called these places home. Preservationist efforts did not succeed until the latter half of the nineteenth century, however, when outdoor enthusiasts viewed wilderness as an uninhabited Eden that should be set aside for the benefit and pleasure of vacationing Americans. The fact that Indians continued to hunt and light purposeful fires in such places seemed only to demonstrate a marked inability to appreciate natural beauty. To guard against these

⁴ William Cronon, "The Riddle of the Apostle Islands: How Do You Manage a Wilderness Full of Stories?" *ORION Magazine* 22, no. 3 (May/June 2003), 36-42.

⁵ Mark David Spence, *Dispossessing the Wilderness: Indian Removal and the Making of the National Parks* (Oxford University Press: 2000), 4.

“violations,” the establishment of the first national parks necessarily entailed the exclusion or removal of native peoples.⁶

Looking to the future, Spence writes that “cooperation on cultural issues ... could revolutionize the way all Americans experience the wilderness” by revealing that modern wilderness is “predicated on Indian dispossession” and embracing a more complex, historically accurate definition that includes usable or inhabitable wilderness, which would imply that nature and culture are “deeply intertwined, if not inseparable.”⁷ Spence encourages a future in which Americans no longer “idolize wilderness as a nonhuman landscape” and instead “provide important new lessons about the degree to which cultural values and actions have always shaped the natural world.”⁸

In her thesis, “A Case for Storied Landscapes,” cultural resources manager Laura Kirn writes that wilderness advocates are gradually and litigiously creating an environment in which they are exempt from the professional practices of historic preservation.⁹ Kirn studied this conflict within the National Park Service and found that the “historical, statutory, and practical management contexts [of wilderness] limit the effectiveness of traditional historic preservation principles and practices, such as those embodied in the [National Historic Preservation Act] and the National Register of Historic Places.” In its present form, wilderness is “a profoundly distinct land

⁶ Spence, *Dispossessing the Wilderness*, 5.

⁷ Spence, *Dispossessing the Wilderness*, 140.

⁸ Spence, *Dispossessing the Wilderness*, 140.

⁹ Laura Kirn, “A Case for Storied Landscapes: Wilderness and Historic Preservation” (MS thesis, Goucher College, Baltimore, 2013), 250.

classification” that will likely result in the “inevitable loss” of significant cultural resources over time.¹⁰

Meanwhile, recreation specialist Molly Michelle Ryan found that a lack of preservation activity neglects the educational and cultural value of wilderness itself. In her thesis, “The House that Smokey Built,” Ryan asserts that “by saving and recording examples of human activity in wilderness we can actually better understand the environment before us and our relationships to that environment.” Similarly, Kirn found that historic places in wilderness areas typically relate to the stories of “everyday people in extraordinary places.” Accordingly, they expand our understanding of “past and present human relationships to the land.”¹¹

In her thesis, “Old Buildings and the New Wilderness,” geographer Kerry Gathers studied a case at Cumberland Island, Georgia, in which the watchdog nonprofit organization Wilderness Watch sued the National Park Service over preservation actions undertaken within a designated wilderness area. The court that presided over the case, *Wilderness Watch v. Maniella*, concluded that a land managing agency, in this case, the National Park Service, should administer the National Historic Preservation Act *within* the terms of the Wilderness Act. In this case, wilderness and heritage advocates and resources managers “agreed that wilderness conservation and historic preservation are not

¹⁰ Kirn, “A Case for Storied Landscapes,” 273.

¹¹ Kirn, “A Case for Storied Landscapes,” 326.

inherently incompatible but at the same time demanded very different terms to achieve compatibility.”¹²

Why is it hard to reach that compromise? In answer, Gathers reiterates Cronon, Spence, and others with her depiction of a kind of dissonance within the Wilderness Act. Gathers writes that the act codifies the “poetry of Thoreau’s and Muir’s spiritual wilderness experiences” yet undermines “their power” by “denying social construction as the primary force in defining wilderness.”¹³ The Wilderness Act values visitors’ perceptions or interpretations of the land’s history, regardless of accuracy, and it reinforces a perception that wilderness is untouched and frozen in time. Gathers reminds us that wilderness “as we know it in this country, in this historical moment,” is “wholly dependent” on political mechanisms, judicial rulings, and legal boundaries.¹⁴

Wilderness and preservation communities each have cultural values that shape the interaction of their respective legal tools. Gathers writes that the Wilderness Act is a substantive law built with mandates and prohibitions to enforce inaction and only allow actions that directly reinforce wilderness character. Meanwhile, the National Historic Preservation Act is a procedural law that promotes and encourages consideration of historic preservation, “but demands little” and does not guarantee specific results.¹⁵ At Cumberland Island, Gathers found that “the Park Service’s inability to maintain all of Cumberland’s historic structures, inside and outside of the wilderness, is due to

¹² Kerry Gathers, “Old Buildings and the New Wilderness: The Politics of Conservation in Cumberland Island, Georgia” (MA thesis, University of Georgia, 2006), 2.

¹³ Gathers, “Old Buildings and the New Wilderness,” 41.

¹⁴ Gathers, “Old Buildings and the New Wilderness,” 41.

¹⁵ Gathers, “Old Buildings and the New Wilderness,” 80.

substantial budget deficiencies, not limitations on access”¹⁶ It seems likely that this principal applies more broadly to federal agencies where neglect is a symptom of toothless historic preservation laws and the high financial costs of historic preservation work, compared to the Wilderness Act with its relatively inexpensive and enforceable preference for inaction.

In part because the Wilderness Act is so strong, the search for compromise has led some researchers to reframe inaction as a viable strategy that unites wilderness and historical values. Inaction, or minimal action, is such a central tenant of wilderness management that it makes sense to try and reconcile historic preservation with a form of management that involves watching historic resources decay. However, I have not found any treatise that makes a compelling argument to let all buildings in wilderness waste away. Thus far, these arguments only provide a way to rationalize and excuse neglect in cases where neglect is already the status quo. These conversations side-step more important and interesting ideas about proactive preservation strategies in wilderness.

The historian James Feldman introduced the term “rewilding” to wilderness management environmental history in his writing about the Apostle Islands of Lake Superior.¹⁷ At the time, rewilding was principally applied within the context of conservation biology, but Feldman used the term to describe a long history of management decisions that gradually shaped the Apostle Islands from a developed, occupied landscape to a patch-work of zones dedicated to historic resources or

¹⁶ Gathers, “Old Buildings and the New Wilderness,” 79.

¹⁷ James Feldman, *A Storied Wilderness: Rewilding the Apostle Islands* (Seattle: University of Washington Press, 2007).

wilderness. Feldman’s analysis includes a deep appreciation for rare places on the islands that are managed as a kind of interstitial space, unique from areas that are managed primarily for historical interpretation or primarily for wilderness character. The rewilding areas allow land managers to work with an emphasis on balancing ecological, wilderness, and heritage goals.

Feldman’s evocation of “rewilding” is nuanced. He emphasizes the importance of balancing wilderness and heritage values at each site rather than apply on consistent treatment throughout. He writes:

Narratives of pristine wild nature or even nature recovering from abuse are easier to tell than those of rewilding. But such stories miss the chance to draw deeper, richer meanings from the islands, quieting the conversations about the relationship between nature and history so central to understanding rewilding landscapes. They also fail to provide answers to the most challenging management questions posed by these places—maintaining, and nurturing wild, healthy environments, balancing competing demands on resources, mitigating visitor impact on places valued for both natural and cultural reasons. These challenges can only be met by keeping past uses and ways of valuing the islands always in front of us.¹⁸

Since his writing, other researchers and managers have seized the word “rewilding” and narrowed it’s meaning to describe a decision to let historic resources become overgrown, decay, collapse, and otherwise deteriorate over time through exposure to environmental conditions.

¹⁸ Feldman, *A Storied Wilderness*, 21.

In “A Case for Storied Landscapes,” Kirn characterizes rewilding as a “treatment strategy,” akin to the *Secretary of the Interior’s Standards for Preservation, Rehabilitation, Restoration, and Reconstruction*, except that this treatment “protects the untrammled character of wilderness by avoiding any form of modern human control or manipulation of the natural or cultural environment.”¹⁹ This definition strays from Feldman’s intent and, if it were applied to all cultural resources in wilderness, this version of rewilding would not improve conditions on the ground. I worry that this version of rewilding primarily re-introduces the status quo— neglect — as if it has been a legitimate heritage strategy all along. I appreciate strategies proposed by Kirn, and others, for the way that they may succeed in making preservation work for wilderness. These are important discussions. However, rewilding, moldering, and other forms of neglect do not adequately address the challenge of *retaining* historic sites, which was part of Feldman’s vision for the Apostle Islands.

In *Paradox of Preservation*, Laura Watt studies the preservation of historic working landscapes in wilderness areas of the Point Reyes National Seashore and considers how the National Park Service has used moldering and demolition as tools to “rewild” historic landscapes. Since 1964, the National Wilderness Preservation System has grown and incorporated more areas that are impacted by human developments, with the understanding that they could *become* idyllic if managed to restore their wilderness character. Watt has no objection to these designations, but she asserts that current management practice at Point Reyes “distorts public understanding of the area's past,

¹⁹ Kirn, “A Case for Storied Landscapes,” 298.

perpetuating the myth of wilderness as ahistorical and purified of all traces of civilization.”²⁰

Watt points out that these practices disguise the managing agency’s presence and its actions on the land. She writes that this is not accidental, but rather, it “represents a strategic reconfiguration of the landscape to bring it closer in appearance to public and agency expectations of what a wilderness area ‘ought’ to look like.”²¹ This process disguises the fact that designated wilderness areas are still subject to human use, simply “for a different purpose, and by different people.”²² As remedy, Watt asserts that land management agencies could help heal a rift between nature and culture by “encouraging the public to understand the human history of natural areas” while continuing to manage for wilderness values.²³ Wilderness character would be preserved but not enhanced.

The most intriguing part of Watt's book is her proposed strategy to integrate wilderness areas with their history. The park has used historical signs to achieve that goal, but Watt asserts that signs amplify sporadic historical features and actually make it more challenging to see history where it is unsigned. Instead, she proposes to identify “specific types of wilderness, according to the degree to which they have been inhabited and used in the past and then manipulated to take on a more wilderness-like appearance. The historic preservation field has such a continuum, in the form of standards for the treatment of historic properties.”²⁴ *The Secretary of the Interior’s Standards for the*

²⁰ Laura Watt, the *Paradox of Preservation: Wilderness and Working Landscapes at Point Reyes National Seashore* (Oakland: University of California Press, 2016), 57.

²¹ Watt, *Paradox of Preservation*, 56.

²² Watt, *Paradox of Preservation*, 69.

²³ Watt, *Paradox of Preservation*, 57.

²⁴ Watt, *Paradox of Preservation*, 69.

Treatment of Historic Properties identifies four treatments: Preservation, Rehabilitation, Restoration, and Reconstruction. Each treatment is appropriate to different preservation projects, depending on a property's condition, significance, function, and future management. The *Secretary of the Interior's Standards* lend complexity and nuance to processes that would be too restrictive otherwise. They reserve a purist approach for rare cases that warrant such treatment. Watt argues that we could escape the confining origin story of wilderness by giving equal attention to wilderness areas that we preserve, restore, or recreate.²⁵

In the end, it is helpful to return to Cronon's "Trouble with Wilderness" to remember that heritage and wilderness values overlap in significant ways. He writes that wilderness "is the ultimate landscape of authenticity [...] It is the place where we can see the world as it really is, and so know ourselves as we really are—or ought to be." Furthermore, he writes that if we resort to "simplistic opposition, we are almost certain to ignore the very subtleties and complexities we need to understand."²⁶ Authenticity is valued in historic preservation, too. Given our proclivity for delving into cultural nuances, challenging suspect legacies, and building resiliency for the future, historic preservationists may be well suited to help tell human stories in wilderness. The next question to consider is: what should historic preservationists learn from wilderness?

²⁵ Watt, *Paradox of Preservation*, 69.

²⁶ Cronon, "The Riddle of the Apostle Islands," 12.

CHAPTER III

HISTORY OF OREGON WILDERNESS

Heritage professionals who conduct work in wilderness should understand the significance of that context and ensure that their projects are conducted with appropriate tools and techniques, yet it can be hard to comprehend how individual projects conducted in wilderness might have an accumulative and significant impact on the vast, national wilderness system over time. In my experience, the inspiration to appreciate and protect wilderness comes from spending time in wilderness areas and also from studying their history. To that end, this chapter recounts the history of wilderness designations and wilderness management in Oregon, to help heritage professionals understand the context of their actions.

All of Oregon's wilderness areas are part of a National Wilderness Preservation System which was established by the Wilderness Act of 1964.¹ The Wilderness Act also tasked specific federal agencies with administering wilderness, established a process for adding future wilderness areas to the national system, and initially protected fifty-four wilderness areas throughout the United States. The act was not the first set of protections for American wilderness, but it was a major milestone and provided the essential framework for wilderness management that is still applied today. Since 1964, the National Wilderness Preservation System has been expanded to encompass more than 800 wilderness areas and more than 111 million acres across the United States.² The responsibility to manage wilderness now extends to the Department of Agriculture's

¹ The Wilderness Act, 16 U.S.C. §2 (1964). Other U.S. states manage parallel programs such as the California State Wilderness system established by the California Wilderness Act of 1984.

² Wilderness Connect, <https://wilderness.net>.

Forest Service as well as the Department of the Interior's National Park Service, Bureau of Land Management, and Fish and Wildlife Service.

The Wilderness Act initially established nine wilderness areas across 1.1 million acres in Oregon, but wilderness acreage in the state has continued to expand ever since that time with new designations applied throughout the state and entrusted to several federal agencies. The responsibility to manage federal wilderness in Oregon is borne primarily by the U.S. Forest Service, which manages forty areas and more than 2.48 million acres throughout the state. Other land management agencies play a smaller role. The Bureau of Land Management manages nine areas, more than 523,000 acres, primarily in central and eastern Oregon, while the Fish and Wildlife Service manages two areas, just 608 acres, off the Oregon coast. In total, Oregon now includes forty-eight wilderness areas that encompass more than 2.5 million acres, or roughly 4 percent of all land in the state (Figure 3.1).³

In Oregon, the Wilderness Act and all wilderness designations thereafter were forged in evolving political contexts influenced at both the national and local levels by a variety of federal agencies, private industry, and public advocacy groups. In *Drawing Lines in the Forest: Creating Wilderness Areas in the Pacific Northwest*, historian Kevin Marsh explains that the power to designate federal wilderness in Oregon originated in the Forest Service but was later transferred to the United States Congress when wilderness advocates lost faith in the agency's ability to uphold protective measures. Marsh therefore describes the Wilderness Act of 1964 as a defining moment when the Forest

³ Wilderness Connect, <https://wilderness.net>.

Service ultimately lost its autonomy to designate wilderness, but he also recounts a complex history that led up to that legislation and the impact that it ultimately made in the decades that followed.⁴

Young Wilderness, 1890 – 1945

The first designation to protect scenic values, natural resources, and recreation opportunities on federal lands in Oregon was ordered by President Grover Cleveland in 1886. In *The U.S. Forest Service in the Pacific Northwest: A History*, historian Gerald W. Williams recounts that the impetus for this designation began in 1885 when William G. Steel, a resident of Portland, visited Crater Lake and observed impacts made by the Department of the Interior's General Land Office through actions to sell forested land to homesteaders, timber companies, and miners and gift land for state schools, railroads, and wagon roads. Steel collaborated with Judge John B. Waldo of Salem to propose federal protections for the remaining forests around Crater Lake. As a result of their advocacy, the idea gained momentum, and President Grover Cleveland ultimately issued an order to end homesteading in ten townships around Crater Lake.⁵

Conservation advocates, including Steel and Waldo, continued to advocate for a much larger reserve that would encompass the entire crest of the Oregon Cascades. Meanwhile, conservation movements gained momentum throughout the nation, fueled by growing concern that public lands in the West were rapidly and recklessly becoming privatized under authorities granted by legislation such as the Donation Land Claim Act

⁴ Kevin Marsh, *Drawing Lines in the Forest: Creating Wilderness Areas in the Pacific Northwest* (Seattle: University of Washington Press, 2007).

⁵ Gerald W. Williams, *The U.S. Forest Service in the Pacific Northwest, a History* (Corvallis: Oregon State University Press, 2009), 38.

of 1850 and the Timber-Culture Act of 1873. In 1891, Congress passed the Forest Reserve Act, and under the premise of that law, conservation advocates in Oregon continued their efforts to expand protections in the Cascades.⁶

President Cleveland issued an order to establish the Cascade Forest Reserve in 1893, which encompassed 4,883,588 acres of the high Cascades in a continuous area that extended from the vicinity of Klamath Lake to the Columbia River Gorge. It included much of the area that advocates had proposed to protect, and it was substantially larger than any other reserve in the nation. The reserve was established to protect natural resources, and it had the effect of closing a large portion of the Cascade Range to homesteading while also regulating access for grazing and logging. Almost immediately, there were protests and proposals to allow more access within the reserve. In the early years, few resources were allocated to the Department of the Interior to manage forest reserves. As a result, protective restrictions were hardly enforced, and some private uses continued. Conservation advocates remained active in reasserting the need to protect scenic and recreation values in the reserve.⁷

In 1905, all forest reserves were transferred from the General Land Office of the Department of the Interior to the Department of Agriculture, and the newly established Forest Service assumed responsibilities for their management. All Forest Reserves were reclassified as National Forests. The young agency's holdings quickly expanded under

⁶ Williams, *U.S. Forest Service in the Pacific Northwest*, 38.

⁷ Williams, *U.S. Forest Service in the Pacific Northwest*, 41.

President Theodore Roosevelt's administration, and in 1908, the massive Cascade National Forest was divided into multiple national forests.

At this time, the term "wilderness" broadly meant uninhabited landscapes of sublime natural beauty, while wilderness preservation meant acknowledging and promoting aesthetic values above utilitarian uses or economic exploitation.⁸ Under Chief Forester Gifford Pinchot, the young Forest Service practiced a conservation ethic that balanced resource protections with other activities and uses on public lands. By the early 1920s, the Forest Service had permitted unprecedented levels of commercial development to support a variety of uses on the National Forests, and several iconic wilderness stewards, including Aldo Leopold, Arthur Carhart, and Robert Marshall, emerged within the agency's ranks to protect opportunities for primitive recreation.

Kevin Marsh characterizes the agency's leadership during this era as "an elite group of professionals" who made decisions on behalf of the public and were "a driving force for conservation and wilderness preservation."⁹ These men worked within the agency to protect wilderness qualities by identifying undeveloped areas, creating new land use designations, curbing road construction projects, and encouraging non-motorized recreation. They argued that protections served the agency's broader purpose by saving areas that the public demanded for recreation, while retaining productive forests in the Forest Service. At this time, the Forest Service was literally losing ground to the growing National Park Service in parts of the country where the public clamored for more recreational opportunities and protections for scenic areas.

⁸ Kirn, "A Case for Storied Landscapes," 21.

⁹ Marsh, *Drawing Lines in the Forest*, 36.

In 1929, the Forest Service codified or institutionalized a wilderness ethic through a set of standards called the L-20 Regulations.¹⁰ These regulations created a system of “primitive areas” that the Chief Forester could designate to limit some forms of development on public land. The agency further introduced a set of enhanced protections called the U Regulations in 1939. Under these regulations, the Secretary of Agriculture could designate large “wilderness areas” or smaller “wild areas” to prohibit logging and road construction. The Pacific Northwest Region used an additional classification for “limited areas” that were relatively safe from logging, mining, or road building, but had fewer protections than any of the other designations. Limited areas implied a probationary status that the regional office unofficially described as “wait and see.”¹¹

Robert Marshall, in his capacity as head of the National Division of Recreation and Lands for the Forest Service, surveyed Forest Service lands in the Oregon Cascades and proposed protective designations for undeveloped, high-alpine areas. In 1937, under Robert Marshall’s direction, the agency established the Three Sisters Primitive Area and the Mount Jefferson Primitive Area in the Willamette National Forest under the L-20 Regulations. Marshall intended that both designations would encourage conservation and recreation, and his survey trip preempted a competing proposal for a national park in the Oregon Cascades.

Throughout this era before the Wilderness Act, the Forest Service had sole discretion to establish protected areas, alter their boundaries, or remove protections altogether. The U Regulations required public hearings to alter designations, but the

¹⁰ Marsh, *Drawing Lines in the Forest*, 23.

¹¹ Marsh, *Drawing Lines in the Forest*, 27 and 39.

agency was not obligated to adjust its plans based on public comments. Private citizens, organizations, and industry representatives could address the agency's staff to influence their actions, but ultimately, the agency did not need to account for public opinion. The agency's own staff had created these early wilderness regulations, and it was assumed that they would continue to sustain and manage those protected areas without specific oversight.¹² This premise held for several decades but it began to unravel after World War II amidst a dramatic increase in timber production and recreation developments on public lands.

Mid-Century Wilderness, 1945 - 1965

Timber economies and public advocacy in the Pacific Northwest forests significantly shaped the future National Wilderness Preservation System. Before 1930, most timber from the Pacific Northwest came from public lands. That changed when timber prices peaked in the 1920s, timber ran out on private land, and then, ultimately, lumber companies were financially crippled by the Great Depression and lost their landholdings. After World War II, the Forest Service became a primary timber supplier to boost the logging and building industries and to provide housing and employment for a generation of Americans who came of age during the war. The Pacific Northwest was already the Forest Service's leading source for lumber, so the agency sought to expand its yield by extracting more material from Douglas fir trees in the relatively steep foothills of the Cascade Range. The Willamette National Forest quadrupled its timber sales between

¹² Marsh, *Drawing Lines in the Forest*, 24.

1945 and 1955. As the timber economy reached higher into the Cascades, it chewed at the edge of conservation lands, including the region's so-called "wait and see" lands.¹³

After World War II, the Forest Service's definition of wilderness diverged from public opinion as the agency's staff worked to accommodate significant demands for other uses on the National Forests. Kevin Marsh characterizes the agency in this era as tremendously self-confident, too prideful of its legacies, defensive of its expertise in timber management and wilderness management, and impervious to public influence. The agency was principally focused on providing building materials, roads, and facilities for public benefit, but these activities alarmed multiple popular movements that sought to protect environmental aesthetics, including historic preservation, conservation, and outdoor recreation. Citizen alliances grew quickly, and the next generation of wilderness leaders emerged outside the Forest Service as the agency undermined its former legacy of leadership and collaboration.¹⁴

The Forest Service had begun to reclassify "primitive areas" under the L20 Regulations with "wilderness" designations under the U Regulations, but that project stalled in the face of Robert Marshall's death in 1939 and then the onset of World War II. After the war, the agency resumed its review of primitive areas with a different set of priorities.¹⁵ In the Pacific Northwest, the Forest Service "released" commercially viable forests from wilderness protections and focused conservation efforts, such as they were, at high elevations where there was no commercial timber. For example, the agency reclassified the Three Sisters Primitive Area as a smaller Three Sisters Wilderness Area

¹³ Marsh, *Drawing Lines in the Forest*, 25.

¹⁴ Marsh, *Drawing Lines in the Forest*, 23.

¹⁵ Marsh, *Drawing Lines in the Forest*, 25.

in 1957, and to appease public opposition, the agency also designated two small “wild areas” on Mount Washington and Diamond Peak in the Cascades. The new boundary lines released accessible old-growth commercial timber at lower elevations for new roads and harvests. In this specific instance, the Forest Service’s disregard for ample public opposition “frightened wilderness advocates across the country,” according to Marsh.¹⁶

In another instance, the Forest Service offered to maintain *either* the Three Sisters Wilderness Area in the Central Cascades of Oregon *or* the Glacier Peaks Wilderness Area in the North Cascades of Washington.¹⁷ This tactic by the Forest Service taught wilderness advocates to lend equal weight to battles at the local and national level. Land deals that sacrificed undeveloped land for timber harvest appeared to betray the public’s trust, albeit in a manner that was legal because the Forest Service was empowered to act independently of public opinion.

Cultural and political shifts within the Forest Service therefore necessitated fundamental changes in the wilderness and conservation movements. Citizen conservationists around the country began to keep an eye on developments in the Cascade Range, and new leaders in the wilderness movement, including Olaus Murie and Howard Zahniser, visited Lane County, Oregon, in the 1950s to speak about the shared sentiment that caused people around the country to care about protections for the Three Sisters Wilderness Area.¹⁸ Marsh characterizes the wilderness movement of this era as reactive and defensive, as on-going conflicts between the Forest Service and the public revealed specific vulnerabilities in the existing systems for wilderness preservation.

¹⁶ Marsh, *Drawing Lines in the Forest*, 33.

¹⁷ Marsh, *Drawing Lines in the Forest*, 38.

¹⁸ Marsh, *Drawing Lines in the Forest*, 22.

Wilderness advocates began to envision a new system that could better withstand shifting priorities within any single federal agency.¹⁹ In fact, when Howard Zanhiser visited Lane County to participate in the Three Sisters debates, he was drafting a bill that would become the Wilderness Act.²⁰

Contemporary Wilderness, 1964 - present

The Wilderness Act of 1964 provided nine wilderness areas in Oregon, all managed by the Forest Service. These areas were the Three Sisters, Mountain Lakes, Mount Washington, Diamond Peak, and Mount Hood Wilderness in the western Cascade Range; the Gearhart Wilderness in the south-central high desert; the Eagle Cap and Strawberry Mountain wilderness areas in the northeast mountains; and the Kalmiopsis Wilderness in the southern Coastal Range.²¹ In the decades that followed, Congress acted on several occasions to create and expand new wilderness areas in Oregon. Congress established the Mount Jefferson Wilderness in 1968 as an evolution of the former Mount Jefferson Primitive Area. In 1970, it established the Oregon Islands and the Three Arch Rocks Wilderness areas within existing National Wildlife Refuges on the Oregon coast.²² Then followed the Hells Canyon National Recreation Area and its Hells Canyon Wilderness in 1975.²³ Throughout these decades, there was conflict between the Forest Service staff and wilderness advocates who wanted to apply divergent standards in the way they managed wilderness.

¹⁹ Marsh, *Drawing Lines in the Forest*, 32.

²⁰ Marsh, *Drawing Lines in the Forest*, 29.

²¹ Wilderness Connect, <https://wilderness.net>.

²² Wilderness Connect, <https://wilderness.net>. These were the first Oregon wilderness administered by the Department of the Interior Fish and Wildlife Service in Oregon.

²³ Wilderness Connect, <https://wilderness.net>.

According to Marsh, the Wilderness Act was established despite opposition from the Forest Service’s leadership, and as they proceeded to implement the act, Forest Service staff enforced a “purity doctrine,” which appeared to wilderness advocates to challenge or undermine the intent and spirit of the act. The “purity doctrine” was a strict standard that the Forest Service promoted based on ideals of a pristine landscape free of any evidence of human influences. According to Marsh, the agency’s leaders took “possessive pride” in their legacy as “keepers of the original wilderness preservation tradition” and genuinely felt that there was no need for a duplicate system that would impact their autonomy to balance wilderness management with other competing uses on the national forests.²⁴ They deliberately applied a high standard for roadless, undeveloped wilderness land to disqualify commercial forests that had any history of human impact. The agency also argued that accepting lands that were not pristine would dilute the quality of the entire wilderness system. Marsh characterizes this tactic as an effort by the Forest Service to maintain control over the definition of wilderness on its land.²⁵

In Oregon, these conflicts over the purity doctrine are reflected in the boundaries of the Mount Jefferson Wilderness. The Mount Jefferson Primitive Area (established in 1933) was among the first primitive areas that the Forest Service reevaluated under the Wilderness Act of 1964, and the agency proposed excluding two areas: Whitewater Valley, which included a logging road, and Marion Lake, which had been developed for recreation. Marsh recounts that Forest Service staff even plunged a new road into Whitewater Valley in an apparent attempt to make the area ineligible for wilderness

²⁴ Marsh, *Drawing Lines in the Forest*, 72.

²⁵ Marsh, *Drawing Lines in the Forest*, 74.

designation. That tactic worked. When Congress established the Mount Jefferson Wilderness in 1969, it excluded the Whitewater Valley but included Marion Lake. As Forest Service staff administered the new Mount Jefferson Wilderness area, they enforced the purity doctrine by removing developments and ending historical uses in the vicinity of Marion Lake, although this was not necessary under the wilderness designation.²⁶

Furthermore, the Forest Service traditionally managed forest resources through a philosophy of “multiple use” to gain the greatest benefit while serving the widest array of interests, but the agency’s interpretation of “multiple use” became a source of conflict with the American people in the mid-twentieth century.²⁷ Robert Marshall and his contemporaries had thought of wilderness as a use that could balance with compatible uses on shared land. His successors in the mid-twentieth century preferred to compartmentalize each use to its landscape (e.g., wilderness restricted to the high country and lowlands reserved for timber harvest), and they called wilderness a “single-use” designation that it was too restrictive for areas that were suitable for multiple uses. Wilderness advocates argued for the Forest Service to apply the multiple use concept on a larger scale and further cited “multiple uses” to criticize the agency’s habit of allowing timber management plans to overrule other resource management plans.²⁸ Congress finally resolved the debate by passing the Multiple Use and Sustained Yield Act of 1960, which included wilderness within the specific definition of “multiple uses.”

²⁶ Marsh, *Drawing Lines in the Forest*, 66.

²⁷ Marsh, *Drawing Lines in the Forest*, 44.

²⁸ Williams, *U.S. Forest Service in the Pacific Northwest*, 238.

Laws such as the Multiple-Use Sustained-Yield Act of 1960, the Wilderness Act of 1964, the National Historic Preservation Act of 1966, the National Environmental Policy Act (NEPA) of 1969, and the National Forest Management Act of 1976 were driven by a political force that Williams describes as “a dramatic shift in the environmental attitudes and values of the American public.”²⁹ In the 1960s and 1970s, Congress passed a series of laws to require that each land management agency’s “elite groups of professionals” would engage and address public opinion through established processes that were intended to make federal land management significantly more democratic than it was before. Over time, and after numerous lawsuits and appeals, some of these laws did fundamentally change the Forest Service’s priorities and methods for resource management. Although the Wilderness Act crucially democratized the process to designate wilderness areas, new procedural laws that followed, such as the National Environmental Policy Act, also played a critical role in making the process to protect and manage wilderness more democratic.

In the 1970s and 1980s, Congress also passed several laws designating new wilderness areas in a manner that gradually changed the practical application of wilderness ideology across all federal agencies that manage the National Wilderness Preservation System. For instance, the Eastern Wilderness Areas Act of 1975— although it had no direct effect in Western states —significantly changed the character of the National Wilderness Preservation System as a whole. The Forest Service had previously concluded that none of its holdings east of the Mississippi River were eligible for the National Wilderness Preservation System because they were too developed or otherwise

²⁹ Williams, *U.S. Forest Service in the Pacific Northwest*, 227.

impacted by the evidence of generations of human activity. With the Eastern Wilderness Act, Congress directed the Forest Service and Park Service to relax their definitions of pristine wilderness in order to increase protection for environmental and recreational values in the East.³⁰ In effect, the Eastern Wilderness Act was the first tangible step in a movement to bring more developed wilderness areas into the national system.

Every wilderness designation in the West had enveloped historic working landscapes, but the Eastern Wilderness Act and later designations drew attention to the topic by enveloping landscapes where the history of human activities was more apparent and well known. In 1978 twenty-six new wilderness areas were designated on undeveloped National Forest System lands under the Endangered American Wilderness Act. Wilderness advocates called these areas “endangered” to reflect concerns that they were overlooked, merited protection, and vulnerable to development. Many of these endangered areas were located near cities and had the potential to provide significant experiential and recreational opportunities for large populations. Ostensibly, the Forest Service had excluded these “endangered” areas from their previous wilderness inventories because the lands were too developed and more suited to serve other aspects of the agency’s mission, such as timber production. Through the act, Congress determined that impacted areas could still be designated as wilderness. In Oregon, the Endangered American Wilderness Act established the Wild Rogue and Wenaha-

³⁰ “Law Search,” Wilderness Connect.

Tucannon Wilderness and expanded the Mount Hood, Kalmiopsis, and Three Sisters wilderness areas.³¹

The National Wilderness Preservation System continued to expand and encompass relatively developed places that federal agencies had not included in their initial recommendations following the 1964 Wilderness Act. In 1984 the Oregon Wilderness Act added more acreage and more forested areas to the wilderness system than any other previous year of legislative action. It also prescribed that the land outside the boundaries of newly designated wilderness areas should open to development, including timber production, for a period of at least ten to fifteen years.³² The new additions were: Mark O. Hatfield (formerly “Columbia”), Badger Creek, Bull of the Woods, Salmon-Huckleberry, Drift Creek, Rock Creek, Cummins Creek, Boulder Creek, Rogue-Umpqua Divide, Waldo Lake, Menagerie, Middle Santiam, Grassy Knob, Red Buttes, Sky Lakes, Bridge Creek, Mill Creek, Black Canyon, North Fork John Day, North Fork Umatilla, Monument Rock, Table Rock, and Mount Thielsen wildernesses. The expanded areas were Mount Jefferson, Mount Washington, Three Sisters, Gerhart Mountain, Eagle Cap, Strawberry Mountain, Hells Canyon, and Diamond Peak wildernesses.

The Oregon Wilderness Act was prompted by the Roadless Area Review and Evaluation processes (RARE I and RARE II), which were required by the Wilderness Act as a way to identify “de facto wilderness” that should be protected in future designations.

³¹ Wilderness Connect, <https://wilderness.net>. The Wild Rogue Wilderness was the first wilderness administered by the Department of the Interior Bureau of Land Management in Oregon.

³² Wilderness Connect, <https://wilderness.net>.

The RARE process was controversial and slow-going, so by the time it ended the Forest Service was struggling to hold off timber sales in roadless areas, and accessible commercial timber stands were being over-cut.³³ The act provided relief on all sides by extending protections for some wilderness areas and “releasing” other areas for timber harvest. Congress passed similar state-wide bills around the same time, all to resolve the RARE process.

Collectively, the 1984 cohort of wilderness laws provided the largest expansion to the National Wilderness Preservation System since the Wilderness Act, and no legislation since then has added as much land in a single stroke. In Oregon, the Opal Creek Wilderness was established in 1996, and the Steens Mountain Wilderness was established in 2000. In 2009, Congress passed the Omnibus Public Land Management Act, which adds seven new designations: the Clackamas, Copper Salmon, Lower White River, Oregon Badlands, Roaring River, Soda Mountain, and Spring Basin wilderness areas. The most recent addition is the Devil’s Staircase Wilderness, established in 2019.³⁴ Advocacy groups, such as the non-profit organization Oregon Wild, continue to work on expanding the National Wilderness Preservation System to encompass more relatively undeveloped land (Figure 3.2). With each expansion, the National Wilderness Preservation System simultaneously extends protections for wilderness and envelops more historic resources.

³³ Williams, *U.S. Forest Service in the Pacific Northwest*, 293

³⁴ Wilderness Connect, <https://wilderness.net>.

Lessons

Each wilderness designation reflects a complicated, costly political process and a significant achievement won by dedicated constituents. While wilderness advocates need to recognize that protections for historic resources are in fact embedded in the Wilderness Act, historic preservationists should also take care to ensure that their actions do not play into broader political debates that could threaten wilderness protections. The work ahead will involve developing our knowledge and skills to conducting heritage work in wilderness with methods that strictly adhere to all regulations that protect wilderness.

As a final note, heritage professionals can also lend their expertise to support the wilderness movement by articulating historic contexts and engaging communities to honor the wilderness lands that they will inherit. It seems plausible that the context of wilderness management will continue to evolve and yet retain its focus on experiential values. The human side of wilderness has been its strength as well as the source of its “troubles,” as William Cronon and others have observed. Heritage professionals can help carry wilderness management into the future and empower a broader appreciation of the human experience in wilderness.

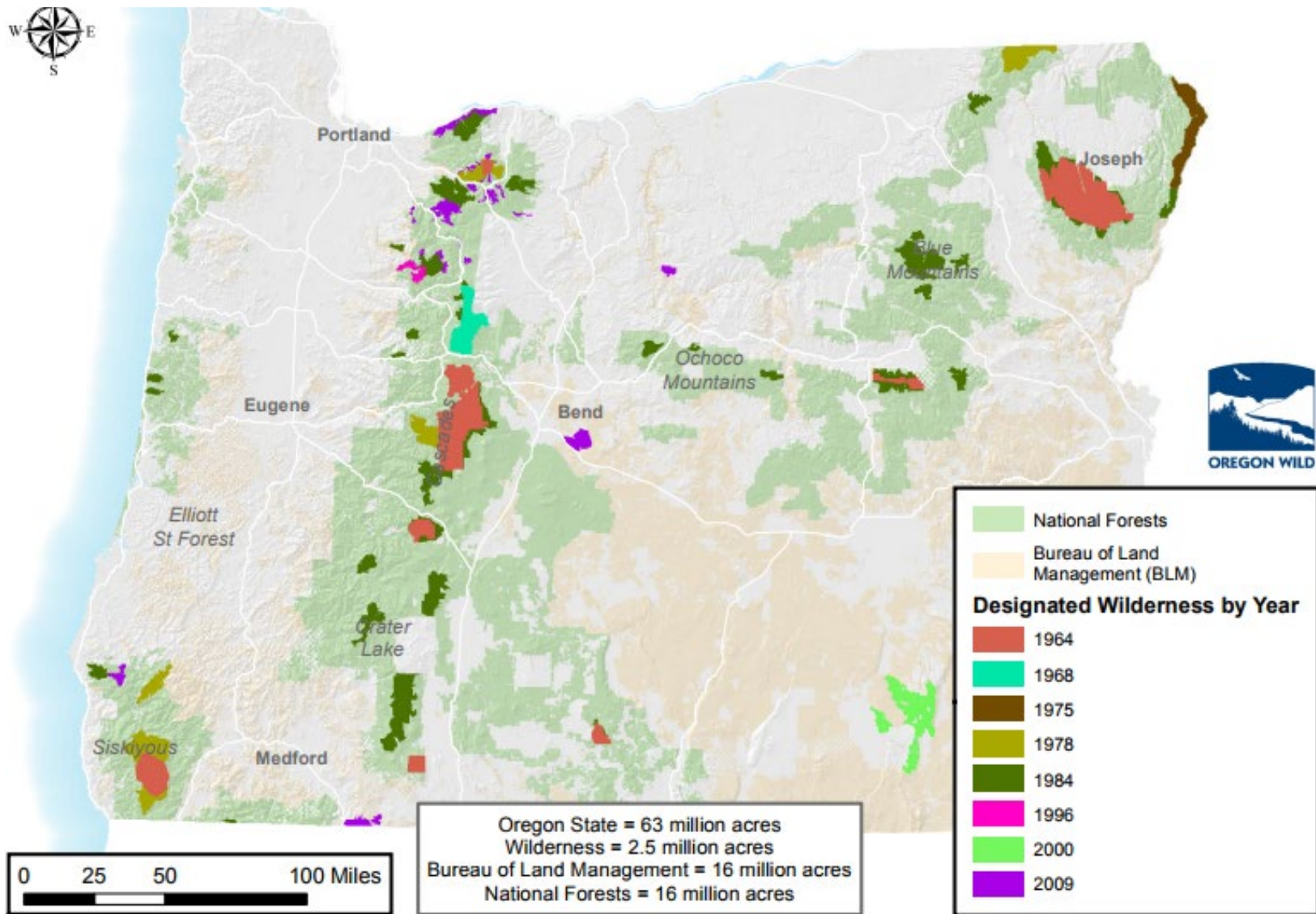

Figure 3.1. Chronological wilderness designations in Oregon (Oregon Wild, 2009).

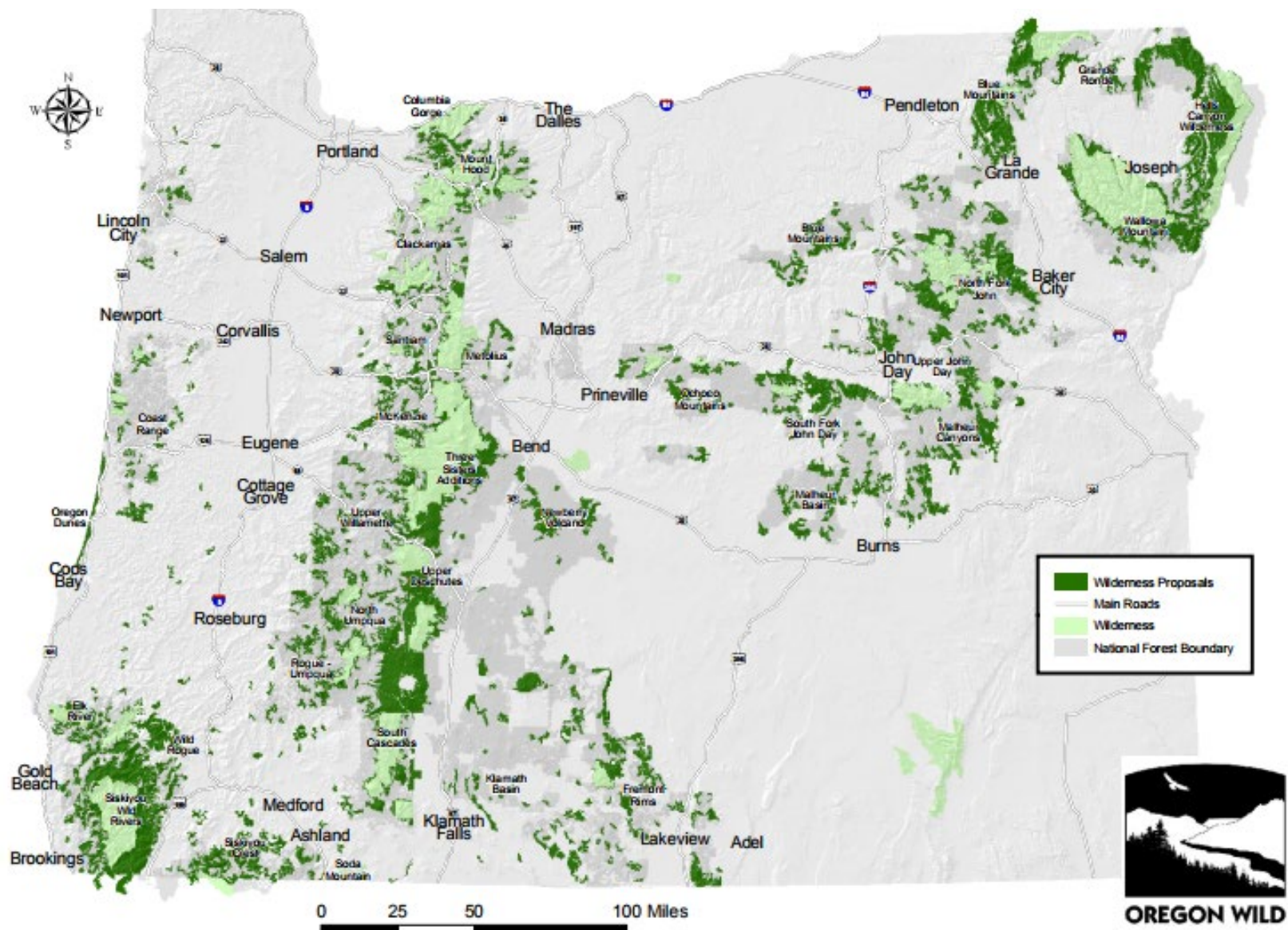

Figure 3.2. Map of proposed expansions to wilderness areas in Oregon (Oregon Wild, 2009).

CHAPTER IV

INVENTORY AND ASSESSMENT METHODS

Today, Oregon wilderness consists of forty-eight designated areas and 2.5 million acres that include approximately thirty five historic sites with buildings and structures. The research conducted for this study now provides the first quantitative analysis of historic buildings and structures in Oregon wilderness through an inventory effort that relies on existing documents, digital maps, and consultation with Forest Service staff. The inventory includes primary data about each relevant historic site. Moreover, it helps address simple research questions: (1) Which wilderness areas contain historic buildings and structures; and (2) Which architectural types and historical contexts do they represent? Properties were exclusively identified through existing documentation, rather than by a reconnaissance survey of any wilderness areas. The inventory should be improved and amended over time through further research, but in the meantime, this study provides a rare birds-eye view of historic sites in wilderness.

This study also provides a more profound qualitative look at roughly half of the sites listed on the inventory through a series of site visits and condition assessments. Site visits are an ideal way to refine the inventory. Site visits addressed research questions about buildings and structures in wilderness: (1) Has their condition been maintained; and (2) Given limited financial resources, what priorities should inform management decisions among federal agencies that are responsible for these heritage sites? Ideally, future researchers will visit all of the inventoried sites in-person to gather holistic, qualitative information and inform further preservation projects. In the meantime, these

site visits inform a discussion about management strategies and preservation priorities of the past, present, and future.

Inventory Methods

To begin the inventory effort, I contacted the State Historic Preservation Office (SHPO) to review their records of historic sites that might overlap federal wilderness. According to the National Historic Preservation Act, each SHPO works “in cooperation with Federal and State agencies, local governments, and private organizations and individuals, [to] direct and conduct a comprehensive statewide survey of historic properties and maintain inventories of such properties.”¹ In theory, the office has a unique broad-scale view of preservation efforts across many agencies and jurisdictions throughout the state. In practice, the SHPO's efforts interact with federal land on a case by case basis. Federal agencies are ultimately responsible to inventory their own properties and SHPOs do not have enforcement powers. The SHPO's records were too sparse to form a useful inventory in wilderness, so I turned to the Forest Service for more comprehensive data.²

The Forest Service maintains a database called the Natural Resource Management (NRM) system, which combines tools for managing data across all disciplines within the agency. When I inquired for a list of buildings located in wilderness, Forest Service staff at the Pacific Northwest Regional office confirmed that NRM includes data regarding the status of heritage resources, use and maintenance of facilities, and geographic boundaries

¹ National Historic Preservation Act, Ch. 3023, §3 (1966).

² The State Historic Preservation Office does house records about historic sites in wilderness but most of these records coincide with a project that required the Forest Service to follow procedures laid out in Section 106 of the National Historic Preservation Act.

of wilderness areas. However, these datasets are managed by different programs within the agency and may not seamlessly connect. Forest Service personnel recommended that I start by reviewing records from the Buildings application, which is maintained by the agency's engineers and facilities managers. I then built a project-specific geographic information system (GIS) that could identify which buildings and structures were actually in wilderness areas. The GIS combined four layers of spatial data: Oregon state boundaries, National Forest boundaries, wilderness boundaries, and building locations in Oregon and southern Washington.³

Using the Buildings application of NRM, the Pacific Northwest Regional Office provided a spreadsheet of more than 8,500 “buildings” and “features” across the national forests in Oregon and southern Washington. The initial data set included duplicate records, typos, and undefined acronyms that took some time to organize and decipher. However, it was refreshing to work with too much information rather than too little. I completed the GIS analysis by merging geospatial attributes from the wilderness, national forest, and NRM layers to create a new spreadsheet. This product looks like the previous NRM spreadsheet, but it includes additional fields that identify the national forest, forest

³ “Wilderness Data and National Wilderness Preservation System Map,” Wilderness Connect, <http://www.wilderness.net/map.cfm>. “Administrative Forest Boundaries,” U.S. Department of Agriculture, Forest Service, Geospatial Data Discovery, <http://enterprisecontent-usfs.opendata.arcgis.com>. U.S. Department of Agriculture, Forest Service, Natural Resources Manager, Infrastructure database shared via personal correspondence with Charles Ruhsenberger, Regional Facilities Program Assistant, Pacific Northwest Region in March 2016.

Wilderness spatial data came from Wilderness Connect, a collaborative project between the University of Montana's College of Forestry and Conservation Wilderness Institute, the Arthur Carhart National Wilderness Training Center, and the Aldo Leopold Wilderness Research Institute. The database compiled by these organizations helps to fulfill a federal mandate under Section 3(a)(2) of the Wilderness Act which states that The Secretary of Agriculture shall “maintain, available to the public, records pertaining to said wilderness areas.”

district, and wilderness area surrounding each facility. At this stage, the inventory consisted of roughly 100 structures.

This data was a critical tool that did not replace the expertise of Forest Service staff, but instead provided a strong premise for our conversations about buildings and features in each forest. I spoke with heritage staff on every Forest in the state and asked them to verify and correct the list. Working together, we weeded out duplicate records and consolidated records that document individual buildings within a single site or district. We also identified and removed several records that had erroneous location coordinates and were actually located outside of the wilderness boundaries. We retained buildings that had been documented before and likely still existed in some form or condition. I also consulted maps, satellite images, books, and blog posts to verify the location and general appearance of each building on the list. This level of scrutiny served as a form of “ground-truthing,” since it was not immediately feasible to visit each site in person.

As we worked together to refine and synthesize information gleaned from the GIS, the inventory shrank from 100 records to thirty-five (Figure 4.1). The completed inventory has thirty-five sites that each include at least one extant building or structure that is eligible for the National Register of Historic Places or has not yet been evaluated but may be eligible. Some complex sites, such as the group of cabins, sheds, and barns at Red's Horse Ranch, are grouped under a single name in the inventory.

It is likely that some historic resources have been overlooked. Nonetheless, the inventory provides an unprecedented baseline that future researchers can reference and

refine. I am confident that the inventory includes most of the historic building and structures that retain their condition and integrity in Oregon's wilderness. By that standard, all of these resources may benefit from future preservation work, including research, documentation, evaluation, maintenance, or restoration.

Condition Assessments

With the inventory in hand, I was finally able to visit multiple historic sites to find out more about how they are currently used and maintained (Figure 4.2). The Forest Service's Pacific Northwest Regional office offered to fund a series of assessments, so we engaged HistoriCorps, a nonprofit preservation organization, to administer the grant under an existing partnership agreement.⁴ During the summer of 2017, I hiked more than one hundred miles and assessed fifteen historic sites in three national forests and seven wilderness areas throughout Oregon. As the Principal Investigator, I coordinated the resources provided by HistoriCorps and the Forest Service, completed assessments, and wrote reports. Forest Service staff at the regional office and the forest districts shared guidance and information about how to access each site. HistoriCorps staff recruited volunteers, provided technical advice, and edited the final report. In the end, the partners produced a report entitled *Historic Structures in Oregon Wilderness*, which provided recommendations about conditions and preservation treatments for fifteen of the thirty-

⁴ By 2017, HistoriCorps had completed numerous preservation projects on Forest Service land throughout the country. A partnership with the Forest Service was well established, in both an operation and cultural sense. This project was undertaken through a Supplemental Project Agreement in association with Master Participating Agreement #13-PA-11132424-409 between HistoriCorps and the USDA Forest Service.

five historic sites included in the inventory (Appendix D). The study was collaborative and efficient, and it had no adverse effect on wilderness.⁵

Working with the Forest Service and HistoriCorps, I created a travel circuit and assessment schedule to reach as many sites as possible on each trip. We prioritized as follows: (1) locations where it was possible to assess multiple sites on a single trip, (2) sites which heritage staff requested to prioritize, and (3) sites that would demonstrate a range of building types, uses, and conditions. Fieldwork took place from early July to early September 2017.

In the end, I assessed fifteen sites in seven wilderness areas on three National Forests:

- Rebel Rock, Olallie Mountain, and Waldo Mountain lookouts in the Three Sisters Wilderness, Willamette National Forest;
- Timberline Trail shelters at Elk Meadow, Cairn Basin, McNeil Point, Cooper Spur, and Gnarl Ridge as well as the Upper Sandy Guard Station in the Mount Hood Wilderness, Mount Hood National Forest;
- Devil's Peak Lookout in the Salmon-Huckleberry Wilderness, Mount Hood National Forest;
- Bull of the Woods Lookout in the Bull of the Woods Wilderness, Mount Hood National Forest;
- Kinzel Mining Cabin in the Badger Creek Wilderness, Mount Hood National Forest; and

⁵ In current theory and practice, actions undertaken in wilderness have a positive, neutral, or negative impact on the qualities of wilderness character. This echoes language used throughout other forms of environmental compliance work, such as Environmental Assessments required by the National Environmental Policy Act of 1969, or assessments of effect required by Section 106 of the National Historic Preservation Act.

- Mule Peak Lookout, Millard Guard Station, and Red’s Horse Ranch in the Eagle Cap Wilderness, Wallowa-Whitman National Forest.

We had hoped to reach additional sites, such as Skyline Trail shelters on the Willamette National Forest and Muskrat Cabin on the Deschutes National Forest, but dynamic factors cut-off access to several sites during the narrow windows of opportunity when we might have reached them for an assessment (Figure 4.3).⁶

Before this work began, the partners used the Minimum Requirements Decision Guide (MRDG or Decision Guide) to guide research methods and identify potential effects to wilderness character (Appendix A). The Decision Guide is a tool that was developed by the Arthur Carhart Wilderness Training Center and has been implemented by all four federal agencies that manage wilderness. It is designed to preempt more intensive compliance documents by evaluating proposed projects to determine if the proposed actions are necessary, better than inaction, and can be revised to minimize any adverse effect to wilderness character. The Decision Guide assumes a level of familiarity and fluency with the Wilderness Act of 1966, as well as other relevant legislation and agency-specific policies. It asks a series of questions that reinforce the preeminence of wilderness above all other concerns.

Step 1 of the process emphasizes the importance of conducting work only when a federal agency is required to do so.⁷ In this case, we cited the National Historic

⁶ Our obstacles included wildfires, closed and washed-out roads, hazardous air pollution, a lightning storm, and even a highly anticipated solar eclipse that drew crowds to the Mount Hood National Forest and prompted the Forest Service to prohibit backcountry work for about one week.

⁷ Specifically, the Decision Guide’s Criteria for Determining Necessity are: (A) Is action necessary to satisfy valid existing rights or a special provision in wilderness legislation (the Wilderness Act of 1964 or subsequent wilderness laws) that requires action? (B) Is action necessary to meet the requirements of other federal laws? (C) Is action necessary to preserve one or more of the five qualities of wilderness character?

Preservation Act (federal law) and Forest Service Manual (agency policy) to affirm that assessing these historic sites serves the agency's mandates and mission. This project would help the agency comply with the National Historic Preservation Act by offering recommendations regarding the condition, integrity, and eligibility of historic sites. It would also help preserve the fifth quality of wilderness character, "other features of value," which includes historical resources.⁸

Step 2 of the process emphasizes the importance of conducting necessary work in a manner that has a minimal impact on protected wilderness characteristics. In this case, we affirmed that we would work in small groups, spend less than one week in each wilderness area, use existing trails, travel on foot (although horseback would also have been allowed in most cases), and follow "Leave No Trace" principles (Figures 4.4 and 4.5). Our methods involved no motorized equipment, mechanical transport, or other uses prohibited by Section 4(c) of the Wilderness Act. We even enclosed a list of tools and equipment to make sure that all items were appropriate in wilderness (Figure 4.6).

The Decision Guide process evaluates potential projects by assigning a value of -1, 0, or 1 to describe the anticipated impact that each action will have on each quality of wilderness character. In our application of the Decision Guide, Forest Service staff concluded that the proposed assessment work would not affect the "untrammelled," "undeveloped," or "natural" qualities of wilderness. The fourth quality, "opportunities for solitude or primitive and unconfined recreation," might be adversely affected by our

⁸ In reference to the fifth quality of wilderness character, Forest Service personnel wrote, "Whether and how these historic structures contribute to wilderness character for the respective wilderness areas in which they are located has not yet been formally evaluated through wilderness character narrative or other process. Information gathered through cultural resource assessment surveys could help to inform future evaluation and any appropriate protection measures."

work at each historic site, but only for the duration of our fieldwork.⁹ The fifth characteristic, “other features of value,” includes cultural resources and would, therefore, be positively affected by our work. The negative impact on solitude negates the positive effect on cultural resources. A score of 0 indicates no accumulative impact on wilderness character.

It is worthwhile to note that if our work did not impact the fourth quality of wilderness character this project would have had a net-positive impact on wilderness character. In this case, the Region’s wilderness staff determined that trips to and from each site would not adversely affect another party’s experience because we would be indistinguishable from a typical hiking group (Figure 4.4). The adverse effects would only occur when and if another party briefly encountered the assessment team at work. The Region’s wilderness staff made this determination based on their expertise in applying the Decision Guide and managing wilderness in order to protect its wilderness character. I will not rush to contradict them in this matter, but this topic may merit further consideration.

To conclude the Decision Guide process, resource managers end their analysis by considering whether inaction, as an alternative to the proposed action, might have a more significant positive impact on wilderness character. In this case, inaction would have no effect on the first four qualities but would harm cultural resources included in “other

⁹ In reference to the fourth quality of wilderness character, Forest Service personnel wrote, “Wilderness visitors may encounter personnel traveling to and from the site on trails and camping in the vicinity of the site. Wilderness visitors may encounter personnel conducting cultural resource condition assessments of historic structures, may see personnel visible at historic structures, and/or may hear human voices as personnel conduct assessments.”

features of value.”¹⁰ Therefore, the negative impact on cultural resources gives the “no action alternative” an accumulative score of -1.

As the fieldwork progressed, we were able to uphold the research design, as stated in the Decision Guide. At each site, I followed a replicable protocol to evaluate and document the existing conditions of each building or structure, beginning with the exterior at ground-level and progressing to the interior (Appendix B). I gradually reduced my toolkit until all essential items fit in one small daypack. At a minimum, sites required a smartphone or camera, tape measure, pen, and a pocket notebook (Appendix C). Wilderness restrictions did not prevent, impede, or alter the methods that I typically use to conduct condition assessments of small buildings and structures.

Similarly, I produced a set of condition assessment reports that follow standard preservation practice. Each report accomplished the same goals: (1) systematically document, evaluate, and explain the resource's existing conditions; (2) provide a brief field-based assessment of physical integrity and eligibility for the National Register of Historic Places; (3) provide treatment recommendations in compliance with the Secretary of the Interior's Standards for Preservation of Historic Properties; and (4) summarize and prioritize discrete tasks. To account for the wilderness setting, I included detailed information about access to each site.

¹⁰ In reference to the no-action alternative, Forest Service personnel wrote, “Managers would not have information on current conditions of historic structures to implement appropriate protective measures. Information from assessments would not be available to support development of the wilderness character narrative and identification in the narrative of which, if any, historic structures constitute other features of value for wilderness character.”

In the process of writing these assessments, I did not have to exclude any preferred recommendations because they would have been prohibited in wilderness. The Forest Service and its partners could accomplish each recommended treatment with appropriate tools. It is a matter of allocating time and skilled labor to the work. These projects could involve pack support, hand tools, traditional building technologies. Successive projects to maintain or restore these historic sites will require a new minimum requirements analysis based on the scope of work and methods involved.

In conclusion, this research demonstrates that condition assessment methods are feasible and appropriate in wilderness. Site visits and assessments help wilderness stewards manage the fifth quality of wilderness character, which includes historic resources, and they simultaneously help heritage stewards manage historic sites that are protected by federal law and agency policies. Assessments cause no accumulative effect to wilderness character and require no prohibited actions. Within that context, this thesis makes a significant contribution to the Forest Service's heritage and wilderness programs by addressing fifteen sites from the inventory of thirty-five historic sites. Ideally, future researchers will complete condition assessments of all other sites included in the inventory.

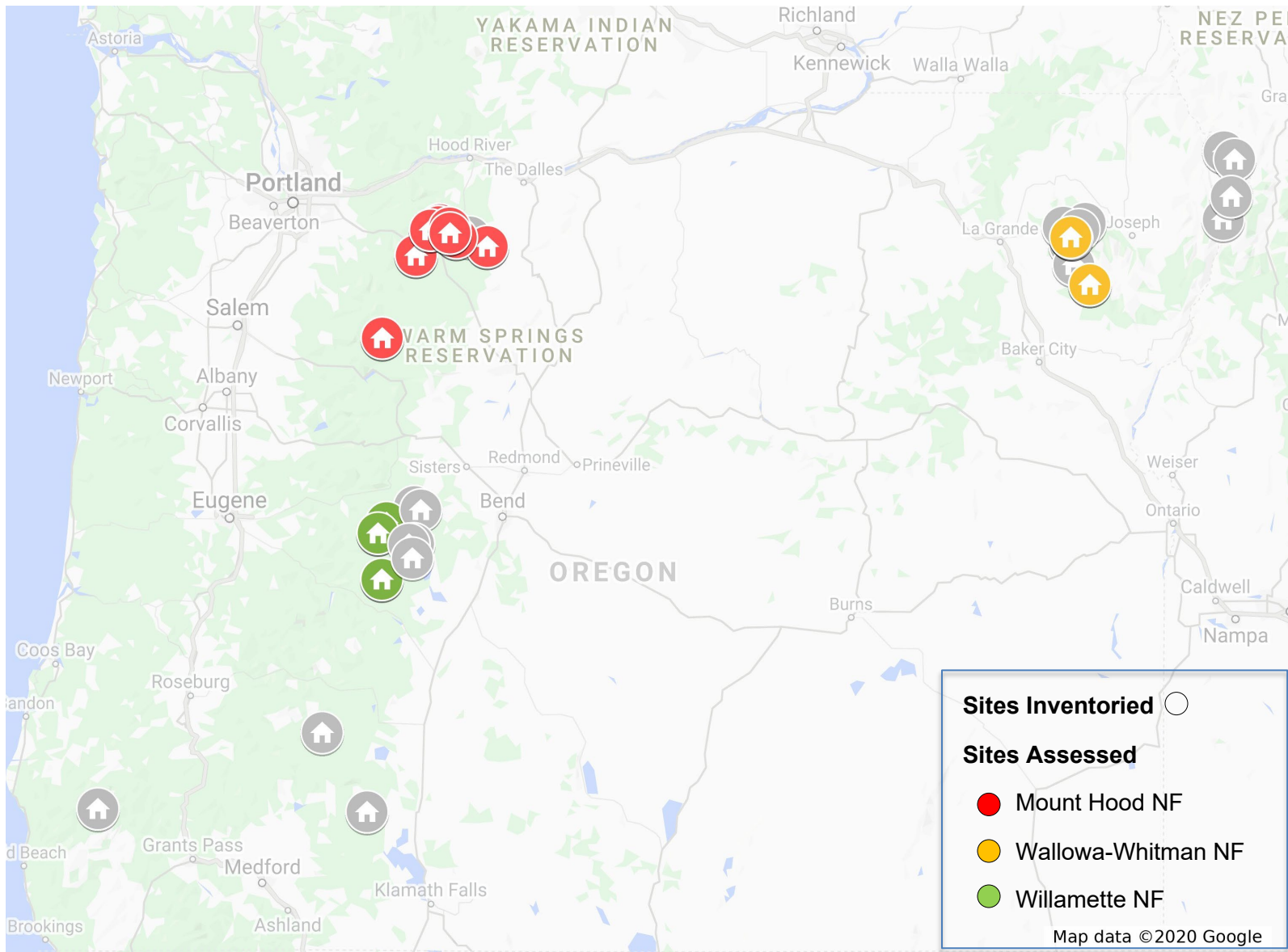

Figure 4.1. Historic sites inventoried and assessed during this study.

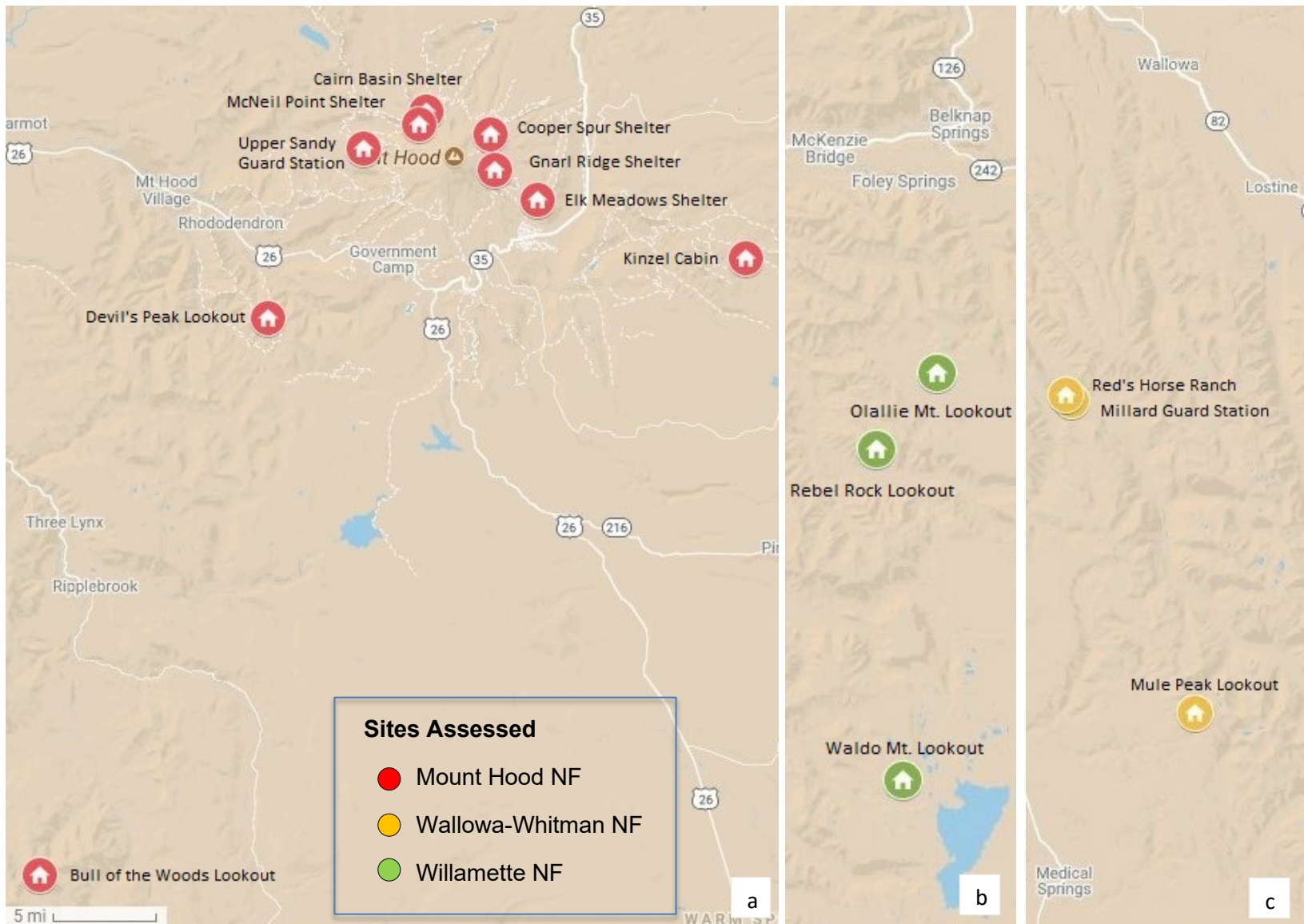

Figure 4.2. Sites assessed on the (a) Mount Hood, (b) Willamette, and (c) Wallowa-Whitman National Forests in this study.



Figure 4.3. Visitors gathered at Bull of the Woods Peak in the Bull of the Woods Wilderness to view a solar eclipse from the path of totality in July 2017.



Figure 4.4. Relative impact of a six-person crew hiking to assess the Upper Sandy Guard Station in the Mount Hood Wilderness, Mount Hood National Forest. Photo by Dan Everhart, Restore Oregon, July 2017.



Figure 4.5. Relative impact a single person traveling in wilderness to assess historic sites including: (a) encampment at Elk Meadow Shelter in the Mount Hood Wilderness, Mount Hood National Forest; and (b) hiking to Mule Peak Lookout in the Eagle Cap Wilderness, Wallowa-Whitman National Forest in July 2017.



Figure 4.6. Volunteers use tools to investigate and record conditions at historic sites in wilderness during the course of this study: (a) John Milliken and the author use tools to measure and record conditions at McNeil Point Shelter (Jonas Landes, 2017); (b) Milliken engineers a device to inspect the roof of Waldo Mountain Lookout; (c) Dan Everhart of Restore Oregon uses a hand rake to inspect sill logs at the Upper Sandy Guard Station; and (d) John Helmer uses a headlamp to investigate floor joists at the Millard Ranger Station.

CHAPTER V

ARE PRESERVATION PROGRAMS EFFECTIVE IN WILDERNESS?

The inventory of thirty-five historic sites and the findings of fifteen condition assessment reports are summarized here with a series of tables to help draw out correlations and commonalities and address the research questions that prompted this effort. The four research questions are: (1) Which wilderness areas contain historic buildings and structures? (2) What architectural types and historical contexts do they represent? (3) Has their condition been maintained? (4) Given limited financial resources, what priorities should inform management decisions among federal agencies that are responsible for these heritage sites?

This first table, Inventory of Historic Sites in Oregon Wilderness, lists sites by name, location, historic status, date of construction, building type, primary material, use, and condition (Table 5.1). In this table, “NRHP Listed” is a binary category which indicates that each site is either listed, or not listed, to the National Register of Historic Places.¹ “Construction Date,” “Building Type,” and “Original Use” are straightforward. “Primary Material” (meaning building material) is informed by photographs published online via blog posts and trail reports as much as by Forest Service records. “Administrative Use” and “Evident Use” are both interesting, albeit subjective, categories that I include to convey how the Forest Service and the public appear to interact with these sites. Finally, the overall physical condition of each site assessed is summarized in the right-hand column, “Condition.” This table summarizes the entire inventory of

¹ The Forest Service and other federal agencies treat eligible sites as if they are listed in the National Register, as is required by the National Historic Preservation Act. However, the agency also aspires to list eligible properties.

historic sites in Oregon wilderness as reported through my consultations with Forest Service staff and the agency's NRM database.

There is room to improve this inventory. The information is a baseline summary that draws on available records (Table 5.2). Information about historical uses, current uses, NRHP status, and dates of construction are best estimates. Most determinations of eligibility are out-of-date and may not reflect current conditions at the sites. Some properties represented on the list may be ineligible for the National Register of Historic Places if they have lost physical integrity through damage or alteration. Site visits were helpful in this regard because they often revealed that conditions on the ground were at odds with older documents.

The inventory and accompanying tables provide many opportunities for further research. This inventory is limited to buildings and structures that the Forest Service has already recorded. It excludes all other resources types, such as roads, trails, walls, fences, and signs. It excludes archeological sites. Nonetheless, it provides a baseline reference that previously did not exist and succeeds in directing attention towards preservation opportunities in Forest Service wilderness areas throughout the state.

Which Wilderness Areas Contain Historic Buildings and Structures?

The Forest Service manages historic builds and structures in ten of the forty-one wilderness areas within their jurisdiction in Oregon. The Mount Hood, Wallowa-Whitman, and Willamette National Forests bear the greatest responsibility for managing historic buildings in wilderness. The Rogue-River Siskiyou, Umpqua, and Deschutes

National Forests each have just a few sites. Other forests in the state reported no historic buildings or structures in wilderness.

The Eagle Cap Wilderness dominates this inventory with eight recorded sites, including several ranching properties that include multiple structures. The Three Sisters Wilderness contains seven sites (trail shelters and fire lookouts) all associated with the Forest Service’s administrative programs. The Mount Hood Wilderness holds third place with six recorded sites (trail shelters and a guard station), all historically associated with the Forest Service’s administrative programs and specifically the Timberline Trail. The Hells Canyon Wilderness includes three sites. The Badger Creek Wilderness includes two sites. The Bull of the Woods, Rogue-Umpqua Divide, Salmon-Huckleberry, Sky Lakes, Waldo Lake, and Wild Rogue wilderness areas each contain one historic administrative structure.

Most documented sites, buildings, and structures in wilderness are located in the Cascade Range, Wallowa Mountains, and Hells Canyon. This pattern correlates with the pattern of distribution for wilderness areas across the state: the oldest and largest designations are in these same regions of Oregon. Within each wilderness area, the assessed buildings and structures are all situated on established trails. On average, they are within two aerial miles of the wilderness boundary and four trail-miles of a trailhead sited outside wilderness.

What Building Types Are Represented?

The table called “Building Types and Conditions” elaborates on the fifteen sites assessed in 2017 (Table 5.3). This table groups the sites into four classes: fire lookouts,

trail shelters, guard stations, and cabins. It summarizes building types, materials, and conditions to help identify certain building types and materials that might be relatively easy or difficult to maintain in wilderness. These categories are loosely defined.

The properties in this inventory are eligible for the National Register of Historic Places under Criterion A, Criterion C, or both. In the National Register, sites are eligible under Criterion A for their associations with events that have made a significant contribution to the broad patterns of our history. Sites are eligible under Criterion C for their value in embodying the distinctive characteristics of a type, period, or method of construction. In this study, I did not encounter any buildings or structures in Oregon wilderness that have a recognized significance under Criterion B, for their associations with individuals, or Criterion D, for their potential to yield information (most often archeological) important to prehistory or history.

The inventory shows that most extant historic buildings and structures in Oregon wilderness were built by the Forest Service to serve administrative functions. To a lesser extent, private entities historically developed these sites for ranching, trapping, commercial recreation, and mining. All functional types found in wilderness areas indicate dispersed uses, rather than uses that would be more common in population centers. Some of the inventoried sites originally served domestic purposes. They housed people who were involved in private enterprises, such as ranching and mining, or resource protection through the Forest Service. The inventory includes three ranches, and each includes barns, sheds, and other buildings originally built for agricultural purposes. Forest Service administrative sites were built to monitor and protect natural resources,

house the agency's staff, and facilitate public recreation. They include trail shelters, fire lookouts, patrol cabins, and guard stations.

Most of the historic buildings and structures in this inventory have been repurposed for new uses or have no use at all. Some administrative buildings are still in use by the Forest Service. Others have recreational use, both unofficially and through sanctioned Forest Service programs. Trail shelters that are intact have retained their original use. I did not find any examples of a trail shelter adapted for a new use. Domestic use has declined substantially across these properties. In part, this may reflect that people now prefer tent camping for recreation and administrative purposes on the National Forests. Ranching, resource extraction, and agricultural uses have also declined, because they are now excluded activities within wilderness areas. The cabins, sheds, and other auxiliary structures that were historically associated with these enterprises are, in some cases, repurposed as tool sheds and emergency shelters.

On the topic of original versus adaptive uses, Red's Horse Ranch is a noteworthy exception compared to other buildings and structures in wilderness. It is a historic district comprised of multiple buildings and documented landscape features. Private owners originally developed the property as a ranch ca. 1910 and then expanded operations immediately after World War II to offer guest accommodations and guide services. The Forest Service acquired the ranch in 1994 as an extension to the Eagle Cap Wilderness. The agency allows several traditional uses to continue. There is an active volunteer caretaker program that maintains a barn, a ranch house, and several cabins to

accommodate the caretakers, their horses, and their interactions with public visitors. The caretakers also maintain a small historic airstrip to fly in people and supplies.²

I did not find any examples of cabins in wilderness areas that have been substantially repurposed for a new use, which is noteworthy because this is a growing practice on the national forests nationwide. For instance, the agency has preserved historic patrol cabins, fire lookout towers, and other buildings by adding them to the “recreation rental” program. Thus far, this practice excludes historic sites in Oregon wilderness areas.

Regarding style and materials, most of the inventoried sites do not include high style buildings that illustrate refined architectural and artistic movements. Instead, they are vernacular buildings that demonstrate technological developments and common construction techniques true to their time. Wood is the most prominent construction material, by far. Most buildings are of log, plank, or stud-frame construction. Metal, glass, stone, and synthetics (such as fiberglass, vinyl, rubber, and plastic) are used to a lesser degree. None of the structures use earth, stucco, brick, terra cotta, asphalt, adobe, ceramics, or cloth in any significant way.

On the topic of style and materials, Waldo Mountain Lookout demonstrates distinctly modern aesthetics and prefabricated materials, including plywood, linoleum, and a flat roof sheathed in synthetic materials. Some of the late additions at Red’s Horse Ranch also use engineered plastics, plywood or particleboard, and chain-sawn log-work. Other buildings and structures in this inventory express the Rustic style. For instance, the

² The airstrip is now maintained with a horse team or mule team, rather than through mechanized means.

Upper Sandy Guard Station is an exceptional design that includes well-crafted battered log walls, a massive free-standing chimney, and elaborate ironwork. The Timberline Trail's stone shelters also express an intentional Rustic design.

Have Conditions Been Maintained Since the Wilderness Designation?

The table titled "Use and Conditions" explores how the occupation or use of a historic building may relate to its condition (Table 5.4). From what I have seen, there are no maintenance issues specific to the wilderness setting – although vandalism, neglect, and severe weather are common factors. The resources included in this study exhibit a range of conditions that the Forest Service and its partners could address with a variety of treatments (tasks). Five of the sites are in poor condition, six are in fair condition, and four are in good condition. Most required simple repairs that would fall into the category of routine maintenance, but several sites would benefit from more substantial preservation work to address the poor condition of foundations, floors, walls, windows, roofs, and other architectural systems. These sites reflect a mix of professional and improvised maintenance measures.

"Professional maintenance" here means that treatments and interventions follow a professional protocol entitled the *Secretary of the Interior's Standards and Guidelines for the Treatment of Historic Properties*. The Secretary's Standards protect a property's integrity. Properties that retain their integrity can physically and aesthetically reflect their historical associations and they are eligible for the National Register. Integrity and condition are closely related, but only because they directly address the physical state of any historic property.

Administrative use is the most significant factor that correlates with professional maintenance and good condition. Historic sites and structures that are actively used for administrative purposes and appropriately maintained are typically in good condition. The conditions of Millard Ranger Station and Waldo Mountain Lookout exemplify these proactive preservation strategies (Figure 5.1). They are occupied and maintained in a way that protects their historical integrity.

This table further shows that historic buildings that have mixed administrative and public use also demonstrate a mix of professional and improvised maintenance. These buildings are typically in fair condition. Devil’s Peak Lookout exemplifies this category, but Bull of the Woods Lookout and several Timberline Trail shelters have similar dynamics (Figure 5.2).

Vacant buildings typically have little-to-no maintenance and are in poor or critical condition. The Upper Sandy Guard Station and Olallie Mountain Lookout exemplify this category (Figure 5.3). They are unoccupied, in poor condition, and were briefly stabilized with short-term measures such as a tarp secured over the guard station roof and 2x4 braces installed inside the lookout. Gnarl Ridge Shelter, Kinzle Cabin, and Rebel Rock Lookout reside at the bottom of this table, fully in the category of “no maintenance (neglect).” The shelter and the cabin were ruins when I saw them in 2017, and the lookout was a brittle, vandalized mess that burned in the Rebel Fire just a few weeks after our site visit.

In some cases, Oregon wilderness may contain exceptional examples of common architectural types. Millard Ranger Station is a particularly fine example of a design that

the Forest Service repeatedly used when constructing early backcountry ranger stations. As of 2017, the building was in excellent condition, and almost every intervention complies with the Secretary's Standards. The Forest Service and its partners added metal security gates over the door and windows, but these facilitate the cabin's ongoing use and are reversible. The Forest Service and its partners could keep up existing conditions at this site with relatively little investment, sustaining the good work done by previous resource stewards.

In other cases, Oregon's wilderness areas may contain fragile examples of rare or remarkable architectural types. For instance, Olallie Mountain Lookout is a rather unusual example of an early front-gable variation of the L-4 lookout type. As of 2017, the building was in critical condition and could collapse at any time. Its condition is poor, but nonetheless, the near-ruined lookout retains its historical integrity. Meanwhile, Mule Peak Lookout is a C4 lookout type common to other regions but rare to the Pacific Northwest. As of 2017, the building was well-maintained and actively staffed with volunteer fire lookouts. The lookout is in good condition, but past repairs also removed historic fabric and added new anachronistic features that mar the building's integrity. Thus, these two fire lookouts have been neglected in different ways. The Forest Service and its partners could conduct substantial work and improve both sites. But where should they start?

What Priorities Should Inform Management Decisions?

To that end, the final table titled "Preservation Conditions and Opportunities" describes fifteen sites by name, physical condition, urgency of recommended treatments,

and physical integrity (Table 5.6).³ It helps pivot away from the misperception that it might be inappropriate to preserve buildings in wilderness, and refocuses our energy on implementing proactive preservation strategies. The Forest Service and its partners could work on maintaining all of these properties in good condition. They could improve the sites' integrity and also provide a safe environment for Forest Service staff or the public to interact with these sites. I propose that a simple evaluation can reliably identify potential opportunities to take action and improve the condition and integrity of historic structures.

In this evaluation, physical condition is “good, fair, or poor,” the urgency of recommended treatments is “high, medium, or low,” and physical integrity is “high, medium, or low.” This table gives each site an “opportunity score” calculated by assigning a value of one, two, or four to each characteristic. Four is preferred, two is less preferred, and one is the least preferred. Preserving historic sites that are already in “good” condition is preferred because they mostly require cyclical maintenance and may not require more substantial restoration. Tasks that have “high” urgency are preferred because this indicates an opportunity to intervene by tackling critical tasks before the structure's condition degrades. “High” integrity is preferred because original features can be maintained rather than reconstructed.

³ The evaluation categories and scoring system come from an earlier evaluative method, which I developed initially while writing “Historic Structures in Oregon Wilderness” for the Forest Service in 2017. The new version, published here, lends more weight to historical integrity and conditions and lends less concern for access or historical significance. The previous version included values of -1, 0, and 1 as well as additional categories of “access” and “rarity.” I have removed “access” because all these resources are located within a day's hike from a trailhead. I have removed “rarity” because it is not a valued attribute in the National Register. With fewer categories involved, I have adjusted the scoring system to provide a more useful distribution of points.

In this case, the evaluation indicates that Waldo Mountain Lookout in the Waldo Lake Wilderness offers the greatest preservation opportunity, with a score of 12 (Figure 5.4). The building is in good condition and has high integrity, but also needs urgent work. As of 2017, a large section of rolled roofing material had blown off and left the roof deck exposed to rain and snow. In this situation, the Forest Service and its partners can protect a site that embodies decades of consistent and effective investment.

The next-best preservation opportunity is McNeil Point Shelter in the Mount Hood Wilderness, with a score of 10 (Figure 5.5). Like Waldo Mountain Lookout, the shelter retains its integrity and needs urgent work. Unlike the lookout, this trail shelter's condition is only fair, and it will require more work to address the underlying issues. As of 2017, the shelter's roof was in poor condition, but the stone walls were also cracked and severely undermined by erosion. The Forest Service and its partners could stymie erosion issues by repairing the roof, but the cracked walls and eroded footing would still need to be addressed.

Millard Ranger Station, Olallie Mountain Lookout, and the Upper Sandy Guard Station are in third place, each with a score of 9 (Figure 5.6). The ranger station is in good condition, has good integrity, and does not need any urgent maintenance tasks (as of 2017). Olallie Mountain Lookout and the Upper Sandy Guard Station both retain their historical integrity, and have urgent needs, but are in poor condition.

Bull of the Woods Lookout, Devil's Peak Lookout, Elk Meadow Shelter, and Red's Horse Ranch are in the next place with respective scores of 8. They all retain a high degree of historical integrity. They are in fair condition and suffer from deferred

maintenance, but none of the tasks are urgent. It is worthwhile to note that this summary, “poor condition,” is essentially insufficient for Red’s Horse Ranch because the property includes dozens of buildings in varying conditions and some are of primary significance while others are contributing resources.

Cooper Spur and Cairn Basin Shelters are in the next place with scores of 7 and 6, respectively. These shelters are both altered, but not severely. Their integrity is “medium.” Cooper Spur is in good condition, and its tasks are not urgent. Cairn Basin is in fair condition, but its tasks are moderately urgent. Together, these two shelters provide a useful example to illustrate how I think the Forest Service and its partners should direct their efforts. Cooper Spur Shelter provides a marginally better opportunity than Cairn Basin because it is already in “good” condition. The scoring system favors good conditions because the Forest Service and its partners should value and sustain the places where their preservation programs already succeed.

This evaluative method is intended to integrate preservation theory with practical concerns about limited economic resources. Accordingly, the table provides a bird-eye view of historic sites in Oregon wilderness and emphasizes opportunities for the Forest Service to preserve its heritage resources effectively. While it is a tool that can inform management decisions, the score should not be mistaken as a conclusive determination or potential “decision document.” I encourage resource managers to think about these places in complex terms and to pursue creative preservation strategies. Each project will ultimately involve a thoughtful, thorough process to consider various methods and analyze potential effects.

The Forest Service suffers from severe financial and staffing shortages, but even so, the agency and its partners should aspire to lead robust programs to protect historic resources within their jurisdictions. Every federal agency shares the same responsibilities for documenting, assessing, monitoring, and maintaining historic properties and must balance that responsibility with limited budgets and competing priorities. Many of those agencies have their own significant challenges that they overcome as they work to meet those goals. Historic buildings in wilderness do pose a challenge because they are remote, but they are also remarkably easy to maintain in contrast to large, occupied, urban buildings that other federal agencies more typically maintain.

As we tackle these projects, we will also need to work on improving collaborative relationships among the people who champion wilderness and the people who champion historic preservation. That kind of coalition-building thrives on trust and gains momentum through small successful projects. Throughout this work, I assert that typical heritage preservation strategies are appropriate and effective when applied in wilderness. I also argue that we can separate the technical and cultural challenges of working in wilderness. By focusing on “preservation opportunities” described above, the Forest Service and its partners could build their skill and capacity on the technical side while also, hopefully, building respect and collaboration on the cultural side.

Table 5.1. Inventory of Historic Buildings in Oregon Wilderness

RESOURCE NAME	FOREST	WILDERNESS	NRHP LISTED	DATE	TYPE	PRIMARY MATERIAL	ORIGINAL USE	EVIDENT USE	CONDITION
Buck Meadow Shelter	Willamette	Three Sisters	No	ca. 1930	Trail Shelter	Log	Recreation	None	Ruin
Bull of The Woods Lookout	Mount Hood	Bull of the Woods	No	1942	Lookout	Board	Gov/Admin	Admin/ Public	Fair
Bear Creek Guard Station	W-Whitman	Eagle Cap	No	ca. 1930	Cabin	Log	Gov/Admin	Unknown	Unknown
Boulder Creek Cabin	W-Whitman	Eagle Cap	No	Unknown	Cabin	Log	Unknown	Unknown	Ruin
Brushy Bar Guard Station	R-R Siskiyou	Wild Rogue	No	ca. 1933	Guard Station	Unknown	Gov/Admin	Admin	Good
Cairn Basin Shelter	Mount Hood	Mount Hood	Yes	1934	Trail Shelter	Stone	Recreation	Public	Fair
Catherine Creek Cabin	W-Whitman	Eagle Cap	No	ca. 1950	Cabin	Log	Unknown	Unknown	Unknown
Cliff Lake Shelter	Willamette	Three Sisters	No	ca. 1930	Trail Shelter	Log	Recreation	Unknown	Unknown
Cooper Spur Shelter	Mount Hood	Mount Hood	Yes	1934	Trail Shelter	Stone	Recreation	Public	Good
Cripple Camp Shelter	Umpqua	Rogue-Umpqua Divide	No	ca. 1935	Trail Shelter	Log	Recreation	None	Unknown
Deep Creek Crew Quarters	W-Whitman	Hells Canyon	No	ca. 1950	Ranch	Unknown	Agriculture	None	Unknown
Devil's Peak Lookout	Mount Hood	Salmon-Huckleberry	Yes	1933	Lookout	Board	Gov/Admin	Public	Fair
Elk Meadows Shelter	Mount Hood	Mount Hood	Yes	1934	Trail Shelter	Log	Recreation	Public	Fair
Gnarl Ridge Shelter	Mount Hood	Mount Hood	Yes	1934	Trail Shelter	Stone	Recreation	None	Ruin
High Prairie Cabin	Mount Hood	Badger Creek	No	1907	Cabin	Log	Gov/Admin	None	Ruin
Honeymoon Creek Cabin	R-R Siskiyou	Sky Lakes	No	1943	Guard Station	Log	Gov/Admin	Admin	Good

Table 5.1. Inventory of Historic Buildings in Oregon Wilderness (continued)

RESOURCE NAME	FOREST	WILDERNESS	NRHP LISTED	DATE	TYPE	PRIMARY MATERIAL	ORIGINAL USE	EVIDENT USE	CONDITION
James Creek Shelter	Willamette	Three Sisters	No	ca. 1930	Trail Shelter	Log	Recreation	None	Ruin
Kinzel Cabin	Mount Hood	Badger Creek	No	ca. 1960	Cabin	Log	Extraction	None	Ruin
Little Minam Ranch	W-Whitman	Eagle Cap	No	ca. 1950	Ranch	Unknown	Agriculture	None	Ruin
McNeil Point Shelter	Mount Hood	Mount Hood	Yes	1934	Trail Shelter	Stone	Recreation	Public	Fair
Millard Ranger Station	W-Whitman	Eagle Cap	No	ca. 1920	Guard Station	Log	Gov/Admin	Admin	Good
Mink Lake Shelter	Willamette	Three Sisters	No	ca. 1930	Trail Shelter	Log	Recreation	Unknown	Unknown
Mule Peak Lookout	W-Whitman	Eagle Cap	No	ca. 1940	Fire Lookout	Board	Gov/Admin	Admin	Good
Muskrat Cabin	Deschutes	Three Sisters	No	c. 1950	Cabin	Log	Trapping	None	Ruin
Olallie Mountain Lookout	Willamette	Three Sisters	No	1932	Fire Lookout	Board	Gov/Admin	Public	Poor
Rebel Rock Lookout	Willamette	Three Sisters	No	1955	Fire Lookout	Board	Gov/Admin	Public	Ruin
Red's Horse Ranch	W-Whitman	Eagle Cap	No	c. 1900	Ranch	Log	Agriculture	Admin/ Public	Fair
Standley Guard Station	W-Whitman	Eagle Cap	No	ca. 1930	Guard Station	Log	Gov/Admin	Admin	Unknown
Troughs Crew Quarters	W-Whitman	Hells Canyon	No	Unknown	Ranch	Unknown	Agriculture	None	Unknown
Tryon Creek Ranch	W-Whitman	Hells Canyon	No	ca. 1950	Ranch	Shake	Agriculture	None	Unknown
Upper Sandy Guard Station	Mount Hood	Mount Hood	Yes	1935	Guard Station	Log	Gov/Admin	None	Poor
Wisnor Place Cow Camp	W-Whitman	Hells Canyon	No	Unknown	Ranch	Metal	Agriculture	None	Ruin
Waldo Mountain Lookout	Willamette	Waldo Lake	No	1957	Fire Lookout	Plywood	Gov/Admin	Admin	Good

Table 5.2. Documents Provided by the Forest Service and the State Historic Preservation Office

FOREST	WILDERNESS	RESOURCE NAME	DATE				DOCUMENT DESCRIPTION
			ca. 1980	ca. 1990	ca. 2000	ca. 2010	
Mount Hood	Badger Creek	Kinzel Cabin	I		I		Cultural Resource Inventory, Jon Horn (1980) Cultural Resource Monitoring Report, Grady Caulk (1997)
		High Prairie Cabin	I				Cultural Resource Inventory, likely Jon Horn (ca. 1980)
	Bull of the Woods	Bull of The Woods Lookout		I			Determination of Eligibility (1993)
	Mount Hood	Timberline Trail Shelters	I	I			Cultural Resource Inventories, Jon Horn (1978, 1980) Draft Nomination to the NRHP, Gail E. Throop (1988)
		Upper Sandy Guard Station				I	Nomination to the NRHP, Jan M. Tomlinson (2009)
	Salmon-Huckleberry	Devil's Peak Lookout	I	I	I		Cultural Resource Inventory, Jon Horn (1979) Condition Assessment, Pete Cecil (1993) Section 106 form (2002)
Rogue-River Siskiyou	Sky Lakes	Honeymoon Creek Cabin			I		Nomination to the NRHP, Katherine Atwood (2000)
Wallowa-Whitman	Eagle Cap	Red's Horse Ranch			I		Historic American Building Survey, Sally Donovan and Kimberly Lakin (1996)
		Standley Guard Station			I		"Standley Guard Station Preservation Project: A Heritage Resource Consultation Report," Jacqueline Beidl (2003)
Willamette	Three Sisters	Olallie Mountain Lookout		II			Cultural Resource Site Report, Jim Cox (1991) Determination of Eligibility, James Cox (1991)
		Rebel Rock Lookout		I			Determination of Eligibility, James Cox (1991)
		Skyline Trail Shelters		I			Determination of Eligibility, James Cox (1988)
	Waldo Lake	Waldo Mountain Lookout		II			Determination of Eligibility, James Cox (1991) Cultural Resource Site Report, C. Winkler (1993)

Table 5.3. Building Types and Conditions

BUILDING TYPE	BUILDING	WALL TYPE	ROOF TYPE	WINDOW TYPE	FOUNDATION MATERIAL	WALL MATERIAL	ROOF MATERIAL	CONDITION
Fire Lookouts	Mule Peak Lookout	Stick	pyramid	horizontal slider	Stone	horizontal board	wood shingle	Good
	Waldo Mountain Lookout	Stick	Flat	vertical pivot	concrete pier	plywood	rolled composite	Good
	Bull of The Woods Lookout	Stick	pyramid	casement	concrete pier	horizontal board	wood shingle	Fair
	Devil's Peak Lookout	Stick	pyramid	horizontal pivot	concrete pier	horizontal board	wood shingle	Fair
	Rebel Rock Lookout	Stick	pyramid	casement	concrete pier	horizontal board	wood shingle	Poor
	Olallie Mountain Lookout	Stick	front gable	horizontal pivot	stone pier	horizontal board	wood shingle	Poor
Trail Shelters	Cairn Basin Shelter	Stone	shed	none	None	uncoursed stone	corrugated metal	Fair
	Cooper Spur Shelter	Stone	shed	none	None	uncoursed stone	metal panel	Good
	Elk Meadows Shelter	Log	saltbox	none	None	wood shake	wood shake	Fair
	Gnarl Ridge Shelter	Stone	shed	none	None	uncoursed stone	corrugated metal	Poor
	McNeil Point Shelter	Stone	shed	none	None	uncoursed stone	corrugated metal	Fair
Guard Stations	Millard Ranger Station	Log	front gable	horizontal slider	Concrete	horizontal log	wood shingle	Good
	Upper Sandy Guard Station	Log	side gable	horizontal slider	Stone	horizontal log	wood shingle	Poor
Cabins	Red's Horse Ranch	Log	gables	horizontal slider	concrete	horizontal log	wood shingle, corrugated metal	Fair
	Kinzel Cabin	Log	side gable	None	None	horizontal log	wood shake	Poor

Table 5.4. Use and Condition

EVIDENT USER	EVIDENT MAINTENANCE	BUILDING NAME	FOREST	WILDERNESS	BUILDING TYPE	CURRENT CONDITION
Administrative Use	Professional Maintenance	Millard Ranger Station	Wallowa-Whitman	Eagle Cap	Guard Station	Good
		Waldo Mountain Lookout	Willamette	Waldo Lake	Fire Lookout	Good
Administrative & Public Use	Professional & Improved Maintenance	Mule Peak Lookout	Wallowa-Whitman	Eagle Cap	Fire Lookout	Good
		Bull of The Woods Lookout	Mount Hood	Bull of the Woods	Lookout	Fair
Red's Horse Ranch		Wallowa-Whitman	Eagle Cap	Ranch	Fair	
Public Use		Cooper Spur	Mount Hood	Mount Hood	Trail Shelter	Good
		Devil's Peak Lookout	Mount Hood	Salmon-Huckleberry	Lookout	Fair
		Elk Meadow Shelter	Mount Hood	Mount Hood	Trail Shelter	Fair
	Improved Maintenance	Cairn Basin Shelter	Mount Hood	Mount Hood	Trail Shelter	Fair
McNeil Point Shelter		Mount Hood	Mount Hood	Trail Shelter	Fair	
No use (vacant)	Improved Maintenance	Olallie Mountain Lookout	Willamette	Three Sisters	Fire Lookout	Poor
		Upper Sandy Guard Station	Mount Hood	Mount Hood	Guard Station	Poor
	No maintenance (neglect)	Gnarl Ridge Shelter	Mount Hood	Mount Hood	Trail Shelter	Poor
		Kinzel Cabin	Mount Hood	Badger Creek	Cabin	Poor
		Rebel Rock Lookout	Willamette	Three Sisters	Fire Lookout	Poor

Table 5.5. Preservation Conditions and Opportunities

BUILDING NAME	Forest	Wilderness	PHYSICAL CONDITION	TREATMENT URGENCY	PHYSICAL INTEGRITY	OPPORTUNITY SCORE
Waldo Mountain Lookout	Willamette	Waldo Lake	Good (4)	High (4)	High (4)	12
McNeil Point Shelter	Mount Hood	Mount Hood	Fair (2)	High (4)	High (4)	10
Millard Ranger Station	Wallowa-Whitman	Eagle Cap	Good (4)	Low (1)	High (4)	9
Olallie Mountain Lookout	Willamette	Three Sisters	Poor (1)	High (4)	High (4)	9
Upper Sandy Guard Station	Mount Hood	Mount Hood	Poor (1)	High (4)	High (4)	9
Bull of the Woods Lookout	Mount Hood	Bull of the Woods	Fair (2)	Medium (2)	High (4)	8
Devil’s Peak Lookout	Mount Hood	Salmon-Huckleberry	Fair (2)	Medium (2)	High (4)	8
Elk Meadows Shelter	Mount Hood	Mount Hood	Fair (2)	Medium (2)	High (4)	8
Red’s Horse Ranch	Wallowa-Whitman	Eagle Cap	Fair (2)	Medium (2)	High (4)	8
Mule Peak Lookout	Wallowa-Whitman	Eagle Cap	Good (4)	Medium (2)	Medium (2)	8
Cooper Spur Shelter	Mount Hood	Mount Hood	Good (4)	Low (1)	Medium (2)	7
Cairn Basin Shelter	Mount Hood	Mount Hood	Fair (2)	Medium (2)	Medium (2)	6
Gnarl Ridge Shelter	Mount Hood	Mount Hood	Poor (1)	Low (1)	Low (1)	3
Kinzel Cabin	Mount Hood	Badger Creek	Poor (1)	Low (1)	Low (1)	3
Rebel Rock Lookout (burned 2017)	Willamette	Three Sisters	Poor (1)	Low (1)	Low (1)	3



Figure 5.1 Exterior (a) and interior (b) views of Waldo Mountain Lookout in the Waldo Lake Wilderness, Willamette National Forest in July 2017. This building exemplifies the correlation between administrative use, appropriate maintenance, and sustained good conditions.



Figure 5.2. Exterior (a) and interior (b) views of Devil's Peak Lookout in the Salmon-Huckleberry Wilderness, Mount Hood National Forest in July 2017. This building exemplifies the effect of no administrative use and improvised maintenance on condition.



Figure 5.3. Exterior (a) and interior (b) views of the Upper Sandy Guard Station in the Mount Hood Wilderness, Mount Hood National Forest in July 2017. This building exemplifies the correlation between no active use (administrative or otherwise), no maintenance, and poor conditions.



Figure 5.4. Preservation opportunities represented by (a) Waldo Mountain Lookout, which needs roof repairs in order to sustain its otherwise good conditions and high integrity, versus (b) Kinzel Cabin, which is in poor condition, require no urgent work items, and is a ruin.



Figure 5.5. Preservation opportunities represented by (a) McNeil Point Shelter which is in fair condition, requires urgent roof repairs, but retains its integrity, versus (b) Cooper Spur Shelter which is in good condition, has no urgent needs, and has fair integrity impacted by the addition of a non-historic standing seam roof, rubber curtain, and orange spray foam insulation.



Figure 5.6. Preservation opportunities represented by (a) Olallie Mountain Lookout, which is in poor condition but retains integrity, versus (b) Mule Peak Lookout which is in good condition but has sustained some losses to integrity.

CHAPTER VI

HERITAGE AS REMEDY TO THE TROUBLE WITH WILDERNESS

The ecocritic Hannes Bergthaller has identified a ‘paradox’ in the field of environmentalism that seems to be a source of its richness and vitality:

“Environmentalism is caught up in a paradox: it wishes to speak on behalf of the whole constituted by society and its biophysical environment, but it can only do so in terms provided by society itself; it argues that humans need to recognize themselves as *a part* of nature, but the very possibility of this argument is predicated on society standing *apart* from nature. ... [This is] not as a defeat [...] but rather a necessary and enabling condition.”¹

Paradox is a source of vitality and inspiration that encourages a complex understanding of the world. I believe that Bergthaller’s evocation of a paradox being both necessary and enabling also describes the opportunity presented by historic resources in wilderness.

When we consider the existence of a historic fire lookout, a cabin, or a trail shelter in wilderness the problematic or challenging situation that each evokes should be embraced as an opportunity to expand our understanding and think in complex terms. Paradox is a condition that will cause historians, ecologists, and recreationists to continually engage in complex conversations that expand our collective ability to comprehend the world. We should preserve and protect historic sites in wilderness

¹ Hannes Bergthaller, “Paradox as Bedrock: Social Systems Theory and the Ungrounding of Literary Environmentalism in Edward Abbey’s *Desert Solitaire*,” in *Handbook of Ecocriticism and Cultural Ecology*, ed. Hubert Zapf (Boston: Walter de Gruyter, 2016), 56.

because, along with that invigorating paradox, they also engage people in that conversation in a multitude of ways.

Wilderness ideology offers a useful term, untrammelled, which can mean that an experience is neither confined, nor inhibited. When we talk about the ways in which people might interact with historic sites in wilderness, it may be beneficial to emphasize that their experience should be continuous with the untrammelled character of wilderness. This ethic promotes access and allows individuals to direct their own experience. The opportunity of paradox does not need to be known immediately and it does not need to have a single, clearly defined source of significance.

In wilderness, an untrammelled interaction with human history could take many forms. One person might look out the window of a guard station and understand the literal perspective of a person who built it decades earlier, pondering why they chose this site. Another person might notice fruit trees from a former orchard and then come upon a cabin and perceive that the residents had planted and tended those trees to sustain their livelihood. Others might sleep inside a fire lookout, wake up in the cold dark, go out on a catwalk and photograph a sunrise, and then return home to share their experience with other people. Each intact, accessible historic building in wilderness facilitates a range of interactions with the natural world through its roots in the past, disposition in the present, and potential in the future (Figure 6.1).

In many ways, historic preservation and wilderness preservation have similar troubles, (to borrow William Cronon's meaning). Heritage professionals can also challenge their elitist roots by telling the stories "everyday people in extraordinary

places,” as Laura Kirn describes, but even the study of vernacular architecture, there is still some difficulty in communicating the value of historic places to a wide audience. Abandoned structures in remote places are easily overlooked or perceived to be irrelevant, in part because traditional interpretive strategies are not all that effective in vernacular settings.

The study of vernacular architecture has narrowed to a focus on academia and documentation, in a trend that Susan Garfinkel calls “itemness” in her article “Recovering Performance for Vernacular Architecture Studies.” Garfinkle asserts that preservationists have become too inclined to “unite around how scholars use buildings” rather than “how their builders, occupants or visitors” used them or still use them.² She observes that the field of preservation will benefit by engaging a wide audience to understand vernacular historic resources and by rescuing these sites from the ironic elitism of academic study.

I think that the physical acts of restoring, maintaining, visiting, and occupying these historic buildings in wilderness offer ideal opportunities to experience human history in a wild setting. Many of these buildings were constructed with the intention that they would be occupied and therefore they are often appropriate sites for the public to visit and even stay overnight in. They are not, for instance, built of particularly fragile materials, equipped with priceless furnishings, or dangerous (if they are kept in good condition). Furthermore, these buildings are small and were shaped using traditional

² Susan Garfinkel, “Recovering Performance for Vernacular Architecture Studies,” *Perspectives in Vernacular Architecture* 13 (2006):106.

building techniques that can be taught and replicated without power tools and heavy equipment.

We should advocate for these opportunities because they serve a purpose through what Garfinkel calls the “performance” of everyday history. In this context, “performance” is used to imply “presence, action, audience, and the creation of meanings across the passage of time.”³ I think it means a personal encounter and connection with some element of history. Working on these buildings and sharing them provides a depth and vitality cannot be achieved with a photograph in a brochure.

This study reveals that many opportunities for further interdisciplinary thought and action are waiting to be explored. Given that the Wilderness Act recognizes that wilderness areas may include historic resources, it is not necessary to erase them. These are historical landscapes with a history of settlement, productivity, and recreation. The presence of historic resources in wilderness actually tests our paradoxical ideals, and each historic site offers a rare chance to encounter interwoven stories about people and nature. There is no need to abandon these sites, because their preservation is feasible and beneficial. Preservation offers the potential far for more interesting outcomes than erasure ever could.

³ Garfinkel, “Recovering Performance for Vernacular Architecture Studies,” 106.

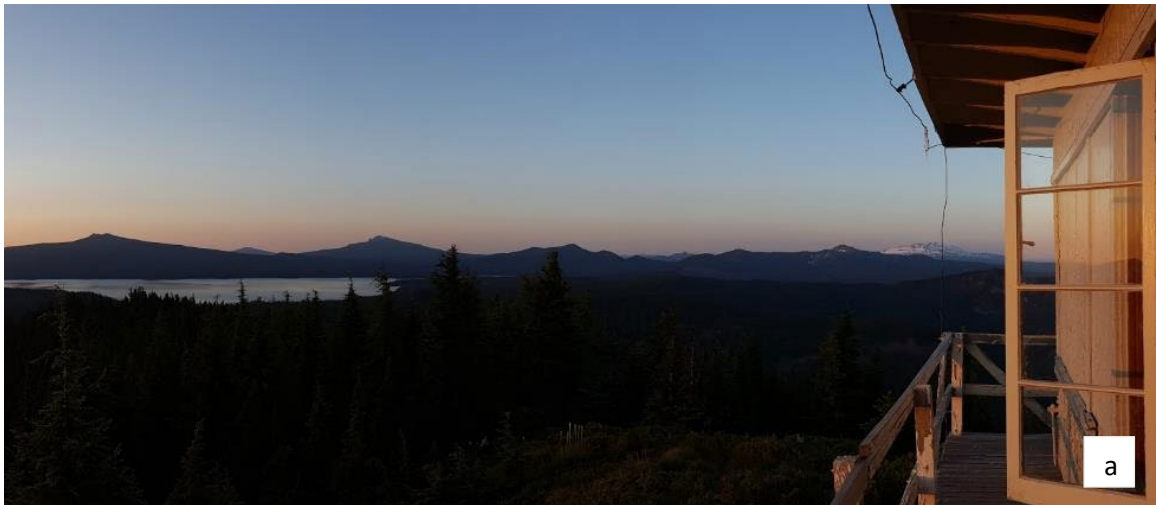

Figure 6.1. Experiential values supported by historic sites in wilderness that are actively maintained and used, as demonstrated by (a) sunset over Waldo Lake Wilderness seen from the catwalk of Waldo Mountain Lookout and (b) horses used by caretakers to steward the Eagle Cap Wilderness, corralled at the barn on Red's Horse Ranch.

APPENDIX A:

MINIMUM REQUIREMENTS DECISION GUIDE



ARTHUR CARHART NATIONAL WILDERNESS TRAINING CENTER

**MINIMUM REQUIREMENTS
DECISION GUIDE
WORKBOOK**

“...except as necessary to meet minimum requirements for the administration of the area for the purpose of this Act...”

-- The Wilderness Act of 1964

Project Title:

Cultural resource condition assessments for historic structures

MRDG Step 1: Determination

Determine if Administrative Action is Necessary

Description of the Situation

What is the situation that may prompt administrative action?

A number of historic structures—such as guard stations, shelters, cabins, and lookouts—are located in areas that have been subsequently designated as wilderness. The Forest Service is responsible to manage cultural resources in accordance with the National Historic Preservation Act. The agency periodically monitors the condition of cultural resources by conducting cultural resource condition assessments. The results of these assessments inform the agency’s implementation of protection measures for each structure. Protection measures may include but are not limited to decisions to remove, maintain, or allow a structure to deteriorate naturally. Cultural resource condition assessments may also help to inform the treatment of historic structures in a wilderness character narrative.

The R6 Heritage Program in collaboration with a graduate student in the Historic Preservation Program at the University of Oregon has identified as priorities at least 16 historic structures in 7 Forest Service-managed wilderness areas in Oregon that do not have recent cultural resource condition assessments.

Mt. Hood National Forest

Badger Creek Wilderness

- Kinzel Cabin

Bull of the Woods Wilderness

- Bull of the Woods Lookout

Mount Hood Wilderness

- Cairn Basin Shelter
- Cooper Spur Trail Shelter
- Elk Meadows Shelter
- Gnarl Ridge Trail Shelter
- McNeil Point Shelter
- Upper Sandy Guard Station

Rogue River-Siskiyou National Forest

Sky Lakes Wilderness

- Honeymoon Snow Survey Cabin

Wild Rogue Wilderness

- Brushy Bar Guard Station

Willamette National Forest

Three Sisters Wilderness

- Olallie Mountain Lookout
- Rebel Rock Lookout
- James Creek Shelter
- Mink Lake Shelter
- Cliff Lake Shelter

Waldo Lake Wilderness

- Waldo Lookout

Options Outside of Wilderness

Can action be taken outside of wilderness that adequately addresses the situation?

- YES **STOP – DO NOT TAKE ACTION IN WILDERNESS**
- NO **EXPLAIN AND COMPLETE STEP 1 OF THE MRDG**

Explain:

These historic structures are located within wilderness. Information available through remote sensing, archives/records, and other existing documentation would not be adequate to evaluate the current condition of these structures.

Criteria for Determining Necessity

Is action necessary to meet any of the criteria below?

A. Valid Existing Rights or Special Provisions of Wilderness Legislation

*Is action necessary to satisfy valid existing rights or a special provision in wilderness legislation (the Wilderness Act of 1964 or subsequent wilderness laws) that **requires** action? Cite law and section.*

YES NO

Explain:

N/A

B. Requirements of Other Legislation

Is action necessary to meet the requirements of other federal laws? Cite law and section.

YES NO

Explain:

National Historic Preservation Act section 106 requires federal agencies to take into account the effects of their undertakings on historic properties, and requires the agency to evaluate historical or cultural importance of cultural resources on National Forest System lands to determine National Register eligibility under NHPA and 36 CFR 60. FSH 2309.12 on Heritage Program Management provides guidance, direction and justifications for conducting assessments of historic properties in Wilderness (see "Other Direction").

C. Wilderness Character

Is action necessary to preserve one or more of the five qualities of wilderness character?

UNTRAMMELED

YES NO

Explain:

N/A

UNDEVELOPED

YES NO

Explain:

N/A

NATURAL

YES NO

Explain:

N/A

SOLITUDE OR PRIMITIVE & UNCONFINED RECREATION

YES NO

Explain:

N/A

OTHER FEATURES OF VALUE

YES NO

Explain:

Whether and how these historic structures contribute to wilderness character for the respective wilderness areas in which they are located has not yet been formally evaluated through wilderness character narrative or other process. Information gathered through cultural resource assessment surveys could help to inform future evaluation and any appropriate protection measures.

Step 1 Decision

Is administrative action necessary in wilderness?

Decision Criteria

A. Existing Rights or Special Provisions YES NO

B. Requirements of Other Legislation YES NO

C. Wilderness Character

Untrammeled YES NO

Undeveloped YES NO

Natural YES NO

Outstanding Opportunities YES NO

Other Features of Value YES NO

Is administrative action necessary in wilderness?

YES

EXPLAIN AND PROCEED TO STEP 2 OF THE MRDG

NO

STOP – DO NOT TAKE ACTION IN WILDERNESS

Explain:

Cultural resource condition assessments should be periodically conducted for historic structures in wilderness in order to ensure the Forest Service is meeting its responsibilities under both the Wilderness Act (to protect other features of value where they are a quality of wilderness character) and the National Historic Preservation Act.

Cultural resource condition assessments involve on-the-ground fieldwork in wilderness to collect information about the current condition of historic structures.

MRDG Step 2

Determine the Minimum Activity

Other Direction

Is there “special provisions” language in legislation (or other Congressional direction) that explicitly allows consideration of a use otherwise prohibited by Section 4(c)?

AND/OR

Has the issue been addressed in agency policy, management plans, species recovery plans, or agreements with other agencies or partners?

YES

DESCRIBE OTHER DIRECTION

NO

SKIP AHEAD TO TIME CONSTRAINTS BELOW

Describe Other Direction:

Special provisions: N/A

Agency policy:

FSM 2323.83 – Studies and Management

As a general rule, cabins, shelters, and other structures approaching 50 years of age should be examined for their cultural resource value. ... Management direction for cultural resources eligible for nomination to the National Register is subject to compliance with section 106 of the National Historic Preservation Act and 36 CFR 800 (FSM 2366). A decision to remove, maintain, or allow a historic or prehistoric structure to deteriorate naturally is a Federal undertaking that will affect the cultural resource.

FSM 2364.3 – Long-term Protection

The agency official is responsible for systematic monitoring of cultural resources, evaluating and documenting their condition and vulnerability to human-cause or environmental degradation, and implementing necessary long-term protection measures.

FSM 2364.2 – Cultural Resource Condition Assessments

Heritage professionals are responsible for documenting and maintaining cultural resource condition assessments to standard in the Forest Service Infra heritage database and Heritage Program records. Periodic monitoring and condition assessments are the basis for applying protective measures and treatments to vulnerable, deteriorating, or threatened cultural resources.

FSH 2309.12 – Heritage Program Management

CHAPTER 40 – PROTECTION AND STEWARDSHIP

Enlist Forest Service employees, volunteers, and cooperators (for example, local universities, Tribes, and archaeological societies) to assist in cultural resource monitoring and documenting site conditions.

Develop a Historic Property Plan (HPP) for Priority Heritage Assets (PHAs), individual historic properties, and classes of similar historic properties to guide their long-term management and protection.

Time Constraints

What, if any, are the time constraints that may affect the action?

Many of these structures are in high-elevation areas. Roads and trails may be impassable due to snow except during summer (typically June-September, though this varies by location and year). Additionally, stream crossings may be more dangerous in spring and early summer when streams run higher and faster due to snowmelt.

However, summer also coincides with the highest levels of public visitation for most of these wilderness areas. Visitation is typically highest on summer weekends.

Components of the Action

What are the discrete components or phases of the action?

Component 1:	Mobilize personnel and equipment
Component 2:	Conduct cultural resource condition assessment
Component 3:	Condition of site/historic structure after assessment

Proceed to the alternatives.

Refer to the [MRDG Instructions](#) regarding alternatives and the effects to each of the comparison criteria.

46.26 – Cultural Resources in Specially Designated Areas

Identify and evaluate cultural resources in specially designated areas in accordance with NHPA Section 106 and 110 and 36 CFR 60.4.

When evaluating cultural resources within a designated area, take into consideration the unique characteristics of the designation in addition to the criteria of eligibility to the National Register in 36 CFR 60.4.

Follow the guidelines of the specific designated area's management plan or policy when conducting cultural resource identification and evaluation within that designated area. ...conduct a Minimum Requirements Decision Guide process before ... identification and evaluation of historic properties within a Congressionally-designated Wilderness (see FSM 2320).

CHAPTER 30 - IDENTIFICATION, EVALUATION, AND ALLOCATION TO MANAGEMENT USE CATEGORIES

33.6 – Cultural Resources in Specially Designated Areas

Regardless of the special designation of an area, evaluate cultural resources in accordance with National Register criteria in 36 CFR 60.4 and follow the standard procedures of documentation and consultation with SHPO and Indian Tribes.

When evaluating cultural resources within a specially designated area, follow the policy and guidelines for the specific designation that may affect the tools and methodologies used to carry out the evaluation.

CHAPTER 40 – PROTECTION AND STEWARDSHIP

41 – CULTURAL RESOURCE MONITORING

Systematically monitor Priority Heritage Assets (PHAs), historic properties, and unevaluated cultural resources and document their physical condition in a condition assessment. .

For cultural resource monitoring update cultural resource condition information in Heritage Program records and the NRM database; report damage or potential threats to historic properties and unevaluated cultural resources; and, incorporate cultural resource protection needs into Heritage Program Plans and Historic Property Plans.

41.1 – Condition Assessment

Prepare and update condition assessments for PHAs including all heritage assemblages to identify protection and management needs and corrective actions; maintain condition assessments that are no older than 5 years for all PHAs; document the condition of the resource in NRM Heritage and in Heritage Work items.

Condition assessments may be qualitative (narrative) or quantitative (metrics, ratings), or both, and usually include a description, photographs, drawings, and maps

41.2 – Volunteers and Site Stewardship Programs

MRDG Step 2: Alternatives

Alternative 1: Conduct condition assessments for historic structures

Description of the Alternative

What are the details of this alternative? When, where, and how will the action occur? What mitigation measures will be taken?

Under a Participating Agreement between Region 6 and HistoriCorps, a HistoriCorps intern (Lead PI) will lead a team of volunteers (up to 10, depending on conditions and work needed at each site) to conduct cultural resource condition assessments for approximately 15 historic structures in wilderness areas on the Mt. Hood National Forest, Rogue River-Siskiyou National Forest, and Willamette National Forest.

HistoriCorps is an Agency-funded program that engages volunteers and students in the preservation trades to save public places on public lands and their gateway communities. HistoriCorps helps public land managers preserve important historic structures by enlisting volunteers and helping teach them traditional building skills during the course of the project. (FSH 2309.12, 53.24)

Fieldwork will be broken into a series of 2- to 6-day hitches, with approximately 40 total days of fieldwork in wilderness. The Lead PI will coordinate with the Forest Archaeologist and Wilderness Manager(s) to schedule hitches and obtain any necessary permits. Travel/work will not involve any limited entry areas.

Personnel will travel by foot using system trails to minimize cross-country travel, where necessary, to access historic structures. The number of personnel—expected to be a party of 1 to 4--will be within the maximum party size for the wilderness area. The Lead PI will coordinate with the Forest Archaeologist and Wilderness Manager(s) on areas for camping, and will follow all wilderness regulations and Leave No Trace principles for selecting campsites and other aspects of wilderness travel.

Lead PI will lead team of volunteers to implement protocol for cultural resource condition assessments. The methodology includes extensive use of high-resolution digital photography, measurements of relevant structural and architectural building details, sketches, and written notes. The assessment includes systematic evaluation and documentation of the existing conditions of the structure, including roof sheathing and framing; walls; interior finishes including floors and floor systems; window and door openings; foundations; and aspects of the building site such as fences, drainages, and landscape features. The assessment also uses building/site-specific architectural criteria such as architectural integrity to make a brief, field-based recommendation for Determination of Eligibility in accordance with NHPA. Finally, the assessment notes materials that would be needed for any future

maintenance/replacement work and, if relevant, any potential local sources of native materials.

Tools, equipment, materials, and PPE used in condition assessments include:

- 25' tape measure
- 50' tape measure
- Laser measure¹
- Adjustable bevel gauge
- Torpedo level
- Hand rake²
- Knife with minimum 3" blade²
- Flathead screwdriver³
- Hammer and nails³
- Camera, spare battery, and memory cards¹
- Smartphone, spare batteries, and touchscreen pen¹
- Solar charger
- Rite in the Rain notebooks
- Pens and pencils
- Permanent marker
- Sandwich bags
- Maps
- Forest Service-provided Yale key
- Forest Service-provided radio¹
- Hardhat

No motorized equipment, mechanical transport, installations, or other prohibited uses under Section 4(c) of the Wilderness Act will be used.

¹ = Motorized equipment means any equipment having or using an engine or motor, *except small battery-powered handheld devices* such as cameras, shavers, flashlights, and Geiger counters.

No repairs, stabilization, restoration, or reconstruction will be performed.

² = These tools will be used only for the purpose of monitoring and documentation for the purpose of the cultural resource condition assessment.

³ = These tools are included to allow the Lead PI to secure any doors or windows that are found to have been forced open or vandalized, to keep in place any barriers to entry that managers have put in place for public safety and/or resource protection.

All tools, materials, supplies, and PPE will be removed from the site at the end of each day of fieldwork and stored with personnel at staging area (campsite in wilderness), and will be packed out of wilderness by personnel on foot, at the end of each hitch.

Component Activities

How will each of the components of the action be performed under this alternative?

<u>Component of the Action</u>		Activity for this Alternative
1	Mobilize personnel and equipment	Personnel will travel to and from the site by foot. Equipment will be transported by foot.
2	Conduct cultural resource condition assessment	Personnel will follow standardized protocol to conduct cultural resource condition assessment of historic structure. No motorized equipment or mechanical transport will be used, and there will be no installations.
3	Condition of site following cultural resource condition assessment	Equipment will be removed from the site with personnel immediately following assessment, and will leave no marks or other impacts on the structure.

Wilderness Character

What is the effect of each component activity on the qualities of wilderness character? What mitigation measures will be taken?

UNTRAMMELED

<u>Component Activity for this Alternative</u>		Positive	Negative	No Effect
1	Personnel will travel to and from the site by foot. Equipment will be transported by foot.	<input type="checkbox"/>	<input type="checkbox"/>	<input checked="" type="checkbox"/>
2	Personnel will follow standardized protocol to conduct cultural resource condition assessment of historic structure. No motorized equipment or mechanical transport will be used.	<input type="checkbox"/>	<input type="checkbox"/>	<input checked="" type="checkbox"/>
3	Equipment will be removed immediately following assessment and will leave no marks or other impacts on the structure.	<input type="checkbox"/>	<input type="checkbox"/>	<input checked="" type="checkbox"/>
Total Number of Effects		0	0	NE
<u>Untrammeled Total Rating</u>		0		

Explain:

There will be no effects to the untrammeled quality.

UNDEVELOPED

<u>Component Activity for this Alternative</u>		Positive	Negative	No Effect
1	Personnel will travel to and from the site by foot. Equipment will be transported by foot.	<input type="checkbox"/>	<input type="checkbox"/>	<input checked="" type="checkbox"/>
2	Personnel will follow standardized protocol to conduct cultural resource condition assessment of historic structure. No motorized equipment or mechanical transport will be used.	<input type="checkbox"/>	<input type="checkbox"/>	<input checked="" type="checkbox"/>
3	Equipment will be removed immediately following assessment and will leave no marks or other impacts on the structure.	<input type="checkbox"/>	<input type="checkbox"/>	<input checked="" type="checkbox"/>
Total Number of Effects		0	0	NE
<u>Undeveloped Total Rating</u>		0		

Explain:

There will be no motorized equipment, mechanical transport, or installations.

NATURAL

<u>Component Activity for this Alternative</u>		Positive	Negative	No Effect
1	Personnel will travel to and from the site by foot. Equipment will be transported by foot.	<input type="checkbox"/>	<input type="checkbox"/>	<input checked="" type="checkbox"/>
2	Personnel will follow standardized protocol to conduct cultural resource condition assessment of historic structure. No motorized equipment or mechanical transport will be used.	<input type="checkbox"/>	<input type="checkbox"/>	<input checked="" type="checkbox"/>
3	Equipment will be removed immediately following assessment and will leave no marks or other impacts on the structure.	<input type="checkbox"/>	<input type="checkbox"/>	<input checked="" type="checkbox"/>
Total Number of Effects		0	0	NE
<u>Natural Total Rating</u>		0		

Explain:

Personnel will use system trails to access structures and minimize any cross-country travel. They will follow wilderness regulations and will use Leave No Trace principles. The presence of personnel conducting fieldwork will be short-term (no more than 6 days of fieldwork, including hiking in/out, at any one site) and effects to the natural quality are not expected to differ from a party of wilderness visitors camping and hiking in the area. The cultural resource

condition assessment involves no ground disturbance or ground clearing. Noise impacts would be no louder than human voices and so are not expected to affect wildlife.

SOLITUDE OR PRIMITIVE & UNCONFINED RECREATION

<u>Component Activity for this Alternative</u>		Positive	Negative	No Effect
1	Personnel will travel to and from the site by foot. Equipment will be transported by foot.	<input type="checkbox"/>	<input type="checkbox"/>	<input checked="" type="checkbox"/>
2	Personnel will follow standardized protocol to conduct cultural resource condition assessment of historic structure. No motorized equipment or mechanical transport will be used.	<input type="checkbox"/>	<input checked="" type="checkbox"/>	<input type="checkbox"/>
3	Equipment will be removed immediately following assessment and will leave no marks or other impacts on the structure.	<input type="checkbox"/>	<input type="checkbox"/>	<input checked="" type="checkbox"/>
Total Number of Effects		0	-1	NE
<u>Solitude or Primitive & Unconfined Rec. Total Rating</u>		-1		

Explain:

Personnel consist of Lead PI and a small team of volunteers (1 to 3 per hitch). Total personnel would not exceed party size limitation for the wilderness area. Wilderness visitors may encounter personnel traveling to and from the site on trails and camping in the vicinity of the site. Wilderness visitors may encounter personnel conducting cultural resource condition assessments of historic structures, may see personnel visible at historic structures (e.g., lookouts), and/or may hear human voices as personnel conduct assessments.

For each structure, fieldwork to travel to and from the site and conduct the assessment is expected to take 2 to 6 days. Total field time for all wilderness areas and structures is estimated to be 40 days. Schedule will be determined with the Forest Archaeologist in coordination with the wilderness manager(s), who may advise, for example, conducting fieldwork on weekdays to minimize the number of wilderness visitors impacted.

No closures of trails or areas are proposed. The public may continue to visit historic structures while assessments are being conducted.

The negative effects to opportunities for solitude of encountering personnel traveling on trails or conducting fieldwork at historic structures are limited, short-term (only while personnel are in the field), and temporary. On the trail, a party of 1 to 4 personnel traveling by foot would not likely appear distinguishable from other small parties of wilderness visitors. For this reason, travel would have no effect on opportunities for solitude.

OTHER FEATURES OF VALUE

<u>Component Activity for this Alternative</u>		Positive	Negative	No Effect
1	Personnel will travel to and from the site by foot. Equipment will be transported by foot.	<input type="checkbox"/>	<input type="checkbox"/>	<input checked="" type="checkbox"/>
2	Personnel will follow standardized protocol to conduct cultural resource condition assessment of historic structure. No motorized equipment or mechanical transport will be used.	<input checked="" type="checkbox"/>	<input type="checkbox"/>	<input type="checkbox"/>
3	Equipment will be removed immediately following assessment and will leave no marks or other impacts on the structure.	<input type="checkbox"/>	<input type="checkbox"/>	<input checked="" type="checkbox"/>
Total Number of Effects		1	0	NE
<u>Other Features of Value Total Rating</u>		1		

Explain:

Cultural resource condition assessments will give managers information on current conditions to determine and implement appropriate protective measures for structures in wilderness and to allow managers to identify and describe in future wilderness character narratives those historic structures that are other features of value for wilderness character.

Summary Ratings for Alternative 1

Wilderness Character	
<u>Untrammeled</u>	0
<u>Undeveloped</u>	0
<u>Natural</u>	0
<u>Solitude or Primitive & Unconfined Recreation</u>	-1
<u>Other Features of Value</u>	1
Wilderness Character Summary Rating	0

MRDG Step 2: Alternatives

Alternative 2: No Action

Description of the Alternative

What are the details of this alternative? When, where, and how will the action occur? What mitigation measures will be taken?

Condition assessments would not be conducted to monitor and document current conditions of historic structures in these wilderness areas.

Component Activities

How will each of the components of the action be performed under this alternative?

<u>Component of the Action</u>		Activity for this Alternative
1	Mobilize personnel and equipment	Not required
2	Conduct cultural resource condition assessment	No assessments are conducted
3	Condition of site following cultural resource condition assessment	No change

Wilderness Character

What is the effect of each component activity on the qualities of wilderness character? What mitigation measures will be taken?

UNTRAMMELED

<u>Component Activity for this Alternative</u>		Positive	Negative	No Effect
1	Not required	<input type="checkbox"/>	<input type="checkbox"/>	<input checked="" type="checkbox"/>
2	No assessments are conducted	<input type="checkbox"/>	<input type="checkbox"/>	<input checked="" type="checkbox"/>
3	No change	<input type="checkbox"/>	<input type="checkbox"/>	<input checked="" type="checkbox"/>
Total Number of Effects		0	0	NE
<u>Untrammeled Total Rating</u>		0		

Explain:

There will be no effects to the untrammeled quality.

UNDEVELOPED

<u>Component Activity for this Alternative</u>		Positive	Negative	No Effect
1	Not required	<input type="checkbox"/>	<input type="checkbox"/>	<input checked="" type="checkbox"/>
2	No assessments are conducted	<input type="checkbox"/>	<input type="checkbox"/>	<input checked="" type="checkbox"/>
3	No change	<input type="checkbox"/>	<input type="checkbox"/>	<input checked="" type="checkbox"/>
Total Number of Effects		0	0	NE
<u>Undeveloped Total Rating</u>		0		

Explain:

There will be no effects to the undeveloped quality.

NATURAL

<u>Component Activity for this Alternative</u>		Positive	Negative	No Effect
1	Not required	<input type="checkbox"/>	<input type="checkbox"/>	<input checked="" type="checkbox"/>
2	No assessments are conducted	<input type="checkbox"/>	<input type="checkbox"/>	<input checked="" type="checkbox"/>
3	No change	<input type="checkbox"/>	<input type="checkbox"/>	<input checked="" type="checkbox"/>
Total Number of Effects		0	0	NE
<u>Natural Total Rating</u>		0		

Explain:

There will be no effects to the natural quality.

SOLITUDE OR PRIMITIVE & UNCONFINED RECREATION

<u>Component Activity for this Alternative</u>		Positive	Negative	No Effect
1	Not required	<input type="checkbox"/>	<input type="checkbox"/>	<input checked="" type="checkbox"/>
2	No assessments are conducted	<input type="checkbox"/>	<input type="checkbox"/>	<input checked="" type="checkbox"/>
3	No change	<input type="checkbox"/>	<input type="checkbox"/>	<input checked="" type="checkbox"/>
Total Number of Effects		0	0	NE
<u>Solitude or Primitive & Unconfined Rec. Total Rating</u>		0		

Explain:

There will be no effects to opportunities for solitude or primitive and unconfined recreation.

OTHER FEATURES OF VALUE

Component Activity for this Alternative		Positive	Negative	No Effect
1	Not required	<input type="checkbox"/>	<input type="checkbox"/>	<input checked="" type="checkbox"/>
2	No assessments are conducted	<input type="checkbox"/>	<input checked="" type="checkbox"/>	<input type="checkbox"/>
3	No change	<input type="checkbox"/>	<input type="checkbox"/>	<input checked="" type="checkbox"/>
Total Number of Effects		0	-1	NE
Other Features of Value Total Rating		-1		

Explain:

Cultural resource condition assessments would not be conducted. Managers would not have information on current conditions of historic structures to implement appropriate protective measures. Information from assessments would not be available to support development of the wilderness character narrative and identification in the narrative of which, if any, historic structures constitute other features of value for wilderness character.

Summary Ratings for Alternative 2

Wilderness Character	
Untrammeled	0
Undeveloped	0
Natural	0
Solitude or Primitive & Unconfined Recreation	0
Other Features of Value	-1
Wilderness Character Summary Rating	-1

MRDG Step 2: Alternatives Not Analyzed

Alternatives Not Analyzed

What alternatives were considered but not analyzed? Why were they not analyzed?

Fewer personnel: An alternative that would involve fewer personnel (Lead PI and 1 additional intern) to conduct cultural resource condition assessments was considered. While this could limit impacts to opportunities for solitude by making it so that wilderness visitors encountering the party would see/hear fewer individuals, it would not substantially change the experience of encountering a party conducting field work. Having fewer personnel could make fieldwork less efficient, resulting in more time needed at each site. It also would not have the public education benefit of involving volunteers in stewardship of wilderness / cultural resources. The action alternative that was analyzed, Alternative 1, provides flexibility for the Lead PI to involve the number of volunteers appropriate to the fieldwork needs for each site (within the maximum party size regulation for the wilderness area.)

Conduct assessments using a different approach and/or in a future year: This MRDG does not include alternatives that would use a different approach to conduct cultural resource condition assessments (e.g., Forest Service staff, different methodology, etc.) or conduct assessments on a different timeframe. These possibilities were not analyzed, because selecting the No Action alternative (Alternative 2) would preserve the opportunity to propose a different approach or different timing in the future.

MRDG Step 2: Alternative Comparison

[Alternative 1:](#) Conduct condition assessments for historic structures

[Alternative 2:](#) No Action

Wilderness Character	Alternative 1		Alternative 2	
	+	-	+	-
Untrammeled	0	0	0	0
Undeveloped	0	0	0	0
Natural	0	0	0	0
Solitude/Primitive/Unconfined	0	-1	0	0
Other Features of Value	1	0	0	-1
Total Number of Effects	1	-1	0	-1
Wilderness Character Rating	0		-1	

MRDG Step 2: Determination

Refer to the [MRDG Instructions](#) before identifying the selected alternative and explaining the rationale for the selection.

Selected Alternative

- | | | |
|--------------------------|--------------------------------|---|
| <input type="checkbox"/> | Alternative 1: | Conduct condition assessments for historic structures |
| <input type="checkbox"/> | Alternative 2: | No Action |

Explain Rationale for Selection:

Describe Monitoring & Reporting Requirements:

If Alternative 1 is selected, HistoriCorps will prepare and submit a completed assessment report (with photos) for all the sites evaluated. The report will be provided to the R6 Heritage Program Lead on or before December 15, 2017, for review to assure that the report meets relevant professional and agency standards.

Approvals

Which of the prohibited uses found in Section 4(c) of the Wilderness Act are approved in the selected alternative and for what quantity?

<u>Prohibited Use</u>	<u>Quantity</u>
<input type="checkbox"/> Mechanical Transport:	
<input type="checkbox"/> Motorized Equipment:	
<input type="checkbox"/> Motor Vehicles:	
<input type="checkbox"/> Motorboats:	
<input type="checkbox"/> Landing of Aircraft:	
<input type="checkbox"/> Temporary Roads:	
<input type="checkbox"/> Structures:	
<input type="checkbox"/> Installations:	
NO PROHIBITED USES PROPOSED OR APPROVED	

Record and report any authorizations of Wilderness Act Section 4(c) prohibited uses according to agency policies or guidance.

Refer to agency policies for the following review and decision authorities:

Prepared	Name	Position	
	Becky Blanchard	R6 WWSR Program Manager	
	Signature		Date

Prepared	Name	Position	
	Jeff Walker	R6 Heritage Program Manager	
	Signature		Date

Recommended	Name	Position	
	Signature		Date

Recommended	Name	Position	
	Signature		Date

Approved	Name	Position	
	Signature		Date

APPENDIX B:
ASSESSMENT PROCEDURES

Step 1: Access the Building. Take notes about the condition of access routes along the way to each historic resource. One member of the party should keep a small notebook and pen in an accessible pocket and record information about the condition of roads, trailheads, and trails. Take note of the capacity of roads and trailhead. type and size of vehicles and trailers that roads and trailheads can accommodate. Once on the trail, record the location of creek crossings, potential campsites, and drinking water sources. Observe the current conditions but also consider how conditions might be different in other seasons. Since future work could involve stock animals or helicopters (as allowed), take note of conditions that allow stock animals to use trails, graze, and drink water, and record the location of former helicopter pads (Figure 1).

Step 2: Photograph the Site. Before any investigative work is done at the historic site, keep party members and gear at a distance while one person photographs the site and exterior of the structures from multiple angles (Figure 2). The photographer or an assistant should keep a log that specifies the camera angle and subject of each photo.

Step 3. Photograph the Exterior. The photographer should systematically photograph the exterior in a manner that could simulate a photographic tour later on. Begin at the front door and circle the structure multiple times, taking a different series of photos with each circuit, and consistently circling in the same direction. Document the foundation at grade, the walls, the windows, and then the roof's edge. Do not focus on condition yet (Figure 3).

Step 4. Open-up the Building. These structures are often secured against trespassers and are visually transformed as you gain access. Unlock and open doors, shutters, windows, and hatches that access a crawlspace or attic. Carefully remove tarps, plywood, cables and other materials that may have been installed to secure the building. Move trash, tools, and other debris that may be in the way, but do not remove these items as they are relevant to the building's condition. It may not be practical to open every door, window, and shutter, but the investigator should try to let in natural light and make the building accessible so that it can be studied in detail (Figure 4).

Step 5. Photograph the Interior. The photographer should systematically photograph the interior in a manner that could simulate a photographic tour later on. Begin at the front door and circle the room multiple times, taking a different series of photos with each circuit, and consistently circling in the same direction. Document the construction of floors, walls, windows, doors, ceilings, and attics. Do not focus on condition yet (Figure 5).

Step 6. Record Physical Description and Existing Conditions. The party should systematically investigate each architectural system, beginning with the exterior at the foundation and then the interior at the floor. Exterior systems include the foundation, wall cladding, wall structure, chinking and daubing, doors, windows, shutters, trim, finishes, hardware, roof cladding, and roof structure. Interior systems include the floor, wall cladding, trim, finishes, chinking and daubing, windows, hardware, ceiling, and furniture. Look for evidence of rodent or insect activity, vandalism, fire hazards (such as a broken stove or absent fire extinguisher). Record these findings with sketches and notes. This stage should not rely on photography (conducted in Step 8). Instead, build a brief but

complete written description of the building's design and condition (Figure 6).

Step 7. Record Treatment Recommendations. Each team should discuss strategies for addressing the conditions that have been observed and recorded. Where work is needed, describe the materials that need to be replaced in terms of their size and shape. Also describe the degree to which each material or architectural system needs to be replaced, by linear feet, square footage, or a percentage of the overall system. Observe the current conditions but also consider how conditions might be different in other seasons. Document materials and tools that are already stored on site. Identify spaces where a crew might stage materials, and spaces where a crew might work comfortably and safely to repair the building (Figure 7).

Step 8. Photograph Condition. The photographer should systematically photograph the exterior and interior by focusing on the condition of each architectural system. Record specific areas of damage, but also record the typical condition of each architectural system. Take care to photograph each architectural system (Step 6) and work item (Step 7). This series of photographs can include tape measures, awls, and other tools that help demonstrate the relative size and severity of damaged areas (Figure 8).

Step 9. Close the Building. Secure the structure with whatever materials and mechanisms were in use before the assessment. Improve the security measures as needed, within reason. Do not alter the security systems in any substantial way that might infringe on the resource manager's plan for that property. Pack out everything that you brought to the site. It is reasonable to remove some additional trash found on site, but this should not be a substantial undertaking (Figure 9).



Figure 1. Record of trail conditions on the route to Waldo Mountain Lookout



Figure 2. Photo of overall form and conditions, Waldo Mountain Lookout



Figure 3. Photo tour of exterior features



Figure 4. Volunteer John Milliken removes shutters to provide light inside the lookout



Figure 5. Photo tour of interior features



Figure 6. Crew members systematically assess architectural systems (Helmer, 2017)



Figure 7. Tools and materials stored on site that could be helpful for a future project



Figure 8. Photos of specific damage versus typical conditions



Figure 9. Lookout locked and shuttered at end of assessment (John Millikin, 2017)



Figure 1. Complete toolkit and day-pack supplies at Bull of the Woods Lookout.

APPENDIX C:

ASSESSMENT TOOLS

Measuring Tools

- 25' tape measure or laser device
- torpedo level
- plumb bob

Investigative Tools

- small folding knife with 3" blade
- small screwdriver with changeable bits
- awl with 4" point
- small telescopic mirror
- headlamp

Safety Equipment

- latex-coated cloth work gloves
- dust mask or kerchief
- backcountry first aid kit
- Spot device or Forest Service radio
- topographic map

Record-Keeping Equipment

- digital camera and/or smartphone
- spare batteries and/or solar charger
- clipboard with compartment
- notepad with graph paper
- pocket notebook with ruled paper
- pens

Optional Tools

- 50' tape measure for large structures
- rake to expose foundations
- sandwich bags for mortar samples
- hardhat for hazardous structures
- led paint test kit

Personal Hiking & Camping Equipment

- water treatment, hiking poles, etc.
- tent, cook-kit, fuel, meals, etc.

APPENDIX D:
ASSESSMENT REPORTS

Bull of the Woods Lookout

Bull of the Woods Wilderness, Mount Hood National Forest

Charlotte Helmer, HistoriCorps Principal Investigator

December 2017



Summary

Bull of the Woods Lookout is located in the Clackamas River Ranger District of the Mount Hood National Forest and is accessed from the Bull of the Woods Trailhead, 45 miles from the district office in Estacada, Oregon. From Bull of the Woods Trailhead the lookout can be reached by Bull of the Woods Trail (#550) which rises from an elevation of 4540' at the trailhead to 5520' at the lookout over 3.3 miles of trail. The lookout's coordinates are approximately 44.8848, -122.0958.

The lookout is a single story building on top of a wood tower. The cab has a footprint of 14' x 14' and is of stud framed construction, clad in horizontal shiplap boards, with a hipped roof clad in shingles. The lookout's most distinctive features are its continuous windows, catwalk, and awning shutters across all four elevations. A single door with windows is offset in the east elevation. Bull of the Woods Lookout was constructed in 1942 and is demonstrative of the "Standard 1936" variation which features a hipped roof and extended ceiling joists that support the shutters.

As of its assessment in 2017 Bull of the Woods Lookout is in fair condition and retains a high degree of integrity in all seven of the characteristics that are typically considered: setting, location, craftsmanship, design, materials, feeling, and association. The lookout's foundation and structure are in excellent condition which preserves the opportunity to restore this building without a substantial reconstruction. Preservation projects could be completed by a small group of experienced preservation carpenters or volunteers supervised by experienced project managers. Although the lookout has no recreational use, it is unsecured and frequently used by the public.

All proposed actions are dependent upon the forest's management decisions and the MRDG process.



Bull of the Woods Peak during a solar eclipse, July 2017

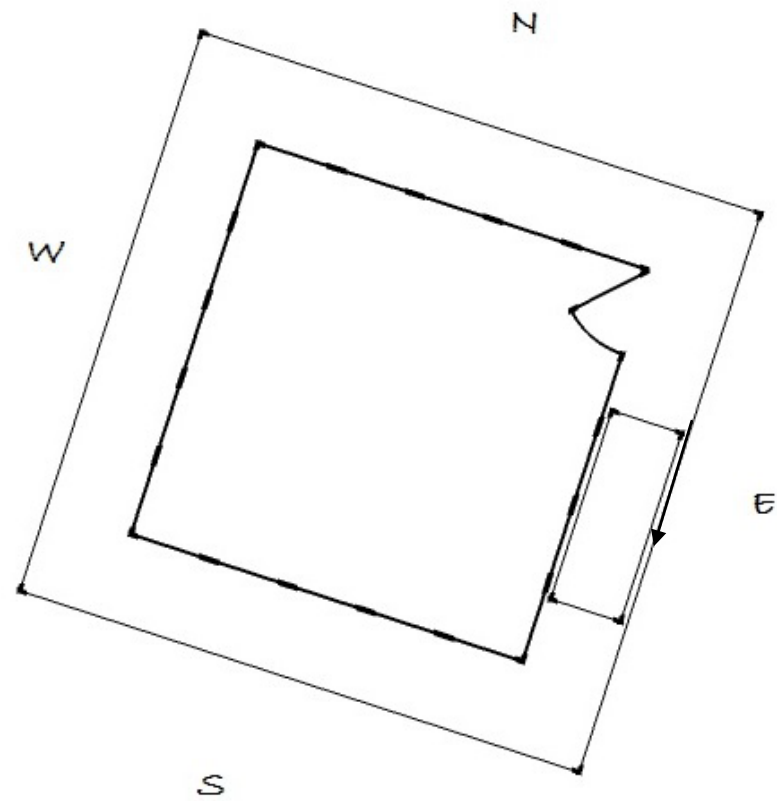

BULL OF THE WOODS LOOKOUT

0' 1' 5'

Site

Bull of the Woods Lookout is sited on a peak with ridges that extend to the north, southeast, and southwest. From this vantage point, the lookout offers a 360-degree view with Mount Hood to the north, and Mount Jefferson and the Three Sisters to the south. The Bull of the Woods Trail approaches the lookout from the north and passes by on its west side. It switchbacks down the south side of the peak to connect with the Motherlode Trail. A fire pit is located near the lookout. A detached latrine is sited about 50 yards south of the lookout. Neither appear to be significant historical features. A small flat camping spot is on the south side of the peak, just above the tree line. Overall, the site is in good condition; common concerns such as overhanging branches, erosion, and duff are not present. The site provides excellent drainage and ventilation for the lookout. Exposure is significant but not extreme and it primarily affects the southeast side of the building.

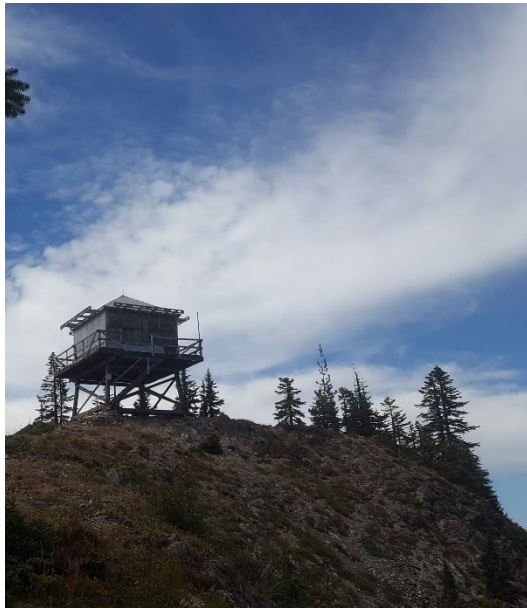

Bull of the Woods Peak



Stone steps



Latrine

Exterior

Tower - The lookout cab stands on top of a pressure treated wooden tower approximately 12’ high that is in good condition. Concrete footings support the four legs. Each footing is chipped and cracked at the corners, but these signs of weathering do not indicate significant structural issues. The tower legs are constructed from four sistered 2x8s and are cross braced with 2x10s. The cab’s floor joists and catwalk deck are supported by a pair of beams also constructed from sistered 2x10s.

Stairs - A single flight of pressure treated steps leads to the catwalk and the door, located on the east elevation. These stairs may be original, or at least closely resemble the original design. They are in fair-to-poor condition. The railing is sound. A short flight of dry laid stone steps leads to the first wooden tread and is in poor condition. It may have been dismantled for fire rings or stone cairns.

Recommended treatment: replace the stair treads and reinforce them with hardware installed on the undersides where it is mostly out of site. The stone steps could be repaired with stones that are already located on site.



Tower and floor structure



Stairs

Catwalk - The catwalk surrounds the lookout cab on all four elevations and is in fair-to-poor condition. The joists are in excellent condition, but the deck and railings pose a safety hazard and will reduce the building's integrity if they deteriorate. Railings are constructed with posts, diagonal braces at each corner, and two horizontal rails reinforced with a continuous panel of wire fence. All pieces of the railing are in place but posts and rails are weathered and rotted; wire panels are rusted, bent, and torn; and the rickety railing has been reinforced with 2x4s. The catwalk deck has been repaired in the past with boards in several different sizes. The original deck boards appear to be 3½" x 1¼". They run east-west, so boards on the north and south elevations are long and boards on the east and west elevations are short. The south and east sides are the most deteriorated. *Recommended treatment:* repair the railing by replacing one central post on each elevation, all railings, and the wire panel that wraps across the exterior of the railings. The deck could be repaired by replacing all long deck boards and then reusing salvaged materials to replace short boards on the east and west sides as needed.



Railing condition



Deck condition, south side



Deck condition, east side

Walls - Each elevation is clad in four rows of horizontal shiplap siding over horizontal sheathing below a row of windows. The siding is in fair condition due to weathering. Boards are cracked and worn, but most do not need to be replaced yet. The sheathing underneath appears to be in good condition, except at the southwest corner where it has been exposed to the weather and it rotting. A 1” gap has opened at the southwest corner, and it is not possible to identify the source of this issue without removing some original siding. *Recommended treatment:* investigate damage located at the southwest corner, and remove some original siding to access and repair the sheathing underneath. It will be particularly important to identify potential water damage to the sheathing and framing underneath. It may be necessary to replace at least two 6’ long boards of broken siding on the west side and to anticipate some additional breakage when the sheathing is repaired.



Typical wall condition

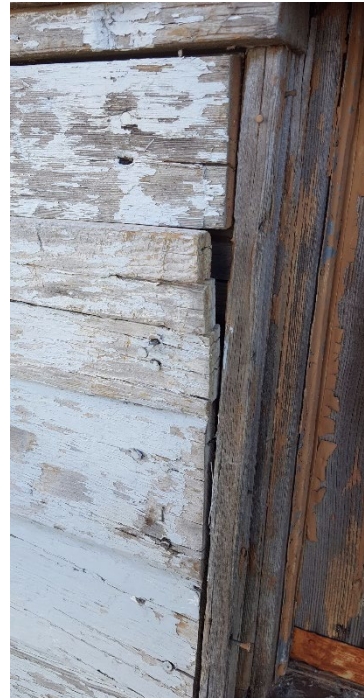

Typical siding condition

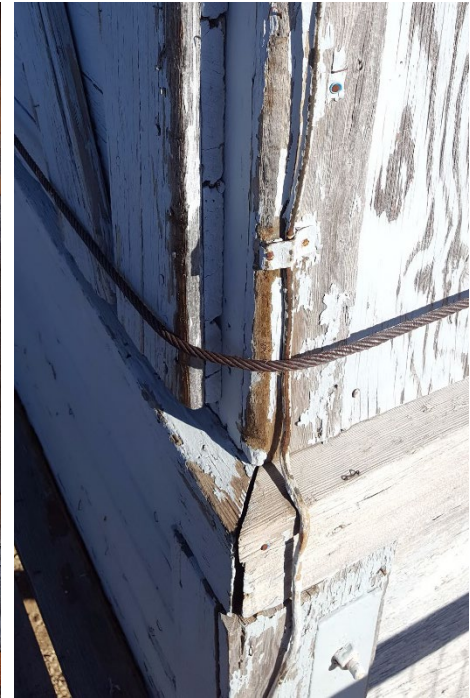

Typical trim condition

Exterior trim - Each elevation is trimmed with corner boards below the windows, corner boards alongside the windows, window sills, window aprons, headers that support the shutters from above, and small pieces of horizontal trim that fits between the extended rafters like a rake. Overall, the trim is in fair condition. Most of the damage is concentrated on the southeast side of the building where weathering and exposure are the most severe and on the southwest corner where the walls are misaligned. The corner boards are in poor condition, typically cracked, weathered, broken, or missing. A window sill at the southwest corner is loose. *Recommended treatment:* replace corner boards throughout and reinstall loose window sill which is located near the southwest corner.

Exterior finishes - The lookout was previously treated with a light grey latex-based paint. Weathering, UV damage, and exposure have stripped almost all paint from the exterior, particularly on the southeast side. The lookout was also previously wrapped to preserve it from forest fires, and is now riddled with large rusting staples. *Recommended treatment:* remove staples from the exterior, test for lead, scrape surfaces, and apply primer and paint throughout.



Condition at the southwest corner

Shutters - The shutter system is in fair condition. Each elevation has two awning-style shutters constructed from a single layer of 1x6 horizontal tongue and groove boards reinforced with vertical and diagonal braces. The shutters are designed to hang suspended from rafters above. All shutters on the south and east sides are severely weathered and broken. Shutters on the north and west sides are slightly weathered and the boards are sporadically cracked or missing. Some have been replaced in the past with a slightly different design. The shutter hinges and pins are in good condition. At least four pins and six hinges are missing. *Recommended treatment:* reconstruct four shutters and repair four shutters; replace absent hardware.



Typical condition, north elevation



Typical condition, east elevation



Construction and hardware

Windows - Overall, the window system is in poor condition. These elements are highly significant architectural features that define the lookout's historical character and function. They also serve a critical structural purpose by protecting the interior, walls, floor, and foundation from weather damage and keep the building secured. Bull of the Woods Lookout originally had 19 four-lite casement windows, but all sash on the south and west windows have been removed. They are not stored on site. These window openings are covered by sheets of plywood. A sash on the north elevation was replaced with a reconstruction that does not match the originals (although it bears a close resemblance). The remaining sash are missing 4 panes of glass. A substantial amount of glazing putty is damaged. All interior stops are in place. All exterior stops are in place or stored under the bed, ready for new windows to be installed. *Recommended treatment:* reinstall or rebuild ten absent sash, repair extant sash by replacing missing glass panes and reglazing with new putty.

Door - The lookout's single door is on the east elevation, at the top of the stairs. It appears to be original and is in poor condition. The glass panes, muntin, and hardware are worn but intact, however, the bottom of the door is broken as if it has been kicked open and repaired numerous times. The door does not lock. *Recommended treatment:* repair or replace the door (this may require further, more detailed assessment).



Window condition



Door construction



Door condition

Outriggers - Shutters are held open in an awning position suspended from outriggers that protrude above the windows. All these outriggers appear to be in good condition, weathered but not cracked or broken. All hardware is in place.

Roof cladding - The hipped roof was not fully accessible during this assessment but appears to be in fair condition. Internal rafters and sheathing were partly visible through the attic hatch, and they appear to be in good condition. The attic is uncluttered and well ventilated. Stove pipe hole has been closed up. Light is visible through the sheathing boards, which indicates that the roof has no moisture barrier, or the barrier is failing. Three sides are clad in cedar shingles that are weathering but in good condition. The east side of the roof has been redone in rolled asphalt with wooden battens, which is a functional alteration to the original design. The hips and peak are capped with metal which is in good condition, but a 1' long section is missing on the southwest corner. *Recommended treatment:* replace the east side of the roof with cedar shingles once the asphalt layer begins to fail, and replace flashing that is absent from the hip.



Outriggers



Asphalt roof



Shingled roof and flashed hip

Interior

Floor - The subfloor is visible from below the tower and it appears to be in excellent condition. The floor is clad with 3¼” wide tongue and groove boards, and in fair condition. Most boards are worn but intact. A section of boards is missing in the southeast corner.

Recommended treatment: replace absent floorboards.

Walls - The wall cladding and trim are in good condition overall. The walls are clad in four rows of lapped boards that match the exterior siding and are all intact. Quarter-round trim surrounds the floor and ceiling. An 8’ section of quarter-round trim is missing near the door. Window sills, headers, and mullions are all in good condition. *Recommended treatment:* replace absent trim.

Ceiling - The ceiling is clad in the same lapped boards as the walls. All boards are in place.

Interior finishes - The interior was previously treated with latex-based paint. The floor was finished with grey-over-white which is now in poor condition. The walls and ceiling were finished with white-over- green, which is in fair condition. *Recommended treatment:* test for lead content, scrape failing paint, and apply primer and paint.



Floor condition



Ceiling condition

Additional Features

Furniture - The lookout contains a desk, two cabinets, and second desk with the legs cut short, and a fire finder cabinet. The desk is in fair condition. The cabinets are in poor condition. These may be original features of the interior but are not as significant as other furniture, such as an original Osborn Fire finder would be. *Recommended treatment:* repair and retain furniture.

Onsite Tools and Materials - The lookout contains approximately 10 bundles of cedar shingles in good condition, a 10' folding ladder, a locked toolbox, shovels, a level, various fasteners, two sawhorses, water reservoirs, a broom, a 5 gal bucket, a rock bar, roofing harnesses, a rip saw, an axe, loppers, a post hole-digger, an herbicide sprayer, 1/3 gallons of paint thinner, 1-1/3 gallons of linseed oil, 5 ounces of glass cleaner, 48 ounces of bleach, and several tarps.

Security - The lookout is secured with a griphoist and cable that have damaged the corners. Otherwise, the griphoist system is a reasonable intervention that allows people to enter to lookout. *Recommended treatment:* install a small amount of metal flashing at corners to protect them from further scarring.

Safety - The lookout is not safe for visitors but its hazards it does not pose any hidden structural concerns. The catwalk boards and railings are minimally strong enough to support a person walking around the outside and would likely break if someone fell into the railing. Rodent droppings and trash inside the lookout create a potential harm from Hantavirus and tetanus. A fire extinguisher is in place and dated 2014. *Recommended treatment:* update fire extinguisher, repair the catwalk, and remove debris inside the lookout.

Summary of Work Items

SYSTEM	CONDITION	URGENCY	TASKS
safety	poor	critical	Repair catwalk railing; replace fire extinguisher
catwalk	poor	critical	Replace deck boards: fourteen 10' long 3½" x 1¼" boards, salvage original long boards and cut down to 9" or 3' long as needed. Replace posts: four 4' long, 4x4s with a 2" x 2½" notch at top. Replace railings: sixteen 10' long 1¾" x 3¼" boards. Replace wire panels: 80' roll of 3' tall wire with 2x4 squares.
finishes	poor	urgent	Remove staples, test for lead, scrape, prime, and paint two coats (4 gallons of each).
shutters	poor	urgent	Repair 4 shutters: nine 7' long ¾" x 5½" tongue and groove boards, seven 5'3" long 1x6s, one 8' long 1x6. Rebuild 4 shutters: 44 7' long ¾" x 5½" tongue and groove boards, eight 5'3" long 1x6s, four 8' long 1x6s. Replace 4 pins and 6 hinges.
windows	poor	urgent	Replace missing windows: ten 31"x 60" x 1¼" sash with 1" wide muntins, 2" wide side rails and top rail, 3" wide bottom rails. Replace glass: forty 2'3¼" x 1'1¼" panes.
roof	poor	urgent	Replace east side roof with cedar shingles (1 square of shingles). Repair hip: 1" x 6" flashing.
stairs	fair	urgent	Replace treads: twelve 1'10"x1½"x5¼" pressure treated boards. Rebuild stone steps.
walls	fair	urgent	Investigate failure at the southwest corner and monitor or repair. Repair sheathing: three 4' long 1x8s. Repair siding: four 6' long 1x5 shiplap boards.
trim	fair	urgent	Replace corner boards: four 5' long 1x4s, four 5' long 1x3s, one 2' long 1x4, one 2' long 1x3. Reinstall window sill. Flash corners where griphoist-cable is scarring. Repair interior trim: 8' long piece 1" thick quarter-round trim.
door	fair	minor	Repair or replace with similar door
floor	fair	minor	Repair: six 6' long ¾" wide tongue and groove boards

Proposed Access

Roads

Bull of the Woods Lookout is located in the Clackamas River Ranger District of the Mount Hood National Forest and is accessed from the Bull of the Woods Trailhead. Bull of the Woods Trailhead can be reached by driving 45 miles from the district office in Estacada, Oregon. From Estacada, the route follows OR-224-E, Clackamas River Highway (Forest Road 46), Collowash Road (Forest Road 63), and Forest Road 6340. Roads are well maintained and signage is scant but accurate all the way to Bull of the Woods Trailhead. The trailhead offers room for dozens of cars and easily accommodates a trailer.

Trails

From Bull of the Woods Trailhead the lookout can be reached by Bull of the Woods Trail (#550) which rises from an elevation of 4540' at the trailhead to 5520' at the lookout over 3.3 miles of trail. The lookout's coordinates are approximately 44.8848, -122.0958. The route has no reliable water sources, expect perhaps a seasonal slough located within the first mile of the trail. Water could be retrieved from either Big Slide Lake to the east or Dickey Lake to the west. Small camping sites are scattered all along the trail. The lookout is on a flat ridge where as many as 8 crew members could work effectively at one time.

Route to Bull of the Woods Trailhead. Google Maps.

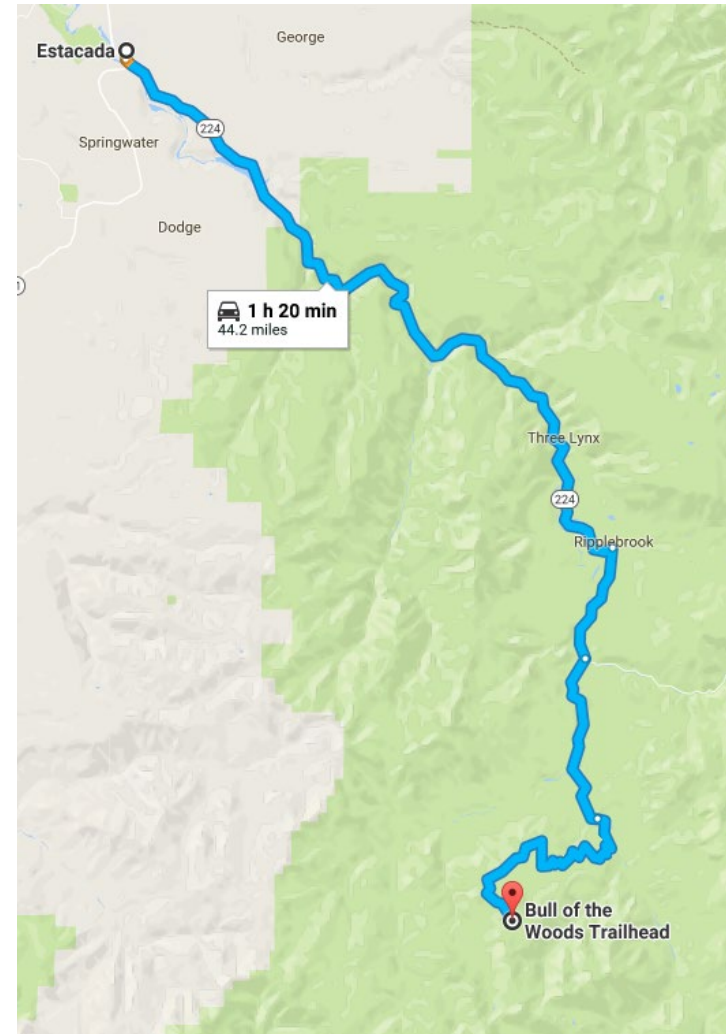

Staging Materials

The recommended method for future work at Bull of the Woods Lookout would be a) a pack train from the Bull of the Woods Trailhead or b) helicopter flights from an unidentified staging area to a flat area on the ridge east of the lookout.

Stock - The trailhead provides room for a horse trailer. The last section of the trail may be too steep and narrow to reasonably travel with a heavy-laden pack train. However, a stock trail could reach the lookout via the Pansy Creek Trailhead and Pansy Creek Trail (#551) and Motherlode Trail (#558). This route is longer, but less steep. The ridge around Bull of the Woods Lookout provides ample space to string up a high-line, unpack the train, and/or turn the train around. Water sources near the lookout may be insufficient. Wilderness regulations permit travel and dispersed camping so long as the party (stock and people) is no more than 12.

Helicopters - Staging areas were not identified during this assessment, but several clearings and parking areas along Forest Road 6340 could provide enough room, such as a quarry or slide located at 44.9312, -122.1127. Bull of the Woods Trailhead may also be a feasible staging area.

Trails to Bull of the Woods Lookout. www.naturalatlas.com.

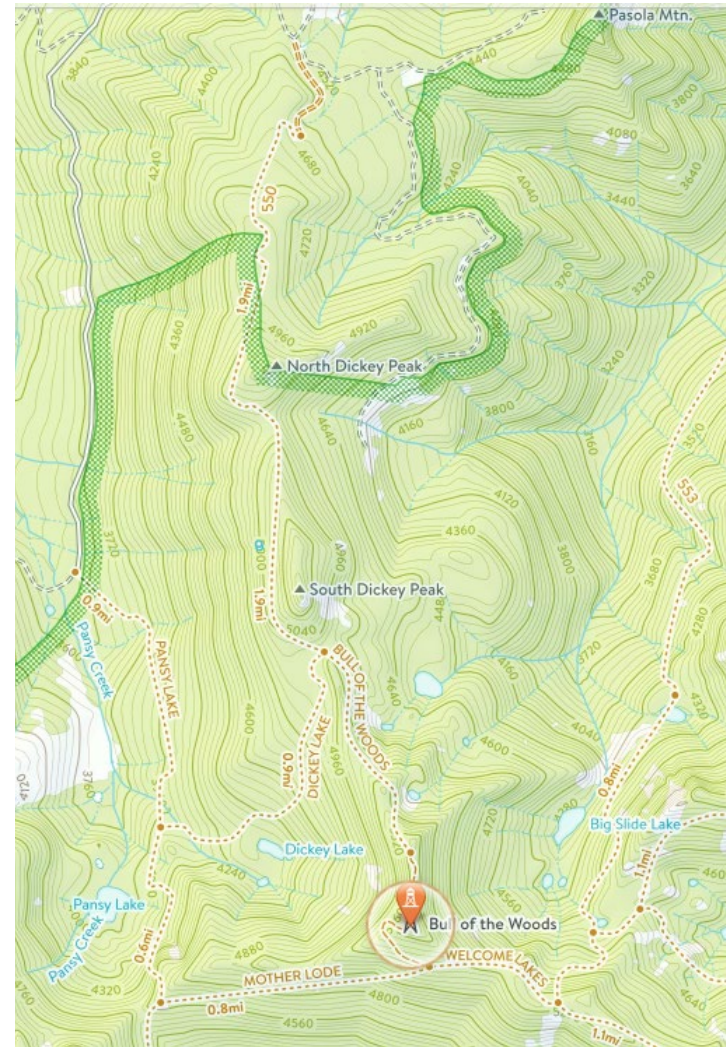

Devil's Peak Lookout

Salmon-Huckleberry Wilderness, Mount Hood National Forest

Charlotte Helmer, HistoriCorps Principal Investigator

December 2017



Summary

Devil's Peak Lookout is located in the Zigzag Ranger District of the Mount Hood National Forest and is accessed from either the Cool Creek Trailhead or the Kinzel Lake Trailhead which are 13 or 25 miles (respectively) from the district office in Zigzag, Oregon. The lookout can be reached by Hunchback Trail #793 from the south or Cool Creek Trail #794 from the north. It is sited at 4900' and its coordinates are approximately 45.264159, -121.875655.

The lookout is a single story building on top of a wood tower and concrete piers. The cab has a footprint of 14' x 14' and is of stud framed construction, clad in shiplap boards, and has a hipped roof clad in cedar shingles. The lookout's most distinctive features are its continuous windows, catwalk, and awning shutters across all four elevations. A single door with windows is offset in east elevation. Devil's Peak Lookout was constructed in 1933 and is demonstrative of the second generation of L-4 lookouts which introduced a hipped roof instead of a front-gable roof. It was originally a ground cab; the tower was added in 1952.

As of its assessment in July, 2017 Devil's Peak Lookout is in fair condition and retains a high degree of integrity in all seven of the characteristics that are typically considered: setting, location, craftsmanship, design, materials, feeling, and association. The lookout's foundation and tower are in good condition, which preserves the opportunity to restore this building without a substantial reconstruction. The only structural concern is an expanding gap between the south and west walls, which requires further investigation. Its physical condition is a testament to decades of maintenance by the Forest Service as well as ad-hoc, improvised repairs made by visitors. This legacy of creative maintenance is not ideal for a historic structure, but it does indicate that the lookout has a cultural significance that extends into the present day. The forest has an opportunity to harness public support for a thoughtful restoration of this building.

All proposed actions are dependent upon the forest's management decisions and the MRDG process.

Devil's Peak Lookout, 1984. USFS.



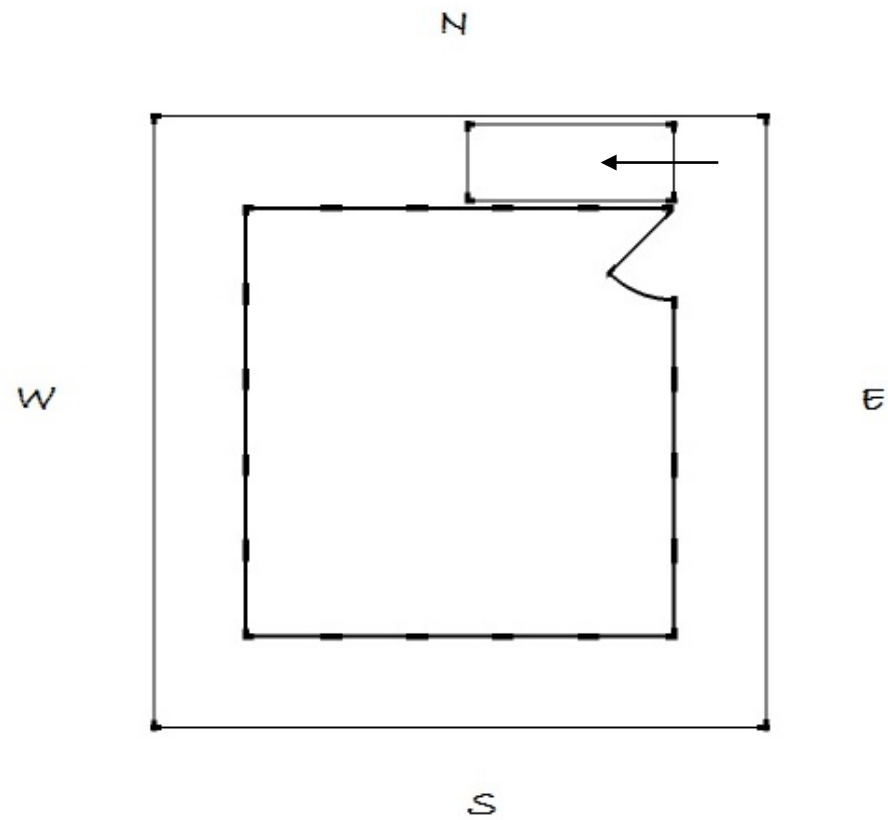

DEVIL'S PEAK LOOKOUT

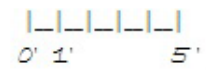

Site

Devil’s Peak Lookout is sited on a solid base of rock with steep slopes descending to the east, south, and southwest. Overall, the site is in good condition; common concerns such as overhanging branches, water runoff, erosion, and duff are not an issue. The site provides excellent drainage and ventilation for the lookout. Historical viewsheds are intact. Exposure is significant but not extreme and it primarily affects the southeast side of the building.

An 8’3” by 8’4” front gable storage shed is located directly beneath the lookout cab. It has a log footing and is clad in the same shiplap siding used on the lookout. The shed door faces south and is unlocked. A single window is located on the north elevation. The shed is in good condition but occupied by animals that have damaged the gear stored inside. A wood box located at the shed’s north elevation is in poor condition. It is probably not original but it serves a useful purpose. The lid has broken and is covered with a tarp. The sides were previously wrapped in wire to keep animal out. *Recommended Treatment:* clean out the shed and secure holes that have allowed animals inside. Repair the wood box with three 4’ long 1x5 tongue and groove boards and re-secure the wire wrapping.



Wood box and shed



Shed interior, animal activity

Exterior

Tower - The lookout cab stands on top of a 10' high wooden tower, added in 1952, that is still in good condition. Concrete footings support four legs. Each footing is chipped and cracked at the corners, but these signs of weathering do not indicate more significant structural issues. The tower legs are constructed from four sistered 2x8s and are cross braced with 2x10s. The cab's floor joists and catwalk deck are supported by a pair of beams also constructed from sistered 2x10s.

Stairs - A single flight of pressure treated steps leads to the catwalk and the door, located on the east elevation. These stairs are not original but they align with the original first tread and the landing. The stairs are in good condition.

Floor Structure - The subfloor is visible from below the tower and it appears to be in excellent condition.

Catwalk - The catwalk deck and railing are in good condition.



Typical construction and condition of footing, tower, floor structure, and catwalk

Walls - The siding is in fair condition. Each elevation is clad in five rows of horizontal 1x5 shiplap siding over horizontal sheathing. Weathering has damaged boards on the north, east, and south elevations. The west elevation is in good condition. The first (lowest) row of siding was damaged when flashing was installed at the edge of the cab. A 3” gap has opened at the southwest corner, and it is not possible to identify to source of this issue without removing some original siding. *Recommended Treatment:* repair the lowest row of siding by replacing three 6’ pieces and one 8’ piece of shiplap. Remove siding at the southwest corner so that the structural problem can be investigated. It will be particularly important to identify potential water damage to the sheathing and framing underneath. The footings may have shifted and pulled the cab walls out of alignment; check to see if the foundation and cab are level.

Exterior trim - Each elevation is trimmed with corner boards, window sills and aprons, horizontal boards that support the shutters from above the windows, and molding at the top of each wall. Overall, the trim is in fair condition. *Recommended Treatment:* replace six corner boards below the windows, two headers, and several small sections of molding.



Separation of the south and west walls

Exterior finishes - The lookout was previously treated with latex-based paint in light grey over most of the exterior and light green on siding below the windows. Almost all paint from the exterior has now failed, particularly on the southeast side. *Recommended Treatment:* test for lead content, scrape all exterior surfaces, and apply two coats of primer and paint to match the color scheme.

Shutters - The shutter system is in fair-to-poor condition. Each elevation has two awning-style shutters constructed from a single layer of 1" thick horizontal tongue and groove boards reinforced with vertical and diagonal braces. The shutter parts were originally nailed together and painted white. The shutters hang by long strap hinges and are held open by short struts that rest on the catwalk railing. All shutters are 4'-8" tall. Most are 7' wide, but two shutters that share the same elevation as the door are narrower, at 5'-5" wide. The door may have had its own 2'-10" wide shutter at one time. The shutters are built from horizontal 1x6 tongue-and-groove boards and are braced with vertical and diagonal 1x6 boards. Shutters on the south side of the building were previously reconstructed and are in good condition. Struts are in fair condition, worn but functional. *Recommended Treatment:* reconstruct two large shutters and both small shutters; use salvaged pieces to repair missing and damaged part of the other shutters. All the existing hinges (a mix of originals and replacements) can be reused.

Windows - Overall, the window system is in fair-to-poor condition. These elements are highly significant architectural features that define the lookout's historical character and function. They also serve a critical structural purpose by protecting the interior, walls, floor, and foundation from weather damage and keep the building secured. Devil's Peak Lookout has 19 four-lite casement windows. Three elevations have five windows and the north elevation has four. All are designed to open by rotating on a horizontal hinge so that the top of the sash swings in and the bottom swings out. Windows are held open by stops hinged to the ceiling. All sash, muntins, mullions, and sills are in good condition. All exterior side stops are in place, but three interior stops are missing. Window sills have been punctured by holes that were probably part of a system for locking the shutters. The shutters no longer need to be secured so the holes can be filled and the sills primed and painted. Most glazing putty is missing or damaged or damaged with unsympathetic and ineffective materials such as caulk. Many of the glass panes have been replaced with plexiglass, which is a reasonable alteration except that plexiglass panes located near the wood stove have warped from the stove's heat. 11 glass panes are broken or cracked. All hinges, ceiling stops, and brass keeps are in place. Three brass catches are. *Recommended Treatment:* Replace interior stops with 2'-10" long 1" x 1/2" battens; replace broken panes and reglaze all sashes; replace missing hardware.



Condition of north shutters



Condition of the west shutters



Condition of south shutters



Condition of east shutters



Typical window construction



Ceiling stops



Typical condition, hardware



Typical condition, window sills



Typical condition, sash and glazing

Door - The lookout's single door is on the east elevation. It appears to be original and is in critical condition. Every feature has been altered with a series of make-shift repairs that are not holding up. The door is sagging on its hinges, scraping against the floor. It's delicate molded details have been broken, caulked, patched, and re-broken numerous times. It may be possible to salvage the side rails, lower panels, and hardware. *Recommended Treatment:* replace the door with a reconstruction that matches the original. This may require a more detailed assessment unless as-built drawings are already available.

Roof - The hipped roof appears to be in good condition. It is clad in cedar shingles and capped with metal at the hips and peak. The attic was inaccessible during this trip but rafters and sheathing were partly visible through the attic hatch. The roof structure appears to be in good condition. The attic appears to be uncluttered (except for tools) and well ventilated. *Recommended Treatment:* tidy the attic and remove excess supplies and trash.



Typical condition, door



Typical condition, roof



Typical condition, attic

Interior

Floor - The floorboards are in fair condition except for a section of the southwest corner which has been repaired with unpainted, mismatched boards and covered by a sheet of plywood. The remaining floorboards are worn but intact. *Recommended Treatment:* repair the floor damage with four 4' long boards of 3/4" x 3 1/4" tongue and groove.

Walls and trim - The wall structure, cladding, and trim are in fair condition. Walls are clad in seven rows of horizontal tongue and groove boards, all intact. Woodwork in the southwest corner has been affected by the expanding split between the south and west walls but cannot be repaired until the structural issue is addressed. 1" quarter-round trim around the floor and ceiling requires some repairs. *Recommended Treatment:* replace a 6' section and a 2' section of trim around the floor.

Ceiling - The ceiling is in good condition and is clad in in the same tongue and groove boards as the walls. No repairs are needed.

Interior finishes - All the interior finishes are in fair or poor condition. They have been stained by smoke, worn, and weathered. The failing paint indicated that several color campaigns have been used over the years. The floor paint is a light green over white, the walls and ceiling are painted white over light green and dark green, the trim is consistently dark green, and the window sash are painted white over dark green. *Recommended Treatment:* test for lead content; then clean, scrape, prime, and paint all surfaces. Further research is needed to identify the original Depression-era paint campaign that the Forest Service would have used. It may be appropriate to choose an all-white interior with a light green floor and dark green trim.



Typical condition of floor, walls, trim, and ceiling finishes

Additional Features

Appliances - The lookout's only mechanical system is a wood stove. There are no artificial lighting, ventilation, plumbing, or fire suppression systems. A lighting rod and four grounding wires are installed on the roof. The wood stove was not tested during this assessment, but it is severely rusted and held together by metal straps. *Recommended Treatment:* remove the stove.

Furniture - The lookout contains two beds, folding chairs, a short cabinet, two desks, an upright cabinet, and a toolbox. Some of these items may be original, such as the desks and the upright cabinet which would have held an Osborn fire finder. *Recommended Treatment:* a substantial restoration of the lookout's interior could include repairing and repainting the furniture.

Onsite Tools and Materials - Supplies are stored inside the shed, below the lookout, and inside it. These could be used in small repairs or to augment supplies for a restoration project but are not a significant source of materials. Supplies include 3 sleeping bags, a substantial tools cache, a ladder, tarps, and a 6' long 2x4.

Security and Safety - The building is not secured against animals or trespassers, but it has been adopted by visitors and could remain unlocked. The lookout is safe for visitors, but fire is a concern. *Recommended Treatment:* provide a fire extinguisher and discourage visitors from lighting candles, burning incense, and using the current wood stove. The front door could be annotated with a sign that explains the lookout's significance, invites visitors to use it, and asks them to treat the building with respect.



Woodstove



Furniture

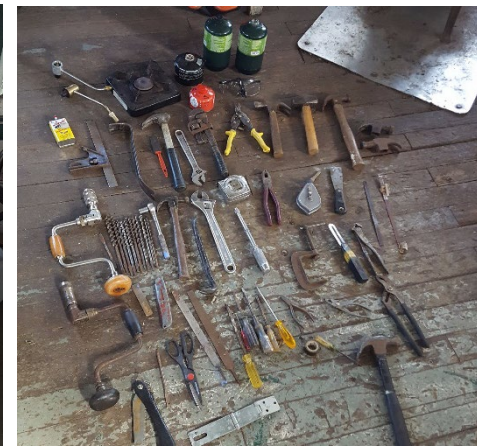

Tool cache

Summary of Work Items

SYSTEM	CONDITION	URGENCY	TASKS
walls	poor	critical	Monitor separation at the southwest corner to determine that it is stable or else identify the failure mechanism and repair.
door	poor	critical	Reconstruct original door, or replace with similar 30" x 76" 4 light wooden door
appliances	poor	critical	Remove wood stove; install fire extinguisher
shutters	poor	urgent	Reconstruct four shutters and repair others: eight 3' long 1x6s, eight 5' long 1x6s, four 8' long 1x6s, forty-four 7' long 1x6 TG boards.
finishes	poor	urgent	Repaint all interior and exterior surfaces. Test surfaces for lead, scrape, clean, patch woodwork, then prime and paint with two coats (5 gallons each).
windows	fair	critical	Replace panes: 20 1'x2' glass. Reglaze 19 sash. Replace interior stops: three 2'10" long ½" x 1" battens. Replace hardware: three brass catches.
siding	fair	urgent	Repair: five 6' long 1x5 tongue and groove (TG) boards
security/safety	fair	urgent	Install fire extinguisher, remove wood stove, discourage use of candles and incense
floor	fair	minor	Repair floorboards: four 4' long ½" x 3½" TG boards
trim	fair	minor	Replace corner boards: two 27" long 1x2s and four 27" long 1x4s. Replace headers: two 8' long 2x4s. Replace molding: three 2' long sections. Repair sills with wood epoxy. Replace interior trim: two 6' long 1" quarter round
site	good	minor	Remove trash from lookout and shed. Repair wood box: three 4' long 1x5 TG boards.

Proposed Access

Roads

Devil's Peak Lookout is located in the Zigzag Ranger District of the Mount Hood National Forest and is accessed from either the Cool Creek Trailhead or the Kinzel Lake Trailhead. Cool Creek Trailhead can be reached by driving 13 miles from Zigzag, Oregon. The route follows US-26-W and Still Creek Road (Forest Road 2612). Parking is on the shoulder of the road. Kinzel Lake Trailhead can be reached by driving 25 miles from Zigzag. The route follows US-26-W, Still Creek Campground Road (Forest Road 2650), E Chimney Rock Road, and Kinzel Lake/Sherar Burn Road (Forest Road 2613). Forest Road 2613 is a rough, narrow gravel road with turnouts that is not recommended for trailers. The trailhead can accommodate up to 5 vehicles and would be a tight turn for a truck and trailer.

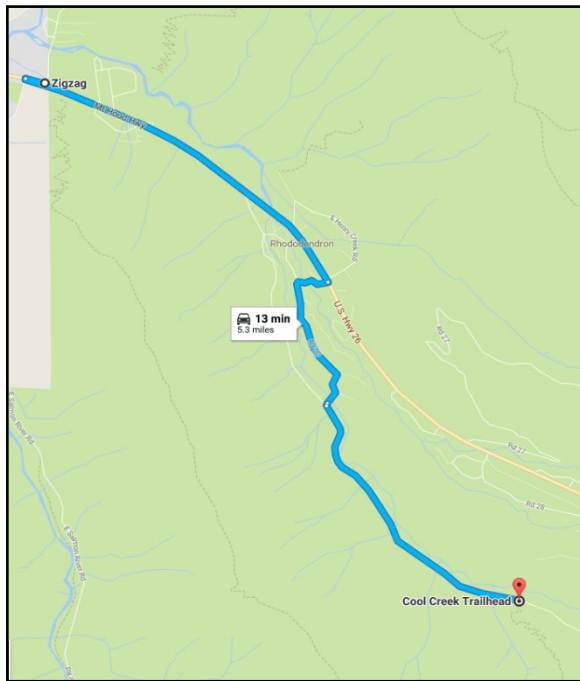

Routes from Zigzag to Cool Creek Trailhead.

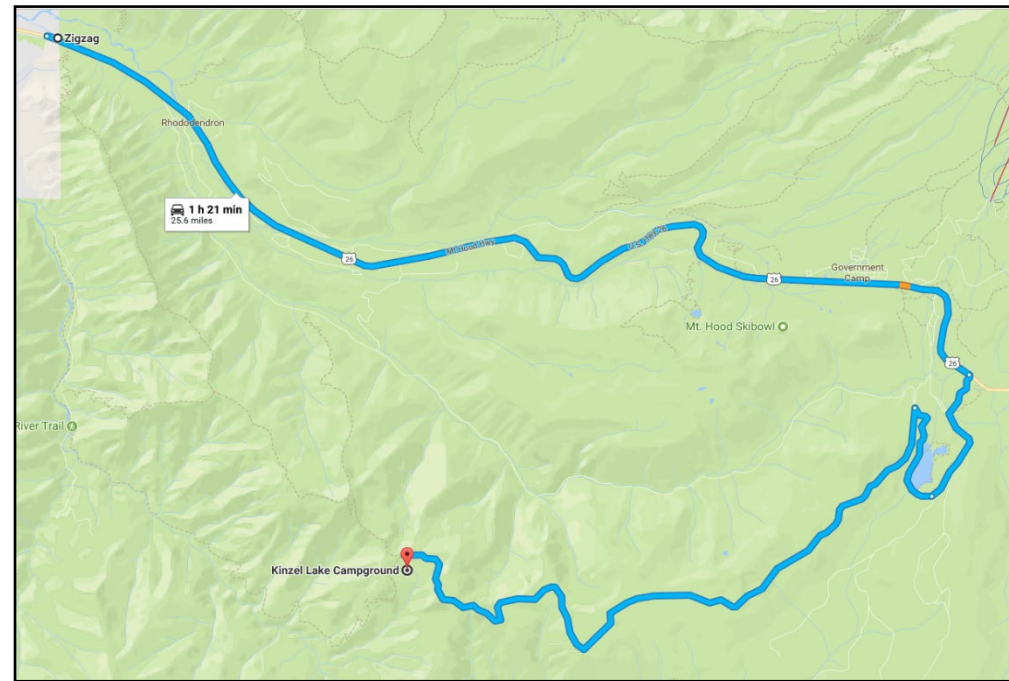

Route from Zigzag to Kinzel Lake Trailhead. Courtesy of Google Maps.

Trails

Devil's Peak Lookout can be reached by either Hunchback Trail #793 from the south or Cool Creek Trail #794 from the north. A short spur trail leads from the Hunchback Trail to the lookout. The lookout's coordinates are approximately 45.264159, -121.875655.

Hunchback Trail #793 climbs steeply from roughly 4480' to 4900' over 1.2 miles. The trail is narrow and rocky. Kinzel Lake provides a reliable water source near the trailhead, but there are no other water sources along the route. Cool Creek Trail #794 climbs steeply from 1900 to 4900 over 3 miles. The first two miles of the trail climb steadily while the last mile is more moderate. The lookout is on a steep site where no more than 6 crew members could work effectively at one time. Devil's Peak provides room for a couple of tents, and two additional people could camp inside the lookout. There is not water at the lookout.

Staging Materials

The recommended method for future work at Devil's Peak would be a) a pack train from the Cool Creek Trail or b) helicopter flights from an unidentified staging area on US-26 to an old helicopter pad located along the Cool Creek Trail within 1/8 mile of the lookout. The old landing site was not visited during this assessment but has been reported in previous assessments.

Considering the condition of roads and trails, the Cool Creek trail may be preferred for stock or a crew transporting supplies to the lookout. During an ongoing preservation project, the crew may prefer to camp at Kinzel Lake Campground and make a daily hike in along Hunchback Trail. The camp would ideally be established without using trailers.

First view of Devil's Peak Lookout from the spur trail



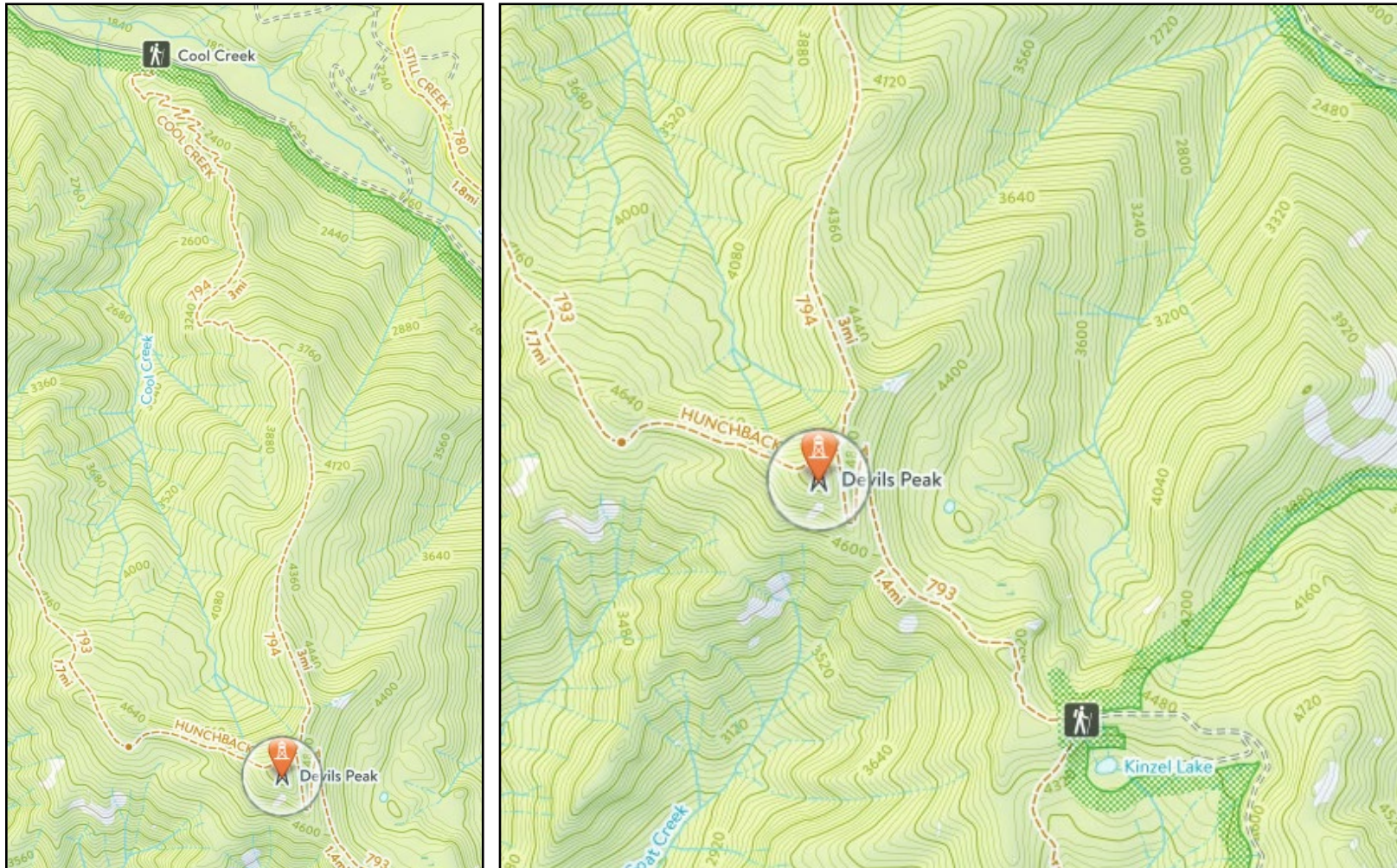

Maps of Hunchback Trail #793, Cool Creek Trail #794, and Devil's Peak Lookout. www.naturalatlas.com.

Kinzel Cabin

Badger Creek Wilderness, Mount Hood National Forest

Charlotte Helmer, HistoriCorps Principal Investigator

December 2017



0

Overview Assessment

The ruins of Kinzel Cabin are located in the Barlow Ranger District of the Mount Hood National Forest and is accessed from the Little Badger Trailhead, 25 miles from the district headquarters in Dufur, Oregon. The Little Badger Trailhead is located on Forest Road 2710 about 1 mile past the Little Badger Campground. Kinzel Cabin can be reached via Little Badger Trail (#469) which extends 3.5 miles along the north bank of Little Badger Creek and rises from 2160' at the trailhead to 3040' at the cabin. The cabin's coordinates are approximately 45.305385, -121.408897.

The ruins of Kinzel Cabin are sited on the north bank of Little Badger Creek on a small flat site at the base of a steep hill roughly 50 yards downstream from the shaft of Kinzel Mine. The cabin, which faced east towards the Little Badger Creek Trail, was originally a 16' x 24' single story building with a side-gable roof. The type of foundation that supported it is unknown; either the sill logs were always in direct contact with the ground or there was a rough stone foundation that became buried over time. Walls were built of unpeeled logs typically 6" - 9" in diameter and connected with half-lapped joints at the corners such that their ends extended roughly 1' beyond the joints. Logs were flattened on the top and bottom so that they fitted tightly and required minimal chinking. On the north and south walls, gable ends were clad in vertical board-and-batten siding made from 2x8 milled planks and thin strips of cedar bark. The roof was framed in poles and clad with nine courses of shakes on each gable.

A total of five windows were located on the east, west, and south walls where they were installed between the two bottom courses and two top courses of logs. The roughly 24' x 32" window openings were framed in short planks roughly 2" thick and 6" wide. It is likely that the windows were unglazed, or else they had wooden sash that were removed before the cabin was documented. At least one window opening was supported by short vertical poles nailed to the exterior of the wall logs. A doorway was located on the center of the east elevation and similarly framed in planks. It was also trimmed by two vertical planks nailed to the exterior of the wall logs. Inside, there was a single room with an open ceiling and a floor made from the same milled boards that covered the gable ends. No fireplace or chimney were ever built. A 1959 photo shows a small stove pipe that protruded through the roof near the ridge.

Today, the cabin is collapsed and deteriorated to such a degree that many of its architectural characteristics are obscured. The roof, which was broken by a fallen tree more than 40 years ago, is now entirely gone. The wall logs have rotted into the ground, but their dimensions and joinery are still partially evident. The north wall and its corners are less than 1' high. All log courses that comprise the south wall and its corners are still intact. The south wall's board-and-batten gable end has fallen into the center of the building. On the east elevation, the top plate log is still in place and indicates the original location of the cabin's only door. The plate is broken and suspended above the lower wall logs which have collapsed. Overall, the south end of the ruins still communicates useful information about how the cabin was constructed, but rest of the structure is unrecognizable.

By any measure, the ruin of Kinzel Cabin is now more than 50 years old and retains integrity of setting and location. However, all other characteristics are severely compromised. If the Kinzel Mine were considered to be a historically significant resource, the cabin ruins might be a contributing feature of the site but the mine has no known significance beyond a vague association with the history of resource extraction in this region of the Mount Hood National Forest. If heritage resource managers were adamant about preserving the remains of this mining site the south wall of Kinzel Cabin could be stabilized from the inside to retain some construction details such as the log joinery, window opening, and gable end-- but reconstruction is not recommended under any circumstances.

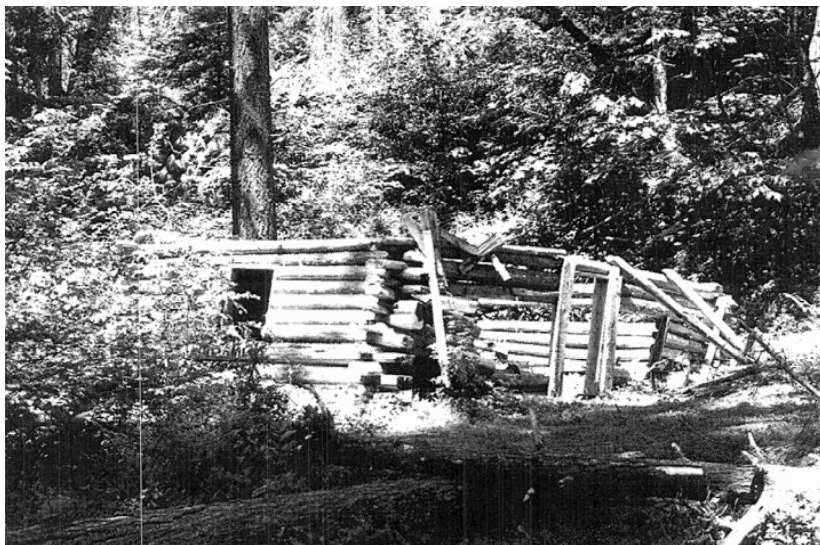

South and east elevations in 1997. Courtesy of USFS.



South and east elevations, 2017.



Log construction, south wall



Board and batten construction, south wall



Window construction, east wall



Doorway construction, west wall

Millard Ranger Station

Eagle Cap Wilderness, Wallowa-Whitman National Forest

Charlotte Helmer, HistoriCorps Principal Investigator

December 2017



Summary

The Millard Ranger Station was constructed ca. 1915 and is an example of early backcountry administrative infrastructure that was built by the Forest Service throughout the Northwest Region. It is also associated with the historic Red's Horse Ranch, although that connection is not well known. The Ranger Station stands at an elevation of approximately 3,600 feet near the Wild and Scenic Minam River. The site can be accessed by hiking approximately 7.5 miles from the Moss Springs Trailhead, east of Cove, Oregon.

The Ranger Station is a single-story, one-room log cabin on top of a short concrete foundation with a footprint of 12'6" x 23'4". The cabin's most distinctive features are its log-framed front porch, steep front-gable roof, and well-crafted log joinery. A single door is offset in the facade and small horizontal windows are located on the north and south walls. Although the ranger station was not built from a kit, like later forest service administrative structures, it nevertheless represents a building type that was used in backcountry locations throughout Region 6. The log construction, scale, and steep front gable roof are all standard features from this time period.

As of its assessment in late August, 2017 the Millard Ranger Station is in excellent condition and retains its administrative use. The cabin also retains a high degree of integrity in all seven of the characteristics that are typically considered: setting, location, craftsmanship, design, materials, feeling, and association. Continued cyclical maintenance will keep the building in good condition for decades to come. Previous preservation projects have sustained the building's physical integrity. The Ranger Station's present condition represents a success story, and demonstrates that the Wallowa-Whitman National Forest has skillfully preserved a historic resource that was incorporated within wilderness.

Millard Ranger Station, 1997. Library of Congress.

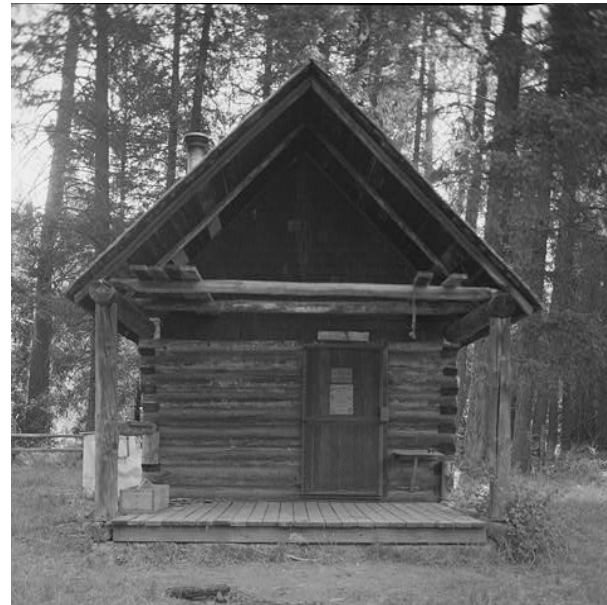

Site

Millard Ranger Station is sited in a wooded area between the southeast edge of a large meadow and the west bank of the Wild and Scenic Minam River. A spur trail leads from the meadow to the river and passes by the guard station on the south side. The building faces west. A large fire pit is located immediately in front of the building. Overall, the site is in good condition; common concerns such as overhanging branches, erosion, duff, and exposure are minor issues. Grade has risen against the north, east, and south sides of the building, such that the lowest wall logs are in contact with the dirt. Small plants are growing against the building on multiple sides. Plants and duff could be raked back to clear a 2' perimeter on every side of the building and uncover the foundation. It appears that a stovepipe on the north side of the roof's ridge was struck by a tree branch in the past. Two large storage boxes located at the east and north elevations could be moved further away from the building because they appear to be causing water damage to its walls. This is indicated by surface rot and biogrowth on the wall logs behind the boxes. The damage may be caused by snow collecting against the boxes and from rainwater splashing off the boxes. They are bear proof, steel-clad, ventilated, and secured with Master padlocks. *Recommended Treatment:* reduce grade to make sure that the building is at least 8" above grade; cut back overhanging branches; and relocate storage boxes.



Southwest corner and fire pit



Northeast corner and storage boxes



Plants against wall logs

Exterior

Foundation - The foundation is in fair condition. The building’s footprint is 12’6” x 23’4” (including the porch); The porch measures 12’6” x 7’4”. It is a 6” high wall built from concrete that has large aggregate and a rough texture. Moss indicates a moisture issue and could be removed from the foundation. An opening on the center of the south elevation provides limited access to the crawlspace underneath the building, and is filled with sticks and other debris. *Recommended Treatment:* clear out the crawlspace and secure it with a small wire panel to keep animals out.

Porch - The porch has been repaired in the past and is in good condition. The porch could use a single stone or pressure-treated step. Five pressure-treated joists run north-south and are certainly not original. It is likely that the porch floor was rebuilt more than a decade ago, and that the repairs have held up well. It is decked in 2x6 boards that are weathering at the ends, where they protrude beyond the roof’s eave. Four posts with valley notches at the either end are wedged between sill logs and log top plates. Top plates are connected by two pole rafter ties that run north-south. The top plates extend beyond the roof’s eave and are rotting from exposure. The southwest corner of the porch has been repaired with a small piece of pressure treated wood that lifts a rafter tie off of the top plate to protect it from rot. These minor structural issues and surface rot do not need to be addressed but could be monitored in the future. *Recommended Treatment:* install a step.



Porch construction



Foundation and sill construction



Condition at southwest corner

Sills - The sills are in good condition, despite a small amount of surface rot. The first course of sill logs are located on the north and south elevations. On the east wall, a gap below the bottom log course is covered by a thin log slice. This veneer is cosmetic and/or intended to block the crawlspace below. The north and south sills are each in two pieces connected with a lap and a butt joint at the seam between the cabin and the porch.

Walls logs - The walls are in good condition. Wall logs are typically 9” in diameter are tightly joined with half-laps at the corners. These joints are pinned together with vertical wooden pegs. Horizontal joints are stuffed with fibrous insulation and chinked with wooden battens that have a triangular profile. Six battens are missing or broken and could be replaced. All walls host light green/grey and yellow/red biogrowth, lichen, and moss. Wall logs near the northwest corner exhibit some surface rot that is probably caused by storage boxes that trap snow and reflect rainwater against the logs. The east wall is pock marked with insect holes, but there is no sawdust which indicates that the infestation might be inactive. Large checks have opened up in the logs on the east and south walls, but they do not have internal rot. Across each elevation, gaps are sealed with unsightly orange spray foam that has weathered and no longer retains its hard shell. The original fibrous packing/insulation is likely Oakum. *Recommended Treatment:* replace battens; confirm the daubing material and repack gaps with in-kind material; clean logs with a mild chemical treatment (ideally, not an abrasive treatment).

Wall shingles - The gable ends are clad in cedar shingles that have a 5” reveal. The west elevation is missing several shingles which could be replaced. Otherwise, the west end shingles are in good condition. They are coated with dust or smoke from the fire pit in front of the building. The east gable has some green biogrowth but no stains from dirt or smoke. *Recommended Treatment:* replace missing shingles and remove biogrowth with a mild chemical cleaner (not an abrasive method).



Wall construction details: joinery, chinking, shingles



Wall condition: biogrowth, surface rot, spray foam

Windows - Overall, the window system is in fair condition. Millard Ranger Station has two horizontal windows with four-light sliding sashes behind metal security cages. These windows are located at the center of the north and south elevations and measure roughly 6' x 2'4" (including the trim). The north window has a loose header that could be nailed down. The south window sill is split on both ends and could be replaced with a new 4'7" long 1x2 board. The glazing is in fair condition. One pane is cracked and patched with tape. All the glazing putty is skillfully applied but in poor condition. Sash would ideally be treated with several coats of linseed oil to restore the wood and extend the lifetime of new putty. Both security cages trap dirt and make it difficult to clean the windows. The window cages are bolted through the wall logs and should be easy to remove from the interior. *Recommended Treatment:* treat sash with linseed oil, replace cracked pane, reglaze all sash, and clean behind the security cages.



Window construction



Putty condition

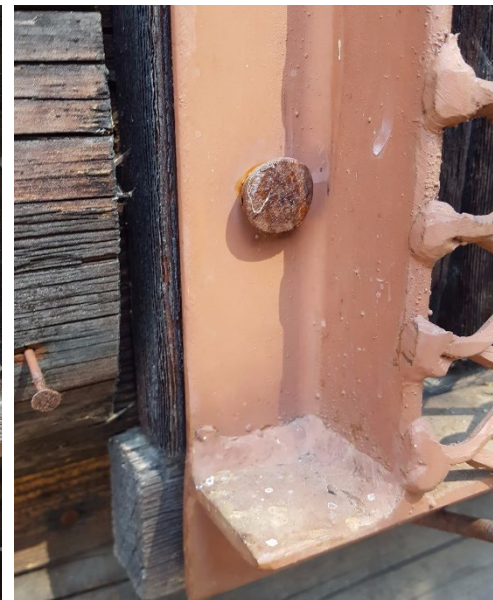

Security cage

Door - The front door was largely inaccessible during this assessment because it is covered in a metal security cage installed through the log walls. However, it appears to be in good condition. The metal cage is padlocked. The original door is latched with a strap, chain, and twisted nail. The handle is missing and has been replaced with a length of string for latch. *Recommended Treatment:* replace the handle with an appropriate replicate and retain the unique nail-latch.

Roof - The roof structure was only partially accessible during this assessment but appears to be in good condition. It a steep gable framed in poles and clad in a cedar shingles on top of wide sheathing boards. Rafter tails feature stains and surface rot but are all intact. One damaged tail has been ‘fixed’ with orange spray foam. This repair is sufficient as a temporary measure but could eventually be replaced with a spliced rafter tail. A stovepipe protrudes from the north side of the roof and appears to have been previously damaged and reinstalled.



*Door
stovepipe*



Door hardware



Roof structure

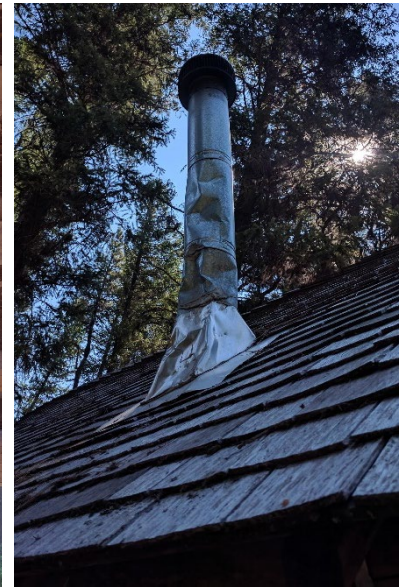

Roof cladding and

Interior & Operations

Millard Ranger Station’s interior was inaccessible but was inspected through the windows are appears to be in excellent condition. The floor, walls, trim, ceiling, and finishes are all well maintained. The cabin’s single room is clean and organized. It appears to be a well maintained and highly functional space. The cabin contains several appliances: an aluminum folding propane stove, propane lantern, and two propane canisters. No wood stove was evident, despite the stovepipe that is installed on the roof. Furniture includes several folding chairs, a garbage can, a counter or desk, two cabinets, and two sleeping cots. No fire extinguisher was evident, and it is critically important to have an operable extinguisher stored on site. *Recommended Treatment:* provide a fire extinguisher.

Summary of Work Items

SYSTEM	CONDITION	URGENCY	TASKS
safety	fair	critical	Ensure that there is an operable fire extinguisher on site.
windows	fair	urgent	Clean behind security cage. Repair trim: nail header in place. Replace sill: one 4’7” long 1x2 board. Replace broken glass: one 12” x 10” pane. Reglaze all 16 lights.
site	good	urgent	Cut overhanging tree limbs, if feasible. Rake duff and small plants back to clear a 2’ wider perimeter and uncover the foundation. Relocated storage boxes.
foundation	good	minor	Foundation - remove moss, clear out crawlspace, secure access with steel mesh.
porch	good	minor	Monitor rot on deck and top plates not covered by the roof eaves. Install a step.
walls	good	minor	Monitor surface rot. Clean walls with a mild chemical cleaner to remove growth, dirt, and smoke stains. Do not scrape or use an abrasive. Replace chinking: six 2’ long 2” wide battens with triangular profile. Replace shingles: five shingles 4-5” wide. Remove foam.
door	good	minor	Clean behind security cage. Replace door handle with appropriate replica.

Proposed Access

Roads

Millard Ranger Station and Red’s Horse Ranch are both located in the Eagle Cap Ranger District of the Wallowa-Whitman National Forest and are accessed from the Moss Springs Trailhead, which is located in the Le Grande Ranger District. The trailhead can be reached by driving 25 miles from Le Grande on OR-237-S, and Forest Road #6220. Roads are well maintained and signage is clear all the way to Moss Springs Trailhead. Follow signs for Moss Springs Campground and the trailhead. Forest Road #6220 is steep and graveled for more than 8 miles. Moss Springs Campground is a substantial, developed campground that provides ample campsites, day-use parking, and parking for stock trailers.

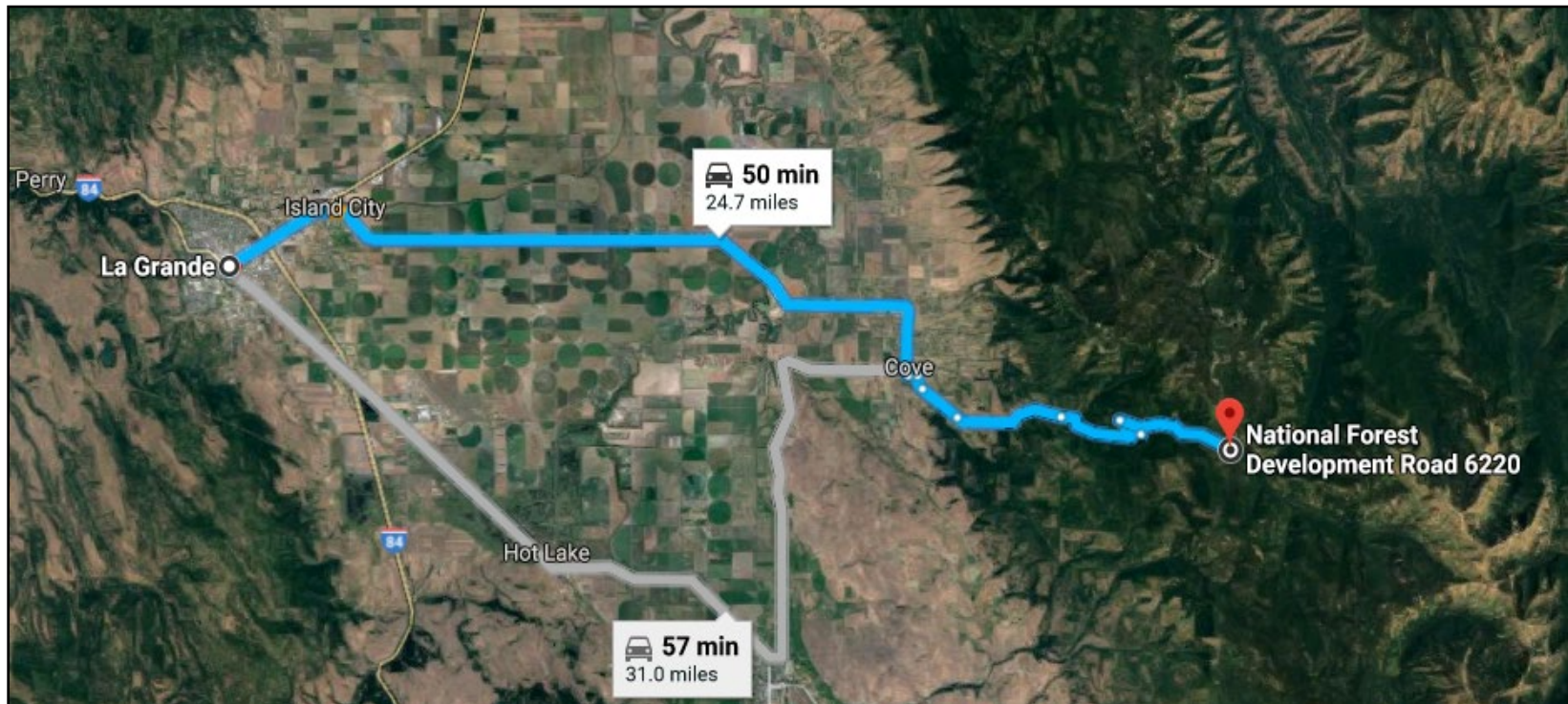

Route from Le Grande to Moss Springs Trailhead. Google Maps.

Trails

From the Moss Springs Trailhead, the Millard Ranger Station and Red's Horse Ranch are reached by travelling 7.5 miles on the Horse Ranch Trail (#1908). The trail descends from 5,842' at the trailhead to 3600' at the valley floor along the Minam River. The Horse Ranch Trail leads to a large wooden gate at the west edge of a large meadow. The main building's that comprise the Red's Horse Ranch complex are located directly east across these meadows. The barn becomes visibly shortly beyond the gate. For the Millard Ranger Station, follow worn paths across the meadow and then head south, following the tree line at the meadow's eastern edge. The Ranger Station is set back into the tree line, approximately 95' southeast of the Horse Ranch's barn. The Millard Ranger Station's coordinates are approximately 45.3430, -117.6213. The ranch's lodge, which is sometimes open to the public, is located at approximately 45.3465, -117.6264.

The Horse Ranch Trail has reliable water sources, primarily the Little Minam River, Minam River, and numerous creeks. A large group camping site is located at roughly mile 4, shortly before a bridge over Boulder Creek and a junction with the Jim White Trail. The buildings are located on wide, flat sites on the valley floor, where a sizable crew could camp and work effectively at one time. The crew size would comply with regulations for the Eagle Cap Wilderness, which prohibit parties of more than 12 persons and/or 18 head of stock. Larger parties must break into distinct groups and maintain an established distance between them. Camping in excess of 14 days within any 30-day period is also prohibited.

Trail to Millard Ranger Station and Red's Horse Ranch. Naturalatlas.com.

Staging Materials

The recommended method for future work at either Millard Ranger Station or Red's Horse Ranch would be a) a pack train from the Moss Springs Trailhead or b) plane or helicopter flights from Enterprise, Oregon to a landing strip at the Ranch.

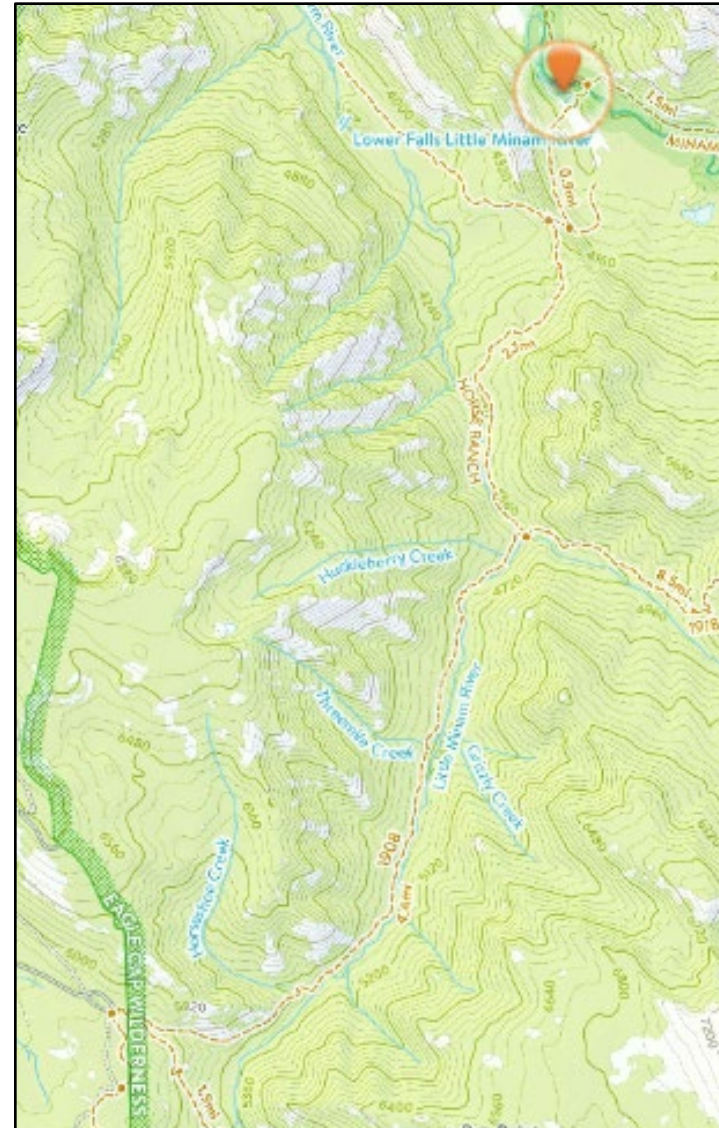

Stock - The Horse Ranch trail is frequently used for stock, and there is sufficient water all along the route. Stock can graze in the meadows around Red's Horse Ranch. The trail is steep and narrow, which makes it easy for heavy-laden animals to slip, but the trail is frequently used nonetheless.

Planes - Staging areas were not identified during this assessment, but the Ranch and several inholdings nearby are regularly resupplied by small planes that arrive from Enterprise, 13 air miles to the northwest. They land at an airstrip at Red's, which is mowed and maintained by a mule team from May to November.



Air strip at Red's Horse Ranch

Mule Peak Lookout

Eagle Cap Wilderness, Wallowa-Whitman National Forest

Charlotte Helmer, HistoriCorps Principal Investigator

December 2017



Summary

Mule Peak Lookout is located in the Eagle Cap Ranger District of the Wallowa-Whitman National Forest and can be accessed from either the Buck Creek Trailhead or the South Fork Catherine Creek Trailhead, which are each roughly 100 miles from district offices in Joseph, Oregon. For this assessment, the lookout was reached via the Elk Creek Trail (#1944), Sand Pass Trail (#1912), and Mule Peak Trail (#1924); a route that climbs from 5500' to 8679' over roughly 8 miles of trail. The lookout's coordinates are approximately 45.1304, -117.5030.

Mule Peak Lookout was constructed ca. 1940 and is a variation of the L-4 ground house design. The lookout is a single story building on top of a hybrid basalt, wood, and board-formed concrete foundation with a footprint of 14' x 14'. It is of stud framed construction, clad in horizontal shiplap boards, and has a hipped roof clad in asphalt shingles. The lookout's most distinctive features are its hipped roof and continuous casement windows and awning shutters across all four elevations. Unlike the other lookouts included in this report, it is still staffed for a few weeks each summer.

As of its assessment in August, 2017 Mule Peak Lookout is in good condition. In recent years, the siding, roof, windows, and front door have been altered with good intention but poor craftsmanship that has left the lookout ill-equipped to withstand extreme weather conditions. Furthermore, some of these alterations impact the building's historical integrity and would ideally be reversed in the future. Finally, Brian Sather, the resident fire observer has reported a few necessary changes that will make the building a more suitable and functional. Mule Peak Lookout retains a high degree of integrity in all seven of the characteristics that are typically considered: setting, location, craftsmanship, design, materials, feeling, and association.

Technologies used to monitor fire activity from Mule Peak



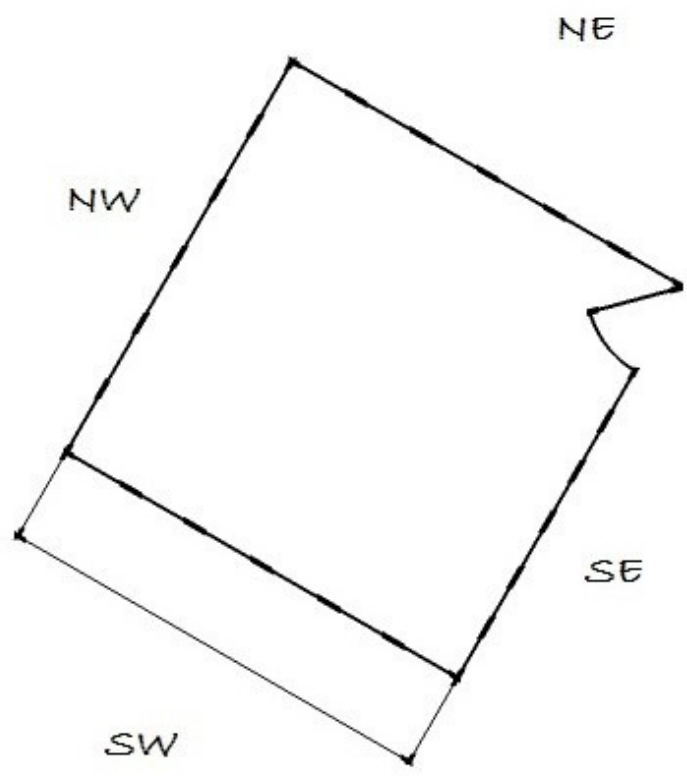

MULE PEAK LOOKOUT

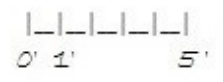

Site

Overall, the site is in good condition; common concerns such as overhanging branches, water runoff, erosion, and duff are not an issue. The lookout is built on a steep basalt base which resists erosion by water and wind. The grade drops away sharply on the building’s north side. Exposure is significant but does not appear to have impacted the foundation. It primarily affects wood and finishes on the southeast side of the building. The site provides excellent drainage and ventilation for the lookout. The Mule Peak Trail primarily runs north-south but it curves around the basalt peak and arrives at the lookout from the west and east sides. Historical viewsheds are intact. Small white pines are growing within 10’ of the building and may pose a concern in two respects: 1) as they get taller they will begin to block the fire watcher’s view, particularly to the west and 2) in the case of a fire they may provide fuel too close to the building. *Recommended Treatment:* remove trees near the lookout, if it is feasible to do so in wilderness.

Supplies and Storage - Slash piles are established on a small flat clearing near the latrine and another clearing on the building’s east side. These piles contain original shiplap siding and a mixture of brush, trash, and other construction debris. Slash piles pose a fire hazard. *Recommended Treatment:* remove or intentionally burn slash piles once any useful material has been salvaged.



Southwest and southeast elevations and site



Northwest elevation and site

Steps - A short flight of dry-laid stone steps curves from the lookout's southeast corner to the front door at the northeast corner. They rise to a height of approximately 10 feet. Several steps have lost stones and could be repaired with stones that are already on site. The stairs were once flanked by a series of metal posts and a line of chain or rope to keep visitors from falling off the steps. Now the posts remain but the line is absent. *Recommended Treatment:* replace rope or chain.

Latrine - A latrine is sited 50 feet west of the lookout and within 10 feet of the Mule Peak trail. It is built directly on basalt and there is no pit below the toilet seat. Fire watchers are tasked with cleaning out the toilet on a frequent basis. The latrine is clean and well maintained. Several small vents have broken and could be repaired with spare materials that are already stored on site. The broken vents are mostly a cosmetic concern since the latrine is rarely used. Its door is kept closed during winter months to keep snow from piling up inside and in 2017 the lookout staff improved this door by salvaged a spring from the lookout's original door. *Recommended Treatment:* repair vents. Consider relocating the latrine over a pit so that it is more useful for staff.



Typical construction and condition of dry-laid stone steps



Latrine

Exterior

Foundation - The foundation is in excellent condition. It is primarily constructed of exposed basalt bedrock but has been reinforced at the southwest side two corners. The foundation reaches a maximum height of roughly ten feet below the southwest wall. The southern part of the foundation is a wall of rough-coursed, dry-laid stones. The south and west corners are reinforced with short pressure treated 4x4 posts and a light grey mortar that probably contains a high concentration of Portland cement. Evidently, the mortar was shaped with a board-formed mold built around the dry-laid stone at each of these corners. The form appears to have been built from shiplap boards. The mortar, masonry units, and wood posts are all in good condition. Unlike all other lookouts assessed in this report, Mule Peak Lookout is not anchored to its foundation with steel plates connected at the corners. A 2' x 2' gap in the foundation's east side allows access to a crawlspace, but it was inaccessible during this assessment. The crawlspace is packed full of tools and supplies. *Recommended Treatment:* access the crawlspace and inspect the inside of the foundation; keep the crawlspace accessible.



Basalt foundation, northeast side



Reinforced foundation, west corner

Floor Structure - The floor joists were mostly inaccessible during this assessment. A single set of floor joists runs northwest-to-southeast. There is a subfloor above the joists, and the floorboards inside the lookout also run northwest-to-southeast. The resident lookout reported that cold air infiltrates through the floorboards, so it may be worthwhile to insulate the floor if this has not already been done. Old joists have been discarded in the slash piles on site. These indicate that floor has been repaired or replaced in recent years. The resident also reported that the floorboards have a slight “squishiness” near the front door where snow collects in winter. Further investigation is needed to identify if the joist below the floorboards are also failing. Otherwise, the floor joists are thought to be in good condition. *Recommended Treatment:* access the crawlspace and inspect the underside of the floor. Consider adding insulation.

Deck - A small deck roughly built of salvaged planks, joists, and posts supports two solar panels on the southwest elevation. This is almost certainly not original, but it serves a useful purpose and is a reasonable alteration of the lookout’s original design. One of the posts does not touch the ground. Otherwise, the deck is in good condition. It can be improved, altered, or removed as needed to provide a power source for the lookout. *Recommended Treatment:* shim post at the bottom using stones or wood already on site.



Typical construction of floor joists and subfloor



Typical rough construction of solar panel deck

Siding - Each elevation is clad in five rows of horizontal shiplap siding that extends from the foundation to the windowsills. The sheathing underneath was inaccessible but is assumed to be in good condition. All of the siding appears to have been replaced in recent years, but is only in fair-to-good condition. The material appears to be low-quality cedar that lack a clear, straight grain. Several boards on each elevation have vertical cracks that will expand along the grain if left untreated. The new siding and trim was left unpainted, which has left the material exposed to damage by water, wind erosion, and UV. *Recommended Treatment:* patch cracks with caulk.

Trim - Corner boards are all in place but many are weathered and cracked. These are mostly cosmetic details and they could be patched with caulk. Trim around the front door has been roughly altered to accommodate a prefabricated door. The door trim is functional, but it is an obvious anachronism and could be restored to the original design to restore the building’s traditional look. *Recommended Treatment:* replace doorway trim and paint it to conceal finger joints.

Finishes – Painted surfaces are in good condition. Unpainted surfaces of the lookout were previously painted with a grey latex-based paint. *Recommended Treatment:* treat all unpainted wood with primer and paint. This will restore the lookout’s traditional appearance but, more importantly, it is a necessary measure that will extend the lifetime of the siding which protects the wall structure underneath.



Corner boards



Typical condition of shiplap siding



Doorway trim

Shutters - The shutter system is in good condition. Each elevation has two or three awning-style shutters constructed from horizontal boards reinforced with vertical and diagonal braces. The door does not have a shutter, which is unusual for an L-4 lookout. All the shutters are designed to be held open with wood struts. Two rows of horizontal shiplap siding above the windows has been altered on each elevation to support the shutters below. The shutter hinges are fastened to two 1x5 horizontal boards that were installed on top of the siding. Radio equipment is also anchored to these added boards. They are probably not original but serve a useful purpose by reinforcing the shutters. The lookout resident reported that it is difficult (even unsafe) for a single person to open these shutters. *Recommended Treatment:* replace nuts and bolts with square wire lock pins to make the hardware easier for one person to manage. The shutters' weight, height, and hardware can more easily be managed with two people, so the Forest Service staff could ensure that two people are available to change the shutter system at the beginning and end of fire season.



Shutter system

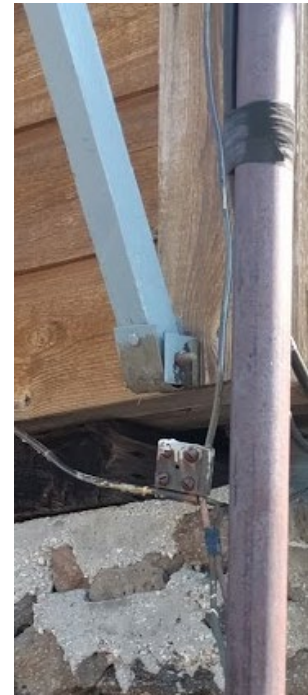

Shutter hardware

Windows - Overall, the window system is in good condition. These elements are highly significant architectural features that define the lookout's historical character and function. They also serve a critical structural purpose by protecting the interior, walls, floor, and foundation from weather damage and keep the building secured. Mule Peak Lookout's windows are very unusual. They are horizontal casement and sliding sash, shorter than the windows of most lookouts, and their interiors are decorated with a simple routed detail. Each elevation has six sashes arranged in pairs. On the elevations that do not also have a door, the center window opens by sliding. Each sash is glazed with single pane of glass. The glazing putty is quite hard and sloppily applied, but intact. It does not need to be repaired or replaced. The paint is in good condition. Small sections have flaked off and reveal the putty underneath. Operable windows on the northeast and northwest elevations allow snow flurries inside the lookout. Mullions, muntins, and quarter round trim are all in good condition. *Recommended Treatment:* weather-strip the operable windows to weatherize moisture infiltration. Touch-up paint.



Construction of fixed and sliding sash

Windows sills - Like the shiplap siding, these window sills were replaced with cheap lumber that lacks a clear, straight grain. It is likely that they are even made of the same material cut into 14' sections which would be correctly sized for siding but too short for sills. The sills are unpainted and flat, rather than sloped to shed water. The undersides are treated with a bead of white caulk. Several have cracked and are unpatched or ineffectively patched with caulk. The ends of each sill should meet at a beveled corner, but the lumber is too short and each corner is patched with up to ½" of caulk. The window sills are intact but they appear to have been replaced along with the siding, and a combination of poor planning and poor craftsmanship has created an altered design that will not last as long as the originals likely did. If archival or maintenance records can confirm the original design, it could be restored. *Recommended Treatment:* consult records for a better understanding of original architectural details; then consider replacing window sills.



Typical condition of window sills, unpainted and caulked

Door - The lookout's door is located on the southeast elevation. It is a prefabricated replacement and does not resemble the original door, which is still stored on site. The new door is in good condition with panes, muntins, panels, and hardware intact. It has an external lock. There are no function concerns associated with this feature, other than a need to keep snow flurries out. A signature suggests that it was installed ca. 2007. The original doorway was significantly altered to accommodate the new door. The hardware does not match the original hardware, nor does it fit the new door. Although the current door is in good condition, it detracts from the lookout's historical integrity. The lookout resident commented that even from a distance the new door looks "wrong." If the existing door remains in place it could at least be weatherized and painted. Ideally, the original door would be restored or reconstructed. It was not examined during this assessment but it is certainly salvageable. *Recommended Treatment:* consider restoring the original door.

Roof - The hipped roof was not accessible during this assessment but both the structure and the cladding appear to be in good condition. The roof is treated with cedar shingles that have a standard 5" reveal. Shingles along the ridges are cupping and will likely fail first. The resident reported that the roof leaks around the stove pipe and may need to be reflashed. *Recommended Treatment:* inspect the chimney to verify that it is flashed effectively.



Replacement door

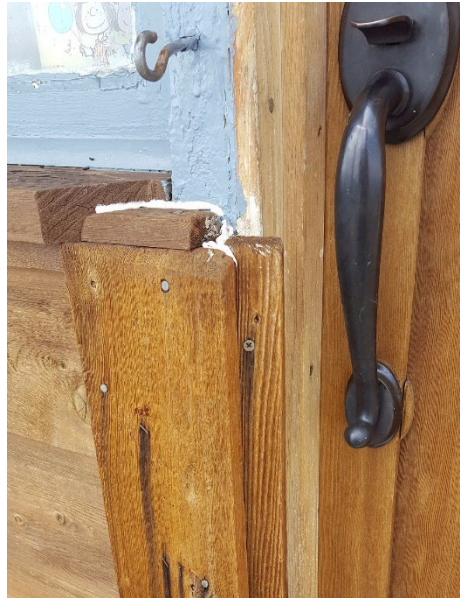

Hardware and trim



Original door

Interior & Operations

Mule Peak Lookout's interior is in good condition. The floor, walls, trim, ceiling, and finishes are all well maintained. The appliances and furniture are functional. What follows are a few recommendations to make the building more livable for occupants and more effective as an active lookout during fire season:

Ceiling and Attic - The ceiling requires a new coat of white latex-based paint. An access hatch to the attic has been sealed with nails and painted over. Although the attic was inaccessible, it is likely that rodent nests and water damage need to be addressed. *Recommended Treatment:* open the hatch and maintain it as an operable access point so that the attic can be assessed and maintained.

Safety - The lookout is safe for staff and visitors. In August of 2017 a guyline at the north corner of the lookout broke off, severed at its anchor in the basalt bedrock. *Recommended Treatment:* repair the guyline as soon as possible; it may be critically important.

Security - A cable is run through the eye bolts and fastened with a griphoist to hold the shutters closed. This system is probably not original and the cable is scarring the lookout's corners. However, the system is effective and could be continued. *Recommended Treatment:* reinforce the corners with small pieces of aluminum flashing or a similar protective layer to prevent more damage.



Ceiling condition



Broken guyline



Griphoist and cable

Appliances - The lookout in residence reports that the refrigerator is substantially larger than needed and it blocks sight-lines and radio signals that are both essential for the lookout's work. It could be replaced with a smaller unit such as a mini-fridge. The wood stove, an Osborn box stove, is also over-large for the small interior space. The resident reports that this stove does not ventilate properly; There is an issue with the dampener and the stove will only operate if its door is open poses fire hazard. It is recommended that this stove be a) repaired by a capable technician or b) removed and replaced with a smaller stove. Although the lookout is also equipped with propane and solar power, a stove is probably the most reliable way to heat the building during winter when Mule Peak Lookout occasionally used for snow surveys. In all seasons it is used to burn trash and provide heat, but it is not often used for cooking. The resident reports that the stovepipe leaks and may not be flashed correctly. Furthermore, he has seen sparks fly out of the stovepipe's top and land on the ground outside the lookout. He has climbed up on the roof recently to adjust the stovepipe at its base, but it may need to be reflashed. On the south side of the lookout, a rough platform supports two solar panels. One is connected to new "Mule Peak" repeater. The other is connected to a battery and a defunct (or back-up) repeater. The lookout resident uses solar power to charge other electronic devices, such as a laptop and cell phone. One of the solar panels has displaced a strut that holds a shutter open. This may cause the shutter or remaining strut to fail over time, but it is not an immediate concern.



Refrigerator



Stove



Stovepipe



Solar panel



Repeater

Fuel Storage - Propane and tools are stored on a flat spot adjacent to the building. A concrete slab further downhill on the east side used to provide a safe place for storing propane tanks inside a short wooden fence. Lookout staff relocated the propane supply because the concrete slab tipped. Propane tanks are connected to kitchen appliances and light fixtures inside the lookout via hoses that run through a gap in the foundation which allows access to the crawlspace. A large supply of firewood is also stored on the west side of the building.
Recommended Treatment: consider storing propane away from the lookout or phase out propane use in favor of solar power.



Slash pile, discarded lumber, and propane storage on the east side



Concrete slab formerly used for propane storage

Summary of Work Items

SYSTEM	CONDITION	URGENCY	TASK
safety	poor	critical	Replace broken guyline
finishes	poor	critical	Apply primer and two coats of paint to all unpainted parts of the exterior, and to the ceiling (3 gallons each)
walls	poor	urgent	Patch with caulk; Consider replacing window sills
windows	fair	urgent	Weatherize operable windows to keep out snow and rain
door	fair	urgent	Weatherize threshold to keep out snow and rain; Restore original door to improve historical appearance and retain original material
appliances	fair	urgent	Replace wood stove and refrigerator; Inspect flashing around the stove pipe
fuel	fair	urgent	Consider relocating propane canisters or phase out propane use entirely
roof	good	urgent	Access attic; inspect and monitor for rodents and water damage to roof and ceiling
site	good	minor	Burn off or remove slash piles, thin vegetation (as appropriate) to reduce fire hazards
floor	good	minor	Access crawlspace; inspect and monitor for water damage to floor near threshold
shutters	good	minor	Consider replacing nuts and bolts with pins; reinforce shutter over solar panels
security	good	minor	Flash corners to prevent scarring from the security cable
latrine	good	minor	Repair vents; Consider relocating over a dug-out pit

Proposed Access

Roads

Mule Peak Lookout is located in the Eagle Cap Ranger District of the Wallowa-Whitman National Forest and can be accessed from either the Buck Creek Trailhead or the South Fork Catherine Creek Trailhead. Either trailhead can be reached by driving 100 miles from the Wallowa Mountains Office in Joseph, OR on OR-82 W and OR-203 S. Catherine Creek Lane provides access to Buck Creek via Forest Road #7787 along the North Fork of Catherine Creek. The same road also provides access to the trailhead at the South Fork of Catherine Creek via Forest Road #650. Roads are well maintained and clearly signed all the way to the trailheads. However, maps of the Eagle Cap Wilderness and Wallowa-Whitman National Forest are all out-of-date. It is important to discuss routes with the forest's wilderness staff before setting out on any significant backcountry trip. Buck Creek trailhead offers plenty of room for trucks, trailers, and stock animals. Conditions at the South Fork trailhead are unknown.

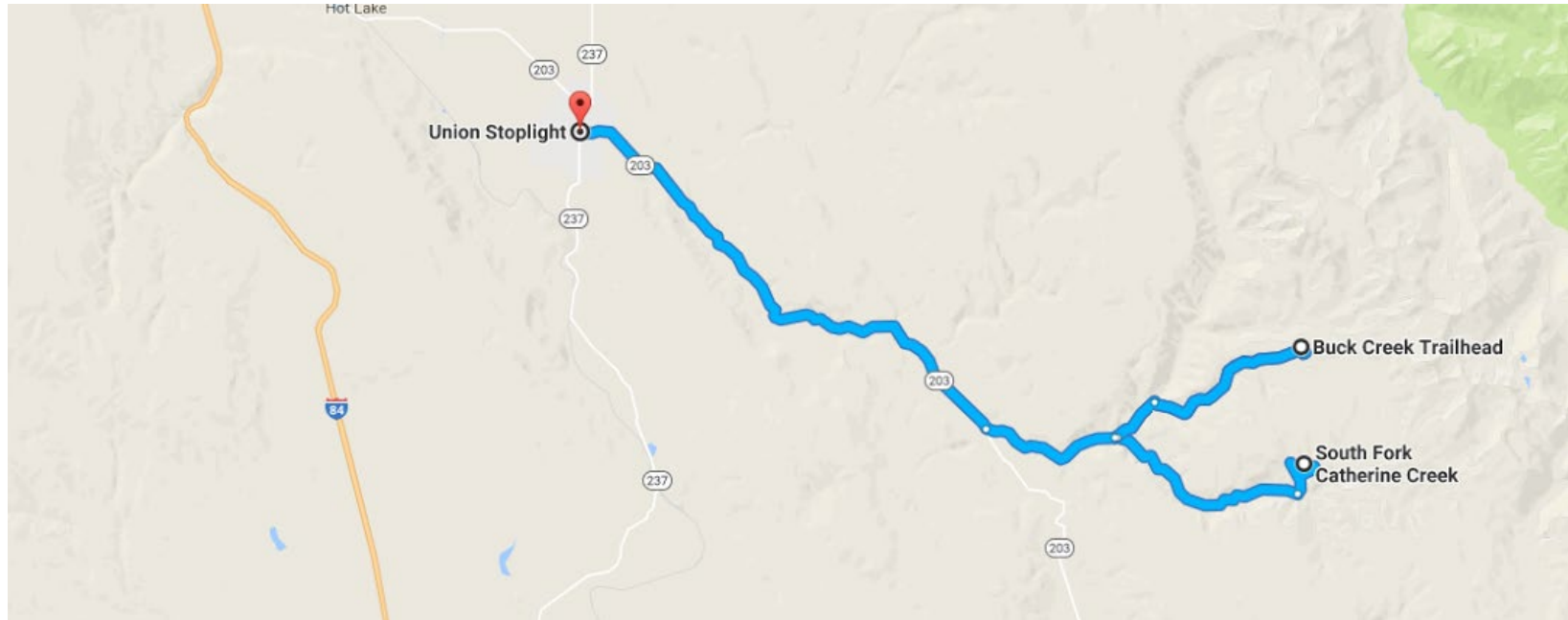

Route from Union, OR to the Buck Creek Trailhead and South Fork Catherine Creek Trailhead. Google Maps.

Trails

For this assessment, the lookout was reached via the Elk Creek Trail (#1944) from Buck Creek Trailhead to Burger Pass, then the Sand Pass Trail (#1912), and the Mule Peak Trail (#1924) to reach Mule Peak Lookout from the north. This northern route is long but well maintained and clearly signed all the way to the lookout. It climbs from approximately 5500' to 8679' over roughly 8 miles of trail. Alternatively, the lookout can be reached by starting at the South Fork of Catherine Creek and following the Sand Pass Trail (#1912) and the Mule Peak Trail (#1924) to reach Mule Peak Lookout from the south. This southern route is shorter, but quite steep and poorly maintained in some places. It climbs from approximately 5000' to 8679' over just five miles of trail. The lookout's coordinates are approximately 45.1304, -117.5030.

The Elk Creek Trail (#1944) has occasional water sources, small stream crossings, and campsites almost all the way to the junction with the China Ridge Trail (#1906) below Burger Pass. In late summer, the most reliable water source beyond this junction are the streams that flow through Burger Meadows. In early summer, snow banks and a spring near Mule Peak provide water sources closer to the lookout. The spring is located 750 vertical feet towards the south.

A large group campsite at the center of Burger Meadows might be appropriate for a stock team or preservation crew. The Sand Pass Trail and Mule Peak Trail offer small camping sites for dispersed tents but these areas do not offer significant shelter during hazardous weather conditions, such as lightning storms. The lookout is positioned on a steep site where no more than 6 crew members could work effectively at one time.

Mule Peak Lookout seen from Sand Pass





Sand Pass seen from Burger Pass



Looking back at Burger Pass and Burger Meadows from Sand Pass

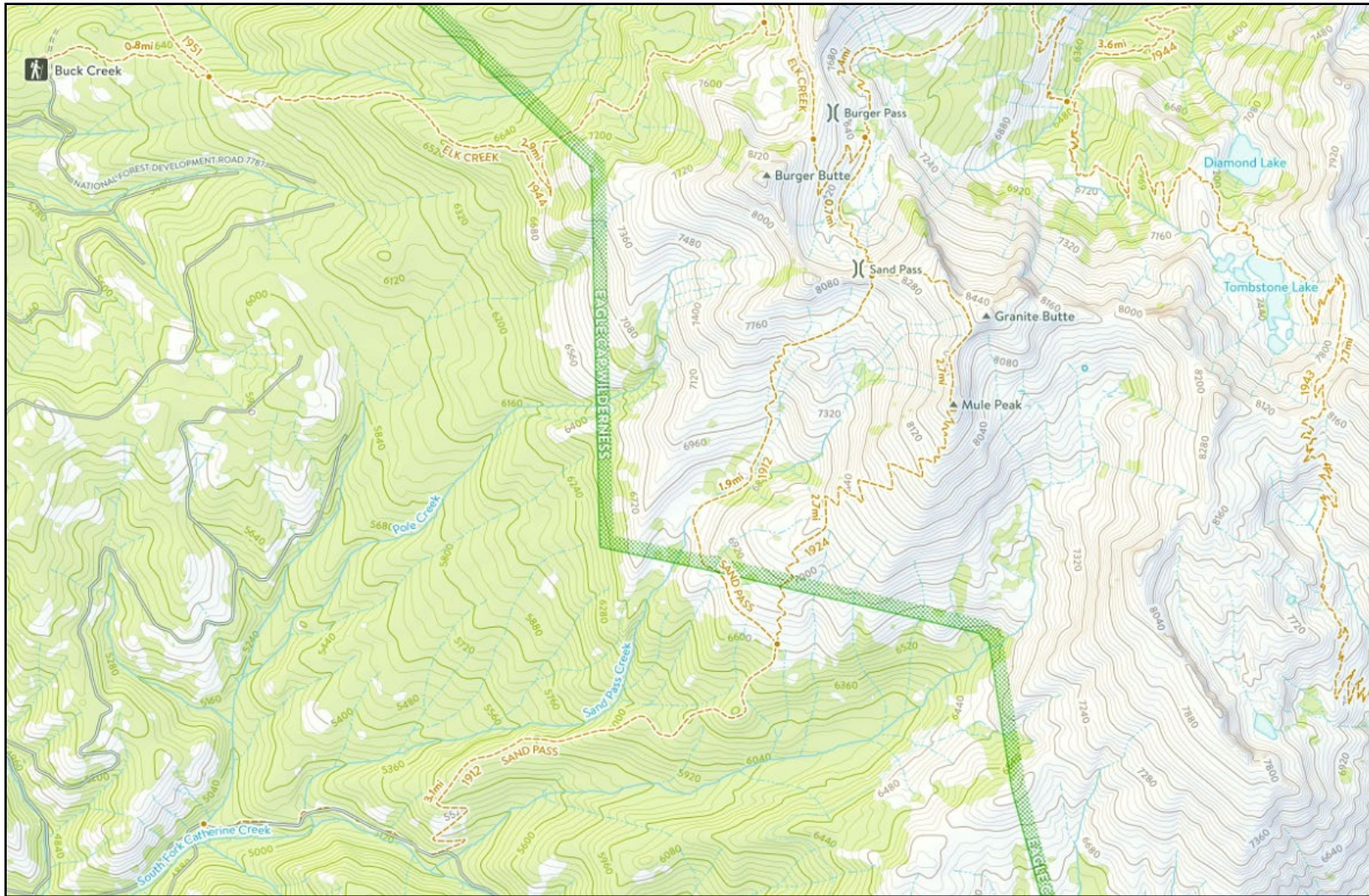

Map of Buck Creek Trailhead, Elk Creek Trail, Sand Pass Trail, Mule Peak Trail, and Mule Peak. www.naturalatlas.com.

Staging Materials

The recommended method for future work at Mule Peak Lookout would be a) helicopter flights from an unidentified staging area to a drop-point near Mule Peak, which has been used to supply the lookout in the past, or b) a pack train from the Buck Creek Trailhead.

Helicopters - Staging areas were not identified during this assessment, but several clearings and parking areas along the South Fork of Catherine Creek could provide enough room. A drop-point to the south of Mule Peak Lookout has probably been used to resupply the station in the past. A saddle between Mule Peak and Granite Butte would also be suitable for helicopter landings.

Stock - The Buck Creek Trailhead provides ample room for a stock trailer. Eagle Creek Trail is open for stock use and is frequently used for that purpose, but Sand Pass Trail and the Mule Peak Trail maybe unsuitable for stock. However, telephone wires along the route indicate that it is likely an original trail to Mule Peak Lookout, in which case it may have been used to supply the lookout with pack animals in the past. Sand Pass itself poses a challenge for stock because it is very steep and the footing is not sound. A stock trail might use the Sand Pass from the southern end, at the South Fork of Catherine Creek but that trail was not explored during this assessment. Burger Meadows provides ample space to string up a high-line, unpack the train, and camp with a group. Water sources near the lookout are insufficient for stock.



Buck Creek Trailhead



Saddle between Mule Peak and Granite Butte

Olallie Mountain Lookout

Three Sisters Wilderness, Willamette National Forest

Charlotte Helmer, HistoriCorps Principal Investigator

December 2017



Summary

Olallie Mountain Lookout is located in the McKenzie River Ranger District of the Willamette National Forest and is accessed from the Pat Saddle Trailhead, 25 miles from the district headquarters in McKenzie Bridge, Oregon. From the Pat Saddle Trailhead, the lookout is reached by Olallie Trail #3529 and Olallie Mountain Trail #4100. The route is 3 miles long and ascends from 5,425 feet at the trailhead to 5,700 feet at the lookout. The lookout's coordinates are approximately 44.0288, -122.0682.

The lookout is a single story building on top of a rubble pier foundation with a footprint of 14' x 14'. It is of stud framed construction, clad in horizontal shiplap boards, and has a front-gable roof clad in shingles. The lookout's most distinctive features are its continuous windows and shutter across all four elevations. A single door with windows is offset in the facade. Olallie Mountain Lookout exemplifies the earliest iteration of the L-4 lookout type which had a gable roof and shutters held open with diagonal braces.

As of its assessment on July 10, 2017 Olallie Mountain Lookout is in poor condition. The foundation, east and west walls, and roof are in critical condition. Nevertheless, Olallie Mountain Lookout retains integrity in all seven of the characteristics that are typically considered: setting, location, craftsmanship, design, materials, feeling, and association.

The lookout's structure is in critical condition which threatens its integrity. Preservation would require a substantial intervention, begun by removing the roof and siding in order to reinforce and repair the structure underneath. Fortunately, most of the building's original cladding material can be reinstalled. Preservation projects could be completed by a small group of experienced preservation carpenters or volunteers supervised by experienced project managers.

All proposed actions are dependent upon the forest's management decisions and the MRDG process.

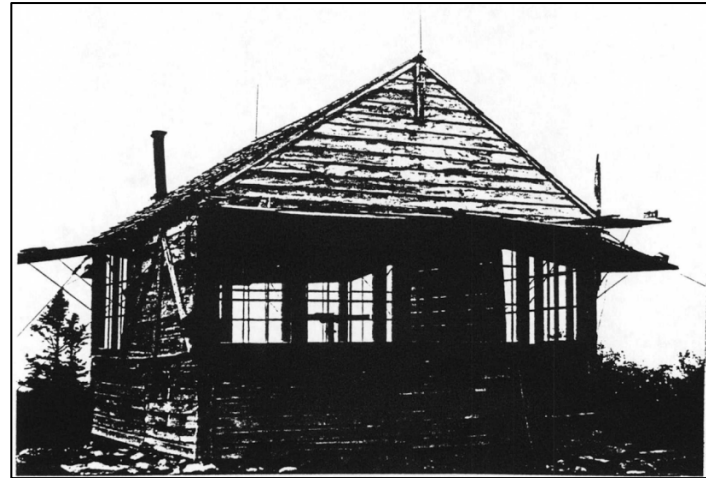

Olallie Mountain Lookout, ca 1990. USFS.

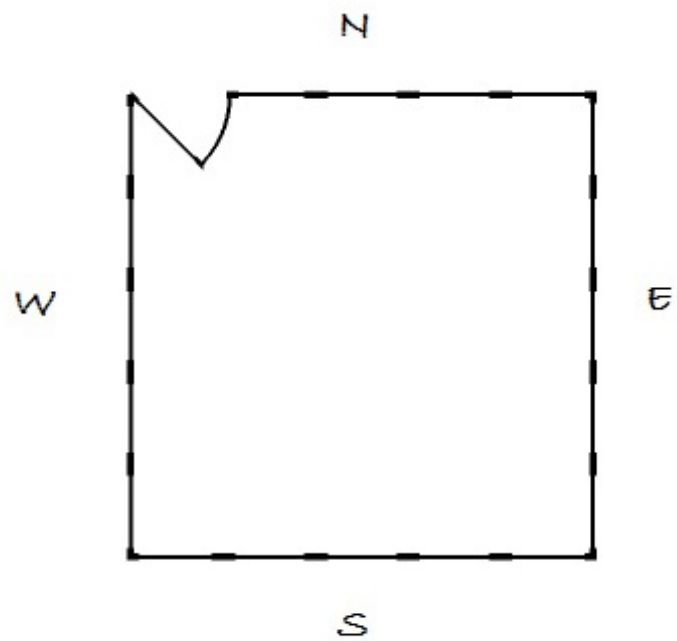

OLALLIE MOUNTAIN LOOKOUT



Site

Olallie Mountain Lookout is sited on a solid base of rock with steep slopes descending to the southwest and gradual slope to the northeast. The Olallie Mountain trail leads directly to the lookout's front door and the north elevation where a small clearing provides flat open ground on the building's north and east sides. Overall, the site is in good condition; common concerns such as overhanging branches, water runoff, erosion, and duff are not an issue. The site provides excellent drainage and ventilation for the lookout. Historical view sheds are intact. Exposure is significant but not extreme and it primarily affects the southeast side of the building. Trash and lumber from the lookout is strewn across the site. *Recommended Treatment:* consider removing vegetation that is close to the building, and remove trash from the site.



West and north elevations

Exterior

Foundation - Olallie Mountain Lookout has a footprint of 14' x 14' and rests on a foundation of dried-laid stone piers, 6" - 1' high. The foundation is in critical condition. Existing piers below the east and west elevations are insufficient to support the floor structure above, largely because the roof and wall structures have failed. *Recommended Treatment:* additional piers could be built at the center of the east and west walls where joists are sagging, but this may not be necessary if other structural concerns are addressed.

Floor Structure - A set of three doubled joists runs north-south and supports a second set of doubled joists that run east-west and are spaced about 2' apart. All joists are made from boards with a 2" x 5" profile. The subfloor is constructed of wide boards running north-south. All materials are in excellent condition, but the joists that run parallel to the east and west walls are insufficiently supported by the foundation and are out of place. *Recommended Treatment:* jack joists back into place and consider reinforcing them from the underside where alteration will not be visible. This may not be necessary if other structural concerns are addressed.

Wall Structure - The lookout is framed in nominal 2" x 4" studs spaced 2' apart and reinforced with diagonal braces. A temporary wall across the interior reinforces the ceiling and walls. All materials are in good condition, but a structural failure in the roof has placed the east and west walls in critical condition. These walls have buckled out approximately 6" from plumb. Nevertheless, corner-to-corner measurements across the interior indicate that the lookout is still primarily still square, level, and plumb despite the structural failures at the center of two walls. The east and west sides have hinged along a vertical axis (unsupported by the foundation) and a horizontal axis (weakened by a row of windows). *Recommended Treatment:* reinforce studs with additional 2x4s which will be concealed behind the siding. This may not be necessary if other structural concerns in the roof are addressed and seem to be sufficient.



East wall condition



West wall condition



West wall exterior



West wall interior



Temporary interior wall

Exterior siding - Each elevation is clad in horizontal lap siding over tarpaper. The gable ends are 14' across and approximately 5'6" tall. Wall sections below the windows are approximately 14' across and 3' high. The siding is in poor condition due to weathering, UV damage, cracking, and cupping. Siding boards are 5-1/4" wide with 5" reveal and a beveled profile. Boards are cracked, cupped, and weathered to a mere 1/8 inch thick. The east and west walls were clad with 8' and 6' boards aligned so that their seams are continuous. This is not a significant characteristic and may be part of the problem that has caused these walls to buckle. When the roof structure and wall are repaired, new siding could be installed in an alternating pattern. Typically, all horizontal materials including siding, sills, trim, and headers are applied in both 8' and 6' lengths. *Recommended Treatment:* replace all siding on the east, south, and west elevations.



Typical construction



Typical condition below and above windows

Exterior trim - Each elevation is trimmed with short corner boards below the windows, tall corner boards alongside the windows, window aprons, window sills, and headers that support the shutters from above the windows. Overall, the trim is in fair condition. Most of the damage is concentrated on the southeast side of the building where weathering and exposure are the most severe. *Recommended Treatment:* replace broken pieces of trim. Six short corner boards and two tall corner boards need to be replaced. They have a profile of 1-½" x 4-¼" (nominally 2" x 5") and are 3' and 4'3" long, respectively. One window apron needs to be replaced. It is 8' x 3-½" x ¾" (nominally 1 x 4). Three window headers need to be replaced on the north and south elevations. These boards have a 2" x 2-½" profile. Two headers need to be replaced on the west elevation, and have a slightly larger profile of 2" x 3-½". 3 window sills need to be replaced; they are 6" x 1-½" and beveled to 1".

Exterior finishes - Weathering, UV damage, and exposure have stripped almost all paint from the exterior, particularly on the southeast side. *Recommended Treatment:* prime and paint all wood surfaces.

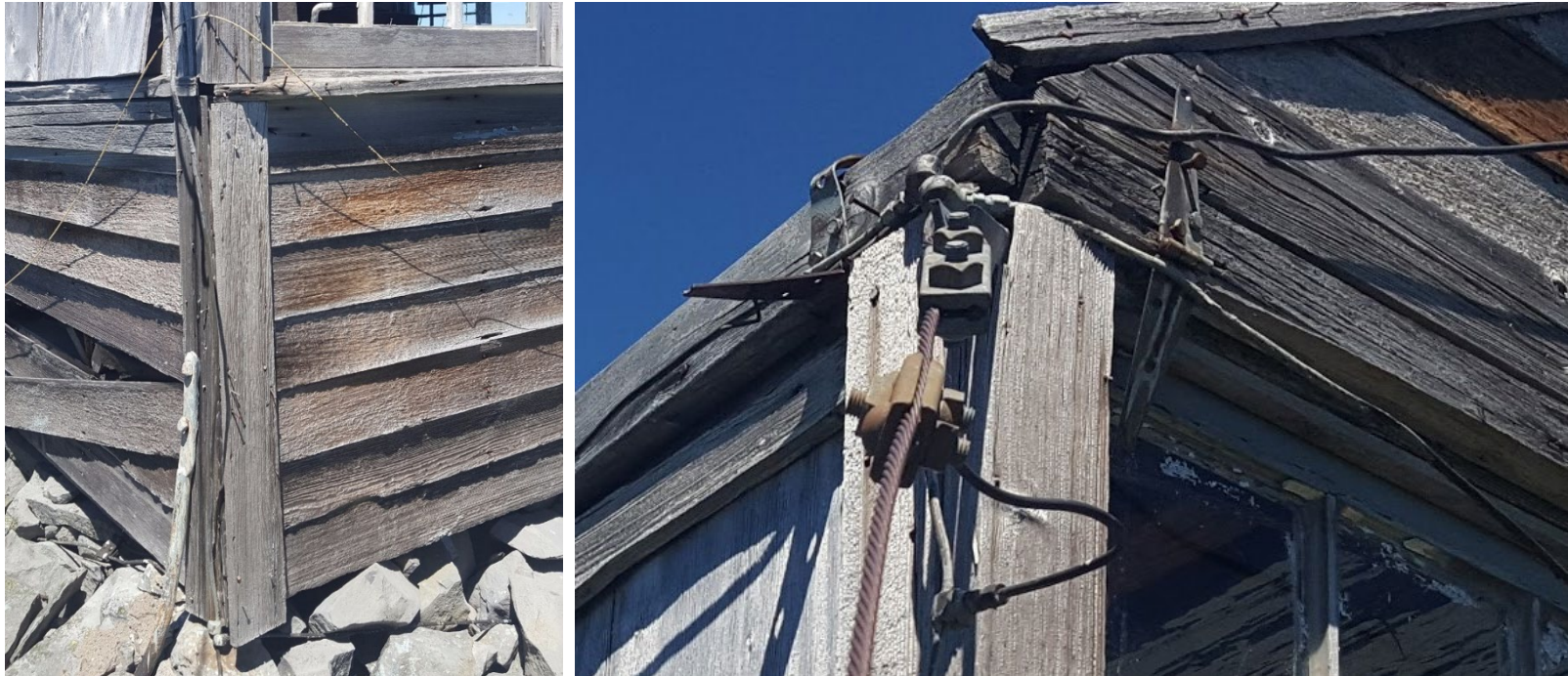

Typical trim construction below and above

Shutters - The shutter system is in poor condition. Each elevation has two awning-style shutters constructed from a single layer of 1” thick horizontal boards reinforced with vertical and diagonal braces. Boards are fastened with 3” nails. The shutters are designed to hang suspended from the window headers above. Shutters come in three sizes. Small and medium-sized shutters have two vertical braces and one diagonal brace. Large shutters have three vertical braces and two diagonal braces. A small shutter hangs over the door and is in good condition. Several shutters have been replaced with plywood. The shutter hinges are in fair condition. Small and medium-sized shutters have two diamond-shaped hinges while large shutters have three. There are no latches to hold the shutters closed or open. 15 hinges can be reused. *Recommended Treatment:* reconstruct two medium-sized shutters and two large shutters. Repair three medium-sized shutters and one large shutter by replacing damaged boards. Replace six hinges.



Typical construction



Typical condition of large and medium-sized shutters



Hinges

Windows - Overall, the window system is in poor condition. These elements are highly significant architectural features that define the lookout's historical character and function. They also serve a critical structural purpose by protecting the interior, walls, floor, and foundation from weather damage and keep the building secured. Olallie Mountain Lookout has 19 nine-lite casement windows. Three elevations each have a row five windows; the facade has a row of four windows. Two operable windows pivot on a horizontal axis. Panes of clear plate glass are installed with tab glazing points and putty. 22 panes are missing or broken. The original putty is substantially missing, damaged, or poorly repaired. An operable window on the east elevation has a cracked sash that can be repaired with wood glue. Sash on the east and west elevations have shifted out of place and will need to be reinstalled when the wall is stabilized. *Recommended Treatment:* replace broken panes and re-glaze all windows; repair the broken sash with wood glue or epoxy.

Door - The lookout's single door is on the north elevation. It is in good condition with panes, muntins, and panels intact. A small amount of damage to the woodwork could be patched with wood filler and the door could be repainted. The threshold dripline has broken off and could be repaired. The padlock and hasp have been removed. *Recommended Treatment:* repair the threshold and patch minor damage to the door's surfaces with woodfiller.



Exterior condition



Interior condition



Door condition

Roof structure - The lookout's front gable roof was primarily inaccessible during this assessment but it is clearly in critical condition and has probably caused the structural problems that have been observed in the building's walls and floor. The roof is framed with king post trusses placed 2' apart and sheathed in wide boards. All materials are in good condition, but ridge is saddle-backed. The roof is sheathing in wide boards that are exposed to the weather because the roof cladding has failed. *Recommended Treatment:* reinforce roof trusses with collar ties, even though that will alter the building's original design. It is a discrete and necessary intervention that will prevent the failure from reoccurring. Inspect sheathing for water damage and replace boards as needed.

Roof cladding - The roof is typically clad in cedar shingles, but all are in critical condition. Shingles on the west side of the roof are extremely weathered and most are missing. The east side of the roof is stripped of shingles. Two 5' high stacks of cedar shingles are stored inside the lookout and appear to be in good condition. *Recommended Treatment:* replace all shingles.



Roof structure construction and condition



East roof condition

Interior

Floor - The floor and subfloor are in fair condition. Otherwise, the floorboards are worn and pitted by a pest infestation which has not affected the structural integrity of the floor. Floor boards are buckling between joists but none have broken or cracked. *Recommended Treatment:* reinstall the floorboards once other structural concern have been addressed and the building is level, plumb, and square.

Walls - The wall cladding, trim, and finishes are in fair condition overall, but the east and west walls are in poor condition. Walls are clad in beadboard. Window sills, headers, and mullions are all in good condition. A 3' long section of quarter-round trim over the door is missing. *Recommended Treatment:* reinstall the beadboard and trim once other structural concern have been addressed and the building is level, plumb, and square. Replace the absent piece of trim.

Ceiling -The ceiling joists were mostly inaccessible except where they can be seen through an attic hatch. They appear to be in excellent condition. Ceiling boards (the same beadboard as the walls) exhibit some sagging and need to be secured to the ceiling joists. This may be caused by the weight of trash in the attic, water infiltrating from the roof and causing boards to swell, or tension and expansion at various points in the buckling east and west walls. 10% of the ceiling boards are missing or broken. The beadboard has a profile of 3 ½" x ¾" and is in 8' or 5'7" lengths. *Recommended Treatment:* reinstall the ceiling once other structural concern have been addressed and the building is level, plumb, and square.

Interior finishes - The interior is finished with a white latex-based paint over a dark green treatment. Almost all paint has failed. Lead content was not tested during this assessment. *Recommended Treatment:* test for lead content, scrape and clean all surfaces, and apply primer and paint to match the current paint campaign.



Floor and wall condition



Ceiling condition

Additional Features

Mechanical Systems - The lookout's mechanical systems and furniture have been removed. A disconnected stovepipe emerges from the southeast roof. There are no artificial lighting, ventilation, plumbing, or fire suppression systems. A lighting rod, copper cap, and four grounding wires are installed on the roof. The fire finder is absent but its podium still stands in the center of the room.

Onsite Tools and Materials - Cedar shingles, spare lumber, shovels, and a broom stashed inside the lookout. These could be used in small repairs or to augment supplies for a restoration project but are not a significant source of materials.

Trash - The site and interior are strewn with broken glass, tarps, paint chips, broken shingles, and other trash. Trash has collected in the attic. This condition encourages other visitors to leave their trash behind and/or damage the interior. It also encourages animals and insects to occupy the building. Finally, this debris traps moisture, stains and scratches the interior. *Recommended Treatment:* remove trash and unnecessary supplies.

Security- The building is not secured against animals or trespassers. Trespassers can enter through the door. Animals can enter through broken windows, buckled walls, and uncovered stovepipe. Animals and people have access to the attic as well. Fortunately, visitors have not vandalized or damaged the lookout to any significant degree. A Master lock is onsite. *Recommended Treatment:* In the short term, broken windows can be secured with plywood but considering the logistical challenge of bringing materials to this remote site it might be more efficient to remove the sash, stabilize the walls, and replace the shutters as a means of securing the lookout. Then the sash could be repaired off-site and re-installed. The door could either be locked or annotated with a sign that explains the lookout's significance, invites visitors to use it, and asks them to treat the building with respect.

Safety - The lookout is not safe for visitors but its hazards should be obvious to anyone who arrives at the site. It does not pose any hidden structural concerns. Rodent droppings and trash inside the lookout create a potential harm from Hanta virus and tetanus. *Recommended Treatment:* clean the interior and provide a sign to notify visitors of the risks caused by the lookout's condition.

Summary of Work Items

SYSTEM	CONDITION	URGENCY	TASKS
roof	poor	critical	Install collar ties on all trusses: eight 8' 2x4s. Inspect sheathing for water damage. Realign top plates as needed. Restore structure to plumb and level. Repair saddle-backed ridge. Replace all shingles: moisture barrier, 2 squares cedar shingles.
walls	poor	critical	Replace siding: thirty 8' and thirty 6' long 1x8 shiplap boards. Repair studs as needed: repurpose lumber from temporary interior wall to repair or strengthen studs as need. Remove temporary wall. Reinstall interior cladding: six 8' long 3½"x¾" beadboard for breakage.
floor structure	poor	urgent	Reinforce joists at east and west walls as needed: build dry-laid stone piers with stone on site
finishes	poor	urgent	Prime and paint (5 gallons each).
shutters	poor	urgent	Repair and rebuild shutters: twenty-six 8' long 1x4s, eighteen 6' long 1x6s, twenty-one 8' long 1x6s.
windows	poor	urgent	Replace glass: twenty-two 6" x 8" x ⅜" panes. Reglaze all sash.
exterior trim	poor	minor	Replace trim: three 8' long 1x5 corner boards, one 1x4 window apron, three 8' long 2" x 2-½" headers, two 8' long 2" x 3-½" headers, three 8' long 6"x 1-½" boards beveled to 1" thickness for window sills
door	fair	minor	Repair: wood filler. Replace hardware: one hasp.
ceiling	fair	minor	Repair ceiling: fifteen 8' long pieces of 3½"x¾" beadboard
interior trim	good	minor	Replace trim: one 3' long piece 1" quarter-round trim

Proposed Access

Roads

Olallie Mountain Lookout is located in the McKenzie River Ranger District of the Willamette National Forest and is accessed from the Pat Saddle Trailhead. The trailhead can be reached by driving 25 miles from the district headquarters in McKenzie Bridge via s OR-126-W, Aufderheide Drive, and Forest Road #1993. Roads are well maintained, and signage is clear all the way to Pat Saddle trailhead, although four-wheel-drive is advisable. The trailhead offers room for approximately 10 cars and there is room for a truck and trailer.

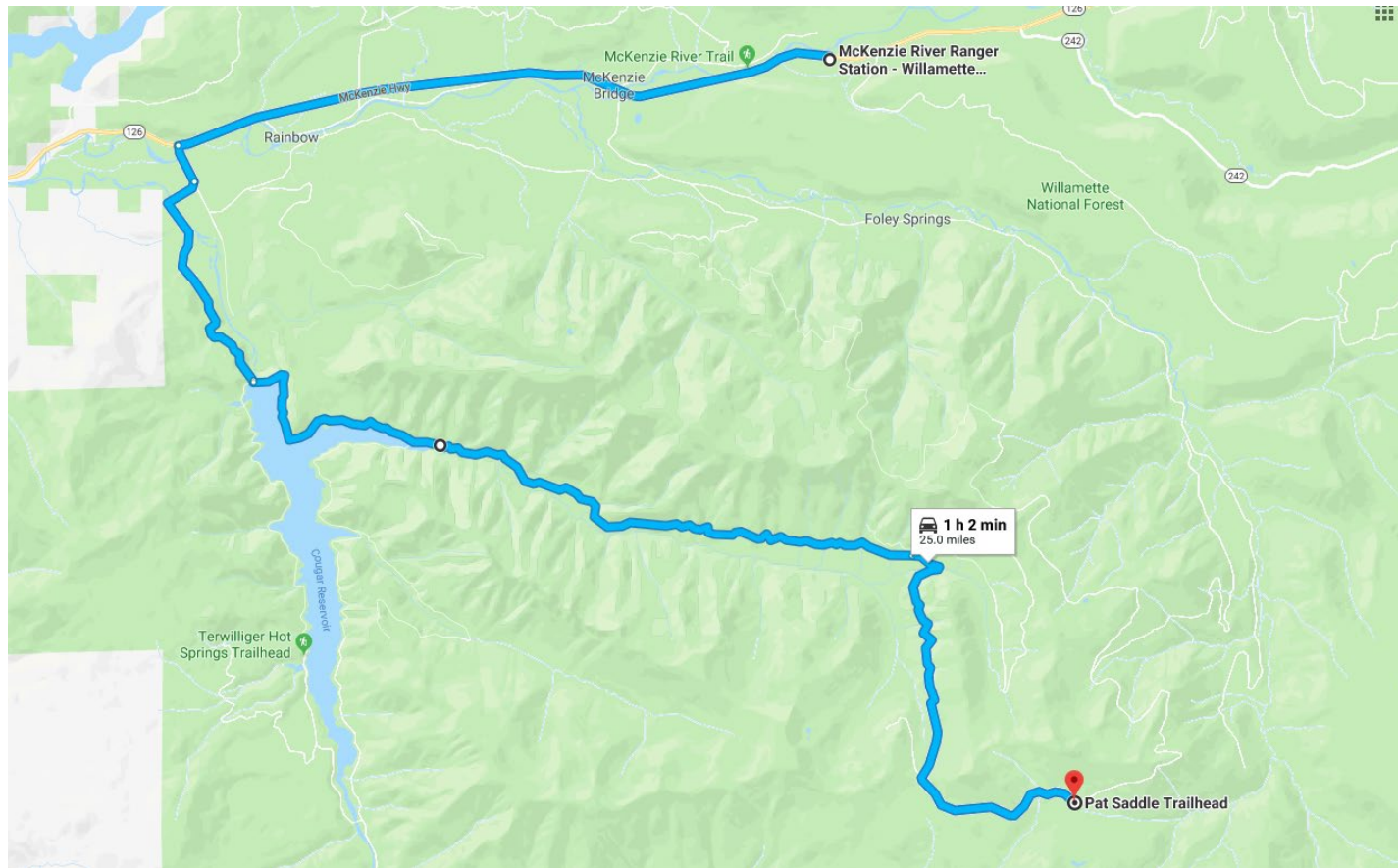

Route from Eugene to Pat Saddle Trailhead. Google Maps.

Trails

From the Pat Saddle Trailhead the lookout is reached by Olallie Trail #3529 and Olallie Mountain Trail #4100. The lookout's coordinates are approximately 44.028857, -122.068233. The route is 3 miles long and ascends from 5,425 feet at the trailhead to 5,700 feet at the lookout. The trail requires no substantial creek crossings. Water is available at Mosquito Creek approximately .5 miles from the trailhead along Olallie Trail. Campsites are located at the trailhead and at the top of Olallie Mountain, within 1/8 mile from the lookout; however, the lookout site is 2.5 miles from any water source. The lookout is on a wide flat ridge where all crew members could work effectively at one time.

Staging Materials

The recommended method for future work at Olallie Mountain would be a) a pack train from the Pat Saddle Trail or b) helicopter flights to a large meadow on the ridge north of the lookout.

Stock - The Pat Saddle Trailhead provides ample room for a horse trailer. The trail is likely to be very muddy in late June and early July. The last 1/4 mile of trail is steep with a narrow tread and steep drop-off that may be difficult if packs are heavy. A clearing near the lookout provides space to unpack the train, and/or turn the train around.

Helicopters - Staging areas were not identified during this assessment, but several clearings and parking areas near Cougar Reservoir could provide enough room. Pat Saddle Trailhead is not a feasible staging area. A former helicopter pad 1/8 mile north of the lookout is still an ideal location to deliver and retrieve. A helicopter could be landed in the case of an emergency evacuation.

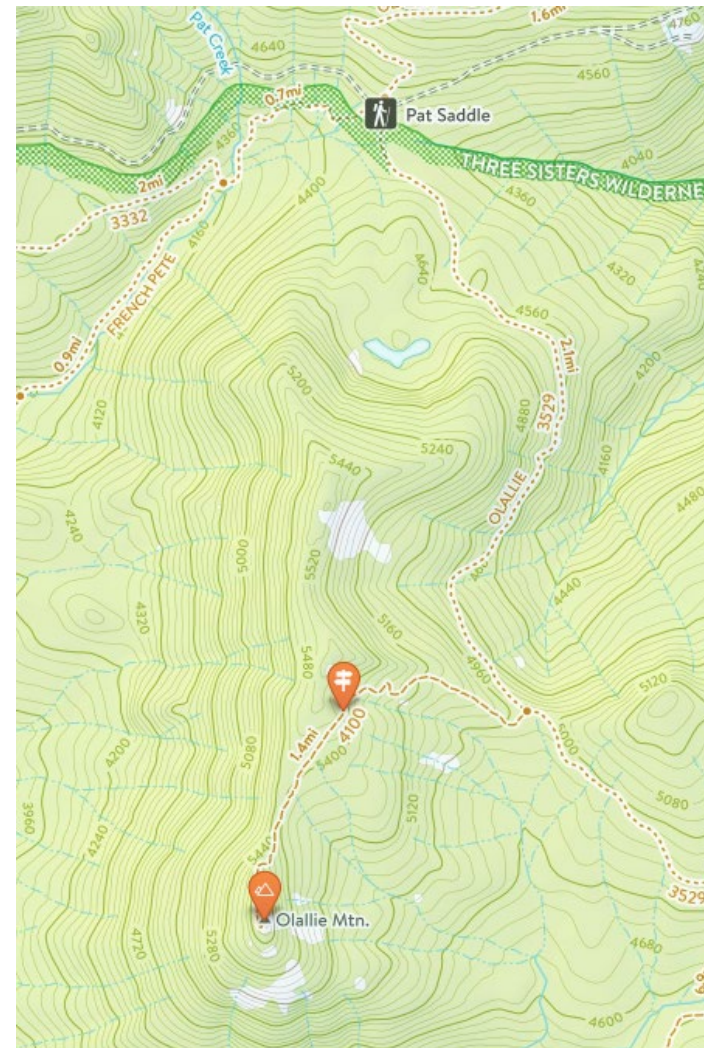

Pat Saddle Trailhead, Olallie Mountain Trail, and Olallie Mountain. www.naturalatlas.com.



Potential campsite and helicopter landing site within $\frac{1}{8}$ of a mile north from Olallie Mountain Lookout along the Olallie Mountain Trail

Rebel Rock Lookout

Three Sisters Wilderness, Willamette National Forest

Charlotte Helmer, HistoriCorps Principal Investigator

December 2017



Summary

Rebel Rock Lookout was located in the McKenzie River Ranger District of the Willamette National Forest and accessed from the Rebel Trailhead on South Fork Road (Forest Road #19), south of Cougar Reservoir. From the trailhead, the lookout site can be reached by either Rebel Rock Trail #3324 (to the south) or Rebel Creek Trail #3323 (to the north). If accessed from the Rebel Creek Trail, the route is at least 6 miles long. Alternatively, if accessed from the Rebel Rock Trail, the route is roughly 4 miles long. A roughly 1/8 mile long spur trail from the Rebel Rock Trail and lead to the lookout. The lookout's coordinates were approximately 43.9798, -122.1240. It perched on the edge of a cliff at an elevation of roughly 5,300 feet and provided sweeping views to the south.

The lookout was a single-story building on top of a rubble and concrete pier foundation with a footprint of 14' x 14'. It was of stud framed construction, clad in horizontal shiplap boards, and had a hipped roof clad in shingles. The lookout's most distinctive features were its continuous windows, catwalk, and awning shutters across all four elevations. A single door with windows was offset in the northeast elevation. Rebel Rock Lookout was constructed ca. 1955 and exemplified the L-4 "Standard 1936" ground house design which features a hipped roof and extended ceiling joists that support the shutters.

As of its assessment on Sunday, July 9, 2017 Rebel Rock Lookout was in poor condition. Its catwalks, windows, shutters, and roof were in poor-to-fair condition such that their deterioration would have accelerated within five years. Despite its poor condition, Rebel Rock Lookout retained a high degree of integrity in all seven of the characteristics that are typically considered: setting, location, craftsmanship, design, materials, feeling, and association. The lookout's foundation and structure were in excellent condition which preserved the opportunity to restore this building without a substantial reconstruction.

Rebel Rock Lookout was destroyed by the Rebel Fire in the summer of 2017, shortly after the following condition assessment was completed. The preservation treatments outlined in this report are no longer feasible, but it is still useful to have a detailed record of the physical condition and historical integrity of this lookout.

Rebel Rock Lookout, no date. USFS.



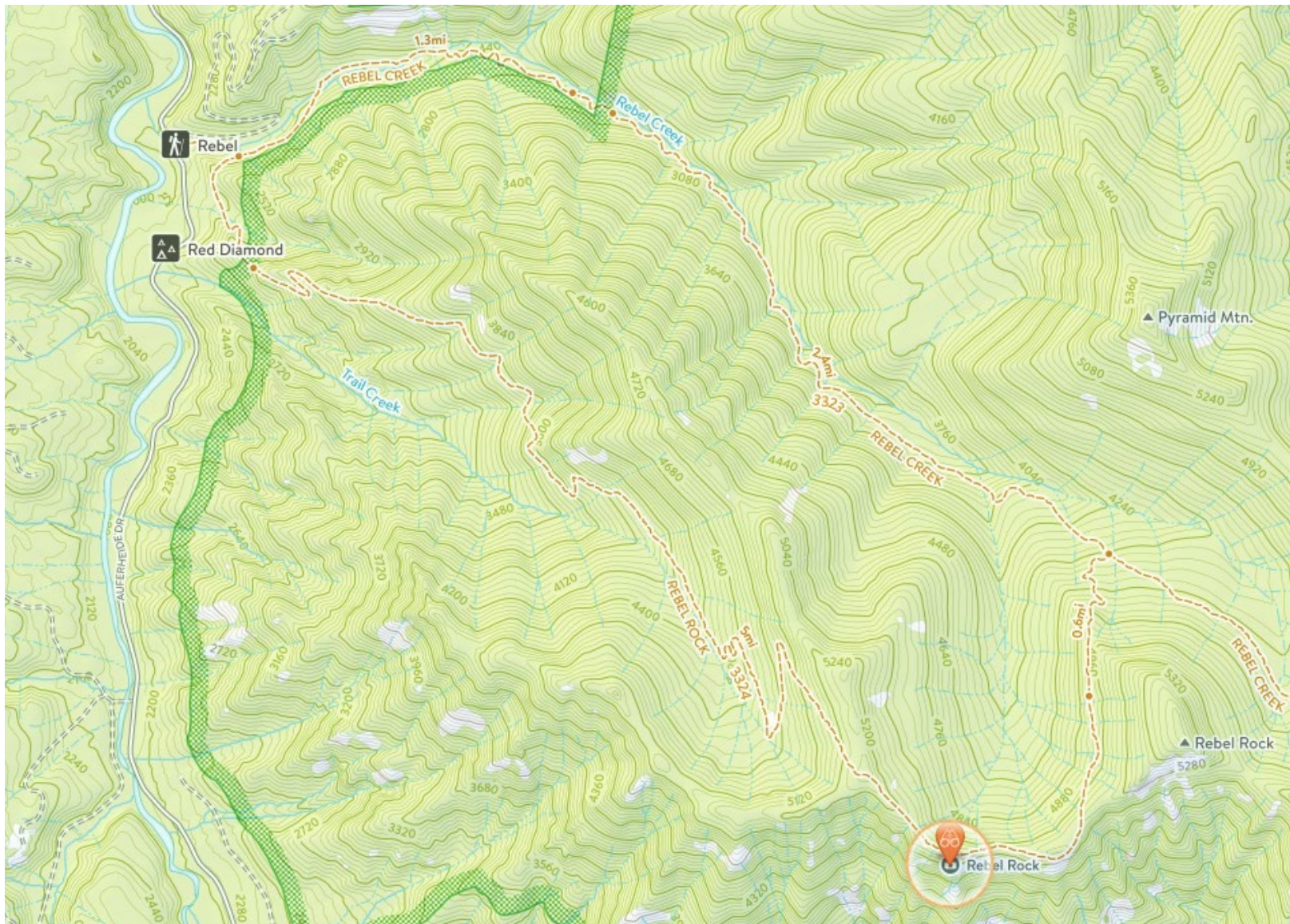

Map of Rebel Trailhead, Rebel Rock Trail #3324, Rebel Creek Trail #3323, and Rebel Rock Lookout site. www.naturalatlas.com.

Site

Rebel Rock Lookout is sited on a solid base of rock with steep slopes descending to the south. A detached latrine is sited north of the lookout and about 50' off the spur trail. It does not appear to be a significant historical feature. The spur trail leads directly to the lookout's front door and the northeast elevation where a small clearing provides the only flat open ground near the building.

Overall, the site is in good condition; common concerns such as overhanging branches, water runoff, erosion, and duff are not an issue. The site provides excellent drainage and ventilation for the lookout. Historical view-sheds are intact. No other built interventions are visible from the lookout. The only signs of alteration are old clear-cuts and an occasional airplane. Exposure is significant but not extreme and it primarily affects the southwest and southeast sides of the building.



Latrine



Small clearing and trail connection at the front door

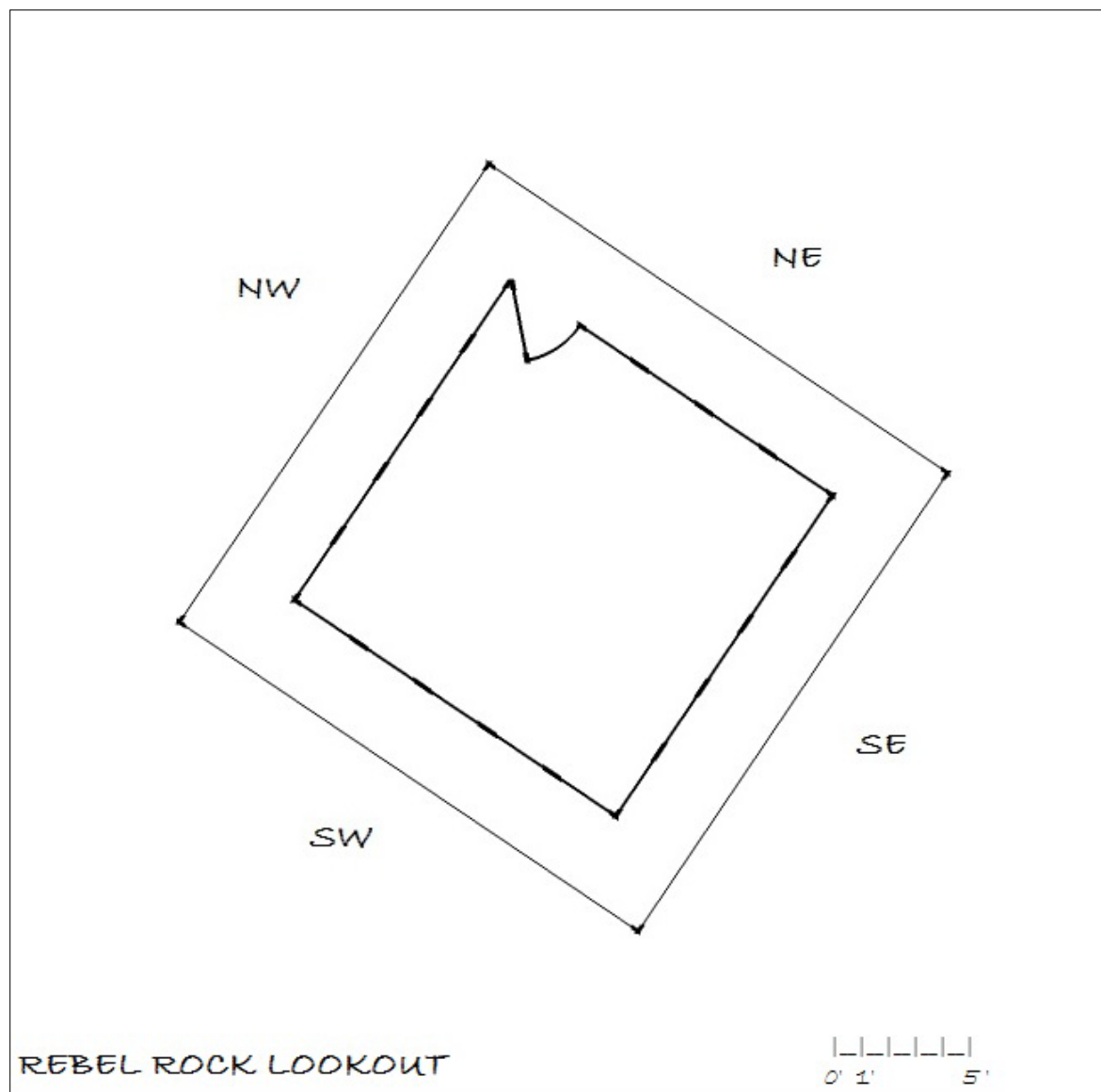

Exterior

Foundation - The foundation is in excellent condition. It is constructed of nine board-formed concrete piers 1' x 1' x 1' and taller depending on location. The concrete has large aggregate, clear seams, and some cracks. No crumbling, growth or other concerns. No indication of rebar. The joists are shimmed with large thin pieces of wood that appear to be cedar shingles.

Floor structure - The floor joists are in excellent condition except for two sections near the southwest wall that have been damaged by small fires that penetrated the floor and subfloor from above. The piers support three large joists, each comprised of three boards sistered together. Another set of three sistered joists runs perpendicular to the first level. A third set of smaller joists supports the subfloor above. These smaller joists are in good condition except for a 2' section and a 1' section that have been burned from above.



Typical construction and condition, southeast elevation

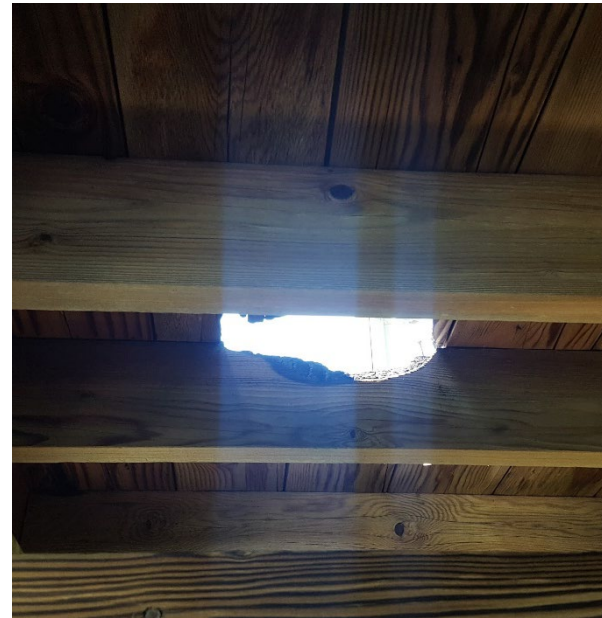

Burn damage, southwest corner

Catwalk - The catwalk surrounds the lookout cab on all four elevations and is in poor condition. The joists are in excellent condition, but the deck and railings pose a safety hazard. Several deck boards are missing and most others have been weakened by weathering, cracking, erosion, and UV damage. 75% need to be replaced. Railings are constructed with posts, diagonal braces at each corner, and two horizontal rails reinforced with a continuous panel of wire fence. The southwest and southeast side railings are rickety. The northwest side railing is broken. Its reconstruction would require two new posts, two rails, two diagonal braces, and one panel of wire fence. The northeast side railing is in poor condition and may have had a different design.



Missing deck boards, south corner



Erosion



Broken northwest railing



Altered northeast railing

Exterior siding - Each elevation is clad in four rows of horizontal lap siding over horizontal sheathing below a row of windows. The siding is in poor condition due to weathering, UV damage, cracking, and cupping. Siding boards are 5-1/4" wide with 5" reveal and a beveled profile. Siding could be replaced as follows: 100% of the southwest elevation, 50% of the southeast elevation, 25% of the northeast elevation, and 25% of the northwest elevation. A consolidant and paint treatments would extend the lifetime of any original material that is retained. On the other hand, if these treatments are not applied within 3 years it is likely that all siding will need to be replaced. The sheathing underneath appears to be in good condition, but if broken and missing siding is not replaced the exposed sheathing will begin to fail. Sheathing boards appear to have an 8" x 1" profile.



Typical construction



Typical condition

Exterior trim - Each elevation is trimmed with corner boards, baseboards, window aprons, window sills, and horizontal headers that support the shutters from above the windows. Overall, the trim is in fair condition. Most of the damage is concentrated on the south sides of the building where weathering and exposure are the most severe. The short corner boards are in poor condition, typically cracked, weathered, broken, or missing. These could be replaced throughout. One baseboard needs to be replaced. One window sill is cracked and needs to be replaced.

Exterior finishes - The lookout was previously treated with a light grey latex-based paint used inside and out. Weathering, UV damage, and exposure have stripped almost all paint from the exterior, particularly on the southwest side.



Typical construction



Corner boards



Shutter hinges

Shutters - The shutter system is in poor condition. Each elevation has two awning-style shutters constructed from a single layer of 1” thick horizontal tongue and groove boards reinforced with vertical and diagonal braces. The shutters are designed to hang suspended from rafters above. The shutters are screwed into exterior mullions with Philips-head screws. The screws render the shutters inoperable but likely have helped relieve weight and wear on the hinges. Most shutters are broken in half, and others are missing or otherwise damaged. Trail reports and public photographs indicate that the shutters have been broken in half for more than a decade. 75% of the shutters will need to be rebuilt. The remaining 25% need repairs. The shutter hinges and pins are in good condition. Pins are 5” long and have a square head (1” diameter) and a round shaft (½” diameter). At least four pins and six hinges could be replaced.



Typical construction (reinforced), northeast elevation



Typical condition, southwest elevation

Windows - Overall, the window system is in poor-to-critical condition. These elements are highly significant architectural features that define the lookout's historical character and function. They also serve a critical structural purpose by protecting the interior, walls, floor, and foundation from weather damage and keep the building secured. Rebel Rock Lookout has 19 four-lite windows. Three elevations have five windows and the northeast elevation, which includes the front door, has four windows. Three operable windows at the center of three elevations are designed to open out. The rest are fixed casements held in place by quarter-round pieces of horizontal trim. Exterior mullions are consistently in fair condition with some damage from weathering that could be mitigated with an applied consolidant. Interior mullions are in good condition. Each sash is in good condition, but most need to be repainted. Muntins are constructed with one continuous horizontal piece and two vertical pieces. Approximately 20% of the muntin pieces are broken or missing. Panes of clear plate glass are installed with diamond-shaped points and putty. 75% of window panes are missing, broken, or cracked. Most glazing putty is missing or damaged. Hardware on the operable windows is all in good condition, although one header could be reinstalled to allow the hinge to move.



Exterior mullion and sash profiles



Interior sash and muntin profiles



Hinge and detached header



Typical construction of operable and fixed casement windows



Windows in poor condition, with broken panes and muntins

Door - The lookout's single door is on the northeast elevation. It appears to be original and is in good condition with panes, muntins, panels, and hardware intact. A small amount of damage to the woodwork could be patched with wood filler and the door could be repainted. It does not have an external lock.



Construction, hardware, and condition

Outriggers - Shutters are held open in an awning position suspended from outriggers that protrude above the windows. All these outriggers appear to be in good condition but were not all accessible during this assessment. Furthermore, it is likely that the shutters have not been opened and suspended from the outriggers in several years. Trail reports and public photographs indicate that that shutters have sometimes been left open and collected several inches of snow in the winter. Snow loads place an unintended and unnecessary strain on the shutter system which can be avoided by securing the shutters before winter. If the shutters are repaired the outriggers may still support their weight but this can be readdressed when the shutters are installed and/or the roof is replaced. Several small superficial fascia boards between these outriggers are missing.

Roof cladding - The hipped roof was not accessible during this assessment but appears to be in critical condition. It has an estimated slope of 9/12 and is clad in cedar shingles with a 5” reveal. All shingles are ready for replacement.



Typical construction and condition of external rafters and shingle roof.

Interior

Floor - The floor and subfloor are in fair condition except for two sites where holes have been burned through the floor, subfloor, and joist from above. The floor and subfloor require repairs in two patches measuring 1' x 3' and 2' x 2'. Otherwise, the floorboards are worn and pitted by a pest infestation which has not affected the structural integrity of the floor. A piece of furniture, likely an Osborne Fire Finder, was formerly installed in the center of the room and has since been cut out. It appears that the floorboards were never painted. An application of varnish would protect the floor without significantly altering its original appearance and might be a worthwhile intervention.



Typical construction and condition, absent Fire Finder



Burn damage (1' x 3')



Burn damage (2' x 2')

Walls - The wall structure, cladding, trim, and finishes are in good condition overall. The lookout is likely framed in studs aligned to the window mullions. The structure was not accessible but appears to be in excellent condition. Walls are clad in four rows of horizontal boards and formerly treated with a light grey latex-based paint. Lead content was not tested during this assessment. All boards are intact. Almost all paint has faded and weathered away, especially on the southwest end of the building where weather and UV exposure are the most severe. A new coat of primer and paint will be sufficient to protect these features. Quarter-round trim around the floor and ceiling; window sills, headers, and mullions are all in good condition. Window sills in the east corner have been roughly cut to fit around furniture. If furniture is removed it may be appropriate to replace the sills. Headers above the windows on each wall exhibit some graffiti in pencil and carving. These marks can be painted over and concealed with a small application of wood-filler. They do not necessitate replacing the damaged boards.



Typical construction



Typical condition

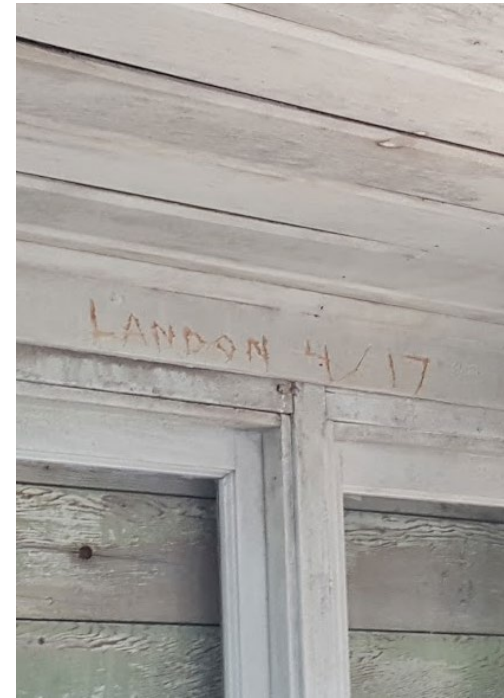

Carved graffiti damage

Ceiling - The ceiling joists, cladding, and treatment are in fair condition. The ceiling joists were mostly inaccessible except where they can be seen through an attic hatch. They appear to be in excellent condition. Ceiling boards exhibit some staining (likely from smoke) and need to be secured to the ceiling joists where nails have back-out through a freeze-thaw cycle that has likely had a greater impact on the interior since windows were broken and shutters were removed. The ceiling is treated with the same light grey latex-based paint used throughout the building. It is in fair condition.

Roof structure - The attic was inaccessible during this trip but rafters and sheathing were partly visible through the attic hatch. The attic appears to be uncluttered and well ventilated. The roof structure is in excellent condition, despite the poor condition of shingles above. Light through the sheathing boards indicated that the roof has no moisture barrier, or the barrier is failing.



Typical ceiling construction and condition



Roof construction and condition

Additional Features

Mechanical Systems - The lookout’s only mechanical system is an uncovered stove pipe and disconnected stove. There are no artificial lighting, ventilation, plumbing, or fire suppression systems. A lighting rod, copper cap, and four grounding wires are installed on the roof. An old telephone line and ceramic insulators remain as evidence of a phone system that was used when the lookout was active. The wire is down along the trail and insulators are suspended from trees periodically along the Rebel Rock Trail.

Furniture - The lookout contains a desk and two cabinets built from lumber and plywood. The desk is in fair condition. The cabinets are in poor condition. These may be original features of the interior but are not as significant as other furniture, such as an original Osborn Fire Finder would be. The furniture can be repaired and left in place.

Trash - The site and interior are strewn with branches, broken glass, tarps, canvas sheets, a broom, a broken bow saw, a damaged tent, and other trash. This condition encourages other visitors to leave their trash behind and/or damage the interior. It also encourages animals and insects to occupy the building. Finally, this debris traps moisture, stains and scratches the interior. Trail reports and public photographs indicate that the interior was clean and tidy five years ago.



Disconnected stove



Furniture and debris



Trash

Security - The building is not secured against animals or trespassers. Trespassers can enter through the door and windows. Animals can enter through holes burned in the floor, windows, and the uncovered stovepipe. Animals and people have access to the attic as well. In the short term, broken windows can be secured with plywood but considering the logistical challenge of bringing materials to this remote site it might be more efficient to rebuild the shutters as a means of securing the lookout.

Safety - The lookout is not safe for visitors but its hazards should be obvious to anyone who arrives at the site. It does not pose any hidden structural concerns. The catwalk boards and railings are minimally strong enough to support a person walking around the outside and would likely break if someone fell into the railing. Broken glass creates a slipping hazard on the catwalk. Rodent droppings and trash inside the lookout create a potential harm from Hanta virus and tetanus.

Onsite Tools and Materials – Approx.3 feet of metal flashing and several floor joist boards are stashed below the lookout.



Weathered catwalk, broken glass, and broken windows on the southeast elevation

Red's Horse Ranch

Eagle Cap Wilderness, Wallowa-Whitman National Forest

Charlotte Helmer, HistoriCorps Principal Investigator

December 2017



Recommendations

Red's Horse Ranch is unlike any other site included in this broad scale assessment of heritage resources across the state of Oregon because it is a district comprised of multiple buildings and landscape features, and it was developed by private owners for a commercial use rather than as a Forest Service administrative site. It is alternatively known as "The Horse Ranch" and "Red's Wallowa Ranch." In 1994, Red's was acquired by the Wallowa-Whitman National Forest for inclusion in the Eagle Cap Wilderness. The ranch is sited at an elevation of approximately 3,600 feet near the Wild and Scenic Minam River. The site can be accessed by hiking approximately 7.5 miles from the Moss Springs Trailhead, east of Cove, Oregon.

As of its assessment in late August, 2017 Red's Horse Ranch is in fair condition and has a significant level of public engagement. The complex retains a high degree of integrity in all seven of the characteristics that are typically considered: setting, location, craftsmanship, design, materials, feeling, and association. Individual buildings that are non-contributing features have been removed, and most primary features have been preserved. HistoriCorps recommends preserving the barn, milking shed, and bunkhouse #2 in order to maintain the historic integrity of the ranch, even though they have a limited administrative use. The kitchen / dining hall (also called the lodge) are also important because it is the center of public and administrative functions at the ranch. Red's Cabin and all unused guest cabins have high potential for adaptive reuse, except for their inclusion within wilderness. Forest Service personnel could consider adding some or all of these buildings to the cabin rental program (which would certainly require a Minimum Requirements Analysis) or make them available to caretakers and expand the caretaker program.

According to volunteer caretakers who were on site during this assessment, Red's Horse Ranch is typically open from early May to late November and is staffed by volunteers who stay for one week at a time. Potential caretakers typically wait several seasons before a spot becomes available, and they are not permitted to stay longer than one week. In short, the ranch attracts public attention that surpasses the capacity of existing programs that allow visitors to access and engage these historic resources.

The ranch is opened and closed by the same caretaker at start and end of each season. Caretakers do not maintain trails but do mow lawns, greet visitors, and conduct maintenance projects. The airstrip is mowed with a mule team each season. This is done by a commercial outfitter from Moss Springs in cooperation with the Minam River Lodge, a private inholding. Most caretakers and visitors arrive on foot or by horseback from the Moss Springs Trailhead. They can also be transported and supplied by chartering a commercial flight from Enterprise and landing on the air strip at Red's. Visitors are permitted to camp at the south end of the air strip and on small plateaus between the Ranch and the Minam River, but they may not camp within the ranch district.

A private inholding called the Minam River Lodge has recently been developed in the Minam Valley, northwest of Red's Horse Ranch. Like Red's, it has an airstrip, a lodge, a barn, and roughly a dozen cabins. Approximately fifty guests stayed at the Minam River Lodge over Labor Day weekend in 2017. Most guests flew in via the Minam River Lodge's airstrip and had come from Portland, Oregon. The

newly reopened luxury lodge will likely increase traffic in the Minam Valley. Furthermore, its success indicates that Red's could have a similar following if it were made available to the public via the cabin rental program or an expanded caretaker program. This finding is speculative and could be explored in greater detail by consulting the owner-operators of Minam River Lodge.

Red's Horse Ranch is an intriguing site that demonstrates successful collaborative management strategies between the Forest Service, commercial enterprises, and a dedicated community of public volunteers. Furthermore, Red's represents a clear opportunity to improve the condition of a historic resource by expanding those collaborative relationships and investing more resources in the property. Since the Forest Service acquired this property in 1994 it has dutifully documented the site and maintained parts of it through a minimal caretaker program. However, some of the structures have been altered through benign neglect and there is no active preservation program in place that indicates this trend will change in the future.

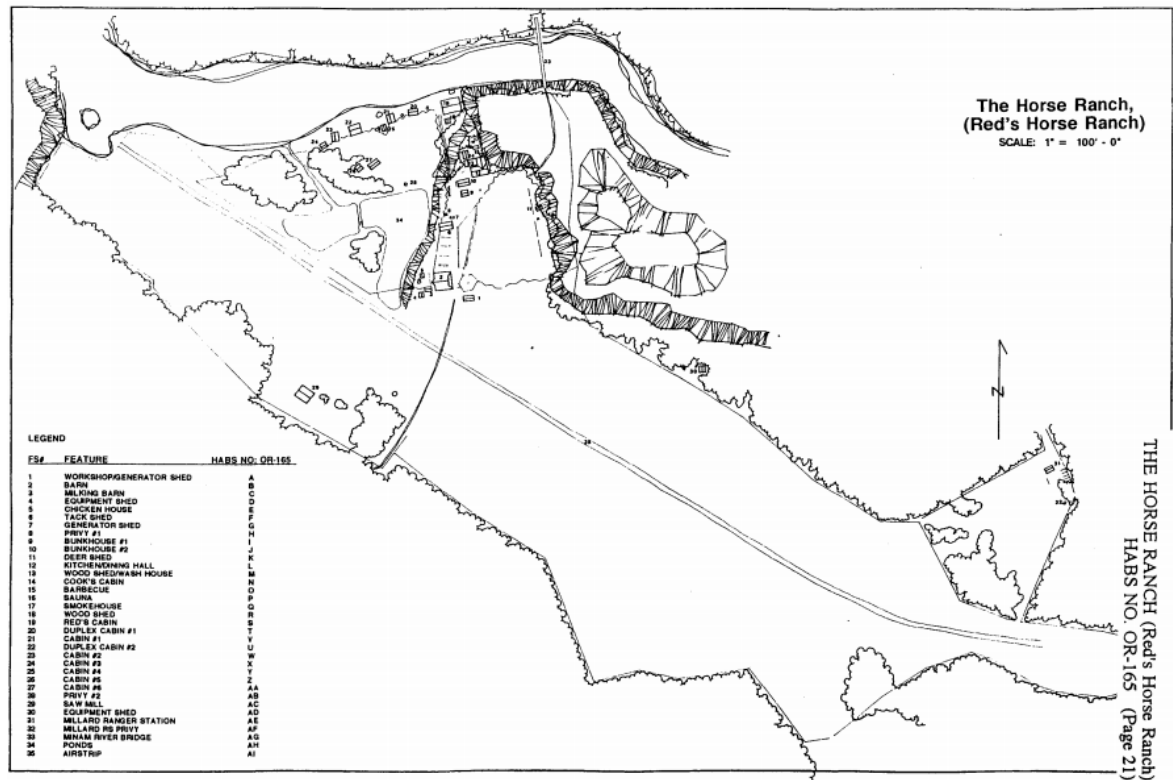

Site plan of Red's Horse Ranch, 1994. Library of Congress.



View of west back of barn, facing east; 1994, 2017



View of south side of milking barn, facing north; 1994, 2017



Original portion of the Kitchen/Dining hall



Kitchen amenities



Dining hall ceiling condition



Red's Cabin: exterior



Red's Cabin: interior



Guest cabins: exterior



Guest cabins: interior

Overview Assessment and Recommendations

FEATURE	SIGNIFICANCE	CONDITION	URGENCY	NOTES
Barn	primary	poor	critical	The barn (ca. 1912) was damaged by a storm and stabilized with an elaborate series of cables. Further stabilization and restoration are highly recommended.
Milking barn	primary	poor	critical	In 1994, the milking barn (1931-1947) retained interior features such as the stanchions and concrete trough. It has collapsed and may merit reconstruction.
Kitchen/Dining Hall	contributing	poor	critical	This building has been adaptively maintained and is used by caretakers. It is the center of public and administrative functions at the ranch. It can sustain minor alterations that assist administrative functions and merits further assessment. Update the interpretive materials and lighting in the oldest part of the lodge. Update plumbing and repair the restrooms. Repair damage to the dining room ceiling and investigate moisture issues in roof structure. Replace carpet and linoleum. Appliances appear to be in good condition.
Bunkhouse #2	primary	fair	urgent	The second bunkhouse (1910s) is used as a tool shed. Replace missing log and daubing; Restore windows. This building could be added to the cabin rental program or used to house more volunteer caretakers. It merits further assessment and consideration.
Red's Cabin	contributing	fair	urgent	Red's Cabin (1946) is the largest of all the cabins and is the third largest building on the site. It functioned as a residence, guest facility, and gathering place. It could accommodate six guests on the main floor and many more in the large upstairs rooms. The overall design is typical of those featured in various log construction plan books. This is a functional building that the caretakers have a special

				interest in. It has high potential for adaptive reuse. Consider adding it to the cabin rental program (which would certainly require an MRDG) and making it available for caretakers to use. It merits further assessment and consideration. Most systems would need to be addressed, including plumbing, electrical, the fireplace, potential water damage in the roof, kitchenette. Rear steps are unsafe and could be rebuilt (even if the cabin remains closed).
Duplex Cabin #1	contributing	fair	urgent	Duplex Cabins #1-2 (1946) and Cabins #1-2 (1947) are typical of those featured in various log construction plan books. Cabins #3-6 (1930s) functioned historically as a bunkhouse for packers when the ranch was an active outfitter guide operation. All of these cabins have high potential for reuse and could be added to the cabin rental program or used to house more volunteer caretakers. Repair daubing, sill logs, and windows. They merit further assessment and consideration.
Duplex Cabin #2	contributing	fair	urgent	
Cabin #1	contributing	fair	urgent	
Cabin #2	contributing	fair	urgent	
Cabin #3	contributing	fair	urgent	
Cabin #4	contributing	fair	urgent	
Cabin #5	contributing	fair	urgent	
Cabin #6	contributing	fair	urgent	
Bunkhouse #1	primary	good	minor	The bunkhouse (1910s) has been well preserved and is used by caretakers.
Tack shed	primary	good	minor	The tack shed (1930s) appears to be in good condition but may need closer inspection. It could be preserved.
Wash House	primary	good	minor	(ca. 1946)

Cook's Cabin	primary	good	minor	(ca. 1946)
Bridge	primary	good	minor	The bridge (reconstructed in 2004) can be preserved with cyclic maintenance
Airstrip	primary	good	minor	The airstrip (1930s) is a highly unusual feature that greatly improved the ranch's commercial viability and makes it more significant.
Barbeque	contributing	good	minor	(1965)
Saw Mill	non-contributing	poor	minor	The sawmill (1960s) was in poor condition in 1994 and has since collapsed. It could be removed or left alone.
Smokehouse	non-contributing	fair	minor	
Sauna	non-contributing	good	minor	
Ponds	non-contributing	good	minor	
Generator shed	non-contributing	good	minor	
Privy	non-contributing	good	minor	
Demolished Outbuildings	non-contributing	removed	n/a	The chicken house, deer shed, two equipment sheds, privy, woodshed, and workshop / generator shed were all non-contributing structures that were thoroughly documented via HABS and then removed.

Timberline Trail Shelter System

Mount Hood Wilderness, Mount Hood National Forest

Charlotte Helmer, HistoriCorps Principal Investigator

December 2017



Summary

The Timberline Trail and its associated buildings circumnavigate Mount Hood at the timberline and were constructed by the Civilian Conservation Corps from 1933-1935. It crosses into several districts of the Mount Hood National Forest, and most of the system is located within the Mount Hood Wilderness. According to a National Register nomination written by Gail Throop, stone shelters were built at Paradise Park, McNeil Point, Cairn Basin, Elk Cove, Cooper Spur, Gnarl Ridge (a.k.a. Lamberson Butte), and Mitchell Creek (a.k.a. Mount Hood Meadows) and wood shelters were built at Ramona Falls, Elk Meadows, and Bald Mountain. All were intended to provide relief for small parties during severe storms. As a general pattern, wood shelters were built below the timberline. Stone shelters were sited above the timberline where a scarcity of firewood necessitated an “indestructible” design that hikers would not dismantle. None of these shelters exactly follow the Forest Service’s standardized design; each is a variation on the original specifications.

Today, the four shelters are extant and six are in ruins. Of all the collapsed stone shelters on the Timberline Trail, Gnarl Ridge Shelter is the most substantial ruin. It may be feasible to stabilize the remains of Gnarl Point Shelter but its characteristic features are unrecognizable. The ruins have minimal potential as interpretive sites because they will only be understood by visitors who have seen the extant shelters at Elk Meadows, Cairn Basin, McNeil Point, and Cooper Spur. Reconstruction of the ruined shelters is not recommended under any circumstances.

The surviving shelters exhibit a range of conditions from good to critical. McNeil Point Shelter needs critical repairs and is recommended as a management priority. Cairn Basin Shelter also needs urgent attention. Cooper Spur Shelter is in the best condition, but alterations to its roof and doorway have impacted several characteristics of historic integrity that are better represented by the shelters at McNeil Point and Cairn Basin. Elk Meadows Shelter needs urgent repairs that may entail reconstruction. All proposed actions are dependent upon the forest’s management decisions and the MRDG process.

Timberline Trail Shelters

		Extant	Demolished
Masonry	Log	<i>Elk Meadows</i>	<i>Bald Mountain Ramona Falls</i>
		<i>Cairn Basin Cooper Spur McNeil Point</i>	<i>Elk Cove Gnarl Ridge Mitchell Creek Paradise Park</i>

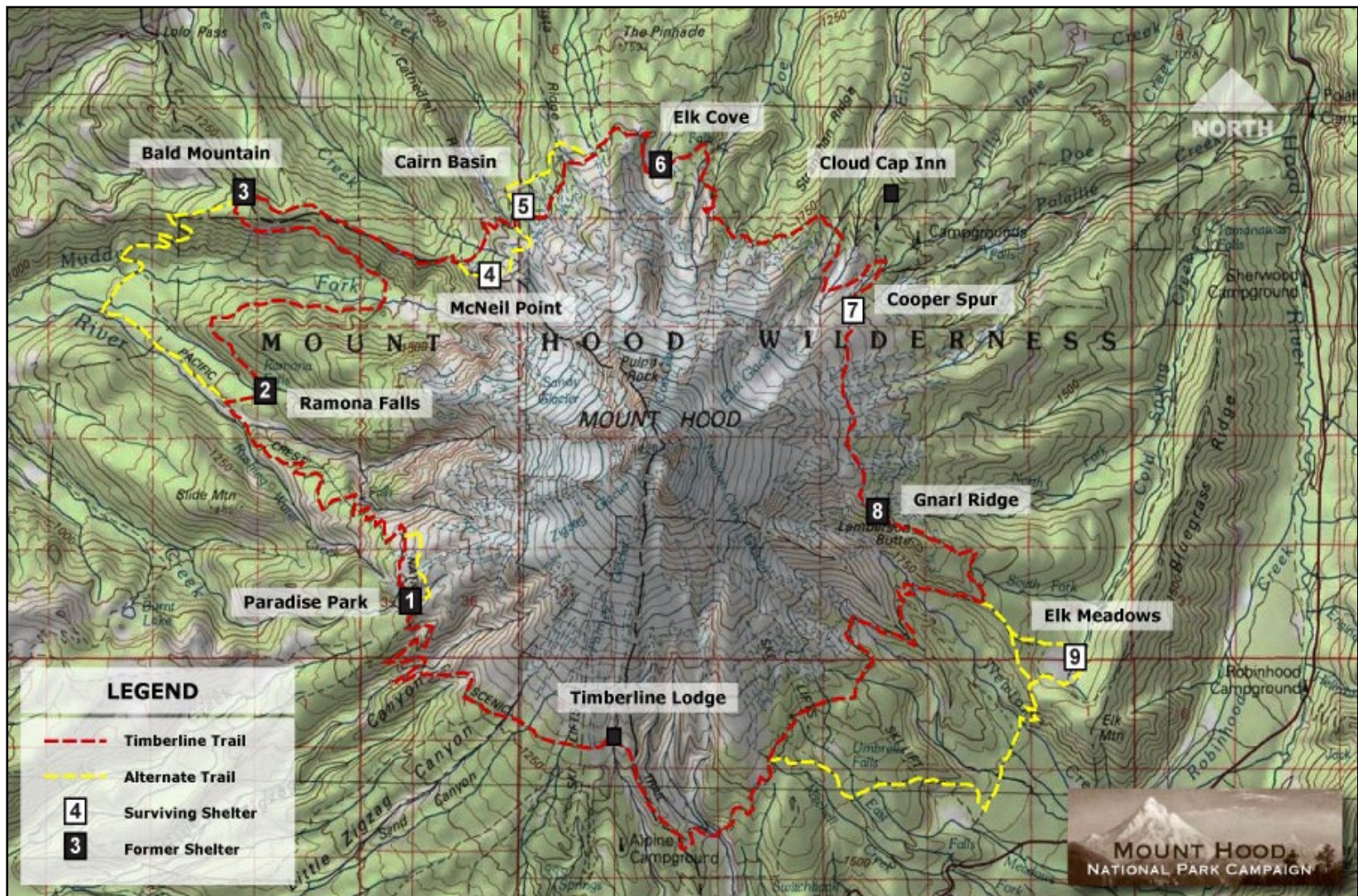

Timberline Trail Shelters [#10: Mitchell Creek is absent], Timberline Lodge, and Cloud Cap Inn. Mount Hood National Park Campaign, 2010

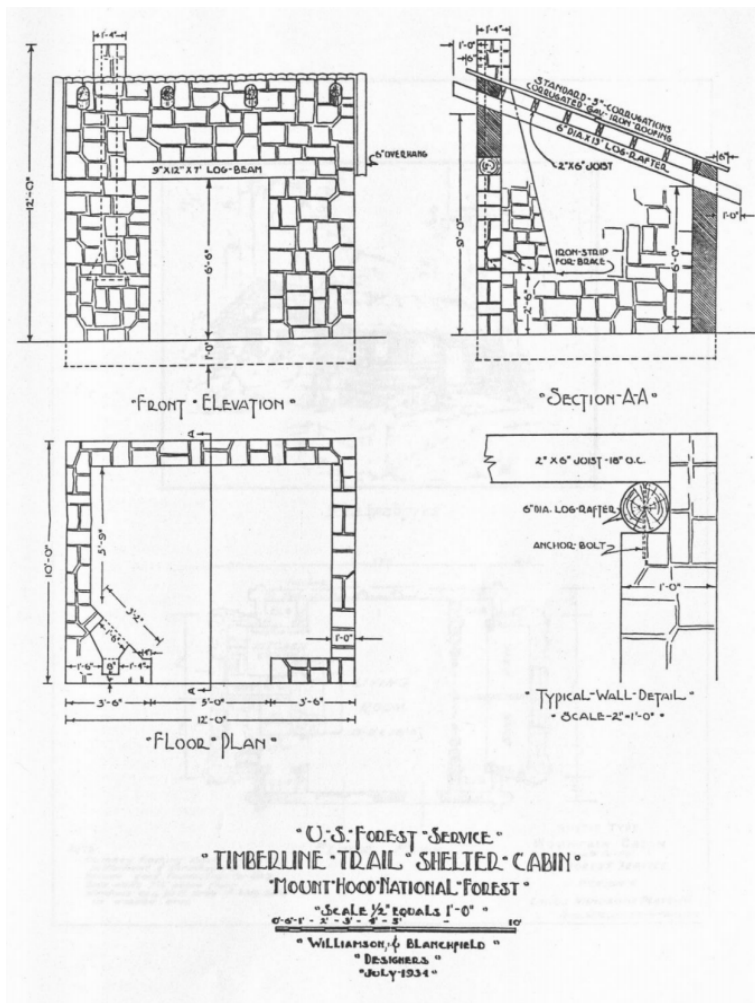

1934 Timberline Trail shelter plan

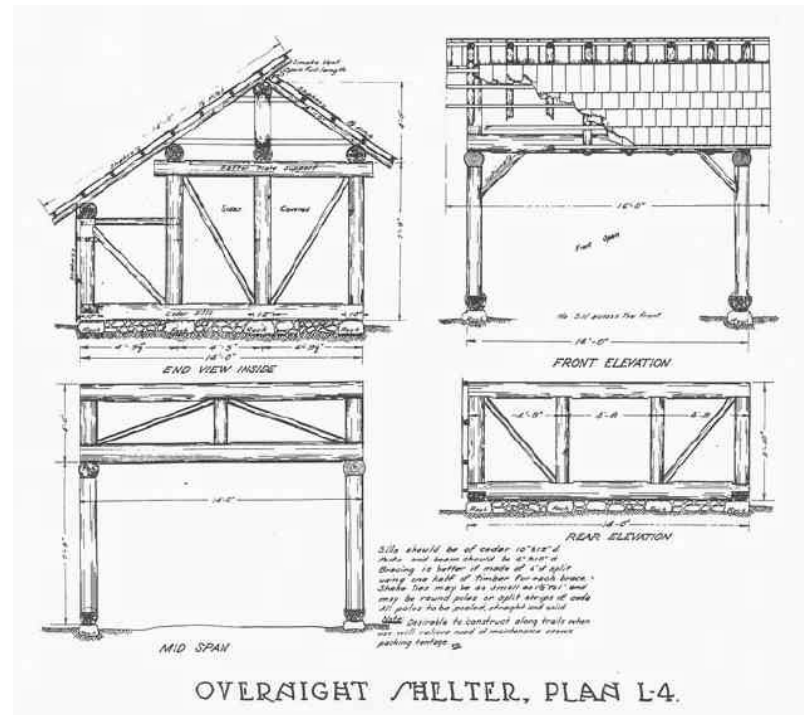

1934 USFS Region 6 trail shelter plan

Elk Meadows Shelter

Site - Elk Meadows Shelter is sited at the edge of Elk Meadows and is tucked into the tree line where it faces west across the meadows, towards Mount Hood. Compared to the other extant shelters, Elk Meadows Shelter is at low elevation which protects it from severe weather conditions. However, the log-built shelter sits on soft soil that retains moisture and it is surrounded by trees and other plants that build up a thick layer of duff on the ground. All significant damage that this shelter has sustained originated from the site conditions. Moisture in the ground has rotted the sills and posts, and a fallen branch has cracked the roof structure. Once the building's critical structural issues have been repaired, site maintenance will be the key to retaining that progress in the future. Several hazard trees surround the shelter and pose a risk of damaging it. *Recommended Treatment:* rake plants and duff away from the shelter walls to keep the sills relatively clean and dry; remove hazard trees and overhanging branches, if it is feasible to do so.

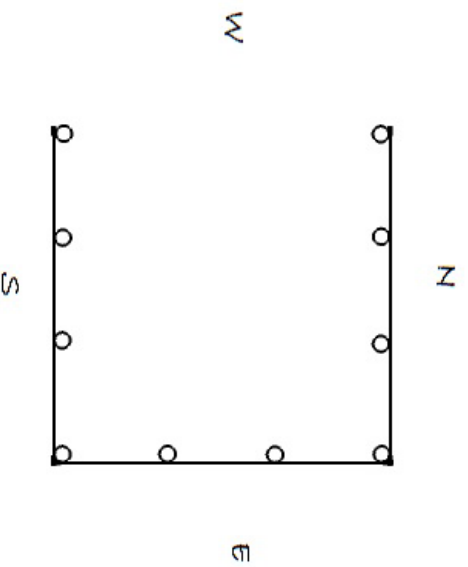

Plan



Site conditions, north and west elevations

Sills - The shelter has a 14' x 14' footprint and is framed in logs that rest directly on the ground. Each sill is notched on top to hold the butt end of posts which are toe-nailed to the sills. The sills are joined with laps such that the east and west sills which support the side walls fit on top of the south sill which supports the rear wall. All sill logs have disintegrated and they must be replaced. Lacking sills, the shelter has racked and several posts rest directly on the ground where they wick moisture, which has accelerated decay. The existing sills have disintegrated to the degree that their exact measurements cannot be salvaged. *Recommended Treatment:* replace the east, west, and south sills; trim and notch each log as is necessary to square-up the building.

Posts - The shelter walls are framed in logs and clad in a mixture of cedar shakes and shingles. Eight of the ten posts have rotted where they meet disintegrated sill logs or directly touch the ground. Sills are causing posts to come out of alignment. Several posts are racked. The northeast corner has sunk by roughly 6" to 1'. The west posts have tipped such that the top ends have shifted west and the bottom ends have shifted east. The shelter has racked forward but its side walls are still plumb. Graffiti is extensive across the posts and beams, and it is irreversible. *Recommended Treatment:* replace each post in full or repair them by cutting off the rotten sections and splicing in new sections using scarf joints about 1' high.



Typical condition of sills and posts demonstrated by the northeast corner and the rear wall

Beams - The shelter has four beams that run east-west and support the rafters. The south beam is rotted and has cracked directly above a post. The second beam is sound. The third beam-- the ridge pole-- is rotted all along the top. The fourth beam is located at the front of the building and has a small amount of rot at the northeast corner where shakes are missing from the roof. *Recommended Treatment:* replace the rear beam in full or replace a section of the center to preserve original notches on the ends. The replacement section could be spliced and joined with an under squinted joint and pegs. Replace the ridge beam in full. Retain the front beam for the time being, as long as the roof is repaired promptly.

Wall structure - Each wall is reinforced with two knee braces and several horizontal braces between posts. All braces are roughly 5' long and 4" in diameter. Knee braces were originally toe-nailed into the sill logs and many have dropped as the sills failed, leaving a 1" gap at their connection with the posts. Their lower ends have rotted along with the sills. Each of the side walls has seven horizontal nailing strips made of straight branches that bridge the gaps between posts and support shakes on the exterior. Additional nailers are attached to each sill to support the bottom of the first shake course. Rafters are trimmed with another set of nailers that support the top of the last shake course. *Recommended Treatment:* either reinstall braces or replace them once the sills have been replaced; replace missing nailers to reinstall shingles and shakes.



Condition of cracked rear beam



Condition of north wall braces

Roof structure - Elk Meadow Shelter has a modified gable roof, similar to a saltbox roof, but the east roof extends above the ridgeline by roughly 2'. The roof rises from 4'9" tall at the rear wall, to 10'10" at the peak, and drops to 7'6" at the entrance. The roof is built from pole rafters and nailers made from both poles and nominal 2x4 lumber. A fallen branch has damaged one rafter tail and one nailer on the east end of the ridge. 6' long 2x4s were used to reconstruct the east side of the roof and an unknown date, and are not historically accurate. This nominal lumber was not installed until sometime after 1978, because the original pole nailers are visible in USFS photos from that year. The north side of the roof retains its original pole structure to this day. Several of the 2x4 nailers are cracked along the nailing pattern that holds them to the rafters. The damage probably occurred when they were installed, and they can be retained for the time being. *Recommended Treatment:* repair the broken rafter tail with a scarf joint, and replace the broken 2x4 nailer. When the current roof begins to fail, it could be replaced with an accurate reconstruction of the original design. The north side of the roof, and maintenance records, can be used as a reference for that reconstruction.



Construction and condition, 1978. Courtesy of USFS.



Roof construction and condition

Shakes and Shingles - The walls of Elk Meadow Shelter are clad in a mixture of shakes and shingles. The shelter's front wall is open and there is an open doorway on each side wall; all other surfaces are clad. Historical photos show that the knee braces above the side doorways were typically clad in shakes, not exposed as they are now. It is likely that shakes were originally used and that they have been gradually replaced with large shingles in a series of maintenance projects. The first course of shakes and shingles is buried in the ground and rotted. These need to be above grade in the future, as has been mentioned. The roof is clad in shakes. These have weathered, especially at the northwest corner of the building which is the most exposed. All shakes are in good condition on the roof's southwest quarter and the east side. Sections of the roof and walls present two types of construction, directed by the density of shingle and shake courses. The walls and the east side of the roof are clad in 30" shakes with a 20" reveal, installed on nailers that are 20" apart (measured on center). The west side of the roof is clad 30" shingles with a 24" reveal, and nailers are 2' apart (measured on center). It is likely that when the east side of the roof was reconstructed using 2x4 nailers, the siding pattern was also changed to match the walls. Again, the west side of the roof is probably historically accurate and can serve as a template for any potential reconstruction project that might restore the historical integrity of the east roof. *Recommended Treatment:* In the short term, or as materials allow, the walls can be repaired with shingles. For historical accuracy and a complete restoration, all shingles could be removed and replaced with shakes.



Shingles and shakes, south wall



Roof construction: poles, replaced 2x4s, courses

Gnarl Ridge Shelter

Gnarl Ridge Shelter has collapsed and is now a ruin of rough stone walls. The shelter originally faced north toward the Timberline Trail #600 which passes by within 20’ of the shelter. A steep rocky slope rises behind the ruin on its west side. Like the other shelters of this type, Gnarl Ridge Shelter has a 14’x14’ footprint with walls about 1’ thick built from uncoursed rubble. Today, the front and side wall are partially intact while the rear wall and its corners are entirely collapsed. The remaining walls achieve a maximum height of 41” at the northwest corner and 44” at the northeast corner. The side walls have collapsed to the east, meaning that the upper half of the west wall is now spread inside the building’s footprint while a large segment of the east wall is scattered outside the footprint. The front and rear walls have collapsed to the north in a similar manner. These walls are in poor-to-fair condition. Mortar is failing and masonry units are loose, particularly along the top of each wall. These loose rocks are unlikely to fall on their own but could easily be knocked down by visitors to a height of about 30”. If the ruin is stabilized these walls will require repointing. For interpretive purposes, fallen stones that fill the interior could be removed to essentially clean up the site and make the walls and footprint more apparent. The chimney and fireplace are essentially unrecognizable. They appear as a slightly thicker wall section at the northeast corner. The roof is also gone: no rafter pieces remain, but a piece of corrugated steel lies on the ground within 50’ of the east side.

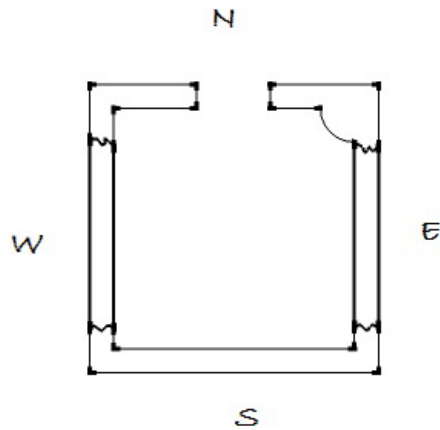

Plan



Site condition



Corrugated steel roof panel

Among the seven characteristics of historical integrity that are usually considered, this ruin retains integrity of setting and location but all other characteristics are compromised. Many of the shelter's original features are now unrecognizable. The facade, roof construction, chimney, and fireplace have essentially been erased. The building's original footprint and rough-coursed masonry construction are all that remains in terms of physical evidence. However, anyone who has seen the intact shelters at McNeil Point, Cairn Basin, or Cooper Spur will clearly recognize that Gnarl Ridge had a similar form. Details such as the fireplace, chimney, and lintel can be observed by those who know to look for them. In conclusion, the ruin of Gnarl Ridge Shelter has poor integrity when considered as an individual site but it does retain some integrity in aspects that could contribute to the broader context of the historic Timberline Trail and its associated buildings.

Recommended Treatment: Gnarl Ridge Shelter could be left as is, or at most repointed to preserve its current state. Reconstruction is not recommended under any circumstance.

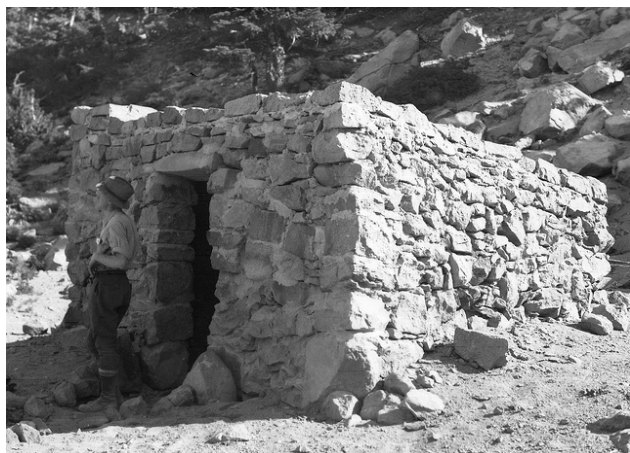

Gnarl Ridge Shelter, no date. OregonHikers.org.



Gnarl Ridge Shelter, 1978. USFS.



Gnarl Ridge Shelter, 2017

Cairn Basin Shelter

Site - Cairn Basin Shelter is sited below the timberline at the edge of a small clearing slightly east of the Timberline Trail. It is visible from the main trail and easily reached via a short spur trail. Overall, the site is in good condition. Dirt and duff have built up to a height of roughly 6” - 1’ on each elevation which will trap moisture against the masonry walls. Small plants are growing against the building. Large trees are close enough to fall on the building but they appear to be in good health. Otherwise there are no issues related to exposure, erosion, drainage, etc. The interior room is roughly square and measures approximately 10’ x 10’. The dirt floor has risen at least 6”. There is no evidence of floor below. *Recommended Treatment*: rake duff and vegetation away from walls to create a 2’ wide perimeter; rake out roughly 6” of dirt from inside the shelter.

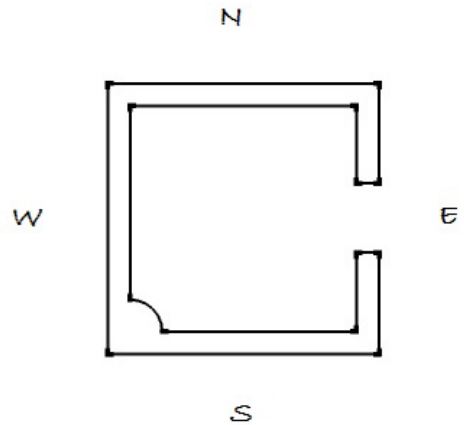

Plan



Site, north elevation

Walls - Cairn Basin Shelter has a 12' x 12' square footprint and masonry walls rising to a height that ranges from 9' at the front to 5'6" at the rear. The walls are in direct contact with the ground. A single entrance is located on center in the east elevation. The random rubble walls are 1' thick, smooth to the interior and rough to the exterior with no recognizable coursing. Masonry units appear to be a local igneous rock. On average, mortar joints are 1"-2" thick and applied with a rough or rustic technique. The strong, light grey mortar appears to have a high degree of Portland cement. Overall, the masonry is in good condition. Approximately 5% of exterior mortar has failed and exposed loose stones and small holes. The damage is exclusively cosmetic and has not lead to any structural damage. *Recommended Treatment:* walls can be repointed for cosmetic purposes, but this is not a significant work item. Loose or fallen chunks of mortar can be broken up with a hammer and dispersed around the site.



Typical wall construction and condition, north elevation



Typical interior construction and condition

Chimney & Fireplace - A stone chimney located at the rear of the shelter creates a bulge in the exterior masonry wall at the southwest corner. It is in good condition. The chimney is uncapped and the flue is clear. The fireplace appears to be intact but is roughly built in comparison to the fireplace at McNeil Point Shelter. *Recommended Treatment:* if historical photographs or illustrations can be used to verify the original form of this fireplace at Cairn Basin Shelter, it could be repaired to match the original.



Rear elevation and chimney



Fireplace

Roof Structure - This roof appears to be a replacement that alters the original peeled-pole design, although it is not clear when the roof was replaced. Forest Service photographs from the 1970's show the same roof in place. The roof is constructed from two peeled-poles and seven milled rafters that run north-south. The 12'3" rafters are supported by a single 14' 9" milled beam that runs east-west on center and is embedded in the masonry walls. The poles have a 5" diameter on average and the joists and beam have an 8' x 4' profile. Overall, the roof structure is in fair condition with one urgent failure that can be repaired in place. The beam may have failed under tension from snow loads overhead and a large knot that causes a weak point in the grain. Insect holes are visible in the pole rafters but they have not caused structural damage. The milled rafters are sound. *Recommended Treatment:* a 4' crack in the beam could be repaired by sistering a board on either side; In the long term, this beam may need to be replaced in full.



Rafter types



Cracked beam

Roof - The roof has a slope of 3/12 and is clad in 7' x 28" corrugated steel panels installed with a 2' x 5' reveal. Steel panels are rusty but do not need to be replaced yet. Water is infiltrating at the southeast corner from an open seam around the chimney. A 1' x 1' hole at the north side of the roof may have been caused by a fallen tree limb. It is ineffectively patched with plastic and rocks. *Recommended Treatment:* sealed seam around the chimney with caulk or tar (which has evidently been used before), and repair the hole in the roof by replacing the plastic and rocks with a new panel of corrugated steel.



Typical roof construction and condition



Failed seam at chimney

McNeil Point Shelter

Site - McNeil Point Shelter is sited above the timberline on a prominent bluff with sweeping views of Mount Hood, the Muddy Fork River, and several peaks in the Cascade Range. Exposure and erosion have caused a critical issue in front of the north elevation where light, sandy soil has been eroded by visitors, water runoff, and wind. Small plants are growing against the building and could be retained as a strategy to prevent further erosion. The grade has dropped as much as 3' below the bottom of the walls. *Recommended Treatment:* reinforce the ground in front of the shelter with riprap. An area roughly 5' x 20' across and sloped from 3' to 6" deep could be filled with rock. The rock can be quarried from scree fields uphill within ¼ mile of the site. The riprap will compress over time and do not need to be topped with soil as this will erode quickly. Riprap installation is a critical work item that will stabilize the building and prevent severe damage in the near future. It could be done by a trail crew and does not require preservation expertise.

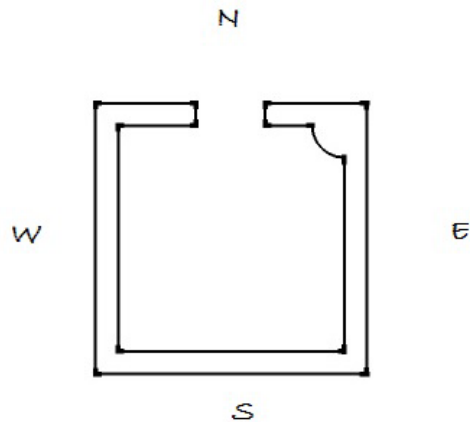

Plan



Awl inserted below wall



Awl depth



Site condition

Walls - McNeil Point Shelter has a 12' x 12' square footprint and masonry walls rising to a height that ranges from 11' at the front to 6'6" at the rear. The walls are in direct contact with the ground. The random rubble walls are 1' thick, smooth to the interior and rough to the exterior with no recognizable coursing. Masonry units appear to be a local igneous rock. On average, mortar joints are 1"-2" thick and applied with a rough or rustic technique. The strong, light grey mortar appears to have a high degree of Portland cement. Overall, the masonry is in good condition and does not need to be repointed but a large section of the north elevation above the door is in critical condition. A wall segment comprised of half of the north elevation, the northwest corner, and the west wall has travelled away from its original location due to erosion below the north elevation. The lintel is in critical condition. There is a continuous 4" vertical crack through stones and mortar joints at the southwest corner. It penetrates the wall and is visible from both the outside and the interior. It appears to be mostly cosmetic and does not need to be repaired. Since this building has no long vertical mortar joints, a patch or mortar fill would be noticeable. *Recommended Treatment:* After riprap is installed, repair the north wall by repointing cracks with mortar. Alternatively, the damaged area can be removed and rebuilt when the roof is replaced, in which case most stones can be reused. The repaired section of wall will be roughly 2'4" tall, 6' wide, and 1' thick. Mortar can be mixed to match the original, but the local soil has a fine texture that would be a poor aggregate. The lintel could be replaced with a slightly larger stone.



Condition in north elevation

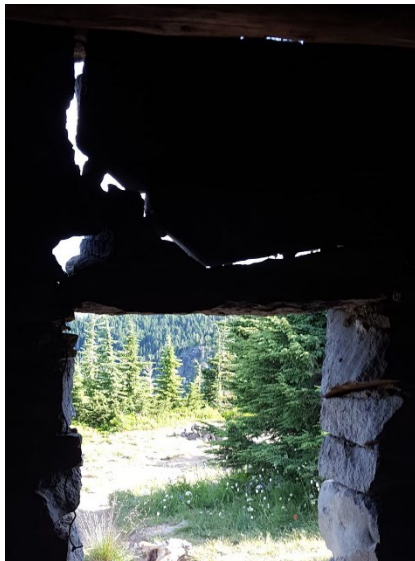

Condition at southwest corner



Chimney & Fireplace - A stone chimney located at the front of the shelter is flush with the exterior masonry wall at the northeast corner. It is in good condition. The chimney is uncapped and the flue is clear. The fireplace appears to be intact and its design is more formal than the fireplace at Cairn Basin Shelter.



West elevation and chimney



Fireplace

Roof Structure - The roof is constructed of 10 poles running east-west and is in poor condition. Several rafters have broken. These appear to be original logs. They have a steep taper, typically from 4" - 9" over a 12'6" length. They appear to have been collected onsite from slow-growth alpine trees with dense rings and steep tapers. Tool marks indicate that the poles were prepped with spuds and hatchets rather than draw-knives and bark was removed while they were green. The pole-ends rest on top of the masonry walls and are held in place with mortar. *Recommended Treatment:* replace rafters in full rather than repair in sections to ensure a strong roof. A crew may determine that some pieces can be reused but can expect to replace all the rafters. Some masonry repair will be needed when the rafters are replaced. Expect to repoint two sections approx. 12' x 1' x 1'.

Roof - The roof has a slope of 3/12 and is clad in 26" x 4'4" corrugated steel panels installed with a 3'10" x 4'2" reveal. The panels are in poor condition. *Recommended Treatment:* replaced all roof panels. A crew may determine that some pieces can be reused but may expect to replace 100% of the roof. New panels could be slightly larger, 28" x 4'6", to increase seams and extend drip lines. This is a very slight design change that will extend the roof's lifetime.



South elevation and roof construction. John Milliken.



Roof construction

Cooper Spur Shelter

Site - Cooper Spur Shelter is sited well above the timberline on the shoulder of Cooper Spur with sweeping views of the Columbia River Gorge and Mount Adams to the north, Mount Hood to the west, and the Deschutes River to the east. Exposure and erosion have caused an issue in front of the north elevation where sandy soil has worn away on the downhill side of the building. Stones have been piled against the south, east, and north elevations to anchor I-beams cabled to the roof and prevent erosion at the base of the walls. A thick rubber mat hung in the doorway may also help prevent the floor from eroding, because it blocks wind and weather. *Recommended Treatment:* slight erosion could be addressed by installing a rough threshold of dry-laid stones in the doorway. This would reduce erosion that will otherwise undermine the walls. This work could be done by a trail crew.

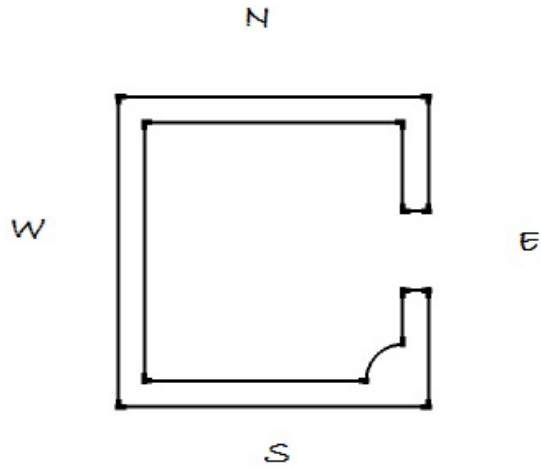

Plan



Site condition

Walls

Cooper Spur Shelter has a 12' x 12' square footprint and rough coursed masonry walls rising to a height that ranges from 10'8" at the front to 4' at the rear. The random rubble walls are roughly 1' thick, just like other stone shelters along the Timberline Trail. The grey mortar appears to have a high degree of Portland cement and a dark grey aggregate with a coarse sandy grain. Overall, the masonry is in fair condition and does not need to be repointed but there are two concerns that could be monitored in the future.

Some stones have fallen or been removed from the exterior side of the rear wall. The missing pieces are evident from the exterior, and even more so on the interior where shafts of light strike through small holes in the otherwise solid masonry wall. The missing stones do not presently create a structural concern but must at be monitored to ensure that they do not continue to expand. More stones are loose, either because mortar has worn away or because it was minimally applied. *Recommended Treatment:* As time allows, these missing patches could be refilled with stones that are spread across the site near the shelter. The three largest areas missing stones on the exterior of the rear wall measure roughly 1' x 6", 1' square, 1' square, but photography will be the most effective way to monitor this condition moving forward.



Rear wall condition and missing stones, 2017



Rear wall condition, 1978. Courtesy of USFS

At the southeast corner, two large continuous vertical cracks are evident. One is located on the south wall, and one is located on the east wall. The cracks follow mortar joints and have not split through stones. They penetrate the wall and let light and weather into the chimney flue. Hikers' photos from the last decade indicate that these cracks are not new, and they are slightly visible in USFS photographs from August, 1978. If the cracks have stabilized they can be considered a cosmetic issue, but not a structural issue that needs to be repaired. Since this building has no long vertical mortar joints, a patch or mortar fill would be noticeable. *Recommended Treatment:* cracks do not need be patched with mortar unless they continue to expand and pose a structural concern.



South wall condition and vertical crack, 2017



South wall condition, 1978. Courtesy of USFS

Chimney & Fireplace - A stone chimney located at the front of the shelter is flush with the exterior masonry wall at the northeast corner. It is in fair condition. The chimney is uncapped and the flue is clear. Unlike the other shelters, Cooper Spur Shelter's chimney is lined with a piece of corrugated steel rolled into cylinder. It forms a crude stovepipe that is 3' tall and has a 6" diameter. The fireplace appears to be intact. Its craftsmanship is more rough that at McNeil Point Shelter, and resembles the stone work at Cairn Basin Shelter. Large masonry units at the top of the chimney are loose. Two vertical cracks in the chimney walls presumably affect how it functions when there is a fire in the fireplace, but the shelter and its fireplace are not typically used so this is a minor concern. *Recommended Treatment:* repoint the top of the chimney to prevent damage to the shelter and to protect visitors who may otherwise be injured by falling stones.



Fireplace



Vertical crack



Corrugated steel stovepipe and loose stones

Doorway - The shelter doorway faces east, away from Mount Hood. The doorway has been altered with a metal lintel. Historical photos confirm that the original lintel was a continuous piece of stone which is still in place. The doorway was filled in and lowered, and the new lintel installed about 1' below the original. This alteration appears in a photograph from August 1978 and it may have been installed along with the new roof. A thick rubber mat hangs in the doorway, suspended on wire, carabineers, rope. The mat is clearly not original and was probably not installed by Forest Service staff so heritage resource managers will decide whether it serves a useful purpose and should be retained. Even though they are not original, the lintel and mat are reasonable, reversible alterations that can be retained. They do not appear to be damaging the building and may genuinely help hikers utilize the building as an emergency shelter.



Original doorway, date unknown. Courtesy of USFS.



Altered doorway



Metal lintel

Roof - Cooper Spur Shelter was probably built with a roof of corrugated steel panels, much like the construction of McNeil Point Shelter and Cairn Basin Shelter. Today, it has a metal standing seam roof anchored by cables, iron I-beams, and piled rock on top of the roof and against the north and south elevations. The roof was described as “new” in a cultural resource survey form completed by Jon Horn in August of 1978. This design indicates that the shelter roof must withstand severe storms and/or strong winds. It is an appropriate intervention that has prolonged the life of this shelter. However, it does represent a loss of integrity that has altered the original design, craftsmanship, and materials of Cooper Spur Shelter.

Five iron rafters run from east-to-west and are in good condition. The standing seam roof is comprised of seven panels, all in good condition except for graffiti scrawled on the undersides which are accessible from inside the shelter. All wires that anchor the roof are in good condition; three out of the four wires are under slight tension. Photos from 1978 show that the roof was once covered in a layer of stones; roughly half of these stones are still in place. Orange spray foam fills small gaps between the metal roof and the masonry walls. The foam probably makes the shelter more comfortable when it is used in emergencies. It can be retained if heritage resource managers believe that it serves a useful purpose. However, it is another intervention that has altered the integrity of this historic resource.



Roof construction



Graffiti



Spray foam

Summary of Work Items

SYSTEM	CONDITION	URGENCY	TASKS
Elk Meadows Shelter			
sills	Poor	critical	Replace rear sill: 14'6" long 1' diameter log. Replace side sills: two 11' long 1' diameter logs. Make the structure level and plumb.
posts	Poor	critical	Retain, repair, or replace posts as follows: Northwest corner (Post #1) replace in full with 8' long 10" log or replace the bottom end by scarfing a 4' section. West wall (Post #2) replace 10'x10" log or repair 3'. West wall (Post #3) replace 8'x10" log or repair 2'. Southwest corner (Post #4) retain original 5'x7" log. Rear wall (Post #5) retain original 5'x7" log, but consider removing 1" from the bottom and raising or shimming the sill notch below. Rear wall (Post #6) replace 5'x7" log or repair 2'. Southeast corner (Post #7) replace 5'x7" log. East wall (Post #8) replace 8'x10" log or replace 3'. East wall (Post #9) replace 10'x10" log or replace 6'. Northeast corner (Post #10) replace 8'x10" log.
beams	Poor	critical	Repair rear beam: replace in full with a 14' long 8-10" diameter log, or replace 7' long section with 8-9½" diameter. Replace ridge: two 14' long 10" diameter logs.
site	Fair	urgent	Remove hazard trees, if feasible. Remove duff and small plants within 2' of walls to keep sill logs relatively clean and dry.
roof structure	Fair	urgent	Replace broken nailer: 6' long 2x4. Repair rafter tail: scarf 3' long 4" diameter pole. Consider reconstructing east roof to restore original design with poles instead of 2x4s, and 30" shakes coursed with a 20" reveal.
wall structure	Fair	urgent	Replace braces as needed: ten 6'x5" poles. Replace horizontal nailers: seven 5' long 3" diameter poles. Replace roof edge nailers: five 5' long 2" diameter poles
shakes and shingles	Fair	urgent	Repair walls: 80 linear feet of 30" shingles, or 160' linear feet of 30" shakes. For historical accuracy and a complete restoration, all shingles could be removed and replaced with shakes. Repair roof: 50 linear feet of 30" shakes.

Gnarl Ridge Shelter			
walls	poor	minor	Monitor and document deterioration.
roof	poor	urgent	Repair beam: sister two 6' x 2" x 6" boards or replace with 15' x 4" x 8" board. Repair mortar around beam: two 1'x1' sections. Repair roof: two 28" x 7' corrugated steel panels.
site	good	minor	Clear 6"-1' of duff and plants within 2, remove roughly 6" layer from dirt floor
McNeil Point Shelter			
site	poor	critical	Install riprap in a section 5' x 20' x 3' - 6" to prevent erosion and stabilize front wall
walls	poor	critical	Repair north wall: repoint or rebuild 2'4" x 6' x 1' section. Replace lintel: one 4"-5" tall, 3'5" - 3'8" wide, and 1'8" stone.
roof	poor	urgent	Replace rafters: 14' logs, trim to 12'6". Diameters: 7 1/2" - 6", 7"- 4 3/4", 7 1/4" - 6 3/4", 4" - 8 1/2", 8 1/2" - 4 1/4", 4" - 7 3/4", 9" - 6 1/2", 4" - 8 1/2", 8 1/2" - 5", 3 5/8" - 6 1/4". Repoint masonry around rafter tails: two 12'x1'x1' sections. Replace roof: twelve 28" x 4'6" corrugated steel panels.
Cooper Spur Shelter			
walls	fair	urgent	Monitor loose stone at the rear wall and two cracks in the chimney. Repoint top of chimney and patches of rear wall using mortar, aggregate on site, and stone on site.
site	good	urgent	Reinforce ground at front elevation with dry-laid stone to prevent erosion
chimney	poor	minor	If fireplace should be operational, repoint cracks with mortar and aggregate on site
roof	good	minor	Remove or conceal graffiti

Proposed Access

Elk Meadows Shelter and Gnarl Ridge Shelter

Both Elk Meadows Shelter and Gnarl Ridge Shelter are located in the Hood River Ranger District of the Mount Hood National Forest and are accessed from the Elk Meadows - Sahalie Falls Trailhead. The trailhead can be reached by driving 18 miles from the district headquarters in Parkdale, OR via OR-35-S and Forest Road #3545. Roads are well maintained and signage is clear all along the route. The trailhead provides parking for at least 30 vehicles and is convenient for a truck and trailer.

From the Elk Meadows - Sahalie Falls Trailhead, both shelters are reached via the Elk Meadows Trail (#645). Finding this trail from the parking lot is somewhat confusing, but clear signs are placed at every turn. Hikers should not turn down unmarked side trails. Follow Sahalie Falls Trail (#667C) for 0.4 mile and then Umbrella Falls Trail (#667) for 0.1 mile to reach Clark Creek and the wilderness boundary. A large foot log bridge and a ford for stock animals make it easy to cross the creek. Proceed 0.6 miles along Elk Meadows Trail (#645) to Newton Creek. Newton Creek requires an unassisted creek crossing that may be hazardous at high water. There is no bridge and no obvious ford for stock. After Newton Creek, the trail continues to the left and begins climbing uphill in a series of switchbacks. The trail rises from 4,600’ at Newton Creek to 5,260’ at the final switchback. At the top of this rise, a four-way intersection provides divergent routes to Elk Meadows Shelter and Gnarl Ridge Shelter.

Route to Elk Meadows Trailhead. Google Maps.

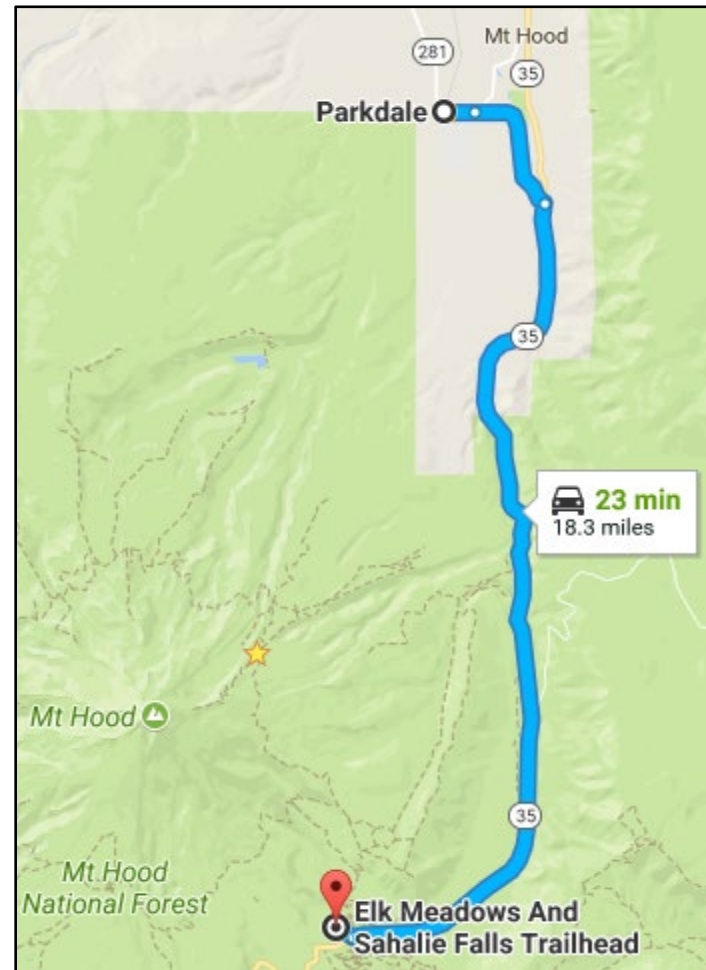

For Elk Meadows Shelter, stay on Elk Meadows Trail for 0.6 miles. Elk Meadows Trail travels around the east side of the meadows while a secondary perimeter trail travels around the west side. Either trail will lead to the shelter which is located at the meadow's southeast edge and is visible at the tree line where its facade faces towards Mount Hood. Elk Meadows Shelter is located at approximately 45.344597, -121.615858.

For Gnarl Ridge Shelter, head northwest on Gnarl Ridge Trail (#652) for 1 mile to reach the Timberline Trail (#600). This short section of trail rises from 5,260' at the intersection with the Elk Meadows Trail to 5700' at the Timberline Trail. Turn right and proceed on the Timberline Trail for approximately 1 mile. The ruins of Gnarl Ridge shelter, located at approximately 45.361181, -121.649100, is sited on the south (left) side of the trail, below the peak of Lamberson Butte and the shoulder of Gnarl Ridge.



Trail to Elk Meadows Shelter. www.naturalatlas.com.

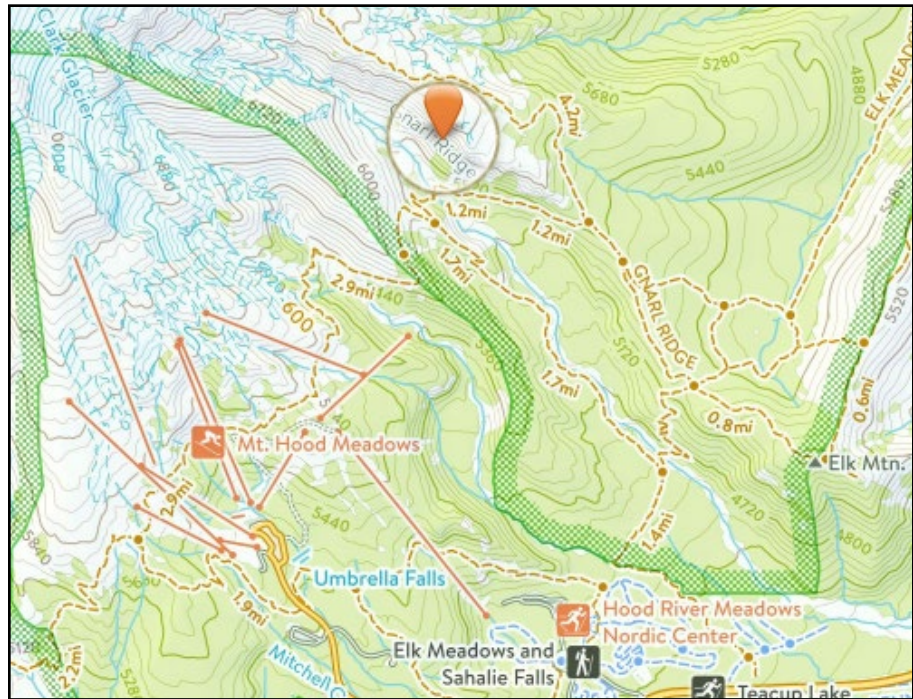

Trail to Gnarl Ridge Shelter. www.naturalatlas.com.

The shelter is located on a flat site where all necessary crew members could work effectively at one time. Many camping sites can be found in the trees surrounding the meadow. Cool Spring Creek provides a reliable water source throughout the summer. The meadows are delicate and boggy, and should not be used for camping or working. However, the tree line around the meadows provides many small clearings where a crew can camp and work. Hazard trees should be considered and avoided when choosing specific camping sites for the crew members.

The recommended method for future work at Elk Meadows would be a) a pack train or b) helicopter flights. Stock can access Elk Meadows via the Elk Meadows trail. The trailhead provides sufficient room for trailers, and the route provides many creeks where stock can be watered. It does not provide any places to graze. The switchbacks above Newton Creek and the ford across Newton Creek may be difficult for a heavy-laden pack string. Staging areas were not identified during this assessment but several parking areas along OR-35 could provide enough room. The Elk Meadows - Sahalie Falls Trailhead is not a feasible staging area. Elk Meadows may be an appropriate place to drop-off or retrieve supplies near the shelter, but the meadows are saturated with water even in late August.



Newton Creek



Elk Meadows

Cairn Basin Shelter and McNeil Point Shelter

Both Cairn Basin Shelter and McNeil Point Shelter are located in the Zigzag Ranger District of the Mount Hood National Forest and are accessed from the Top Spur Trailhead (45.4074, -121.7856). Top Spur Trailhead can be reached by driving 12 miles from the district headquarters in Zigzag, OR via Lolo Pass Road, Forest Road #1825, Forest Road #1828, and Forest Road #118. Roads are well maintained and signage is clear all the way to Top Spur Trailhead. The trailhead offers room for approximately twenty cars but it may be too narrow to turn a truck and trailer around.



Route to Top Spur Trailhead from Zigzag. Courtesy of Google Maps.

From Top Spur Trailhead, travel 4.0 miles on the Top Spur Trail and the Timberline Trail to reach a junction with the McNeil Point Trail at approximately 45.4027, -121.7283. The elevation gain from Top Spur Trailhead (3900') to McNeil Point junction (5000') is 2100'. Divergent trails lead to Cairn Basin and McNeil Point.

To reach Cairn Basin, continue 0.7 miles north along the Timberline Trail. The shelter is located at approximately 45.4043, -121.7241 and 5700'.

For McNeil Point, proceed along the McNeil Point Trail for 1.0 mile. The shelter is located at approximately 45.3954, -121.7318 and 5900'.

All junctions are clearly signed. Top Spur Trail and the Timberline Trail have frequent water sources and small campsites between the all the way to McNeil Junction. The trail requires several creek crossings. Established camping sites at the trail junction, Cairn Basin, and McNeil Point would serve a small crew. A glacial stream that crosses the Timberline Trail near the junction with the McNeil Point Trail provides a reliable source of water. The shelters are each located on a flat site where all necessary crew members could work effectively at one time.



Trails to Cairn Basin Shelter [above] and McNeil Point Shelter [below]. www.naturalatlas.com.

The recommended method for future work at Cairn Basin and McNeil Point would be a) helicopter flights from an unidentified staging area or b) a pack train.

Staging areas were not identified during this assessment but several clearings and parking areas along East Lolo Pass Road could provide enough room. Top Spur Trailhead is not a feasible staging area. To minimize flight distances, the best site might be located south of Rebel Rock Lookout along North Fork Road. Helicopters may be able to drop and retrieve supplies in Cairn Basin, near the shelter. They are certainly able to drop and retrieve supplies from McNeil Point. A helicopter could be landed at the Point in the case of an emergency evacuation.

The Top Spur Trailhead provides room for a horse trailer to park but may be too small to turn around without difficulty, especially on a busy summer weekend. Personal stock are not allowed on the relevant section of the Timberline Trail but it may be worthwhile for the Forest Service to consider allowing stock for an administrative use. The trail to Cairn Basin is appropriate for stock. However, the McNeil Point Trail may be too steep and narrow to reasonably travel with a heavy-laden pack train. In some places the overhead clearance is insufficient for stock. McNeil Point Trail is likely to be buried under snow in late June and early July. Several large meadows near both shelters provide ample space to string up a high-line, unpack the train, and/or turn the train around, although these are marked for habitat restoration.

Cooper Spur Shelter

Cooper Spur Shelter is located in the Hood River Ranger District of the Mount Hood National Forest and is accessed from either the Cloud Cap or Tilly Jane trailheads. Tilly Jane is preferred. Reach the trailhead by driving 21 miles on OR-35-S and Cooper Spur Road. At the Cooper Spur Mountain Resort, turn left onto Cloud Cap Road (Forest Road #3512). Follow Cloud Cap Road for 10 miles to reach Tilly Jane campground and the preferred trailhead. The route is well signed but several intersections are confusing. On Cloud Camp Road, continue past the Tilly Jane Sno Park trailhead at mile 1.5 and consistently follow signs for Tilly Jane Campground, Cloud Cap, and Cooper Spur. At a mile 9.6 a T-shaped junction provides access to either Cloud Cap Inn or Tilly Jane Campground. Turn left and proceed to Tilly Jane Campground at mile 10.0. Cloud Cap Road is a narrow gravel road with few turnouts, steep shoulders, and deep ditches. It is not recommended for a truck and trailer, but would be feasible for a truck with 4-wheel-drive. The trailhead offers room for approximately twenty cars.

Route to Tilly Jane Campground. Google Maps.

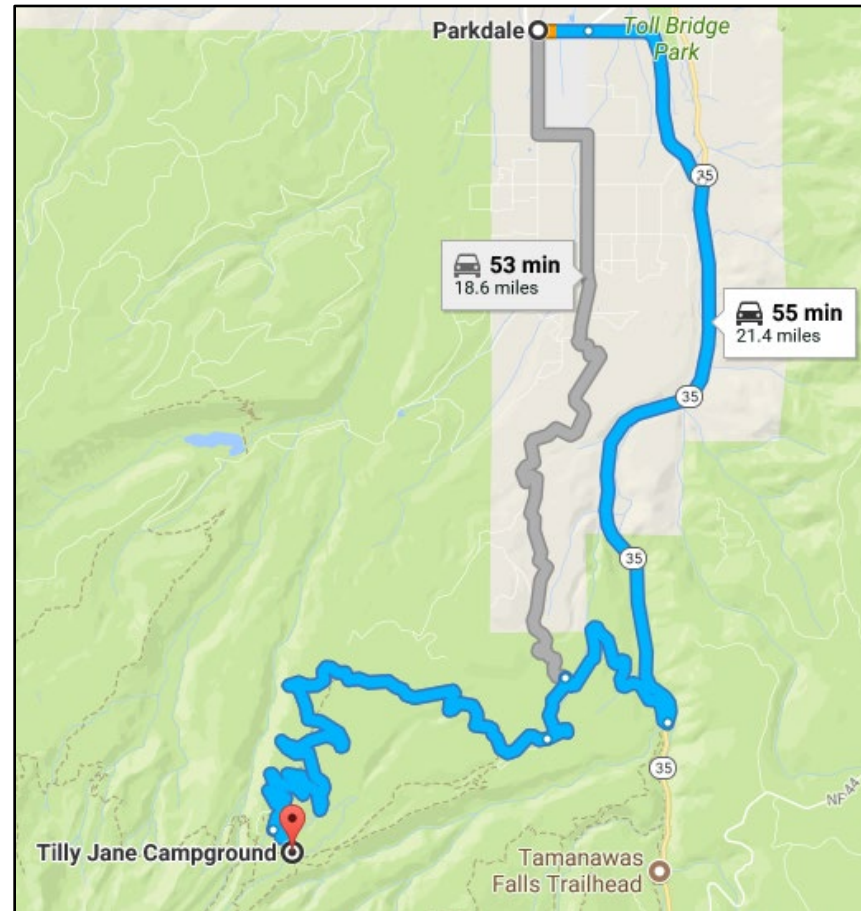

From the day-use parking area at Tilly Jane Campground the trailhead can be found by heading towards the old Tilly Jane Guard Station, which is visible from the parking area. Veer right of the ranger station to pick up the Tilly Jane Trail (#600A), which is signed. The Tilly Jane Trail climbs steeply for 1.0 mile, rising from an elevation of 5,740' to 6,650' to end at a four-way junction with the Timberline Trail (#600). Cross the Timberline Trail at this intersection and proceed straight on the Cooper Spur Trail (#600B) for 0.1 mile to reach Cooper Spur Shelter.

The recommended method for future work at Cooper Spur Point would be to hand carry supplies from the Tilly Jane Campground. The shelter does not require substantial repairs, the road to Tilly Jane Campground does not easily accommodate a trailer for stock, and the trail to Cooper Spur Shelter is quite short. It will not be necessary to use a helicopter or stock train, as long as the shelter's condition is consistently maintained. If necessary, a helicopter could deliver supplies to a worksite at or near the shelter, because the area is exposed.



Trails to Cooper Spur Shelter. www.naturalatlas.com.



Tilly Jane #600A

Waldo Mountain Lookout

Waldo Lake Wilderness, Willamette National Forest

Charlotte Helmer, HistoriCorps Principal Investigator

December 2017



Summary

Waldo Mountain Lookout is located in the Middle Fork Ranger District of the Willamette National Forest and is accessed from the Salmon Lakes - Waldo Mountain Trailhead, 25 miles from the district headquarters in Westfir, Oregon. Waldo Mountain Trail (#3592) which rises from an elevation of 4360' at the trailhead to 6360' at the lookout over 3 miles of trail. The lookout's coordinates are approximately 43.7653, -122.0990.

The lookout is a single story building on top of a rubble and concrete pier foundation with a footprint of 15' x 15'. It is of stud framed construction, clad in plywood, and has a flat roof clad in rolled asphalt. The lookout's most distinctive features are its flat roof with wide eaves, continuous catwalk, and windows across all four elevations. A single door is offset in the north elevation. The current lookout was constructed in 1957 and replaced a D-6 cupola lookout, built in 1929 or 1930. It is demonstrative of the R-6 style which was developed in 1953 and represents the final phase of fire lookout construction throughout Region 6.

As of its assessment on July 11, 2017 Waldo Mountain Lookout is in good-to-fair condition. The roof, catwalk, and south elevation have sustained damage that will escalate quickly if they are not repaired. Otherwise, the lookout is well maintained and kept in service. Waldo Mountain Lookout retains a high degree of integrity in all seven of the characteristics that are typically considered: setting, location, craftsmanship, design, materials, feeling, and association. Preservation projects could be completed by a small group of experienced preservation carpenters or volunteers supervised by experienced project managers.



Waldo Lake see from Waldo Mountain Lookout

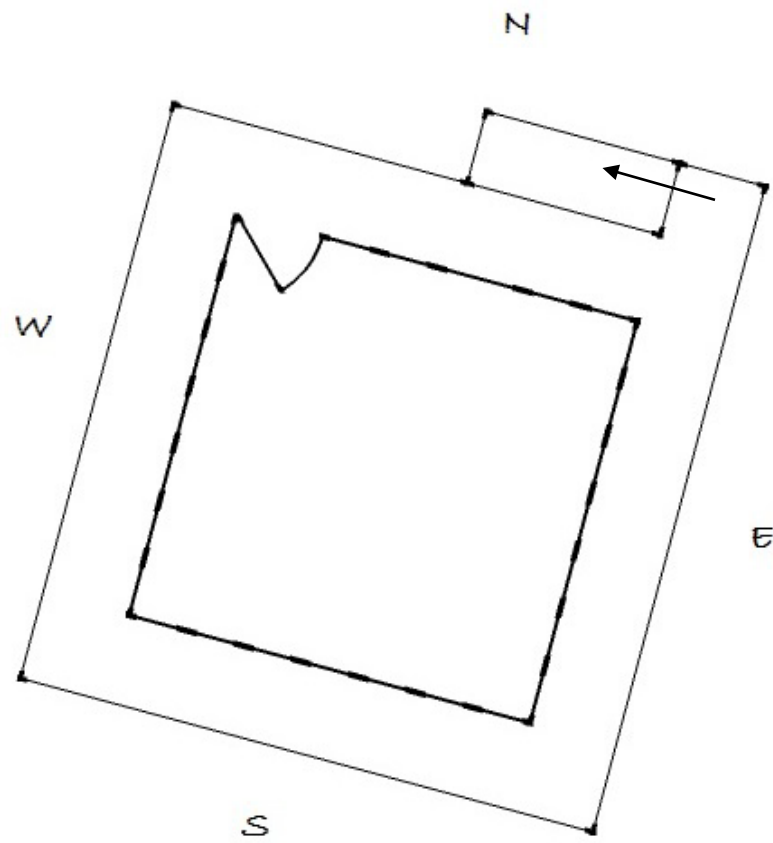

WALDO MOUNTAIN LOOKOUT

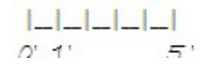

Site

Waldo Mountain Lookout is sited on a solid base of rock with steep slopes descending to the north and south and gradual slopes to the east and west. Overall, the site is in good condition; common concerns such as overhanging branches, water runoff, erosion, and duff are not an issue. The site provides excellent drainage and ventilation for the lookout. Historic viewsheds are intact. Exposure is significant but not extreme and it primarily affects materials on the southeast side of the building. Trash from the lookout is strewn under the catwalks and around the site.



West and south elevations and south



Steep, rock grade

Exterior

Foundation - The foundation is in excellent condition. It is constructed of board-formed concrete piers that average 1' x 1' x 2'. Several piers are made from large stones capped with mortar and others are shimmed with plastic felling wedges to support floor joists. No crumbling, cracks, biogrowth, or other concerns are evident in the foundation.

Floor structure - The floor structure is in good condition. The foundation piers support three floor joists that run north-south. Each joist is comprised of three boards sistered together. Another set of sistered joists run east-west on top of the first level. These upper joists are flashed to create a drip line at the seam between the lookout's catwalk and walls. A third set of smaller floor joists run north-south and supports the subfloor above. On the west elevation, two lumber racks hang from floor joists under the catwalk deck. These racks place an unnecessary load on the joists. On the east elevation, the crown of an east-west running joist has cracked and the catwalk deck above has failed. *Recommended Treatment:* repair the cracked joist by sistering two 8' long 2x10 boards. This joist repair would ideally be made before the catwalk deck is repaired. Remove the lumber storage racks.



Lumber rack suspended from west side catwalk



Cracked joist below east side catwalk

Catwalk fascia - The fascia are in fair condition. The cracked joist on the north elevation has resulted in a broken fascia board below the catwalk. The break is located roughly 6 feet from the northeast corner of the deck. The fascia boards are nominally 2x10s. On the south and north elevations, one end of a fascia board has been fastened aggressively and is riddled with holes. *Recommended Treatment:* replace the broken fascia board in full. Several posts that the fascia are fastened too may require reinforcement, which could be done at the carpenter's discretion using spare lumber sistered below the deck and kept out of sight.



Damaged section of the catwalk on the east elevation

Catwalk deck - The catwalk surrounds the lookout cab on all four elevations and is in fair condition. *Recommended Treatment:* replace a single 3' section of 1x3 decking and reinforce the rest of the existing boards by driving in nails that have backed out.

Catwalk railings - The railings are in fair-to-poor condition. They are typically constructed with five 4x4 posts on each side of the lookout, 2x4 diagonal braces at each corner, and 2x4 horizontal rails fastened with 3/16" thru bolts. Each of the four sides is built differently: posts are installed either in front of or behind the fascia, rails are misaligned or missing, posts extend to the ground or are just 4' long, and two railings accommodate a short flight of steps at the northeast corner. Before the railings are repaired it would be best to consult historic photos of the lookout and typical plans of the R6 lookout type in order to the original design of these railings. The north side railing is in poor condition. Two rails are missing and an original post was replaced with an 8' long pressure treated 4x4 that reaches all the way to the ground. The northeast corner is crudely reinforced with a post that reaches to the ground. A hiker's photo from 2002 shows that the northeast corner of the deck was cantilevered (not supported by a post) and the missing rails were intact. The east railing is broken in several places. The south and west railings are sound. *Recommended Treatment:* replace missing rails, posts, and one diagonal brace. Once the damaged joist and fascia are repaired, it might be possible to remove the northeast post.

Stairs - The stairs are in fair condition. The bottom step appears to be a repurposed door sill and it could be trimmed to resemble the other treads. *Recommended Treatment:* consider reinforcing the stairs with screws installed from the underside.



North elevation, railing design



West Elevation, railing design



South and east elevations, railing design

Wall structure - The wall structure was inaccessible but is likely framed with 2x4 studs spaced 2' apart. A problem is occurring at the south wall which is evidently separating from the east and west walls. A 2" wide gap has opened up all along the southeast corner and a smaller gap is visible on the southwest corner. These have been filled with caulk but continued to expand, especially the northeast corner. It is likely that a missing section of roof and the open access hatch in the roof's eave at the southeast corner may be contributing to this problem by exposing the south wall to rain. The east and west elevations are bolted to the foundation. *Recommended Treatment:* monitored the issue and investigate by removing siding from the interior or exterior, and opening the ceiling in order to identify the failure mechanism in more detail. At minimum, the corner gaps could be filled with caulk, as has been done in the past.

Exterior siding - Each elevation is clad in plywood sheets inscribed with a pattern that mimics 4" wide vertical boards. The siding is in fair condition. As mentioned, the south corners are separated and have been filled with caulk.

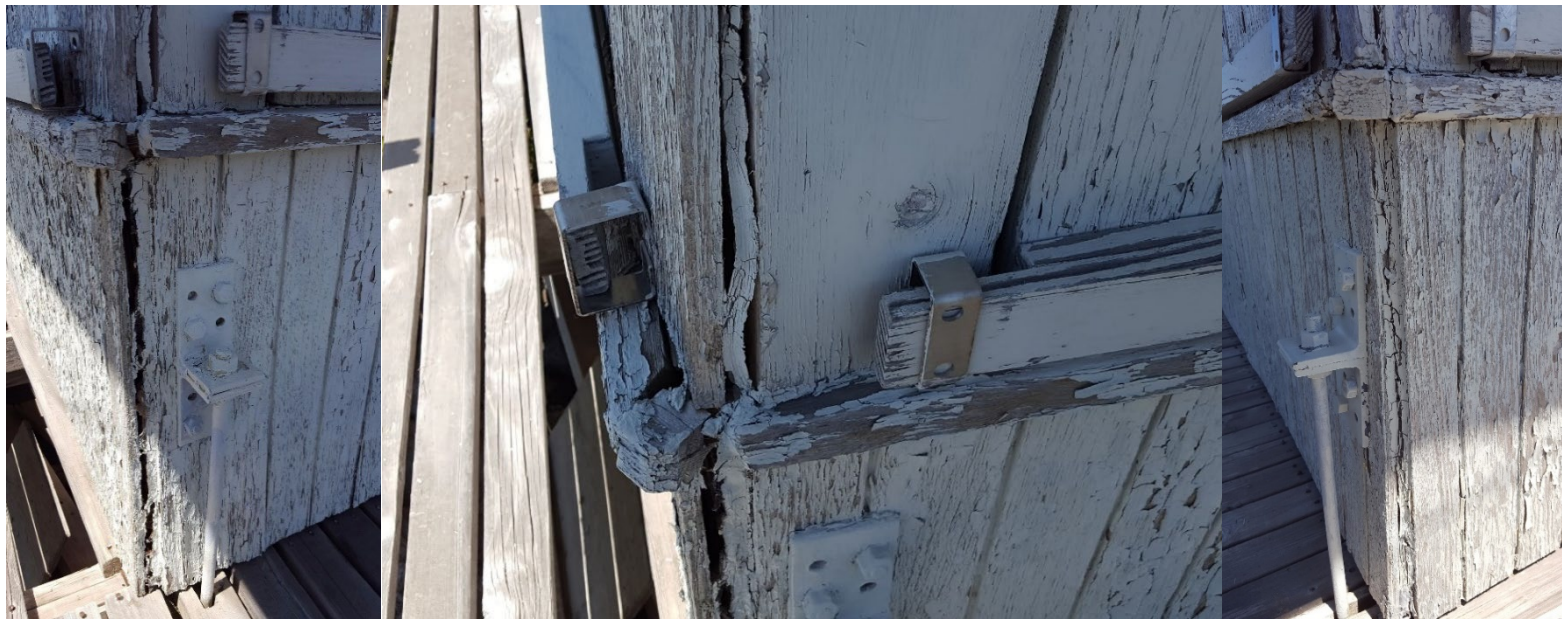

Condition at southeast corner

Caulk used to patch the southwest corner

Condition at southwest corner

Exterior trim - Each elevation is trimmed with corner boards alongside the windows, baseboards, horizontal trim below the window sills, window sills, and headers above the windows. Overall, the trim is in fair condition, but the corners are poorly fitted throughout. It is likely that they were poorly installed to begin with and were roughly filled with caulk and small pieces of lumber. *Recommended Treatment:* in the short term, the corners could be scraped free of old paint and caulk and then refilled with caulk. Small pieces of lumber could be replaced with slightly larger pieces, individually fitted. For a more substantial repair, pieces of the trim could be moved closer together to close gaps at the corners and essentially displace the gaps to the center of each elevation where they could be repaired with short lengths of trim. The trim could be addressed at a carpenter's discretion, and as time allows. Substantial repairs would ideally be made after structural concerns at the south wall have been addressed.

Exterior finishes - The lookout was previously treated with a light grey latex-based paint. Weathering, UV damage, and exposure have stripped almost all paint from the exterior, especially below the windows. *Recommended Treatment:* test for lead content, scrape surfaces, and treated with two coats each of primer and paint.



Typical construction and condition of trim below windows, above windows

Shutters - The shutter system is in good condition. Each window has an individual shutter constructed from a single layer of plywood with a slight curve cut in the bottom that serves as a handle when they are installed or removed. The shutters are designed to lift in and out of the window frames and are locked in place with two horizontal rails on each elevation. These 2x4 rails slide into hardware fastened into each corner board and are notched to fit around eye bolts installed through the central window sash on each elevation. Thru bolts fix the 2x4 to the eyebolts to prevent visitors from easily removing the rails. The punctured window sash and window sills below them have water damaged that is evidently caused by the shutter system. A few thru bolts are missing. *Recommended Treatment:* alter the current shutter system so that thru bolts no longer puncture the sash. If need be, the eyebolts could be anchored into mullions instead. In this case, each elevation would require one longer and one shorter 2x4 rail.

Door - The lookout's single door is on the north elevation. It was mostly inaccessible during this assessment but appears to have a hollow core filled with insulation and is in fair condition. The door and its shutter are locked with a Yale lock and a Master lock.



Typical shutter construction and condition



Condition caused by eyebolt installed through sash



Door construction and condition

Windows - Each elevation has seven four-light windows. Most are 4'6" tall and 2' wide, except for the central windows which are slightly wider at 2'4". Three casement windows located on the east, south, and west elevations are designed to open out and attract an east-west moving draft. The sash are mounted on a sliding hinge and open with a vertical pivot. Two open on their right sides, one opens on its left side. All other windows are fixed. All windows are painted on the exterior side and varnished on the interior. Overall, the window system is in good condition. All panes and hardware are intact. The only urgent concern is caused by holes and eyebolts that puncture four sash. The glazing putty is good condition, but small sections could be repaired in place. Window screens are provided for the operable windows and are all in good condition. *Recommended Treatment:* patch holes and rotted wood at the bottom of the sash with wood epoxy. If the damage gets worse these sashes will need to be removed so that the bottom rail can be replaced. Touch-up putty and paint. Headers above the operable windows could be slightly planed where the sash are scraping against them. Screen clips could be fastened to the interior mullions to make it easier to install the screens.



Typical window construction and condition



Sliding hinge

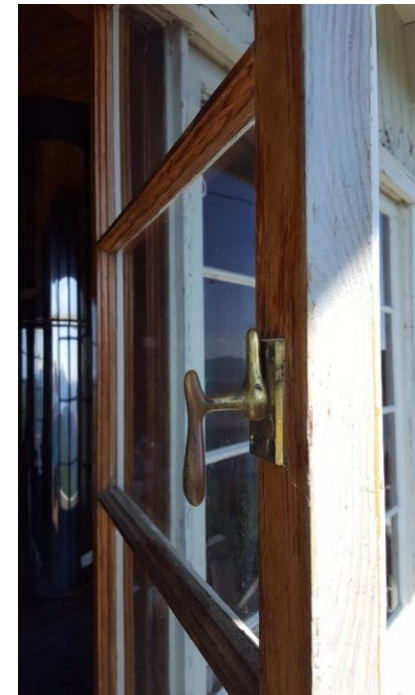

Brass catch

Roof structure - The roof structure was mostly inaccessible during this assessment, but appears to be in excellent condition. A 2' x 2' section of the roof above the south catwalk is open to the sky, which allows easy roof access but also exposes the windows, siding, and deck to weather. It is probably impacting the condition of multiple systems; the missing deck board, separation of the south wall, damaged window putty, and scraped sash all occur immediately below this opening. *Recommended Treatment:* cover the opening with a simple plywood hatch.

Roof - A section of rolled roofing on the south side is missing and has exposed the wood sheathing below. The patch measures approximately 8' x 10' and is a critical concern that has the potential to accelerate damage throughout the structure if it remains unrepaired through winter. Roofing nails are already on site inside the lookout. *Recommended Treatment:* replace roofing.

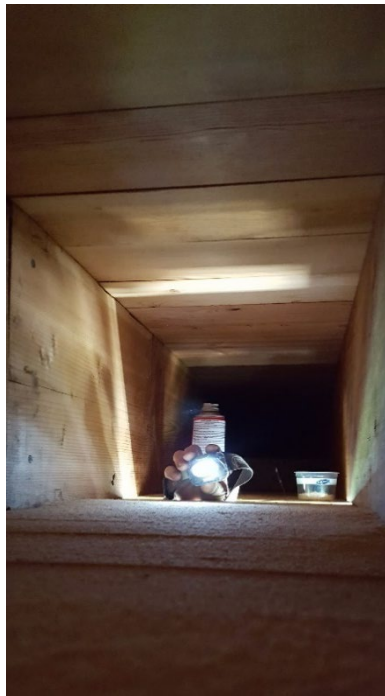

Ceiling cavity



Roof access



Roof condition

Interior & Operations

Waldo Mountain Lookout's interior is in good condition. The floor, walls, ceiling, and finishes are all maintained. Appliances and furniture are functional. What follows are a few recommendations to make the building more livable for occupants and more effective as an active lookout during fire season:

Floor - A linoleum floor and rubberized baseboard were recently installed and are in excellent condition. If linoleum was not originally used on the lookout's interior, it is still an appropriate alteration for an operable lookout.

Ceiling - Carpenter ants are active near the stovepipe at the northeast corner and at the south side of the building. Chewing sounds, staining, and holes indicate an active infestation. Chemicals have been used in the rafters (and remain as trash). Approximately 10' of 0.3.2 x 5.6.0 x 0.0.2 beadboard is need to replace missing boards. The roof structure is largely inaccessible because the roof is flat. Missing sections of the ceiling expose some parts of the structure, which all appear to be in good condition. However, it is possible that carpenter ants have damaged the rafters and there may also be damage to the south side of the building where a large section of roofing is missing. Investigation is needed and would made when the ceiling is removed. *Recommended Treatment:* open up the ceiling mitigate the ant infestation, and investigate possible damage to the roof structure. Reinstall the extant ceiling and replace missing boards, anticipating some breakage in the process.



Floor condition



Ceiling condition

Interior trim - The sills and aprons are in fair condition. Horizontal aprons below the window sills have a remarkable ovoid profile. Window sills have an odd construction: pieces of interior trim are beveled on the underside and fit into an opening that is counter-beveled such that the trim ends up flat on top. Eye-bolts installed into the bottom rail of several windows have damaged the sills in addition to the sash. These sills do not need to be replaced but could be varnished. Non-original trim in the northwest and southwest corners could be removed. These have been used to conceal a gap related to expansion at the south side of the building.

Interior finishes - The ceiling and walls above the windows are varnished, but walls below the windows have no finish to protect them. More investigation is needed in order to determine the materials and finishes were originally, but varnish may be appropriate for all untreated wood inside the lookout. *Recommended Treatment:* apply varnish to the walls and trim.



Window sill condition



Trim and wall condition at the southeast corner

Appliances - All appliances appear to be operable but it would be best to interview a USFS staff member who has been stationed in the lookout to find out if improvements would help them be effective in their work. The stovepipe is slightly misaligned. *Recommended Treatment:* repositioned the stove pipe and inspect to make sure that the flashing is effective.

Onsite Tools and Materials - Approximately 3 feet of metal flashing and several extra floor joist boards are stashed below the lookout. Additional linoleum squares are stored on site and can be used to maintain the floor. These could be used in small repairs or to augment supplies for a restoration project but are not a significant source of materials.



Panorama photo of the lookout interior (distorted)

Security - The building is fairly well secured against animals or trespassers. Shutters on the north end of the east elevation are somewhat easy to remove. With a small Phillips-head screwdriver the horizontal 2x4 rail and a shutter can be quickly removed to uncover a window that is both operable and unlocked. It appears that people have used this window as an entrance and egress for a long time. The window sill is scuffed and the catwalk deck immediately below the window is broken, two signs which indicates that people have climbed in and out. Fortunately, the exterior and interior show no signs of vandalism. If visitors are taking advantage of the open window they have been inclined to treat the building with care. The window could be secured, but is not an urgent priority.

Safety - The lookout cab is safe for visitors and Forest Service staff. The catwalk deck and railing may pose a hazard. *Recommended Treatment:* repair the catwalk deck and railing.



Unsecured window and broken catwalk on the east elevation present concerns about safety and security. Courtesy of John Milliken.

Summary of Work Items

SYSTEM	CONDITION	URGENCY	TASKS
roof	poor	critical	Replace rolled roof and moisture barrier in 20' x 12' section; Use nails on site; Cover hatch with 3'x3' plywood; Adjust stovepipe and inspect flashing
wall structure	poor	critical	Monitor separation at the south wall to determine that it is stable or else identify the failure mechanism; Remove failed caulk and refill gaps at south corners
finishes	poor	critical	Test for lead content, scrape surfaces, apply two coats primer and paint (3 gallons each). Varnish interior door, trim, and lower walls (2 gallons).
catwalk	poor	urgent	Sister cracked joist with two 8' 2x10 boards; Replace 6' section of fascia with a 2x10; Restore original railing design and replace weakened parts: two 16' 2x4 rails, two 8'2x4 rails, three 4' 4x4 posts, eight 3/16 diameter thru bolts; Repair deck board with 3' 2x3; Reinforce with stairs with screws and trim bottom step.
ceiling	fair	urgent	Open ceiling to mitigate carpenter ant infestation; Inspect ceiling joists and rafters for moisture and insect damage; Repair ceiling: six 6' 3-1/4" x1/4" sections of beadboard
windows	fair	urgent	Alter shutter system to remove bolts through window sash; Repair sash with wood epoxy; Touch-up glazing putty; Install screen clips
exterior trim	fair	minor	Fill gaps with wood and caulk; Address south wall issues, then realign horizontal trim at corners and splice in sections on center: four 1' 1x3s and four 1' 2x4s.
site	good	minor	Use lumber to complete repairs, remove lumber racks from west catwalk
interior trim	good	minor	Repair scarred sills with wood epoxy; Remove non-original trim at south corners
security	good	minor	Secure operable window on the east elevation

Proposed Access

Roads

Waldo Mountain Lookout is located in the Middle Fork Ranger District of the Willamette National Forest and is accessed from the Salmon Lakes - Waldo Mountain Trailhead. The trailhead can be reached by driving 25 miles from the Middle Fork Ranger Station on OR-58-E, Salmon Creek Road (Forest Road #24), Forest Road #2417, and Forest Road #2424.

Roads are well maintained and signage is limited but sufficient all the way to Salmon Lakes - Waldo Mountain Trailhead. The trailhead is a wide shoulder on a gravel road. It offers room for approximately eight vehicles and is sufficient for a truck and trailer to turn around in.

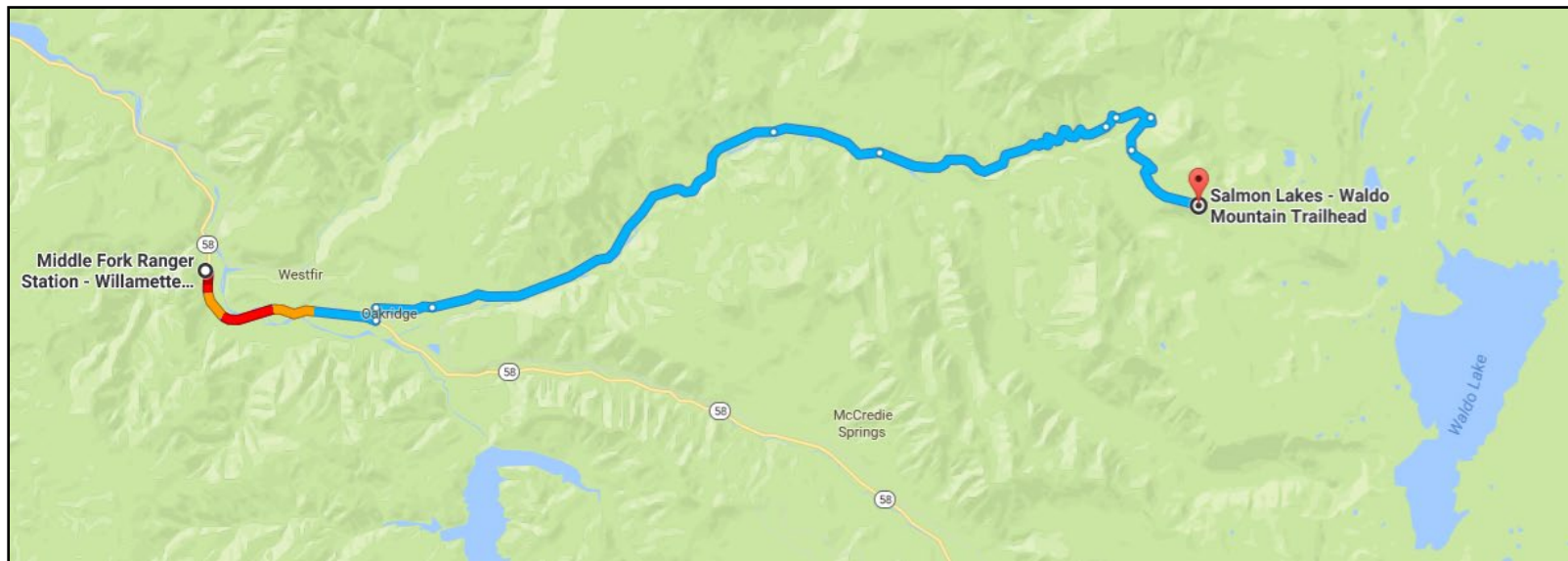

Route from Middle Fork Ranger Station to Salmon Lakes - Waldo Mountain Trailhead. Google Maps.

Trails

For this assessment the lookout was reached via the Waldo Mountain Trail (#3592) from the Salmon Lakes - Waldo Mountain Trailhead. This route is steep but well maintained and clearly signed all the way to the lookout. It climbs from approximately 4360' to 6360' over roughly 3 miles of trail. This route is the shortest and most direct way to reach Waldo Mountain Lookout, but alternative routes such as the Salmon Lakes trail and the east side of the Waldo Mountain Trail may offer useful water sources and camping sites. The lookout's coordinates are approximately 43.765304, -122.099002.

The Waldo Mountain Trail (#3592) has no reliable sources or significant stream crossings between the trailhead and the lookout. The most reliable water sources are provided by the Salmon Lakes, approximately 1.5 miles off the Waldo Mountain Trail. Depending on the year, snow banks may provide a water source closer to the lookout. Dispersed camping is allowed in the Waldo Lake Wilderness, but this trail does not offer any reliable camping sites. The ground is mostly steep and rocky. There is room for two small tents at the peak and two additional people could stay inside the building if it is not occupied by a fire watcher. A larger group might consider camping at the Salmon Lakes -Waldo Mountain trailhead, but would need to transport water.

Staging Materials

The recommended method for future work at Waldo Mountain would be a) a pack train from the Salmon Lakes - Waldo Mountain Trail or b) helicopter flights from an unidentified staging area.

Stock - The trailhead provides room for a horse trailer but may be difficult to turn around in. Waldo Mountain Trail is feasible for stock. It offers no places to water, graze, or camp with stock but the route is short. A small stock train could turn around by circling the lookout or turning on the ridge southeast of the peak.

Helicopters - Staging areas were not identified during this assessment, but several areas alongside Highway 58 are feasible. The trailhead is not a feasible staging area. A small ridge southeast of the lookout could provide enough room to drop and retrieve supplies.

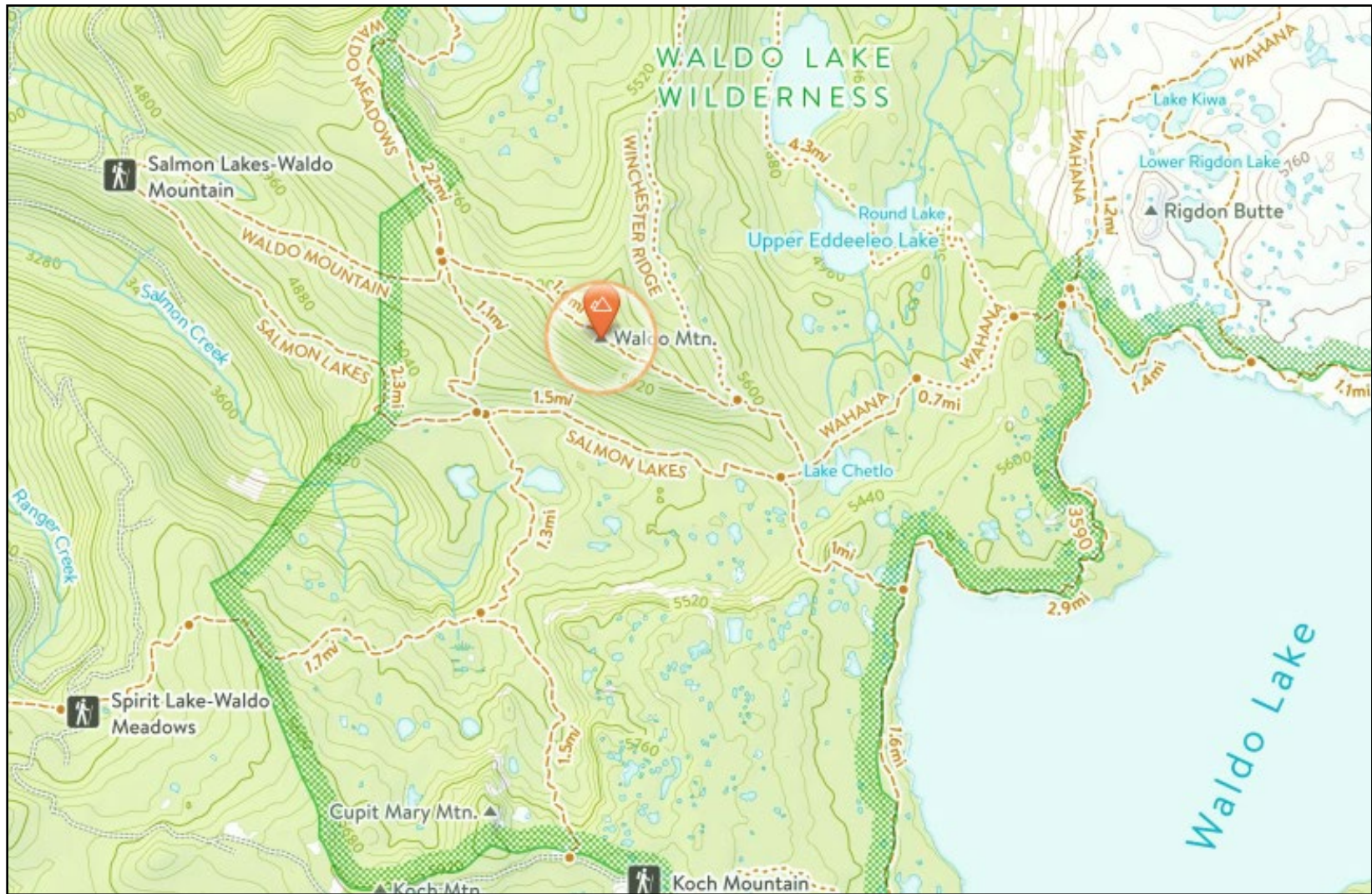

Map of Salmon Lakes - Waldo Mountain trailhead, Waldo Mountain Trail, and Waldo Mountain. www.naturalatlas.com.

REFERENCES CITED

Books

- Bergthaller, Hannes. "Paradox as Bedrock: Social Systems Theory and the Ungrounding of Literary Environmentalism in Edward Abbey's *Desert Solitaire*." in *Handbook of Ecocriticism and Cultural Ecology*, edited by H. Zapf. Boston: De Gruyter, 2016.
- Cronon, William. *Uncommon Ground: Rethinking the Human Place in Nature*. New York: W. W. Norton, 1995.
- Feldman, James W. *A Storied Wilderness: Rewilding the Apostle Islands*. Seattle: University of Washington Press, 2011.
- Gregory, Ian. *A Place in History: A Guide to Using GIS in Historical Research*. Oxford: Oxbow Books, 2003.
- Marsh, Kevin. *Drawing Lines in the Forest: Creating Wilderness Areas in the Pacific Northwest*. Seattle: University of Washington Press, 2007.
- Spence, Mark David. *Dispossessing the Wilderness: Indian Removal and the Making of the National Parks*. Oxford: Oxford University Press, 1999.
- Watt, Laura Alice. *The Paradox of Preservation: Wilderness and Working Landscapes at Point Reyes National Seashore*. Oakland: University of California Press, 2016.
- Williams, Gerald W. *The U.S. Forest Service in the Pacific Northwest*. Corvallis: Oregon State University Press, 2009.

Journal Articles

- Cronon, William. "The Riddle of the Apostle Islands." *Orion* 22, no. 3, (May/June 2003): 36-42.
- Carsley, Nikki C. "When Old Becomes New: Reconciling the Commands of the Wilderness Act and the National Historic Preservation Act." *Washington Law Review* 88, no. 2 (June 2013): 525-58.
<https://digitalcommons.law.uw.edu/wlr/vol88/iss2/8>.
- Chellis, Christopher. "Playing Nice in the Sandbox: Making Room for Historic Structures in Olympic National Park." *Washington Journal of Environmental Law & Policy* 7, no. 1 (June 2017): 35-64. <https://digitalcommons.law.uw.edu/wjelp/vol7/iss1/3>.

- Cowley, Jill, Peter Landres, Melissa Memory, Doug Scott, and Adrienne Lindholm. "Integrating Cultural Resources and Wilderness Character." *Park Science: Integrating Research and Resource Management in the National Park Service* 28, no. 3 (Winter 2011-2012): 29-33.
https://www.fs.fed.us/rm/pubs_other/rmrs_2012_cowley_j001.pdf.
- Garfinkel, Susan. "Recovering Performance for Vernacular Architecture Studies." *Perspectives in Vernacular Architecture* 13, no. 2 (2006): 106-14.
<https://www.jstor.org/stable/20355387>
- Landres, Peter, Judy Alderson, and David J. Parsons. "The Challenge of Doing Science in Wilderness: Historical, Legal, and Policy Context." *The George Wright Forum* 20, no. 3 (2003): 42-9.
https://www.fs.fed.us/rm/pubs_other/rmrs_2003_landres_p001.pdf.
- Landres, Peter, Wade M. Vagias, and Suzy Stutzman. "State of Science: Using Wilderness Character to Improve Wilderness Stewardship." *Park Science: Integrating Research and Resource Management in the National Park Service* 28, no. 3 (Winter 2011-2012): 44-8.
https://www.fs.fed.us/rm/pubs_other/rmrs_2012_landres_p001.pdf.
- Nagle, John Copeland. "Wilderness Exceptions." *Environmental Law* 44 (Spring 2014): 373-414. <https://www.jstor.org/stable/i40129006>.
- Rose, Jeff and Dan Dustin. "Through the Looking Glass: What Value Will We See in Wilderness in 2064?" *Park Science: Integrating Research and Resource Management in the National Park Service* 28, no. 3 (Winter 2011-2012): 106-7.
<https://irma.nps.gov/Datastore/Reference/Profile/2017906>.

Academic Papers

- Blecha, Erika S. "Into the Wild: A Case Study of the Intersection of Archaeology and Federal Wilderness Policy." MA Thesis, University of Montana, 2015.
- Christensen, Kelly Marie. "Wilderness Values, The Environmental Movement, and Mission 66." MA Thesis, University of Oregon, 2011.
- Gathers, Kerry. "Old Buildings and the New Wilderness: The Politics of Conservation in Cumberland Island, Georgia." MA Thesis, University of Georgia, 2006.
- Hill, John. "All Along the Watchtower: Identifying Trends in Historic Fire Lookout Preservation Through Selected Case Studies and Statistical Analysis." M.S. Historic Preservation Terminal Project, University of Oregon, 2013.

Kirn, Laura. "A Case for Storied Landscapes: Wilderness and Historic Preservation." MA Thesis, Goucher College, 2013.

Swing, Alison E. "Cultural Wilderness: How the Historical Evolution of American Wilderness Values Influence Cultural Resource Management within Wilderness Areas in National Parks." MA Thesis, University of Pennsylvania, 2011.

Ryan, Molly Michelle, "The House That Smokey Built: The USDA Forest Service Management of Historic Structures in Wilderness." MA Thesis, University of Montana, 2009.

Wells, Jeremy C. 2010. "*Valuing Historic Places: Traditional and Contemporary Approaches.*" Paper presented at Preservation and Rehabilitation of Iraqi City Centers, Baghdad, Iraq, March 22-27, 2010. docs.rwu.edu/saahp_fp.

Government Publications

Advisory Council on Historic Preservation. *Policy Statement on Balancing Cultural and Natural Values on Federal Lands*. 2002. Accessed February 20, 2020.
<https://www.achp.gov/digital-library-section-106-landing/achp-policy-statement-balancing-cultural-and-natural-values>.

Arthur Carhart Wilderness Training Center. *Minimum Requirements Decision Guide and Instructions*. 2016. Accessed February 20, 2020.
https://winapps.umt.edu/winapps/media/2/wilderness/NWPS/documents/MRDG/MRDG_instructions.pdf.

Arthur Carhart Wilderness Training Center. National Wilderness Steering Committee. *Guidance Paper Number 1: Cultural Resources and Wilderness*. 2002. Accessed February 20, 2020.
<https://www.nps.gov/apis/learn/management/upload/crmandw.pdf>

U.S. Department of Agriculture. Forest Service. *Cultural Resource Inventory form: Cairn Basin Shelter*, by Jon Horn. Mount Hood National Forest, 1978.

——— *Cultural Resource Inventory form: Cooper Spur Shelter*, by Jon Horn. Mount Hood National Forest, 1978.

——— *Cultural Resource Inventory form: Devil's Peak Lookout*, by Jon Horn. Mount Hood National Forest, 1978.

——— *Cultural Resource Inventory form: Elk Cove Shelter*. Mount Hood National Forest, 1980.

- *Cultural Resource Inventory form: Elk Meadows Shelter*, by Jon Horn. Mount Hood National Forest, 1978.
- *Cultural Resource Inventory form: High Prairie Cabin*. Mount Hood National Forest, 1980.
- *Cultural Resource Inventory form: Gnarl Ridge Shelter*, by Jon Horn. Mount Hood National Forest, 1978.
- *Cultural Resource Inventory form: Kinzel Mine and Cabin*, by Jon Horn. Mount Hood National Forest, 1978.
- *Cultural Resource Monitoring Report: Kinzel Cabin*, by Grady Caulk. Mount Hood National Forest, 1997.
- *Cultural Resource Site Report: Waldo Mountain Lookout*, by C. Winkler, C. Martin, and K. Ranisate. Willamette National Forest, 1993.
- *Determination of Eligibility: Bull of the Woods Lookout*, by Jill Bassett. Mount Hood National Forest, 1993.
- *Devil's Peak Lookout Condition Assessment*, by Pete Cecil. Mount Hood National Forest, 1993.
- *Historic American Building Survey: The Horse Ranch, Eagle Cap Wilderness Area, Joseph, Wallowa County, OR*, by Sally Donovan and Kimberley Lakin. Wallowa-Whitman National Forest, 1996.
- *Historic Fire Lookouts on the Siskiyou National Forest: Cultural Property Inventory and Request for a Determination of Eligibility to the National Register of Historic Places*, by Katherine Atwood. Siskiyou National Forest, 1994.
- *Historic Fire Lookouts on the Willamette National Forest: A Determination of Eligibility to the National Register of Historic Places*, by James B. Cox. Willamette National Forest, 1991.
- *Historic Structures in Oregon Wilderness*, by Charlotte Helmer, HistoriCorps. Pacific Northwest Region, 2018.
- *Historical Sketches of the Wallowa National Forest*, by Gerald J. Tucker, Wallowa National Forest, 1954.
- *Minimum Requirement Decision Guide: Cultural Resource Condition Assessments for Historic Structures*. Pacific Northwest Region, June 2017.

- *National Register of Historic Places Registration Form: Timberline Trail*, by Gail Throop. Pacific Northwest Region, 1988.
- *National Register of Historic Places Registration Form: Upper Sandy Guard Station*, by Jan M. Tomlinson, Northwest Forest Conservancy, 2009.
- *National Register of Historic Places Registration Form: USDA Forest Service Historic Structures on the Rogue River National Forest*, by Katherine Atwood. Rogue River National Forest, 2000.
- *Section 106 Documentation form: Devil's Peak Lookout*, by Jeff Jaqua. Mount Hood National Forest, 2002.
- *Standley Guard Station Preservation Project: A Heritage Resource Consultation Report*, by Jacqueline Beidl. Wallowa-Whitman National Forest, 2003.
- *Utility and Service Combined with Beauty: A Contextual and Architectural History of the USDA Forest Service Region 6: 1905-1960*, by Kay Atwood, Sally Donovan, Dennis Grey, and Ward Tonsfeldt. Pacific Northwest Region, 2005.
- U.S. Department of Agriculture. Forest Service. Interagency Wilderness Character Monitoring *Keeping It Wild: An Interagency Strategy to Monitor Trends in Wilderness Character Across the National Wilderness Preservation System*, by Peter Landres, Chris Barns, John G. Dennis, Tim Devine, Paul Geissler, Curtis S. McCasland, Linda Merigliano, Justin Seastrand, and Ralph Swain.. 2008. Accessed February 20, 2020. https://www.fs.fed.us/rm/pubs/rmrs_gtr212.pdf.
- *Keeping It Wild 2: An Updated Interagency Strategy to Monitor Trends in Wilderness Character Across the National Wilderness Preservation System*, by Peter Landres, Chris Barns, Steve Boutcher, Tim Devine, Peter Dratch, Adrienne Lindholm, Linda Merigliano, Nancy Roeper, and Emily Simpson. 2015. Accessed February 20, 2020. https://www.fs.fed.us/rm/pubs/rmrs_gtr340.pdf.
- U.S. Department of the Interior. National Park Service. National Register of Historic Places. *How to Apply the National Register Criteria for Evaluation*. 2002. Accessed February 20, 2020. https://www.nps.gov/subjects/nationalregister/upload/NRB-15_web508.pdf.
- U.S. Department of the Interior. National Park Service. Technical Preservation Services. *Preservation Brief 17: Architectural Character—Identifying the Visual Aspects of Historic Buildings as an Aid to Preserving their Character*. 1988. Accessed February 20, 2020. <https://www.nps.gov/tps/how-to-preserve/briefs/17-architectural-character.htm>.

——— *The Secretary of The Interior’s Standards for The Treatment of Historic Properties with Guidelines for Preserving, Rehabilitating, Restoring & Reconstructing Historic Buildings*. 2017. Accessed February 20, 2020.
<https://www.nps.gov/tps/standards/treatment-guidelines-2017.pdf>.

U.S. Department of the Interior. National Park Service. Wilderness Stewardship Division. *Keeping It Wild in the National Park Service: A User Guide to Integrating Wilderness Character into Park Planning, Management, and Monitoring*. 2014. Accessed February 20, 2020.
https://www.fs.fed.us/rm/pubs_other/rmrs_2014_landres_p001.pdf.

Spatial Data

Wilderness Connect. “Wilderness Data and National Wilderness Preservation System Map.” Accessed March 10, 2017. www.wilderness.net/map.cfm.

U.S. Department of Agriculture. Forest Service. Geospatial Data Discovery. “Administrative Forest Boundaries.” Accessed March 10, 2017.
<https://enterprisecontent-usfs.opendata.arcgis.com>.

U.S. Department of Agriculture. Forest Service. Natural Resources Manager, Infrastructure database. Personal correspondence with Charles Ruhsenberger, Regional Facilities Program Assistant, Pacific Northwest Region in March 2016.

Websites

Oregon Wild. “Wilderness Across Oregon,” map. Accessed March 10, 2017.
<https://oregonwild.org/wilderness/wilderness-across-oregon>.

——— “Wilderness Fact Sheet.” Accessed March 10, 2017.
https://oregonwild.org/sites/default/files/pdf-files/Wilderness_Fact_Sheet.pdf

Wilderness Connect. “Advanced Wilderness Search” database. Accessed March 10, 2017. <https://wilderness.net/practitioners/wilderness-areas/search.php>.

——— “Law Search” database. Accessed March 10, 2017.
<https://wilderness.net/practitioners/law-regulation/law/law-search/default.php>.

——— “Wilderness Areas of the United States” map. Accessed March 10, 2017.
<http://www.wilderness.net/map.cfm>.