



Passive Heated Building Proposals Winter 2017 • Passive Heating Building Analysis

Craig Speck • Architecture

Alexandra Rempel • Assistant Professor • Environmental Studies

Acknowledgements

The authors wish to acknowledge and thank the University of Oregon's Environmental Studies Program and the City of Albany's Parks and Recreation Department for making this project possible. We would also like to thank the following Albany Staff for their assistance and contributions that were instrumental to the completion of this report.

Ed Hodney, Albany Parks & Recreation Director, Parks & Recreation Department

Bob Richardson, Planning Manager, Community Development Department

About SCI

The Sustainable Cities Initiative (SCI) is a cross-disciplinary organization at the University of Oregon that promotes education, service, public outreach, and research on the design and development of sustainable cities. We are redefining higher education for the public good and catalyzing community change toward sustainability. Our work addresses sustainability at multiple scales and emerges from the conviction that creating the sustainable city cannot happen within any single discipline. SCI is grounded in cross-disciplinary engagement as the key strategy for improving community sustainability. Our work connects student energy, faculty experience, and community needs to produce innovative, tangible solutions for the creation of a sustainable society.

About SCYP

The Sustainable City Year Program (SCYP) is a year-long partnership between SCI and one city in Oregon, in which students and faculty in courses from across the university collaborate with the partner city on sustainability and livability projects. SCYP faculty and students work in collaboration with staff from the partner city through a variety of studio projects and service-learning courses to provide students with real-world projects to investigate. Students bring energy, enthusiasm, and innovative approaches to difficult, persistent problems. SCYP's primary value derives from collaborations resulting in on-the-ground impact and expanded conversations for a community ready to transition to a more sustainable and livable future.

SCI Directors and Staff

Marc Schlossberg, SCI Co-Director, and Associate Professor of Planning, Public Policy, and Management, University of Oregon

Nico Larco, SCI Co-Director, and Associate Professor of Architecture, University of Oregon

Megan Banks, SCYP Manager, University of Oregon



About Albany, Oregon

The city now known as Albany has an established history as a central hub in the Willamette Valley. Founded in 1848 and incorporated in 1864 the city has served as the Linn County seat since 1851. Albany's unique place in Oregon's history is exemplified in its dedication to historical preservation. Albany is often noted to have the most varied collection of historic buildings in Oregon. Its "four historic districts are listed in the National Register of Historic Places by the United States Department of the Interior." This downtown core has served as the center of revitalization efforts since 2001.

Located on the Willamette and Calapooia rivers Albany spans both Linn and Benton counties. With a population of 51,720 people, Albany is Oregon's 11th largest city and the second largest city in Benton County. Albany is administered under a home rule charter, adopted in 1957 establishing a Council and City Manager model. The city's vision, to be a "vital and diverse community that promotes a high quality of life, great neighborhoods, balanced economic growth and quality public services," is exemplified by its administration and government. Albany has a very active civic community with nearly 100 citizens serving on advisory commissions and committees dedicated to municipal issues.

Historically, Albany's economy has relied on natural resources. As the self-styled "rare metals capital of the world," Albany produces zirconium, hafnium and titanium. Major employment sectors include "wood products, food processing, and manufactured homes." Because of its short, dry temperate growing season Albany farmers excel in producing specialized crops like grass flower and vegetable seeds, "tree fruits, nursery stock, nuts, berries, mint and grains." Albany and the surrounding (Linn and Benton) counties are so agriculturally productive it is often called "The Grass Seed Capital of the World."

Albany's central location and mild climate has made it a popular destination for a variety of outdoor and leisure activities. Located in the heart of Oregon's most populous region with the Pacific coast to the west and the Cascade Range to its east, Albany is connected to the wider state by Interstate 5, Oregon Routes 99E and 34, and US Route 20. The city is also served by Amtrak, a municipal airport, and a local and regional bus network.

Course Participants

Eric Barth, Architecture Graduate
Travis Blunt, Architecture Undergraduate
Kayla Bundy, Architecture Undergraduate
Jordan Frazin, Architecture Graduate
Jacqueline Greazzo, Architecture Undergraduate
Sean Henderson, Architecture Undergraduate
Lindsay Jacobson, Architecture Graduate
Zhengxian Jin, Architecture Graduate
Alex Kendle, Architecture Graduate
Chazandra Kern, Architecture Graduate
Kelli Kimura, Architecture Undergraduate
Ashley Kopetzky, Architecture Graduate
Shradhan Shrivastav, Architecture Graduate
Serena Lim, Architecture Graduate
Andrew Loia, Architecture Graduate
Fiona Lui, Architecture Undergraduate
Steven Llang, Architecture Undergraduate
Dristi Manandahar, Architecture Graduate
Scotty McClelland, Architecture Graduate
Ana Misenas, Architecture Graduate
May Nguyen, Architecture Graduate
Danielle Pomeroy, Architecture Undergraduate
Isabel Rivera Architecture Graduate
Craig Speck, Architecture Graduate
Lindsay Suprenant, Architecture Graduate
Hien Vo, Architecture Graduate
Kayla Zander, Architecture Graduate

This report represents original student work and recommendations prepared by students in the University of Oregon's Sustainable City Year Program for the City of Albany. Text and images contained in this report may not be used without permission from the University of Oregon.

Table of Contents

Course Participants	5
Executive Summary	7
Monteith Park Restrooms	9
Passive Solar Restrooms	16
Monteith Park Public Restrooms	25
Sunroom Designs	33
Community Sunroom	44
Pollinator Protection	51
Considerations for Design Development	64

Executive Summary

The City of Albany looked to University of Oregon architecture students to gather climate and microclimate information for Monteith Park and use it to quantify local heating needs and monthly net solar heating resources. Student teams developed passive solar designs for park restrooms, a sunspace off the current senior center, and a greenhouse, incorporating spatial, experiential, and computational components on selected buildings and sites with the City of Albany. Students and faculty collaborated with city staff to help realize the goals of the project.

Students carried out a site analysis focusing on the climate, microclimate, and any ecologies that could affect their designs. Understanding the site's sun exposure and shading were key components to producing a well-informed design. A device called a "Solar Pathfinder" was used to determine site solar exposure and shading. Shading masks were produced to visually show how surrounding trees and structures could inhibit solar collection on a site.

Off-site study mainly focused on the use of EnergyPlus, a software used to run simulations for passively heated design. Climate data from the region was used to obtain the site's monthly solar resource and solar radiation levels. Using Climate Consultant, students studied how tilting surfaces could vary solar gain results. The "max tilt" was found to gather the maximum solar radiation during winter months. Most projects had a max tilt between 23 and 35 degrees.

Common elements in design proposals included: Direct and indirect solar gain to extend the thermal comfort season into March and November; adaptable and climate oriented buildings; accessible and inclusive spaces; low cost buildings; and moveable insulation. Student designs successfully extended the thermal comfort season utilizing proper thermal mass, windows, and insulation. The use of moveable insulation was an important aspect of this project and made a notable difference in performance. However, proper performance of moveable insulation relies heavily on a quality seal around its edges. If a proper seal cannot be maintained, moveable insulation should not be used.

Monteith Park Restrooms

Designers: Kayla Bundy, Hieu Vo, Kelli Kimura

Design Intention

The main goal of our design is to create a passively heated restroom that is a place of refuge from the chilly wind, unrelenting drizzle, and the intense heat of summer. We want to increase the number of months where park goers can comfortably use the restroom. We intend to provide good solar exposure from February through November, especially in the morning and afternoon when the park is most used. This will allow for more warmth from the sun in early spring and late fall when the weather is often chilly. For our analysis we focused on creating a restroom that can remain open without freezing from February through May. This would also likely increase temperatures in the chilly months of September to November. Appropriate shading will prevent overheating in summer months. The restroom will then become a cool, inviting escape. We intend for ours to also be a place of relief in terms of thermal comfort. The location of the restroom was chosen to maximize visibility and convenience. Moving it towards the parking lot and playground allows for ease of access for both children playing and audiences watching a performance at the amphitheater. Being near the edge of the park also allows for increased visibility at night and moves the restroom mostly out of the flood zone.

We intend for the restroom to feel safe, inclusive and appealing, unlike many public restrooms. Using warm colored materials that contrast with the monotonous gray of winter will support this. At the same time, we want to use materials that weather well and can be exposed to water in the case of an extreme flood event. The use of concrete walls and a concrete floor will achieve this. The restroom and paths leading to it will be easily used and ADA compliant. In the warmer months, inlets/outlets will allow the space to be adequately naturally ventilated. The ventilation will be controlled by a simple system that opens the windows when the interior temperature of the restroom reaches 75 degrees Fahrenheit. Clerestory windows on the north wall will bring in natural daylight, helping the structure feel more open while maintaining necessary privacy. Light from these windows and the skylight will bring a sense of delight.

We hope that our design enhances the park going experience all year round: Becoming a beacon of warmth on a chilly, dreary day or a refreshing haven from the beating sun.

Data

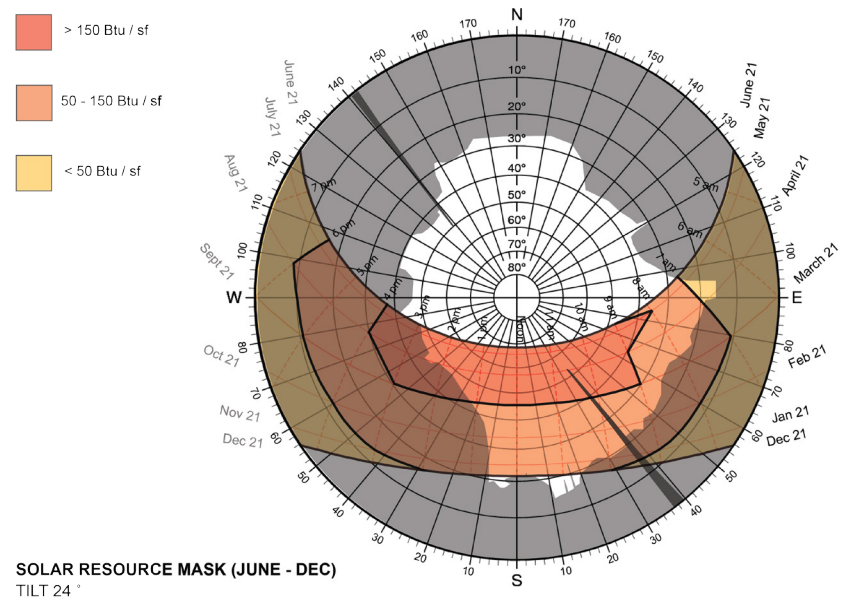
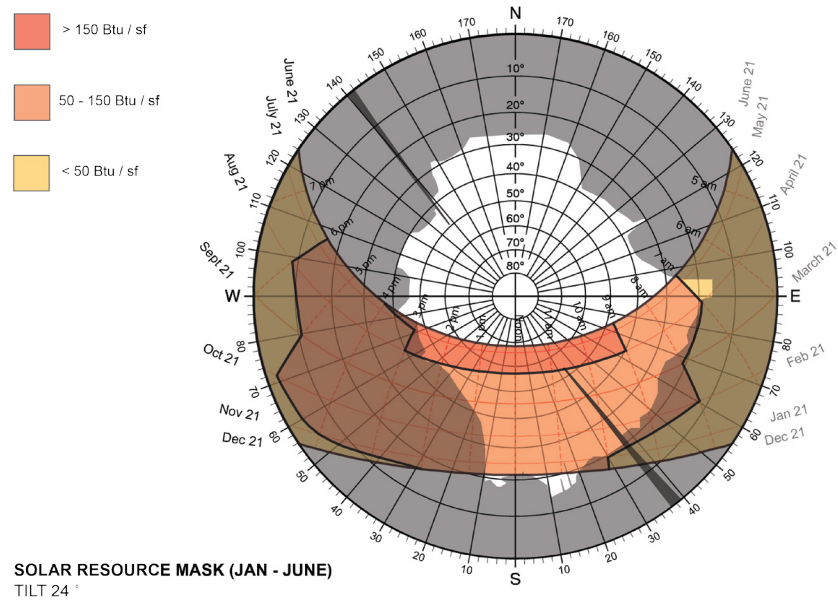

Figure 2 : Solar Radiation

Corvallis Monthly Solar Radiation

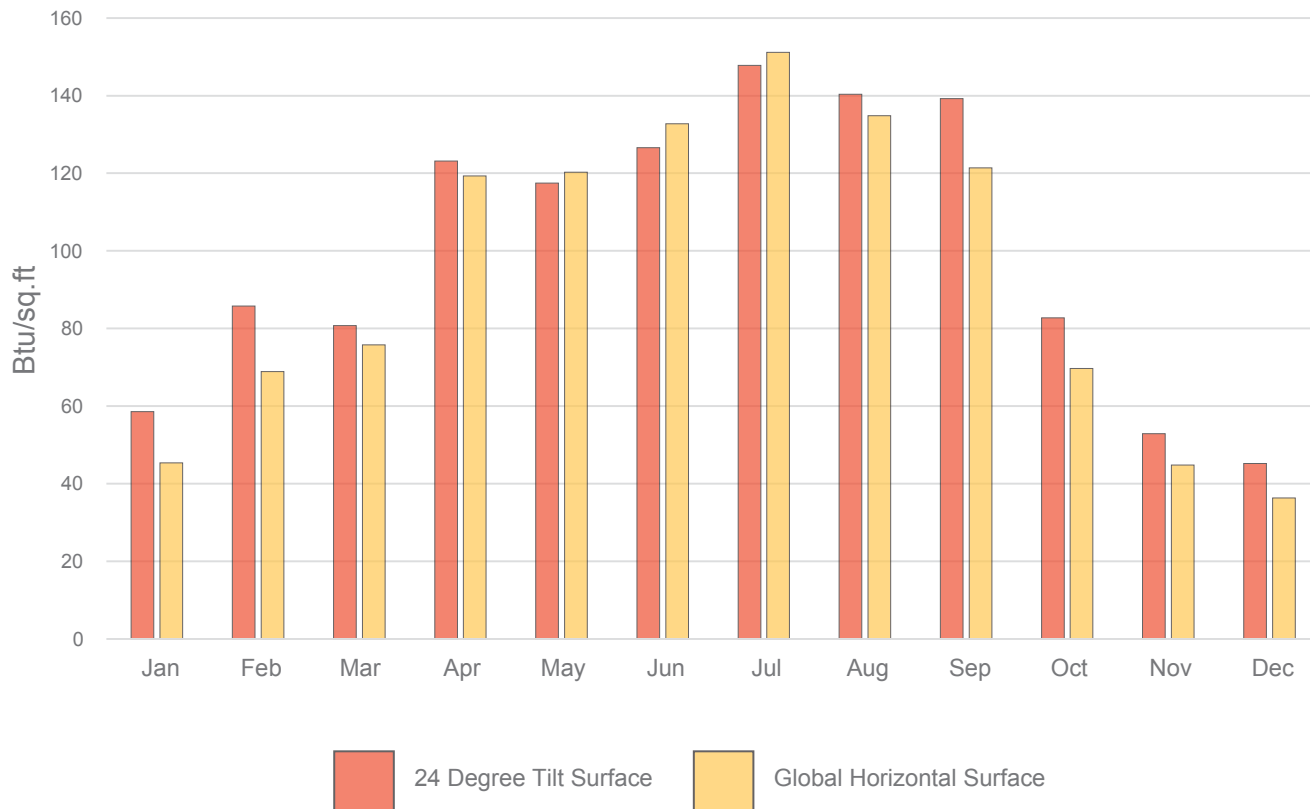

Figure 3: Solar Radiation Chart

Data

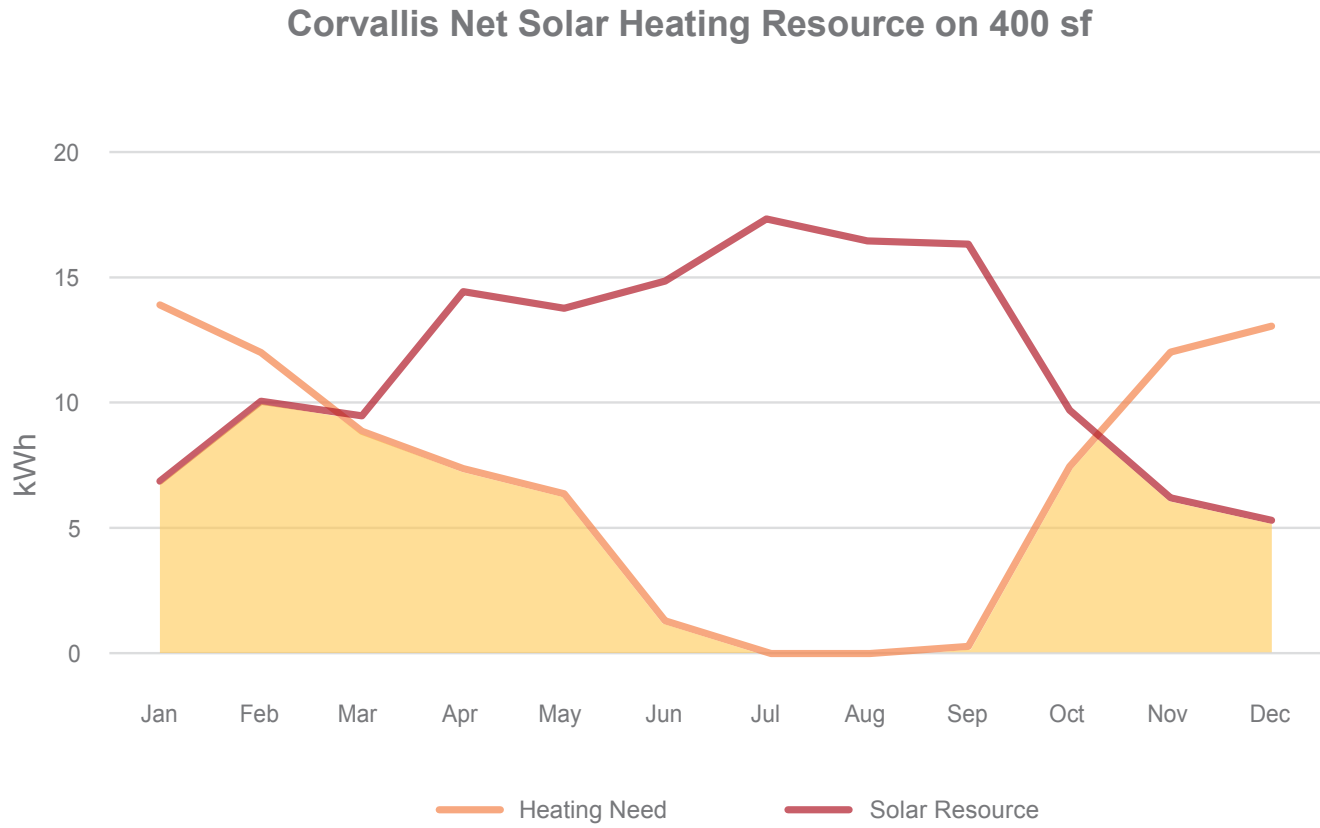

Figure 4: Heating Resource Chart (on 400sf)

Design

MATERIAL CHOICE:

- **Gypsum board** - cost effective
- **Asphalt Shingles** - cost effective
- **Concrete** - durability, thermal mass
- **Fiberboard Sheathing** - can be painted
- **Trombe Wall** - absorb and store heat
- **Wood Panel Movable Insulation** - add warmth to material palette

12

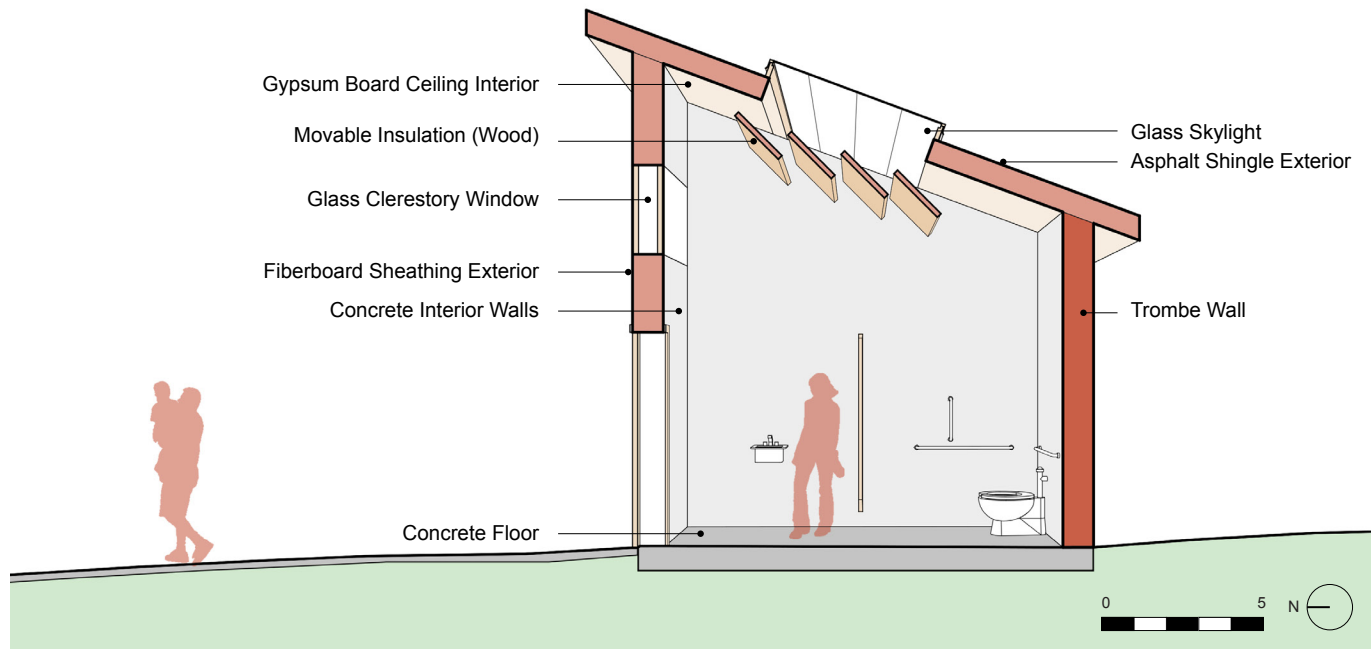

Figure 5: Section

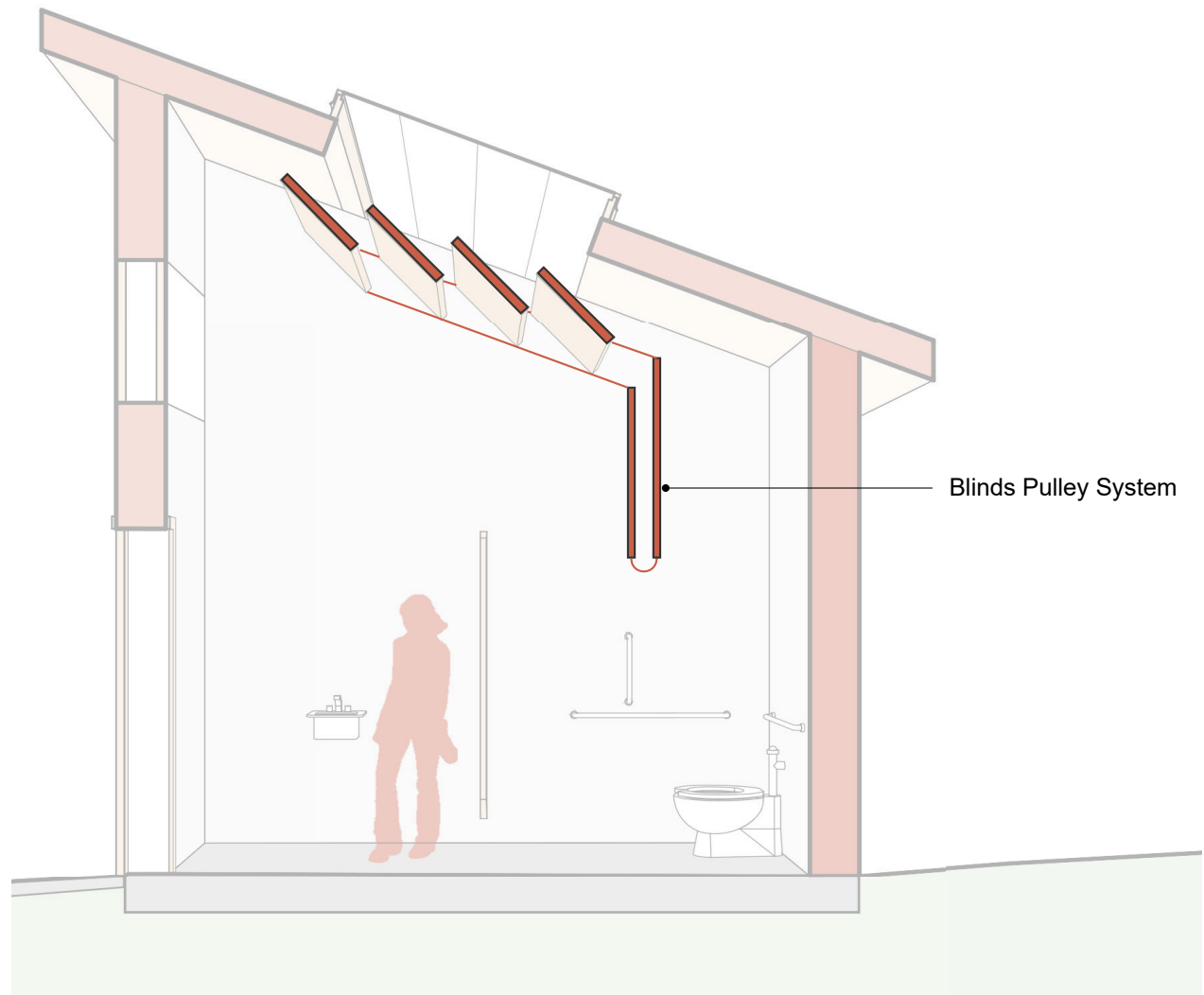

Figure 6: Movable Insulation Section

Results

14

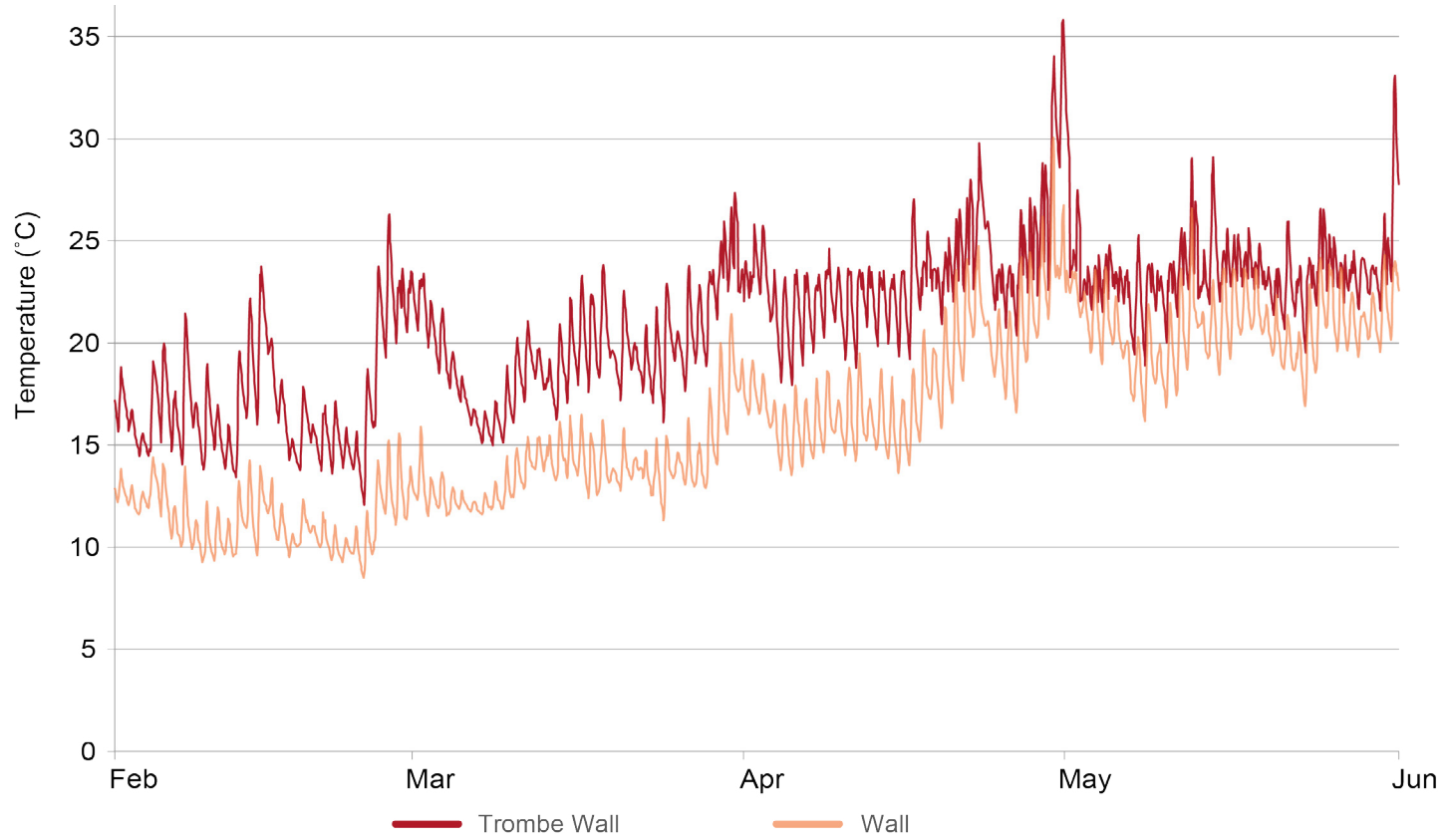

Figure 7: Restroom Air Temperature (hourly)

Passive Solar Restrooms

Designers: Serena Lim, Andrew Loia

Design Intention

Our primary design goal for the Monteith Riverpark restroom is to create a delightful space for public use. We intend for park visitors to discover thermal delight in the comfortable temperature of the restroom's interior, relative to outdoor temperatures, during the hot and cold seasons. Natural ventilation is intended to maintain fresh air and avoid stuffiness inside the restroom, while translucent wall panels in the restroom's "sunspace" create a glowing, visually delightful, daylit space. The addition of solar heated hot water for handwashing provides another thermally delightful experience. The increased efficiency of these strategies combined makes conventional mechanical and HVAC equipment unnecessary, reducing the energy demands and operational costs of the restroom.

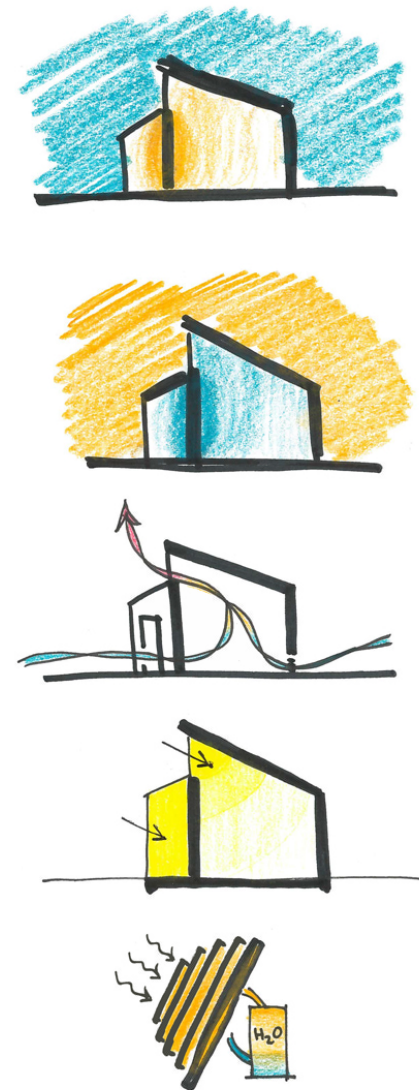

Figure 8: Intention Diagrams (Lim and Loia)

Site Selection

16



Figure 9: Site Plan and Solar Analysis

Site Selection

CLIMATE & RESOURCES

SOLAR RESOURCE MAP W/ SHADING MASK

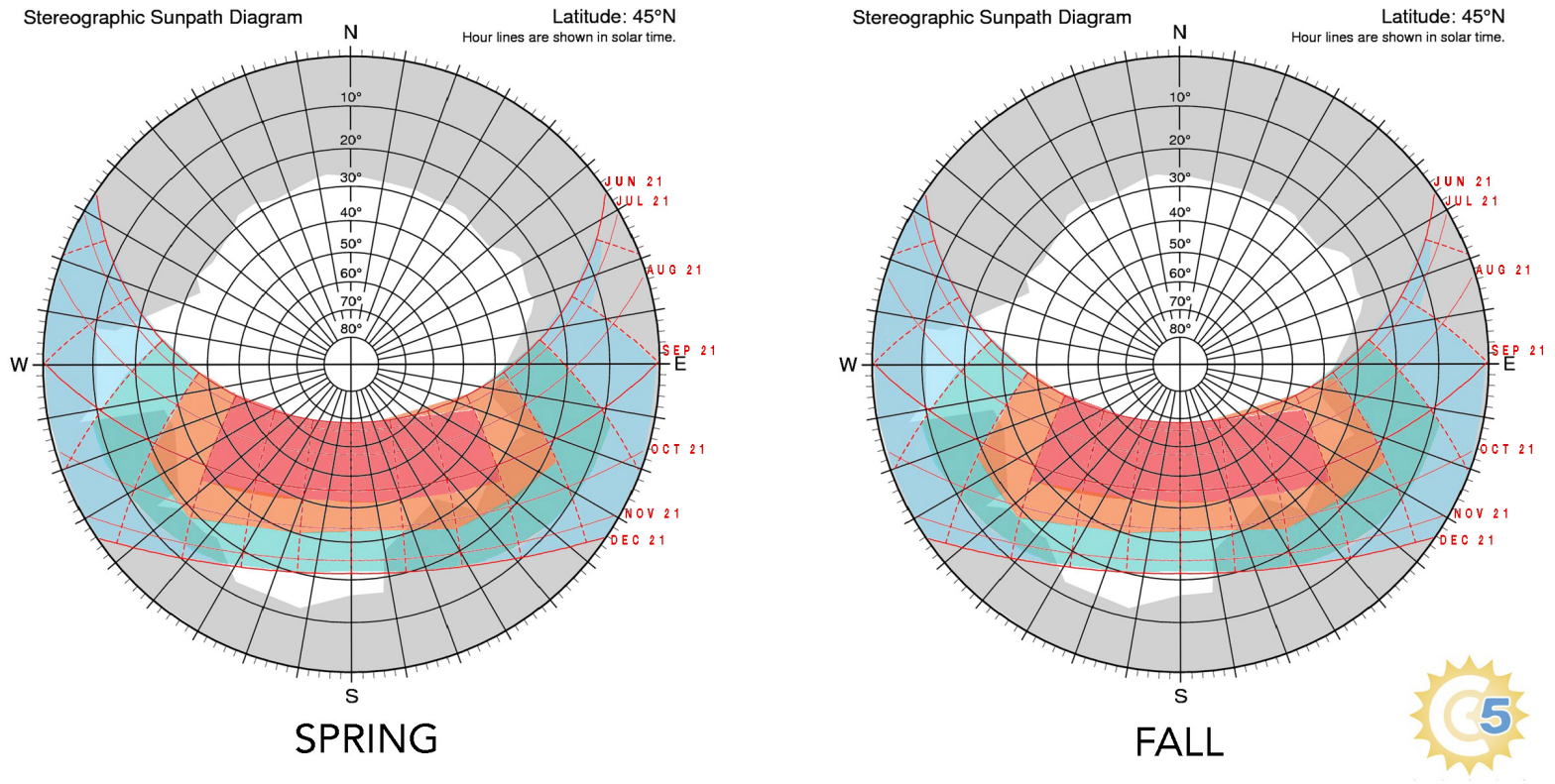

Figure 10: Shading

Design

18

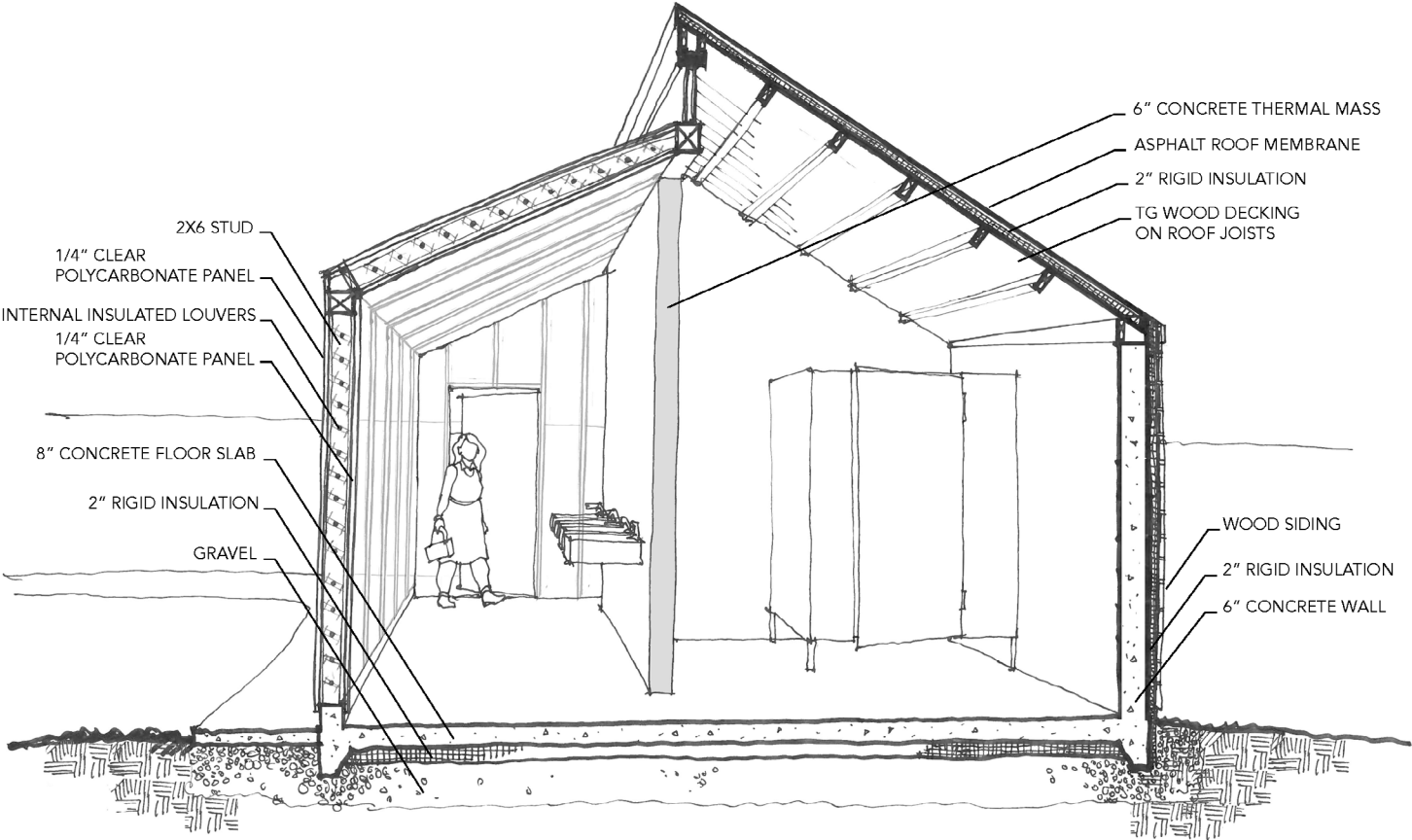
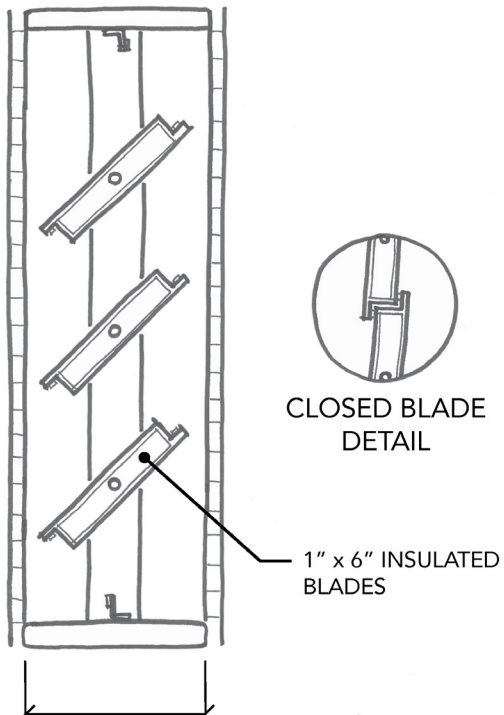

Figure 11: Section



CONCEALED, IN-CHANNEL LOUVERS

POLYURETHANE SEALS

R-VALUE = 4; U-VALUE = 0.25 Btu/(hr•sf•°F)

EXTERNALLY OPERATED
(Opportunity for connection)



Figure 12: Movable Insulation

Results - Movable Insulation - March 1

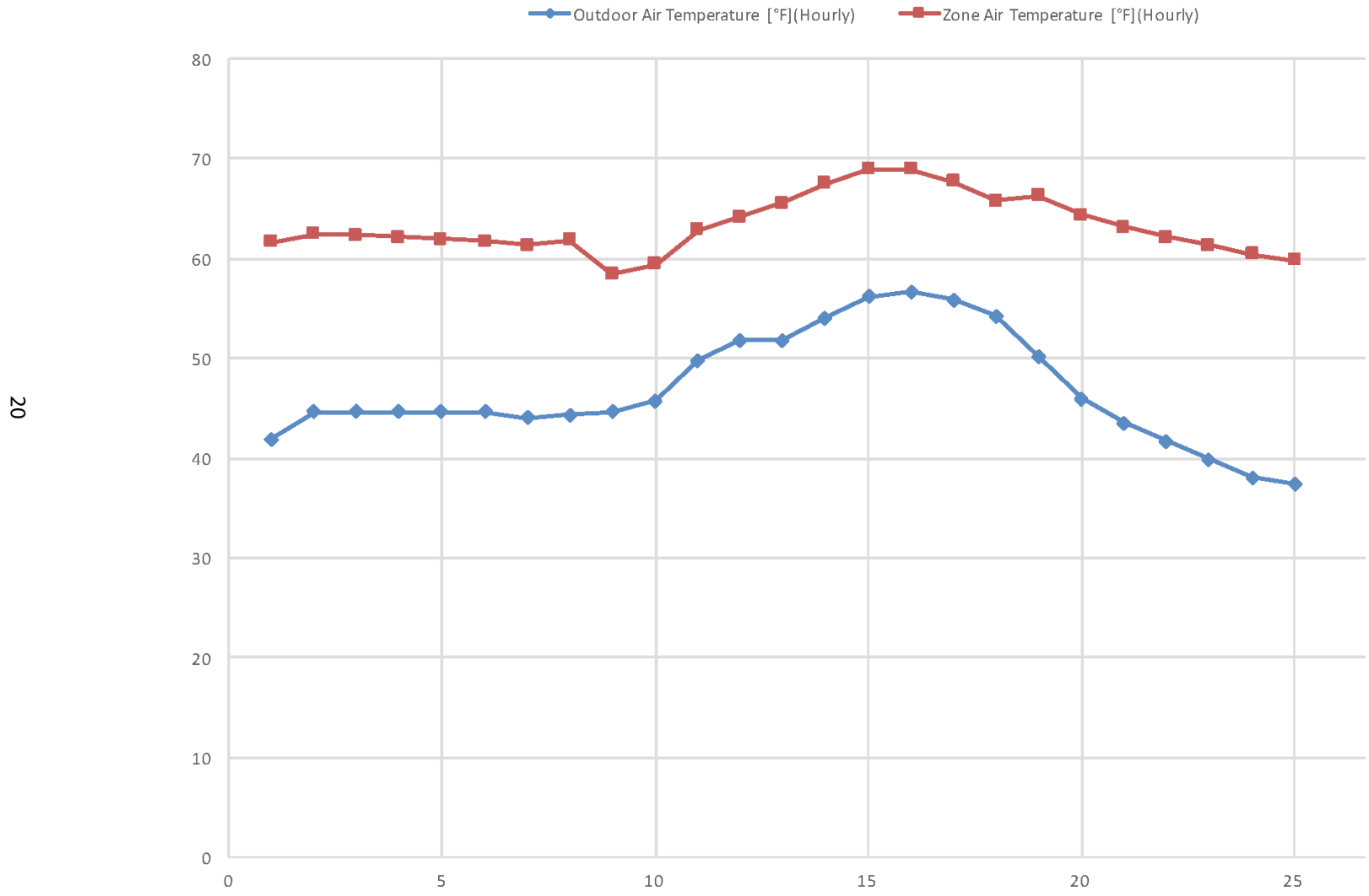

Figure 13: Performance Simulations (Movable Insulation - March

Results - No Movable Insulation - March 1

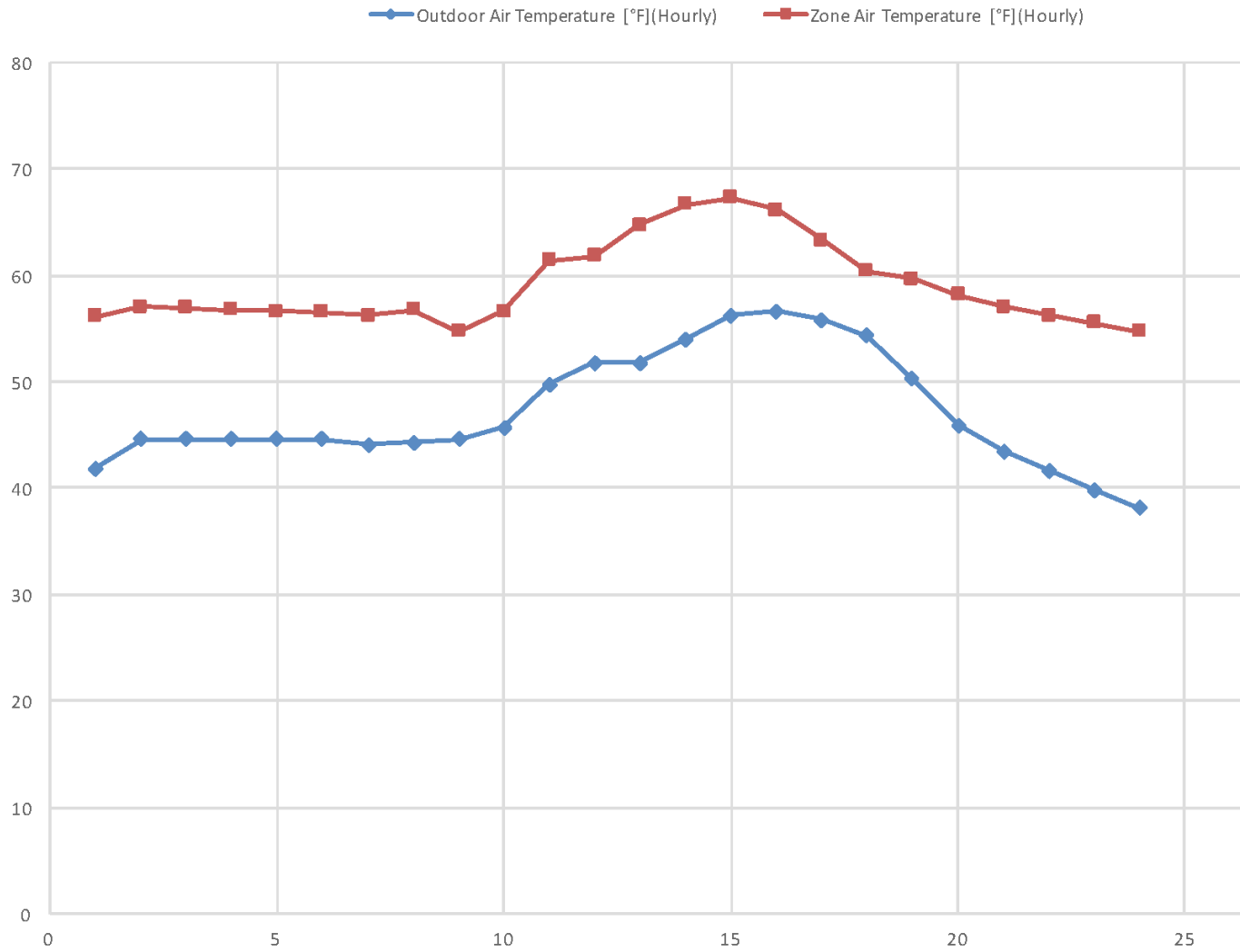

Figure 14: Performance Simulations (No Movable Insulation - March

Results - Limited Ventilation - March 1

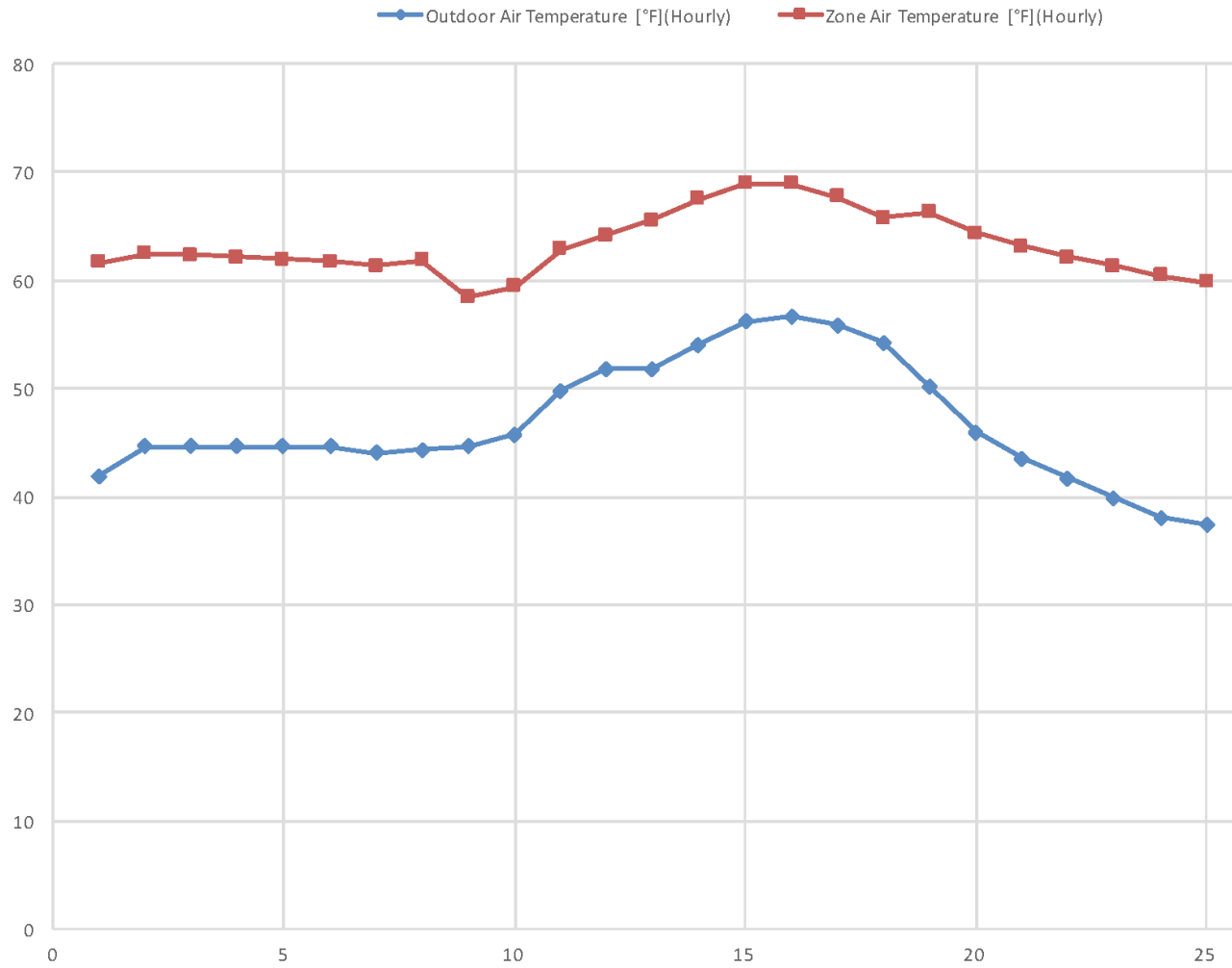

Figure 15: Performance Simulations (Limited Ventilation - March 1)

Results - High Ventilation - March 1

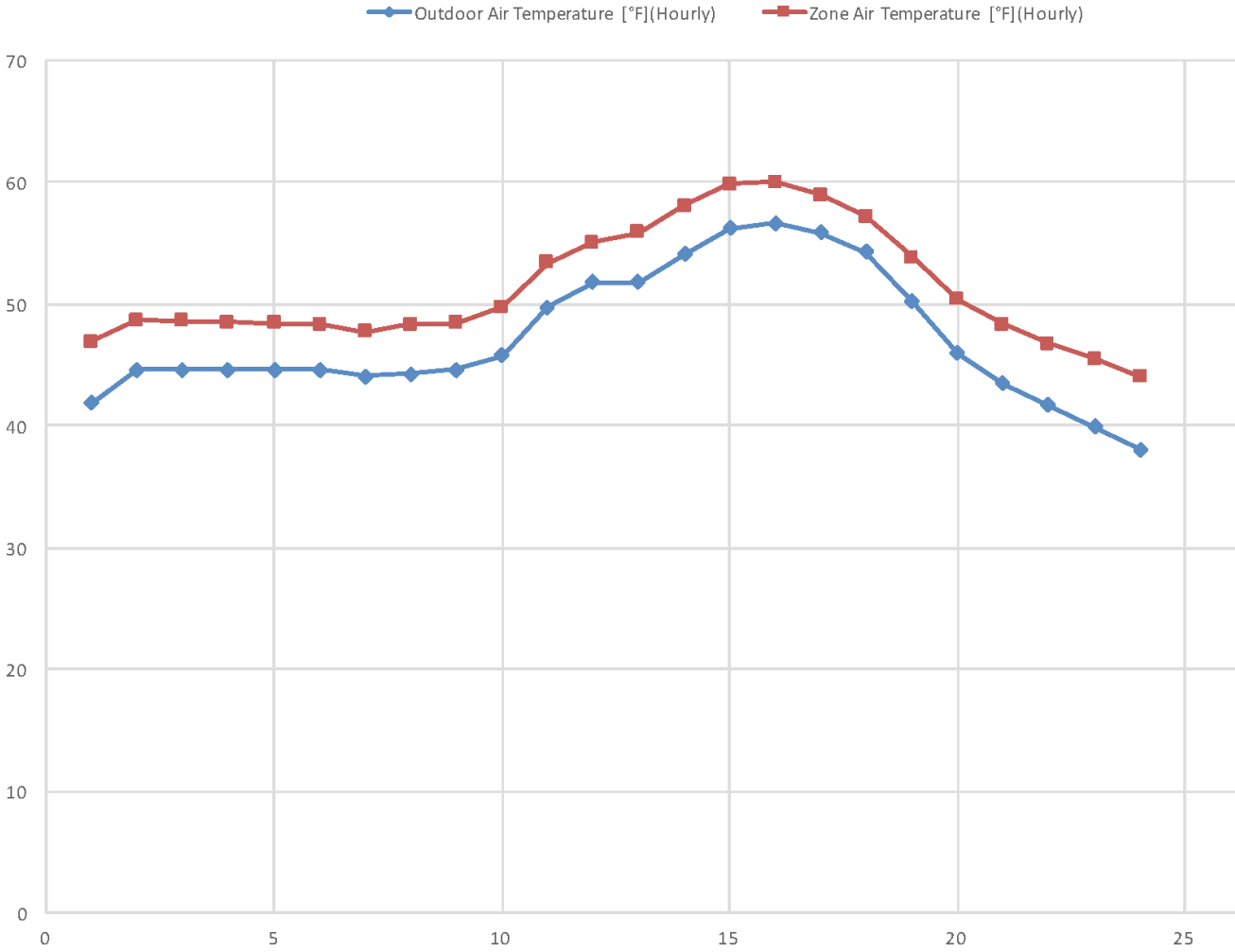

Figure 16: Performance Simulations (High Ventilation - March

Monteith Park Public Restrooms

Designers: Lindsay Jacobson, Craig Speck

Design Intention

Environmentally Sustainable
Passive Heating

- Indirect solar gain (sun room)
- Extend thermal comfort season: Mar. and Nov.

Ecologically Responsive

- Flood adapted
- Climate oriented

Economically Sustainable
Simple Construction

- Modular
- Low-cost maintenance
- Locally available materials
- Resilient

Socially Sustainable
Universally Accessible

- Ramp access
- ADA Amenities

Inclusive

- Sheltered Space
- Family/Gender neutral space

Site Selection

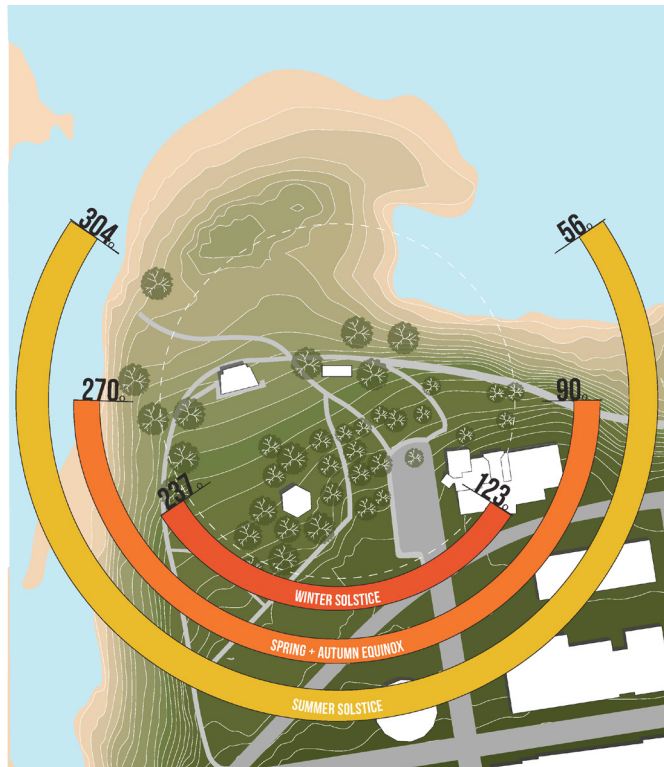

Figure 17: Site Solar

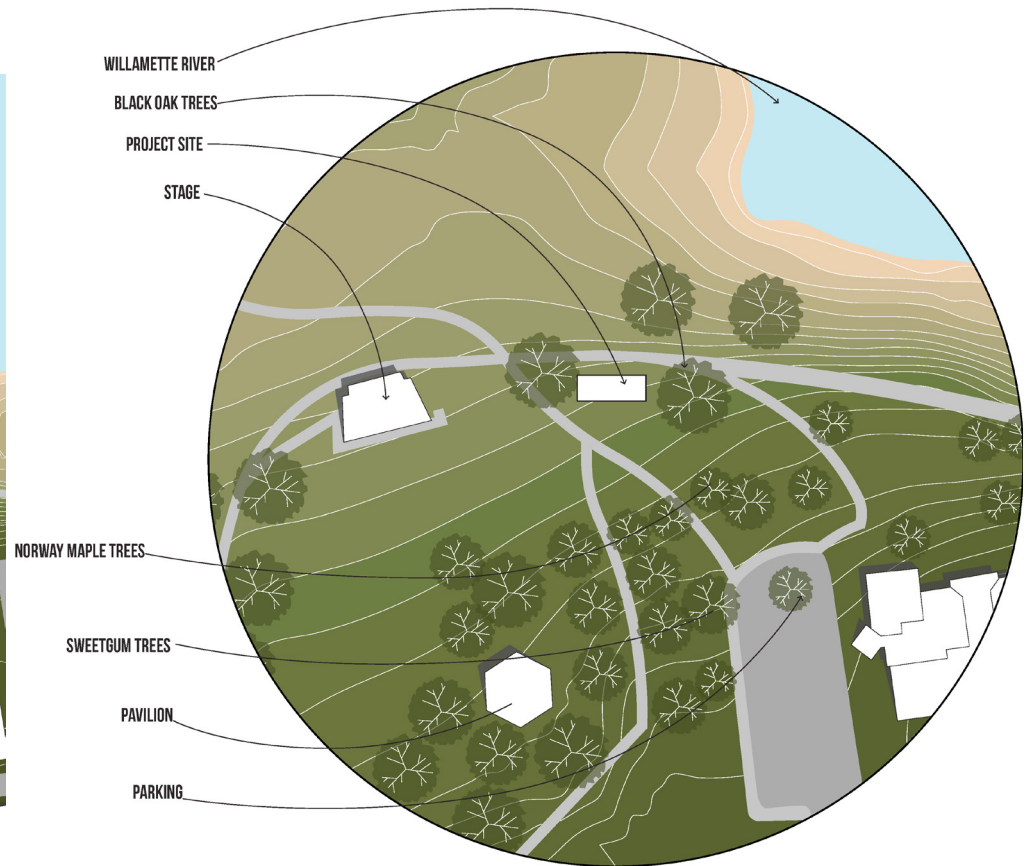

Figure 18: Site Plan

Site Selection

26

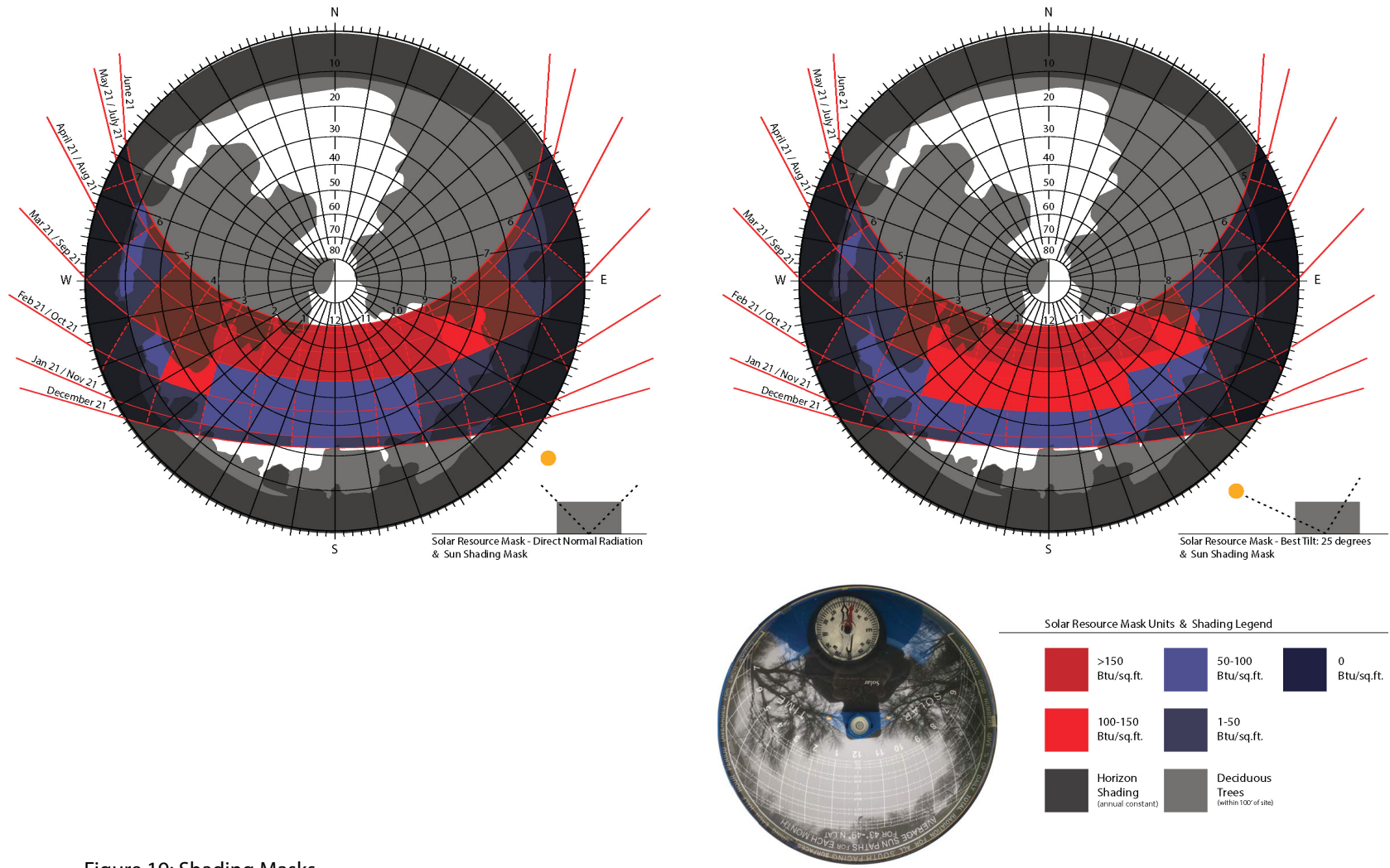

Figure 19: Shading Masks

Design

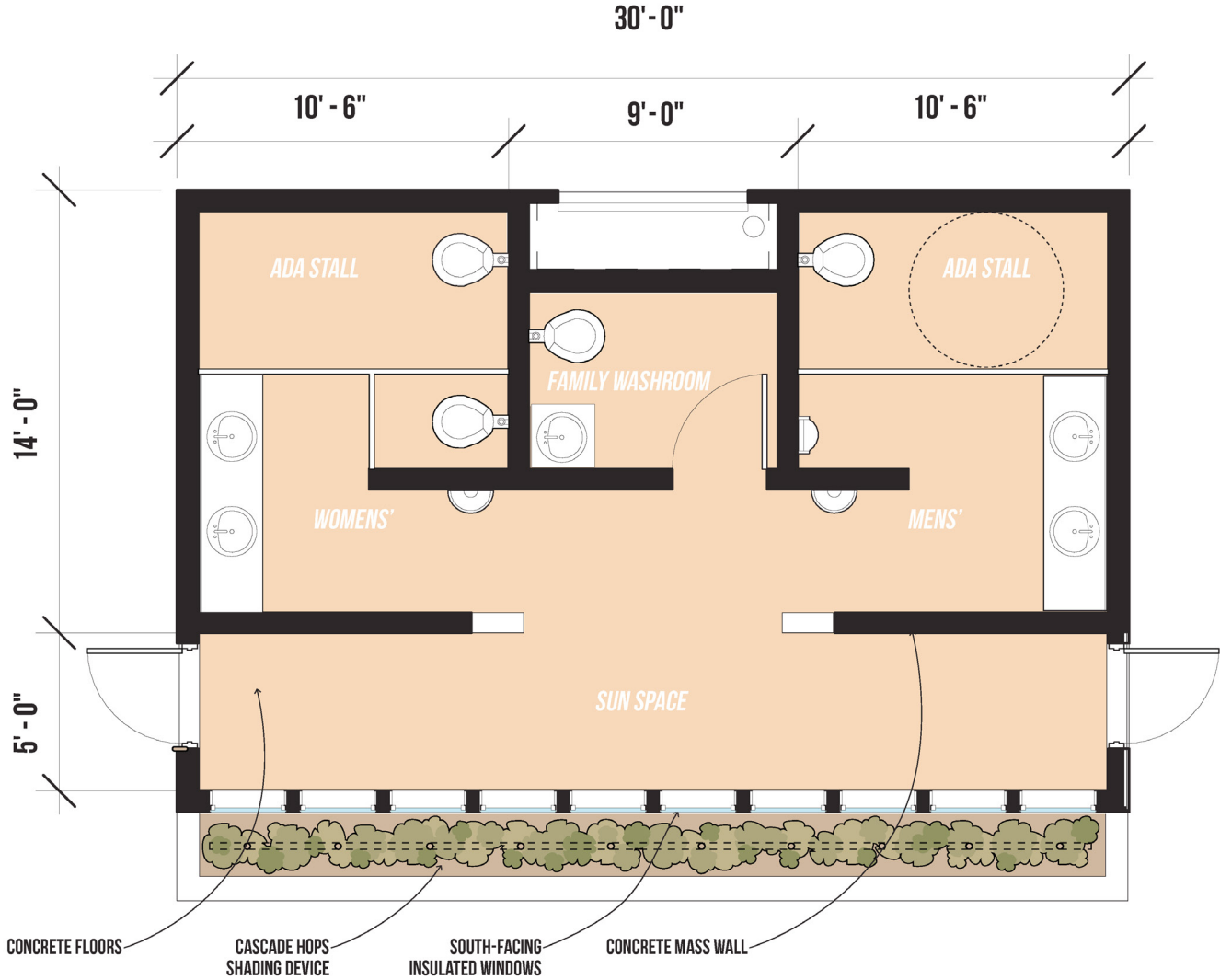

Figure 20: Bathroom Plan

Design

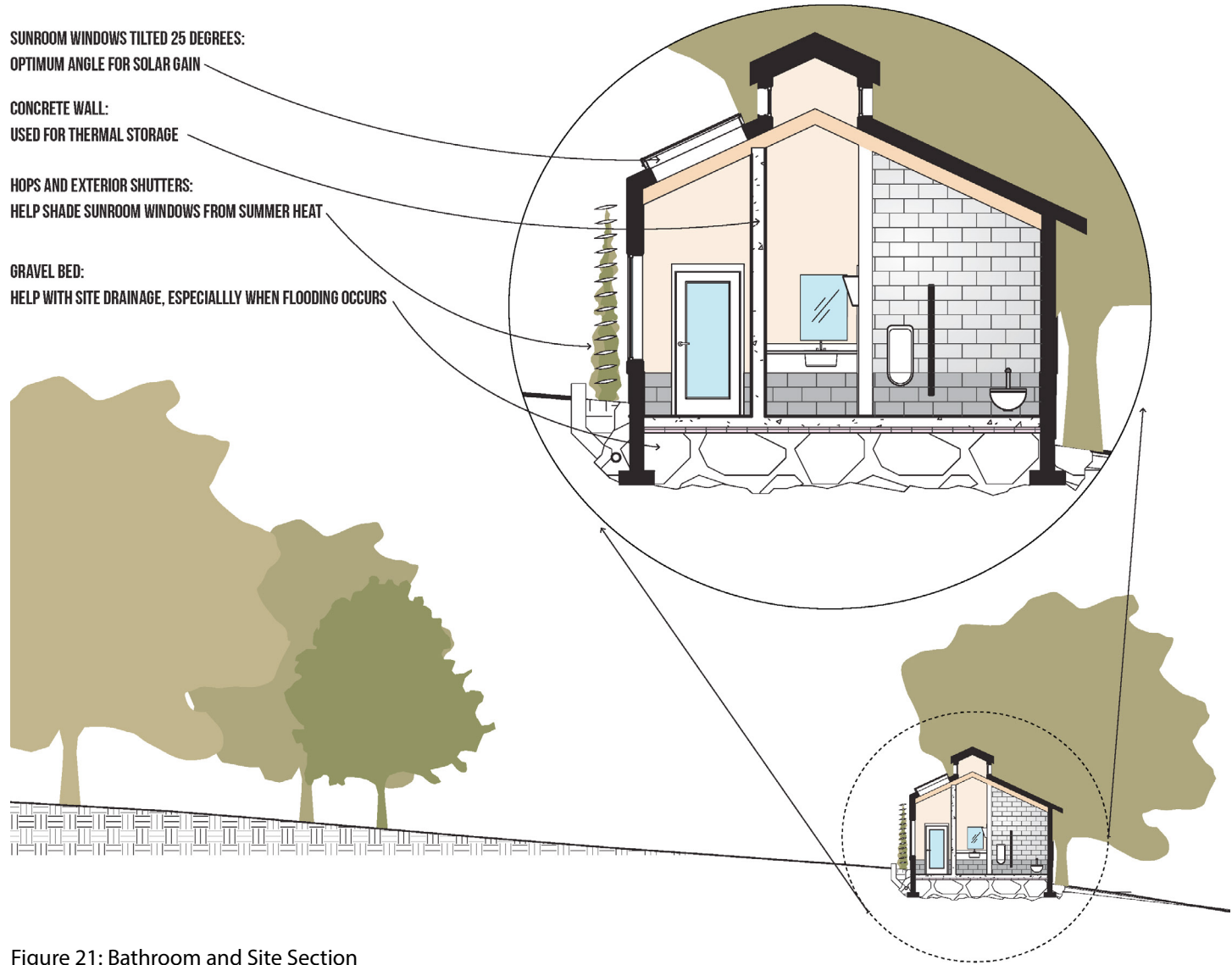

Figure 21: Bathroom and Site Section

Design

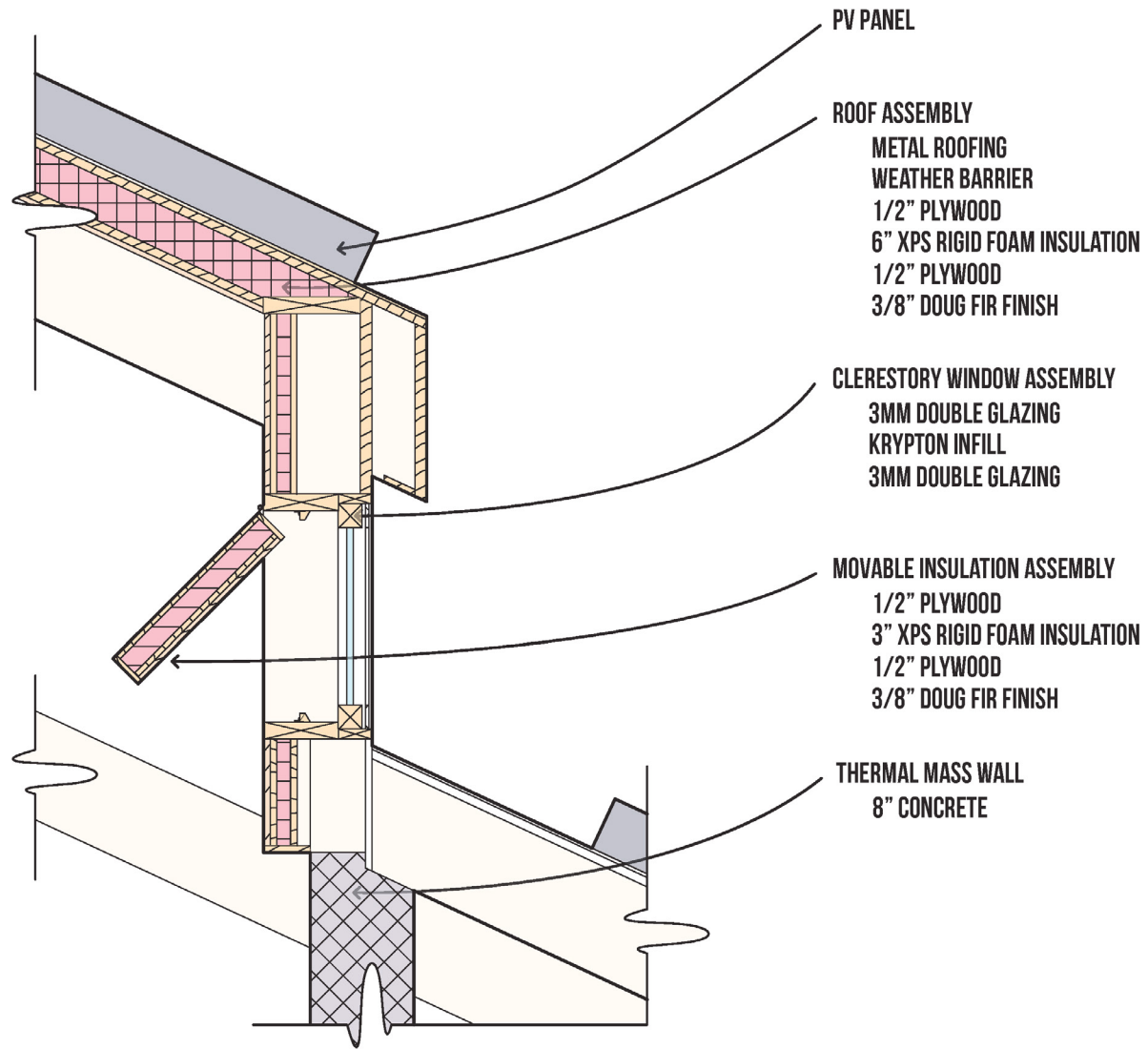

Figure 22: Movable Insulation Detail

Results

30

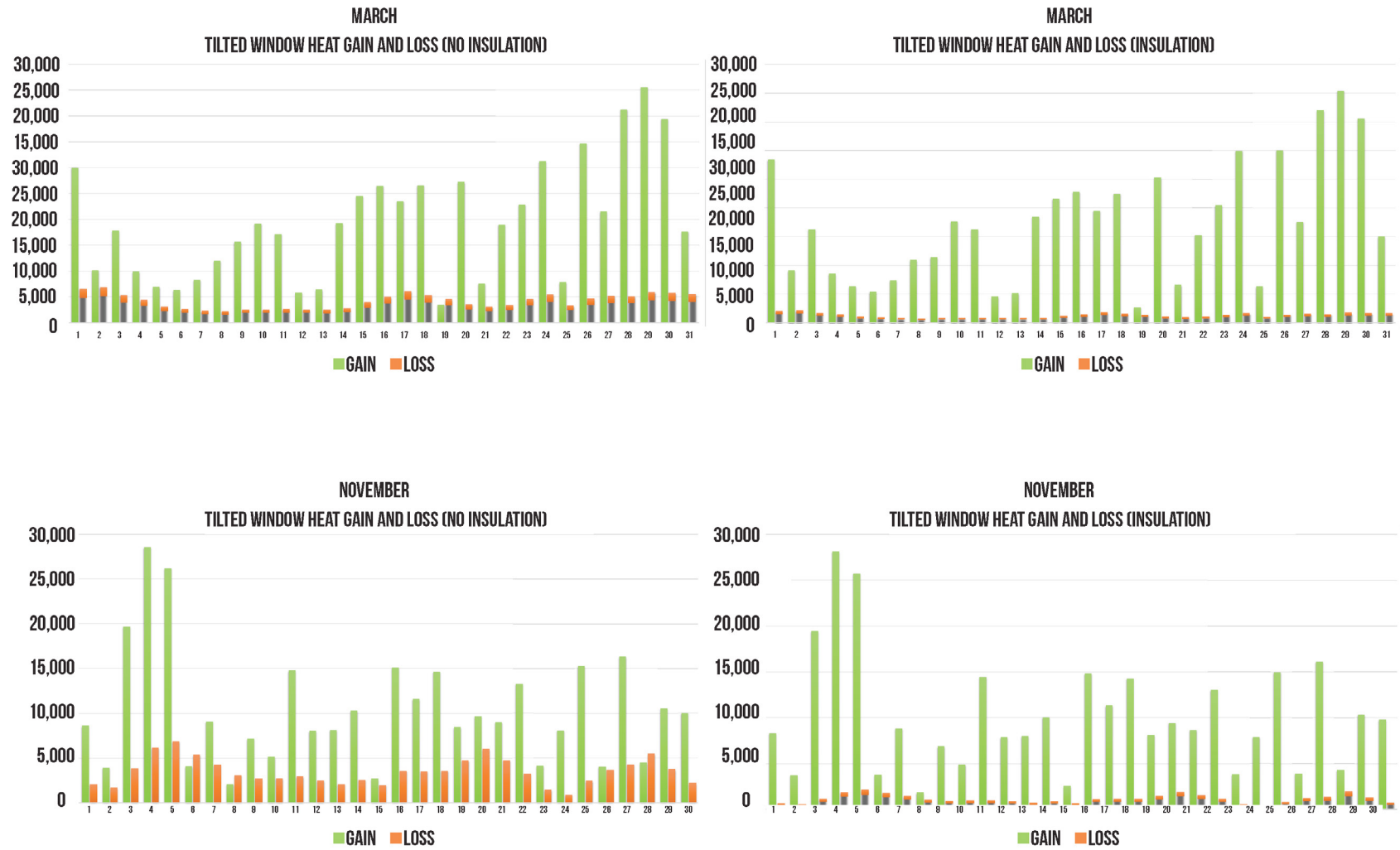

Figure 23: Heat Gain and Loss Graphs

Data

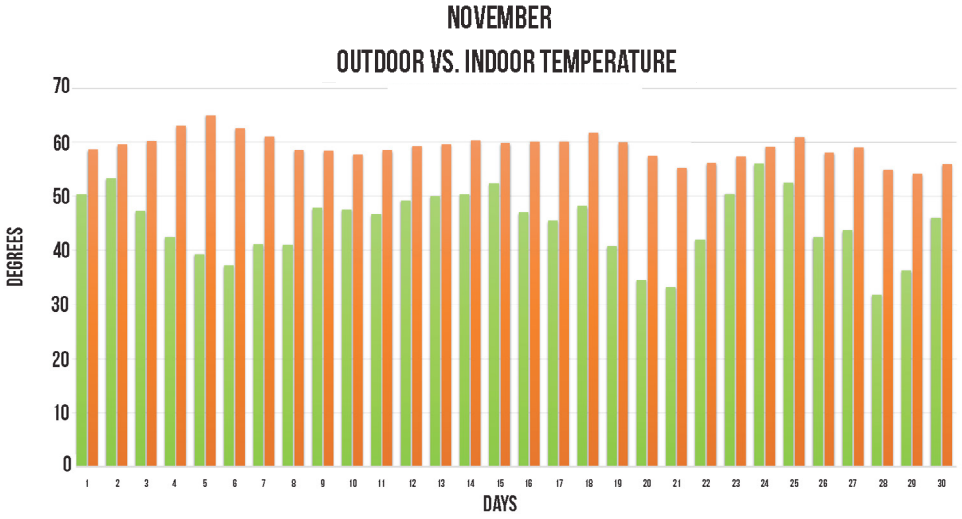
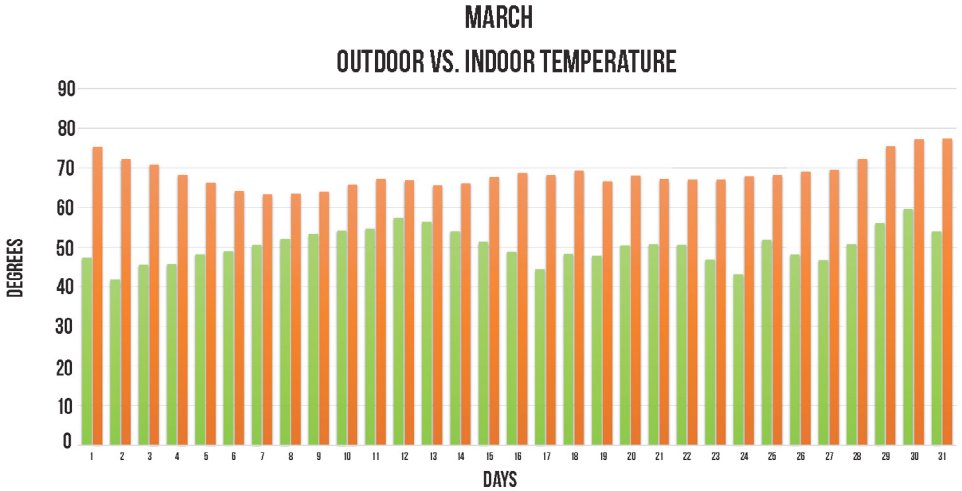

Figure 24: Indoor Drybulb Temp and Outdoor Drybulb Temp

■ OUTDOOR ■ INDOOR

Sunroom Designs

Otter's Furnace

Designers: Ana Misenas, Erik Barth, May Nguyen

Design Intentions

We plan to minimally impact the existing facility to create a passively heated space for residents to gather and relax in the colder months of the year. We envision this room to function as a 'solar furnace' to collect and emit heat in a semi-enclosed space.

One of the main inputs from the residents was that the gathering space was too cold throughout the year. Sedentary senior activities, like knitting, cause a low metabolic rate and little addition to space heating. We plan to combine thermal mass in the form of potted plants with direct and indirect solar gain in our 'solar furnace' to provide a warm haven for seniors.

Secondary goals of the new sunspace are to enhance views of the surrounding foliage and water and contribute to cooling the community room. Glazing should not only selectively let in sunlight, but should also promote views to the park beyond.

A final goal in the remodel is to enable operability of passive systems. We would like the inhabitants to be active participants in mediating their environment through manual controls. Movable insulation on pulleys will be pulled down at night to prevent heat loss and opened during the day to allow heat entry. Several awning windows in the sunspace can be opened or closed from the interior to control air exchange rates.

Site Selection

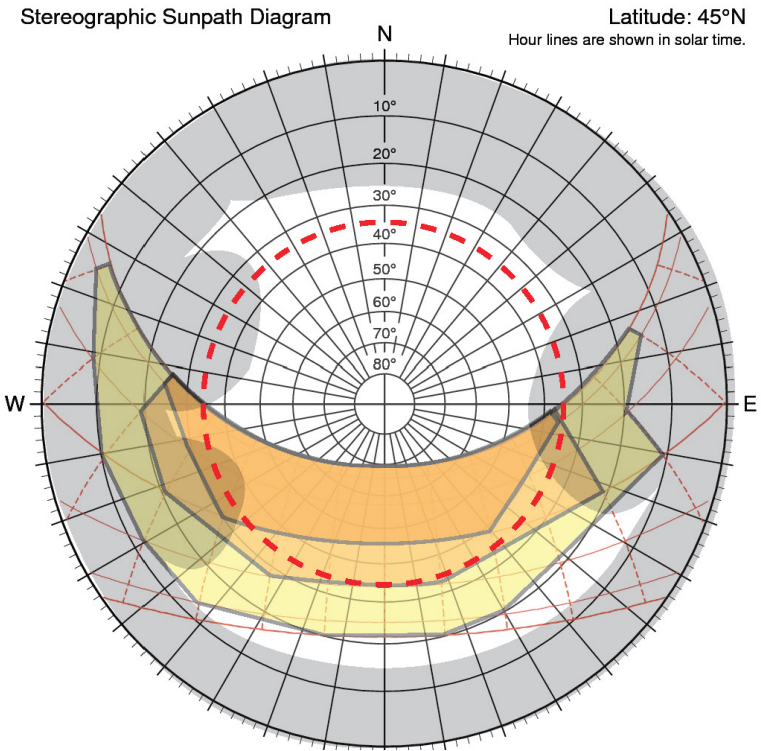
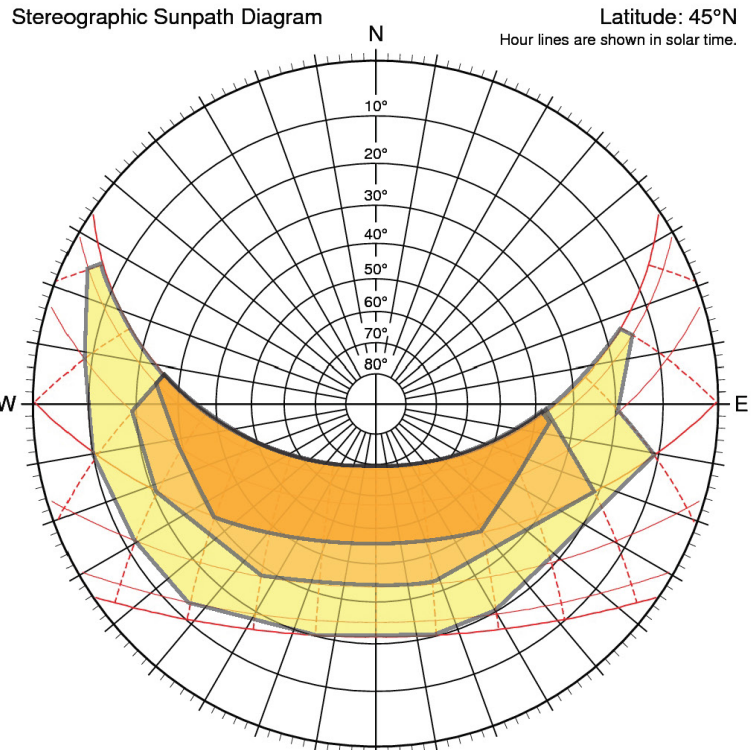
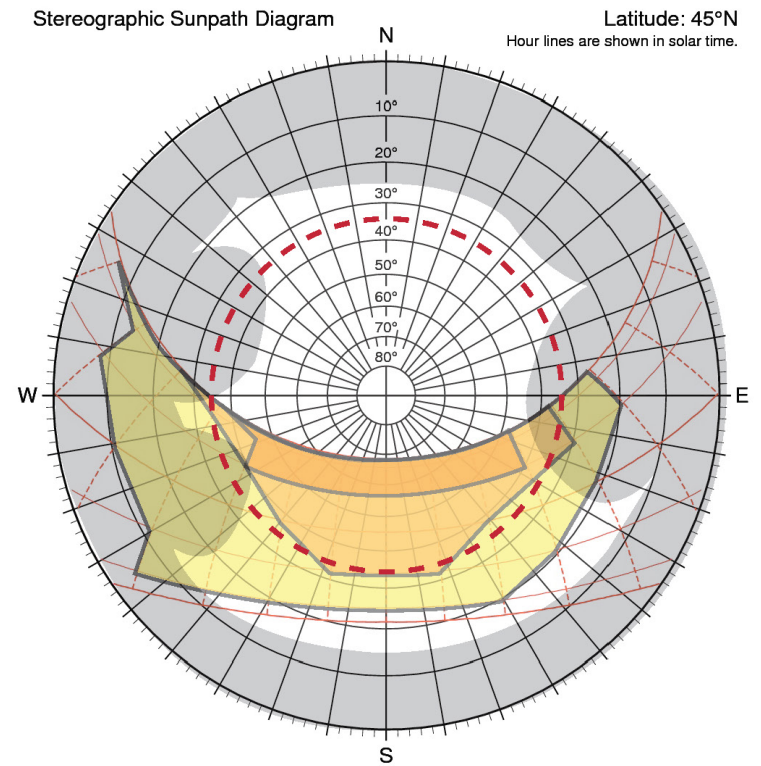
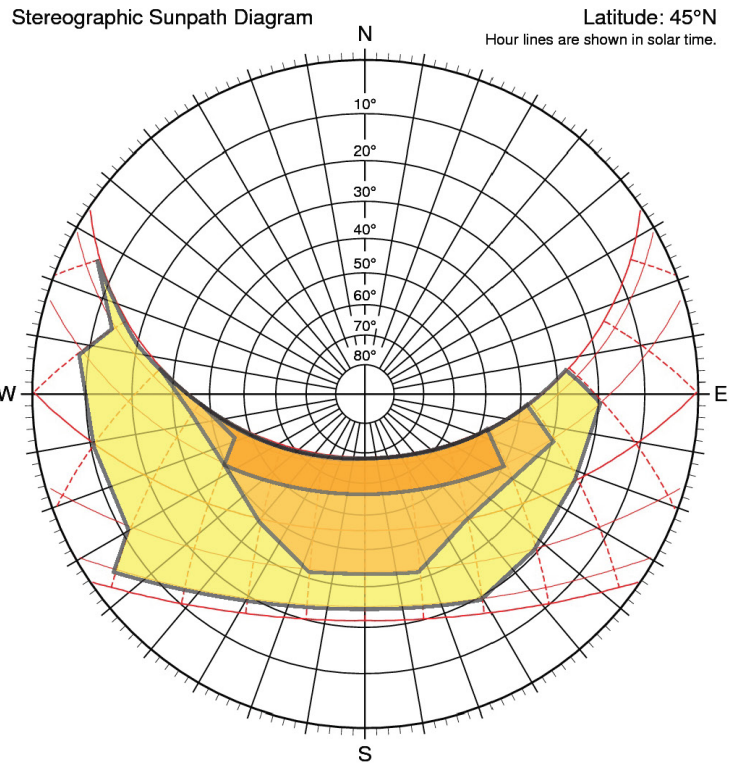

Figure 26: Solar Resource Shading Masks (July -

Site Selection



SUNROOM SECTION

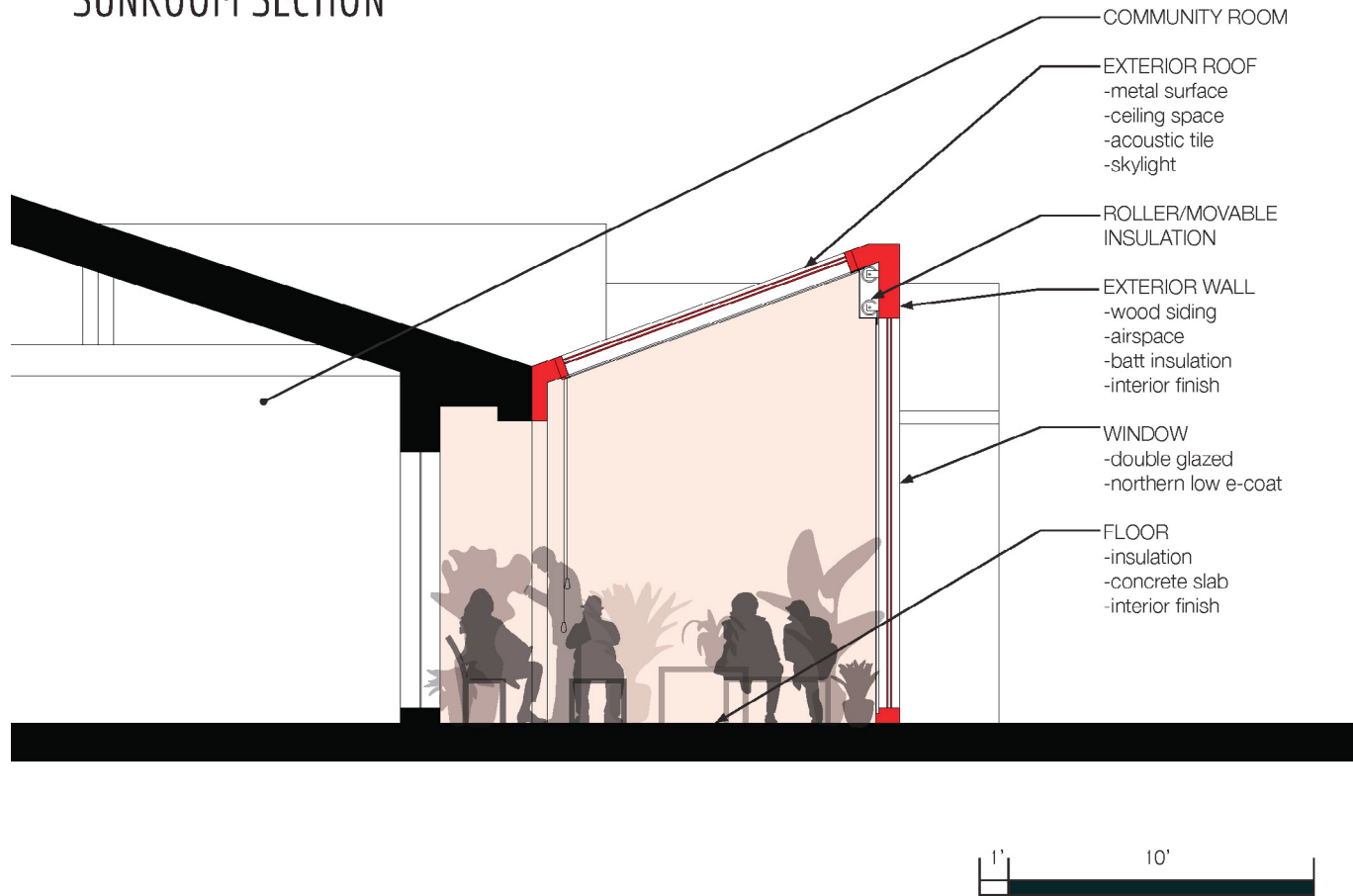
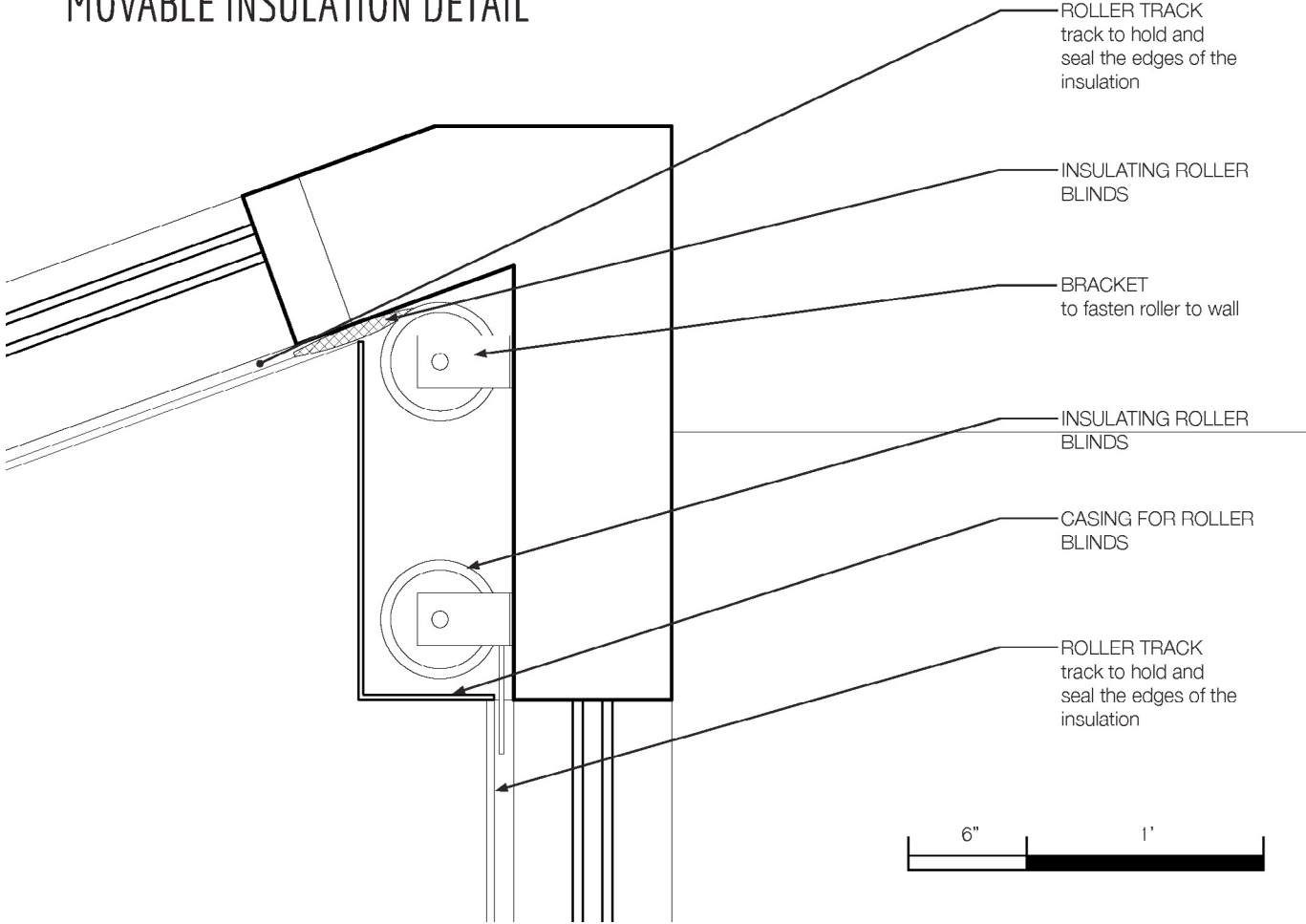

Figure 28: Section

MOVABLE INSULATION DETAIL



VERSION 1 : 30 DEGREE PITCH, LARGE SKYLIGHT

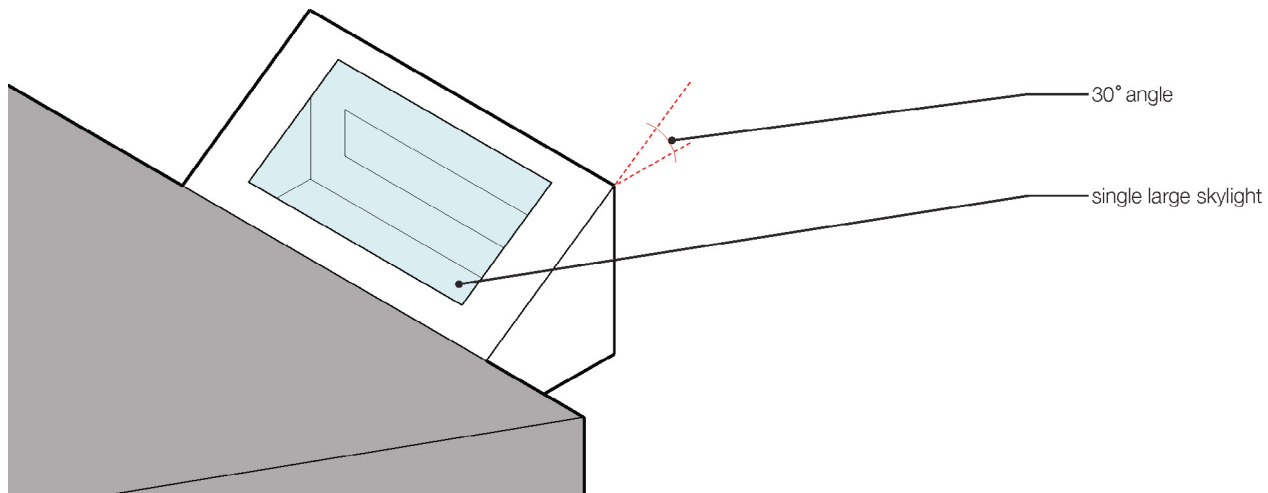
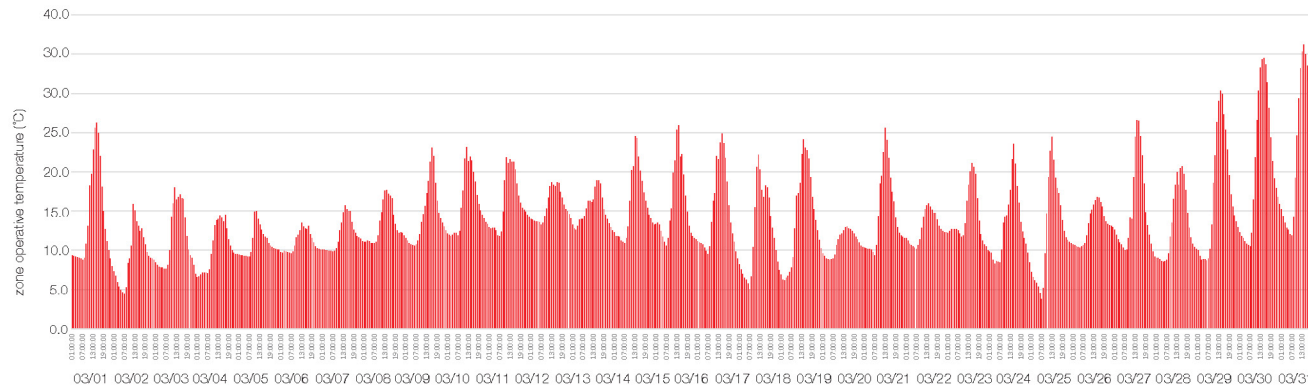

Figure 30: Version 1 - 30 Degree Pitch

VERSION 2 : 20 DEGREE PITCH, LARGE SKYLIGHT

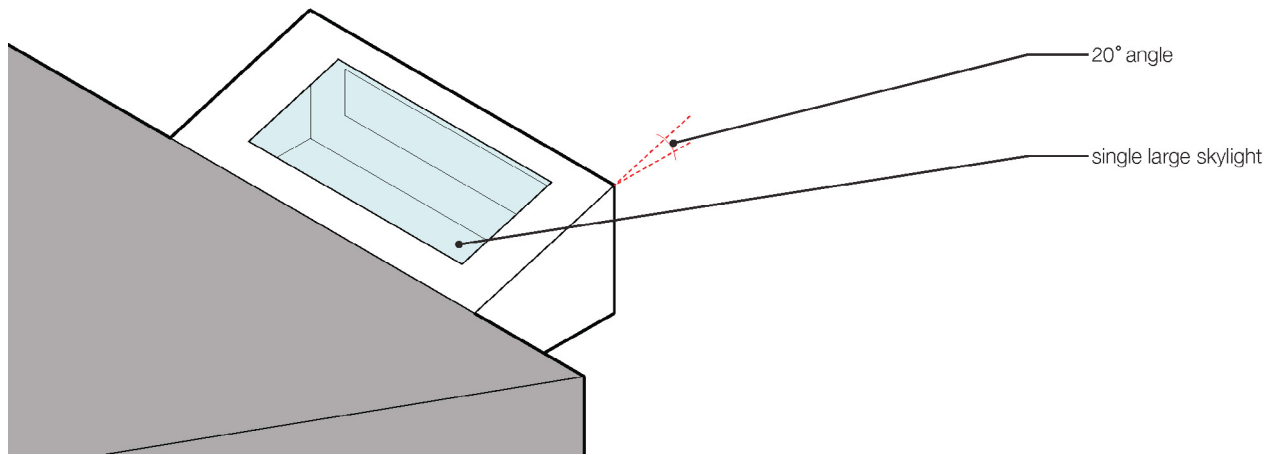
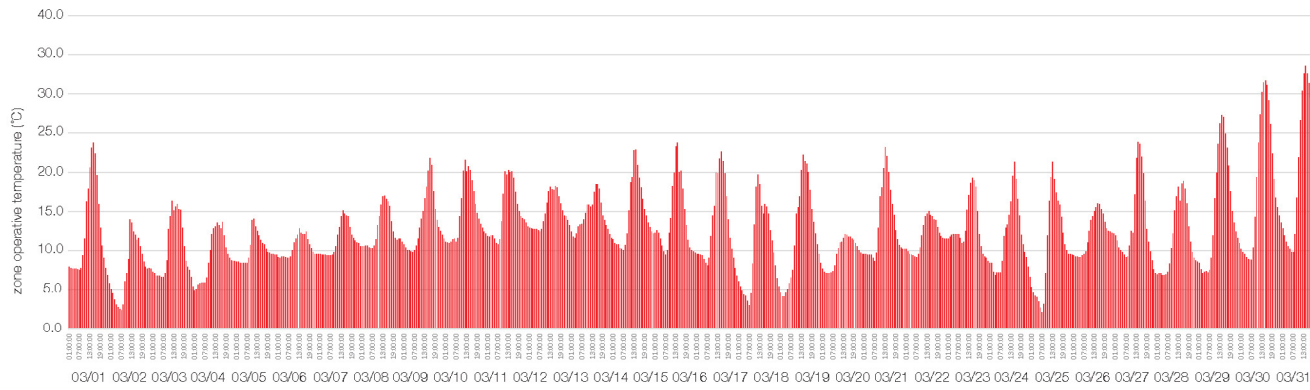

Figure 31: Version 2 -20 Degree Pitch

VERSION 3 : 20 DEGREE PITCH, SMALL SKYLIGHTS

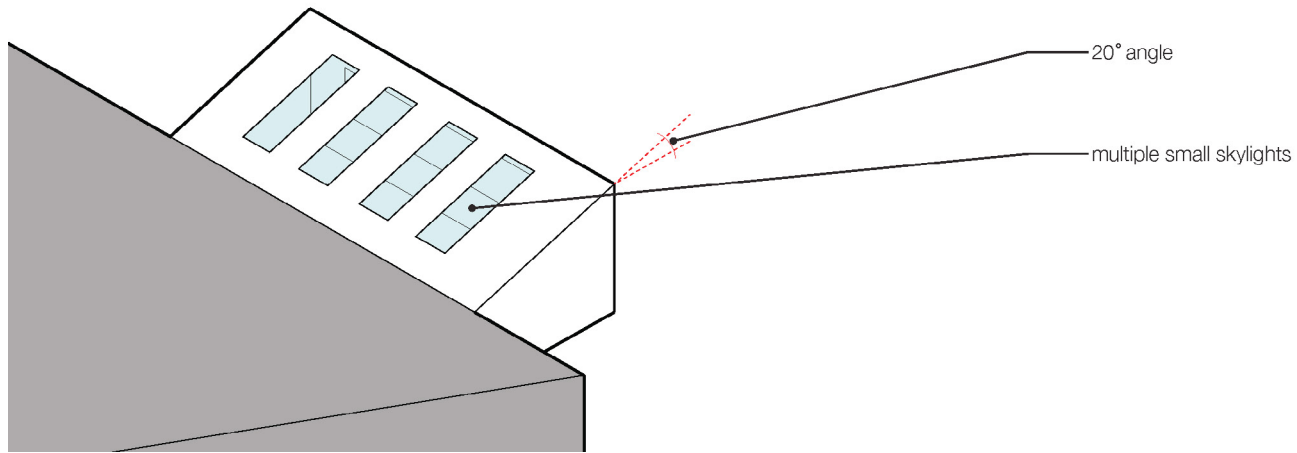
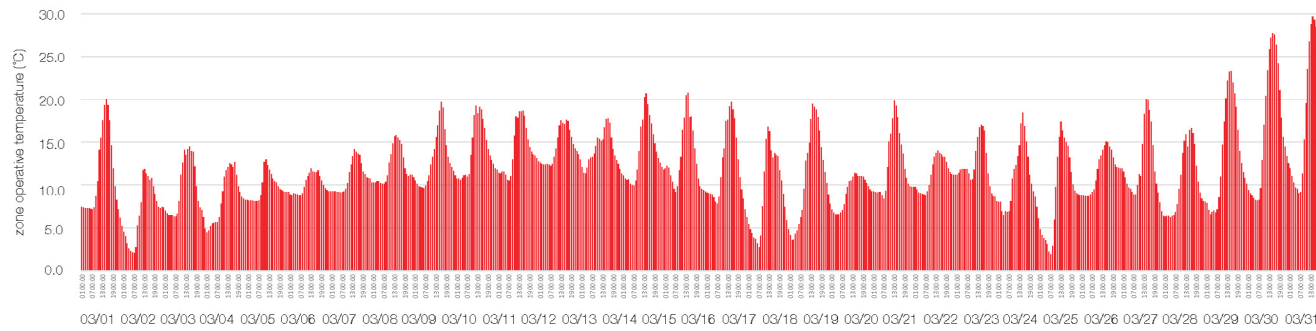

Figure 32: Version 1 - 20 Degree Pitch, Small Skylight

Data

SOLAR RESOURCE CORVALLIS, OREGON

40

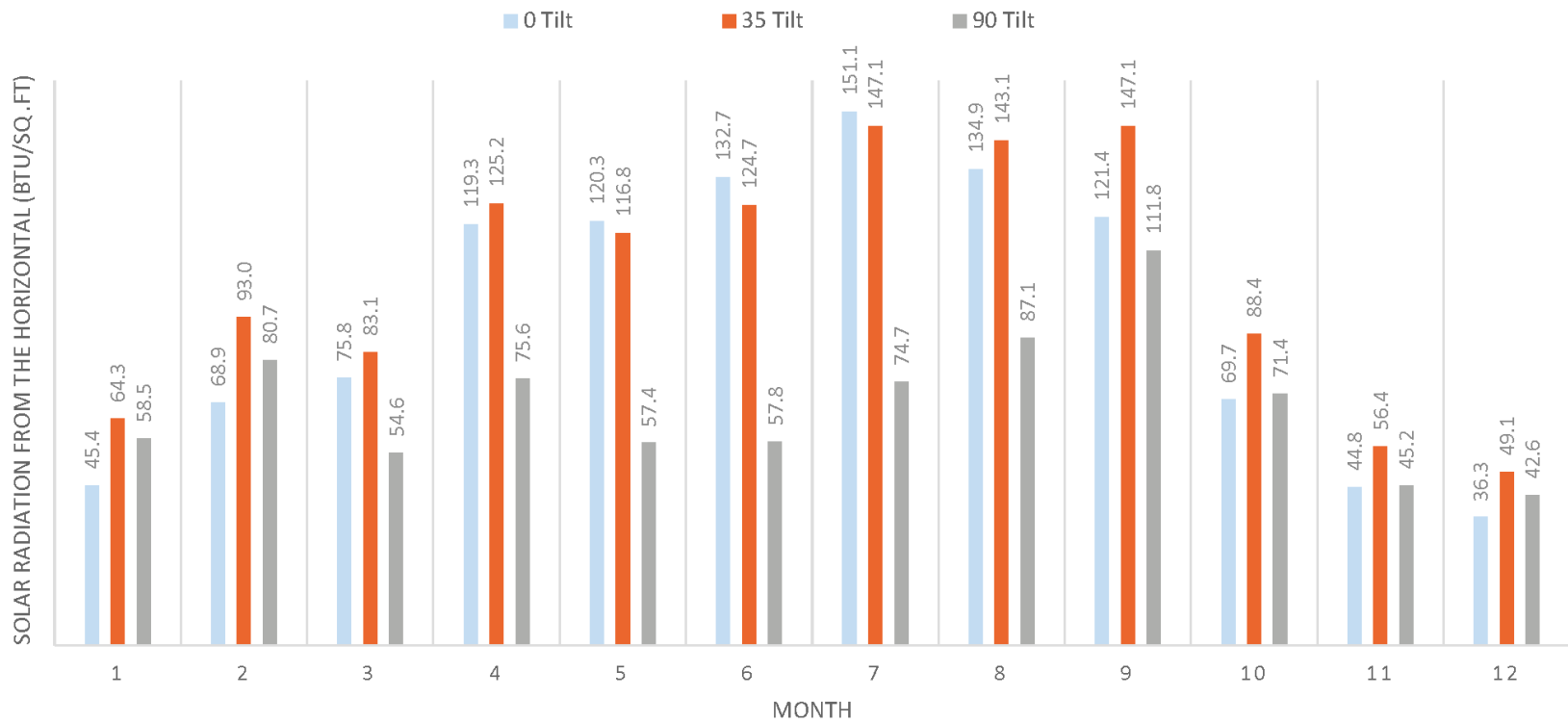

Figure 33: Solar Resource Graph

SOLAR RADIATION CORVALLIS, OREGON

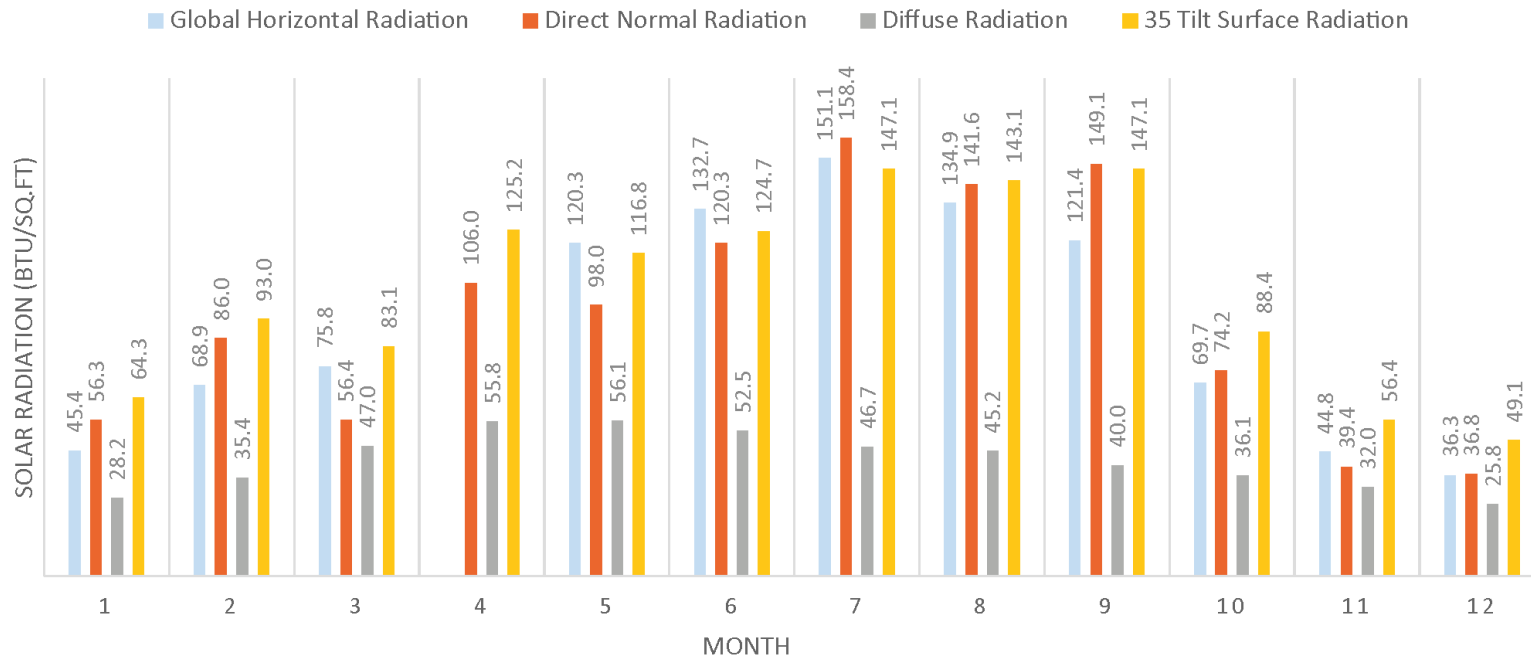
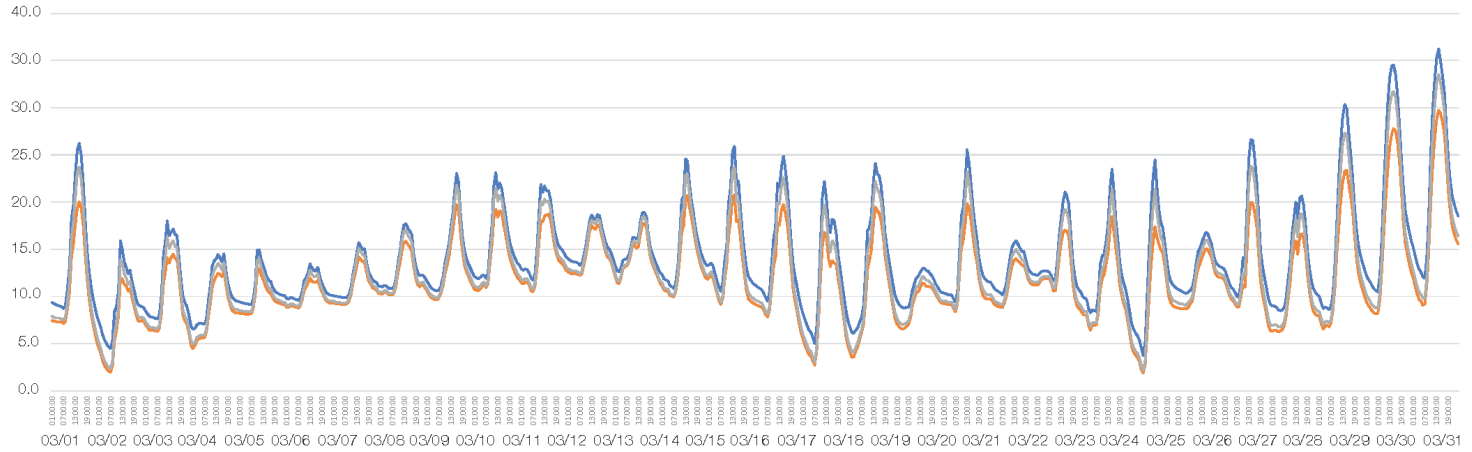

Figure 34: Solar Raddiation

Results

COMPARATIVE ANALYSIS



■ 30 Degree Pitch, Large Skylight
 ■ 20 Degree Pitch, Large Skylight
 ■ 20 Degree Pitch, Small Skylights

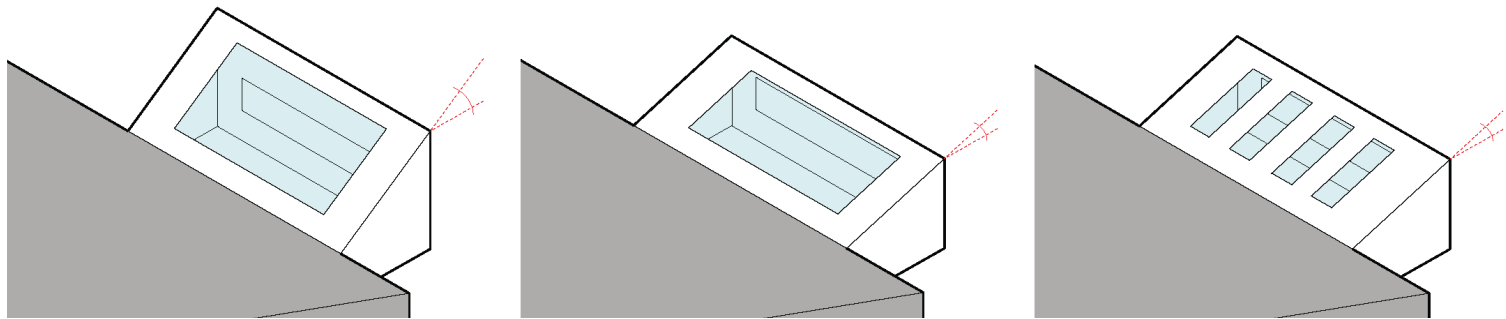

Figure 35: Comparative Analysis Graph

Community Sunroom

Designers: Chazandra Kern, Dristi Manandhar, Isabel Rivera, Zhengxian Jin

Design Intention

The project's design proposes to be context appropriate, by recognizing the existing context scales. (i.e. landscape scale through the river, trees and landform, pedestrian scale of community users as well as park users, and existing building scale).

By acknowledging a connection between the existing building and its landscape the project becomes an integrating space of the old and the new community space through views and spatial articulation.

The design integrates affordability strategies through construction design solutions, easy to build and install as well as the selection of local materiality. By incorporating a detach solution to the existing building, minimizes the cost of intervention and easier installation process.

The spatial flexibility, which can allocate different uses or multiple community activities, is proposed at the interior of the sunroom space as well as outside terrace deck area. The use of movable walls and window that can open to the outside will provide the space flexibility.

Activities in the sunroom space will invite tabletop games, catering parties (lunch/dinners), book club, arts and crafts, and gardening activities at the exterior deck area. We expect activities to have a maximum capacity of 20 people.

The sunspace design is intended to feel like a warm space during cold seasons that harvest daylighting availability throughout the space by not compromising visual and thermal comfort. During summer month, strategies to provide shadows and minimize overheating would allow creating a fresh and pleasant space to be in.

Site Selection



Figure 37: Site Plan

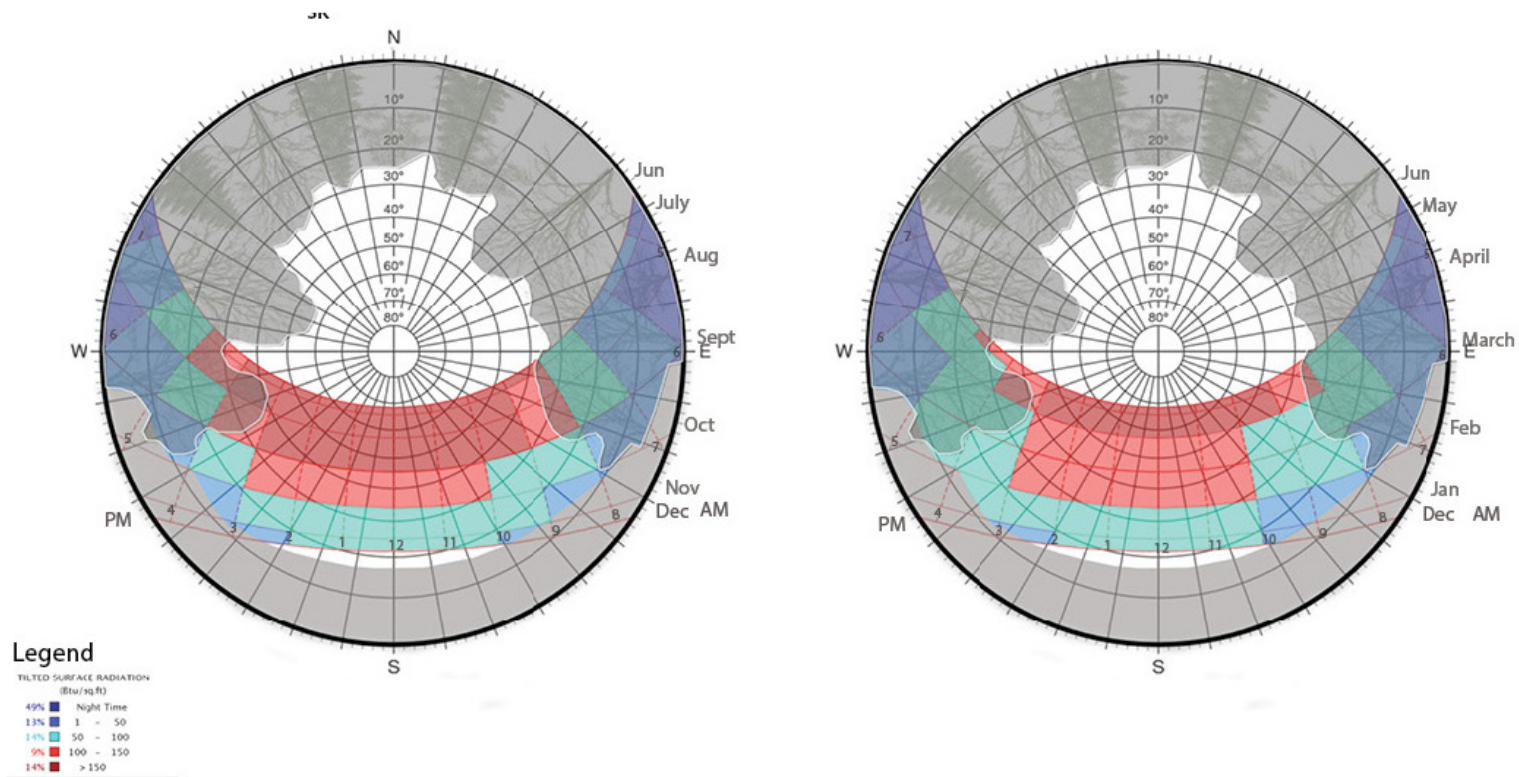
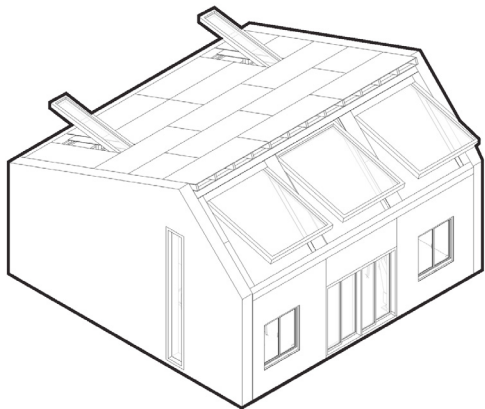

Figure 38: Solar Resource

The Solar Site Resource Mask shows the shadow casted onto our proposed buildable area by the [existing building](#) and [trees](#) on the site, shown by the gray hatching. The overlay of color shows the potential of heat gain on a tilt of [45 degrees](#).

Design



Option 1

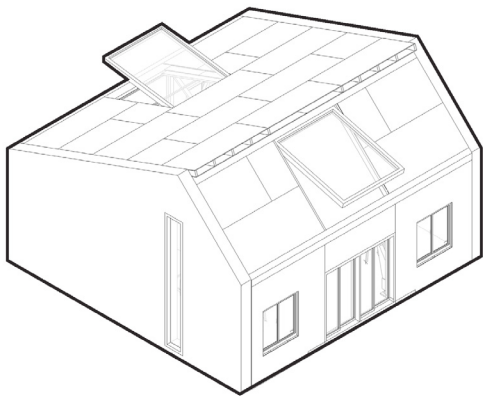

Option 2

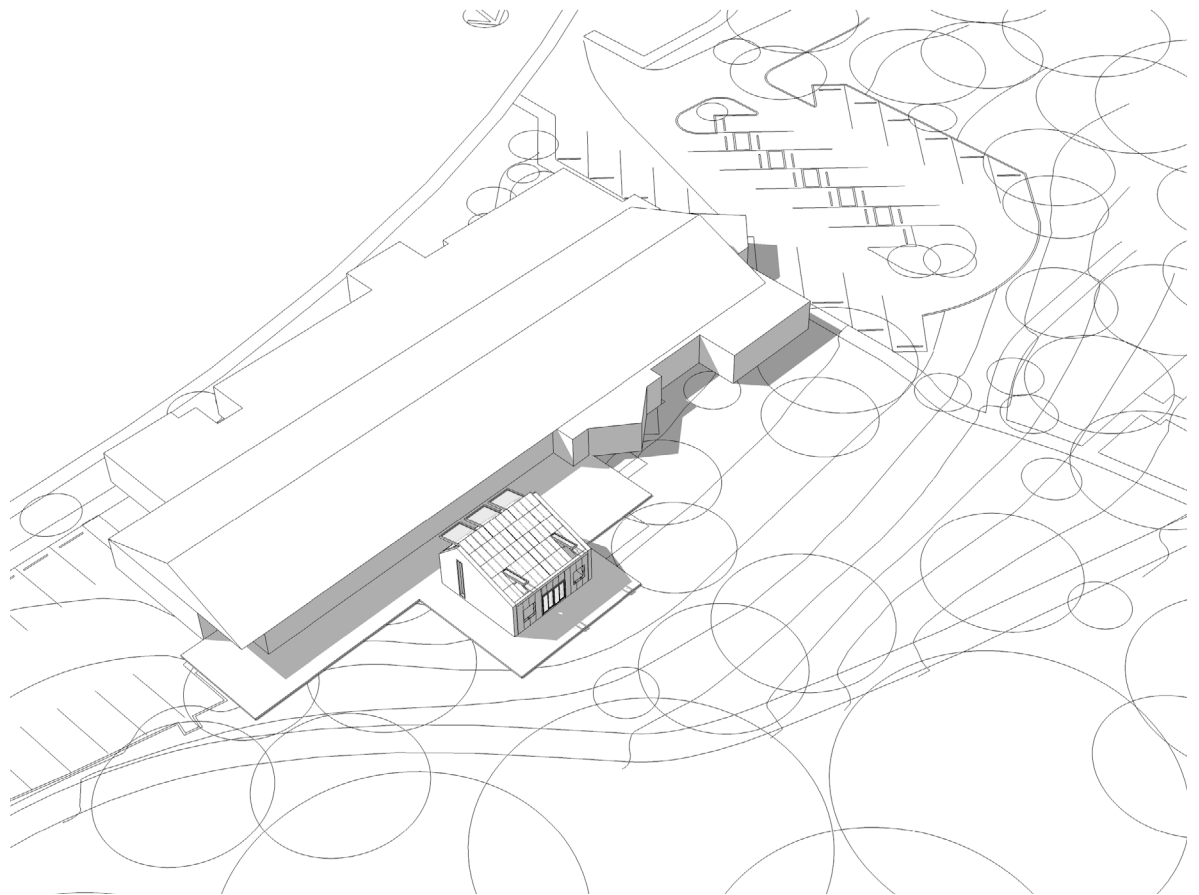

Figure 40: Site Axonometric Drawing

Figure 39: Design Options

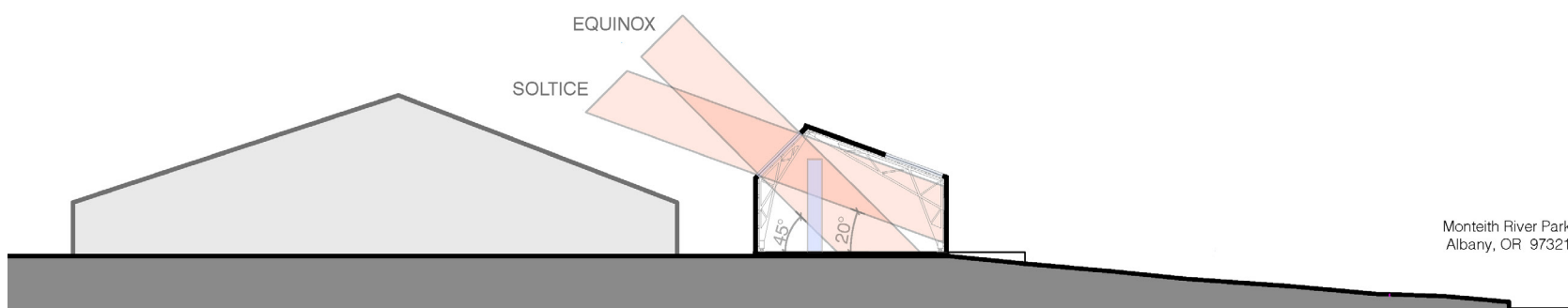
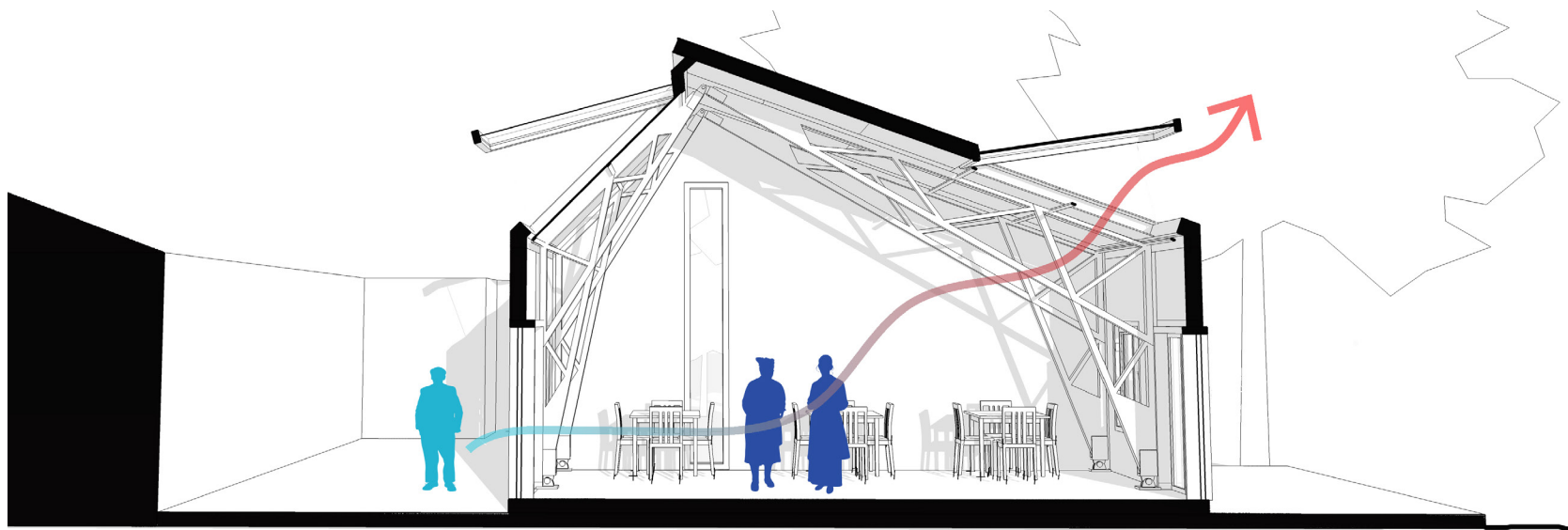
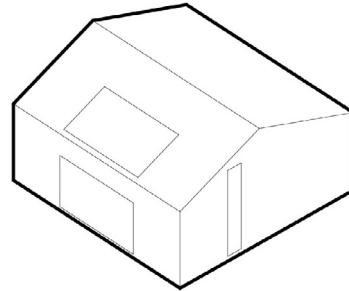
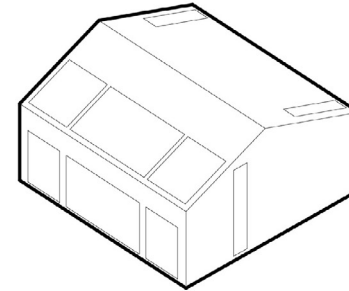

Figure 41:

Results



January /June
Option 1



January /June
Option 2

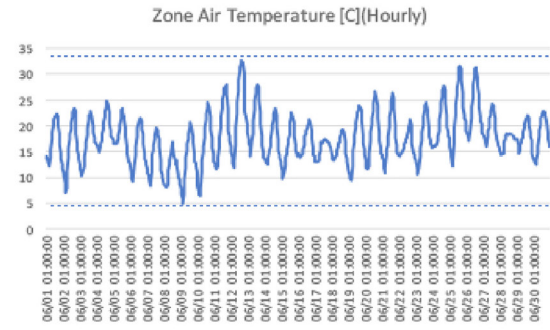
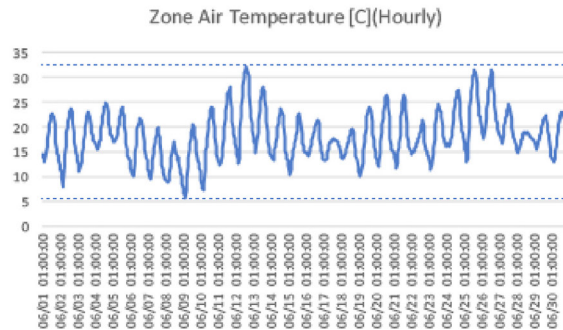
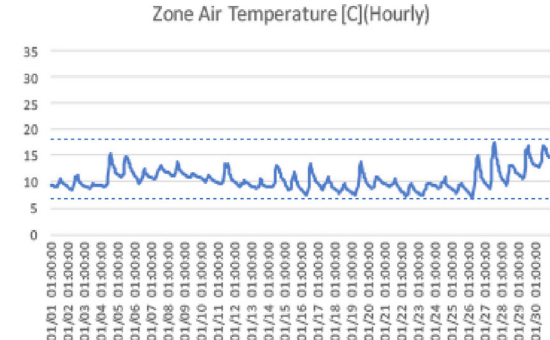
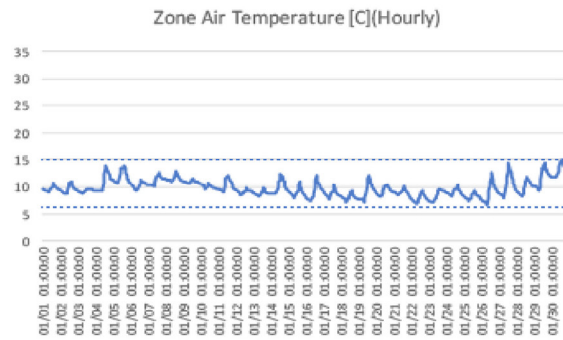
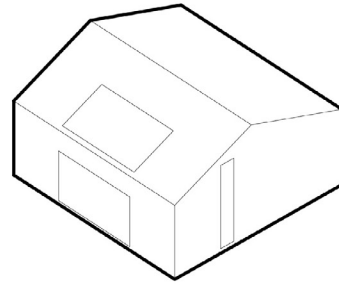
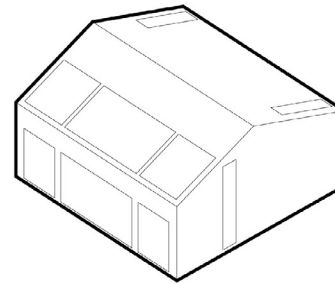

Figure 42: Air Temp Change

Results



March
Option 1



March
Option 2

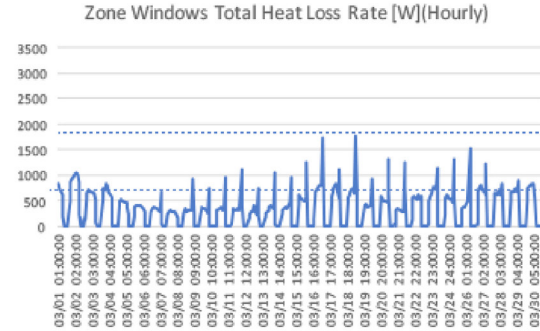
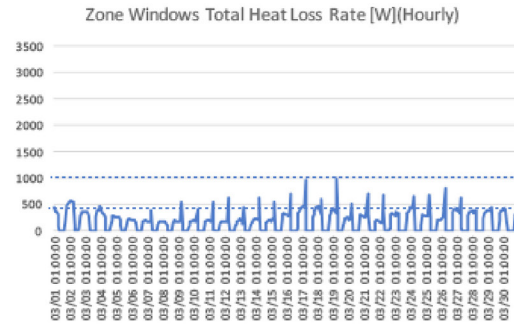
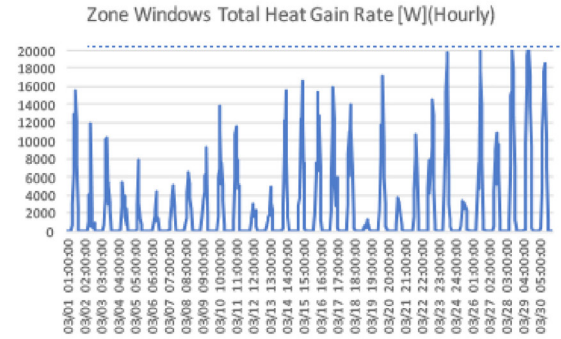
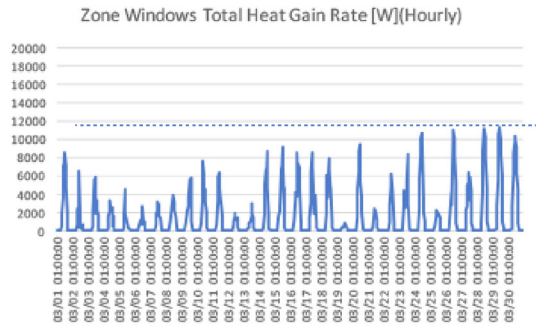

Figure 43: Heat Gain and Loss

Pollinator Protection

Designers: Jacqueline Greazzo, Alshley Kopetzky, Danielle Pomeroy, Kayla Zander

Design Intention

Expanding Albany's relationship to nature while preserving the natural landscape is a worthwhile project.

We see this design opportunity as a way to inform the community on passive thermal technology. Its practical implementation makes it a valuable option for sustained horticulture in relationship to its surrounding context. Thermal comfort throughout the seasons is an important aspect of the project in terms of providing consistent growth of native plants yearround. We see thermal comfort as a response to balancing control and choice. It is our intent to create a naturally controlled ecosystem that responds to Albany's communal needs.

The greenhouse will be located near the newly proposed visitors center to create a localized hub for community members to engage and connect. Through detailed site analysis we are prepared to take on designing passive greenhouse that find an equilibrium between people and place.

Not only is local engagement a value for what we see in Albany, but also the education of pollination and providing plants species that support these needs holistically. Working with the City of Albany, we are seeking to create a greenhouse that can help grow these networks as well as valuable ecological efforts.

Site

Selection



Figure 44: Proposed

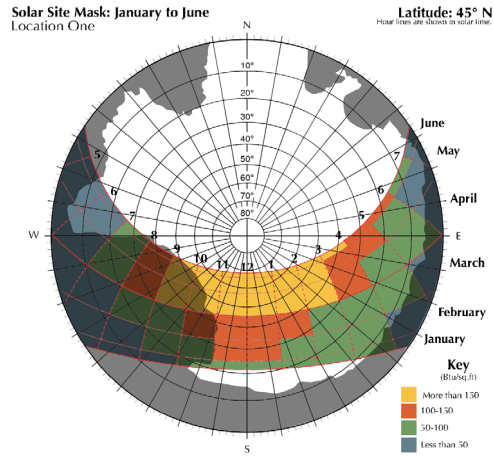

Figure 45: Site Section

The location of the greenhouse is not only optimal for passive heating techniques, but also bridges the space between Thornton Lake and the visitor's center.

Data

Test Location 1



Test Location 2

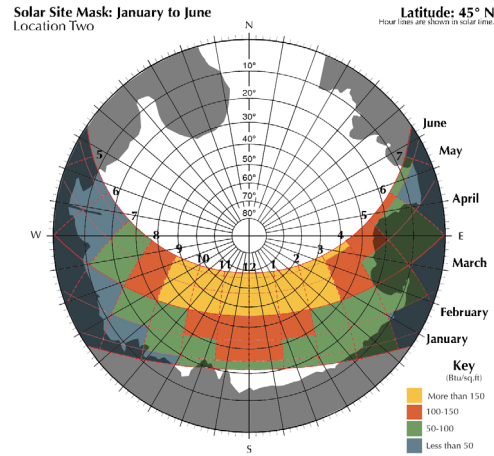

Greenhouse Location

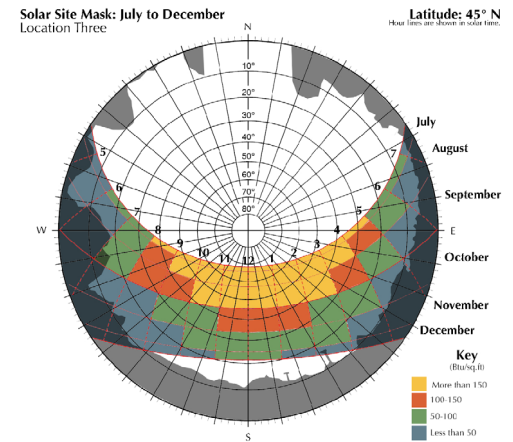
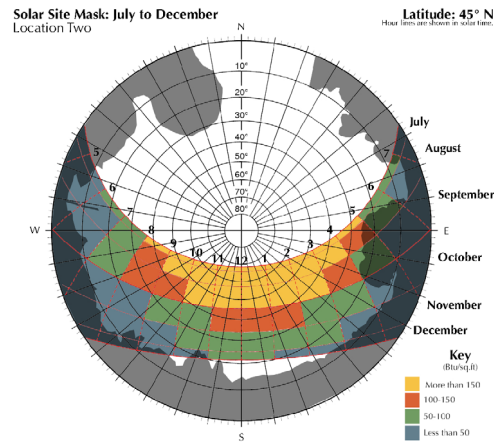
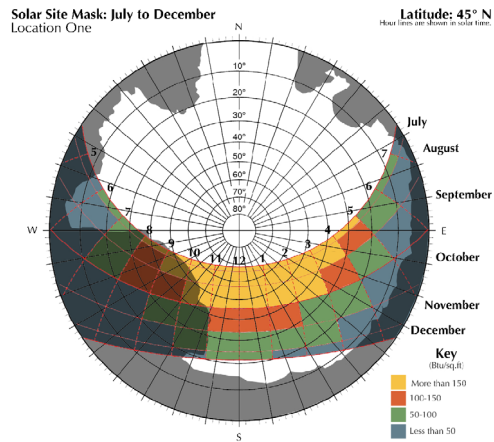
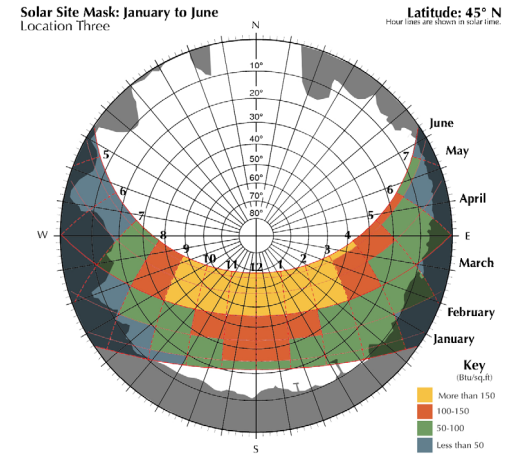
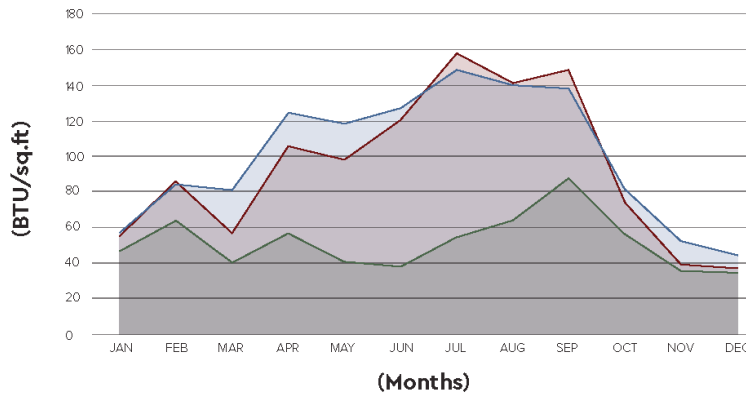

Figure 46: Solar Site

Optimal Roof Tilt 23 degrees



OPTIMAL TILT KEY

- Optimal Tilt Angle (23 degrees) (BTU/sq.ft)
- Direct Normal Radiation Average Daily (BTU/sq.ft)
- Vertical Tilt Angle (90 degrees) (BTU/sq.ft)

Net Solar Resource

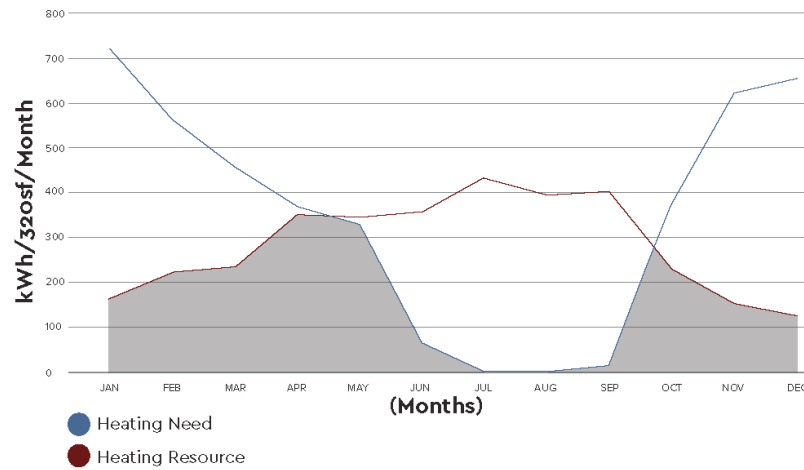

Heating Degree Days

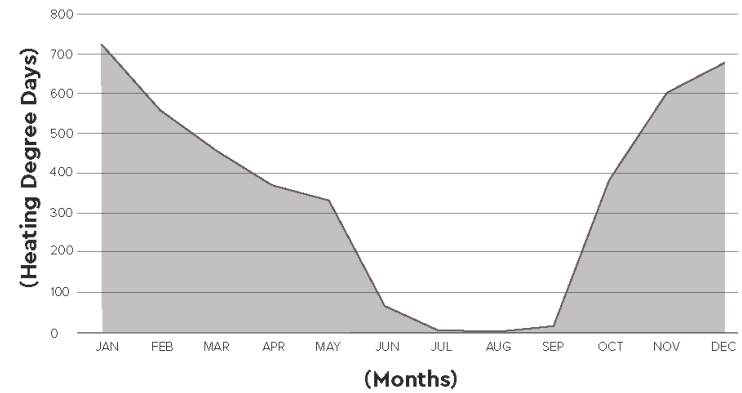

Figure 47: Optimal Tilt and Heating

Heating need was based on kWh/320sf/Month (320sf is the size of the south roof glazing)

Design



Wood Cladding

Douglas Fir

- Resistant to rot
- Locally sourced
- Durability and long life span of unfinished material

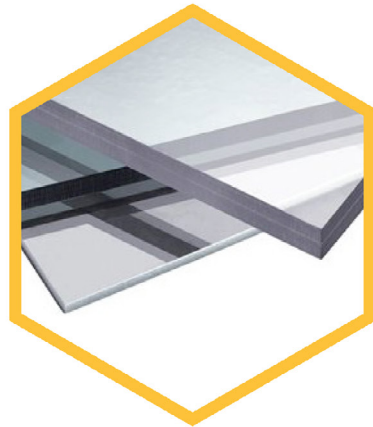

Glazing

Polycarbonate Sheet

- Non-toxic material
- Substitution for ordinary glass
- High light transmittance
- High level of thermal control

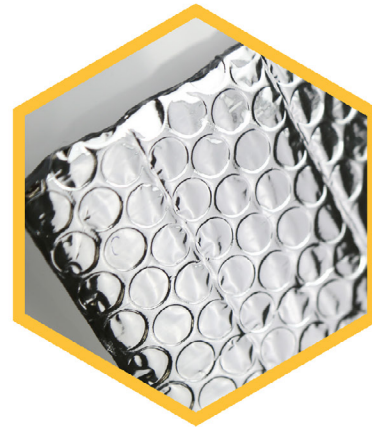

Movable Insulation

Bubble Foil Insulation

- Daylight control
- High energy saving
- High light emission control
- Excellent thermal barrier

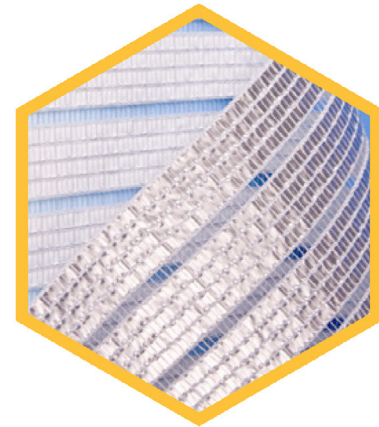

Movable Shading

Ludvig Svensson Solaro

- Daylight control
- Low energy savings
- Low light emission control

Figure 48: Greenhouse

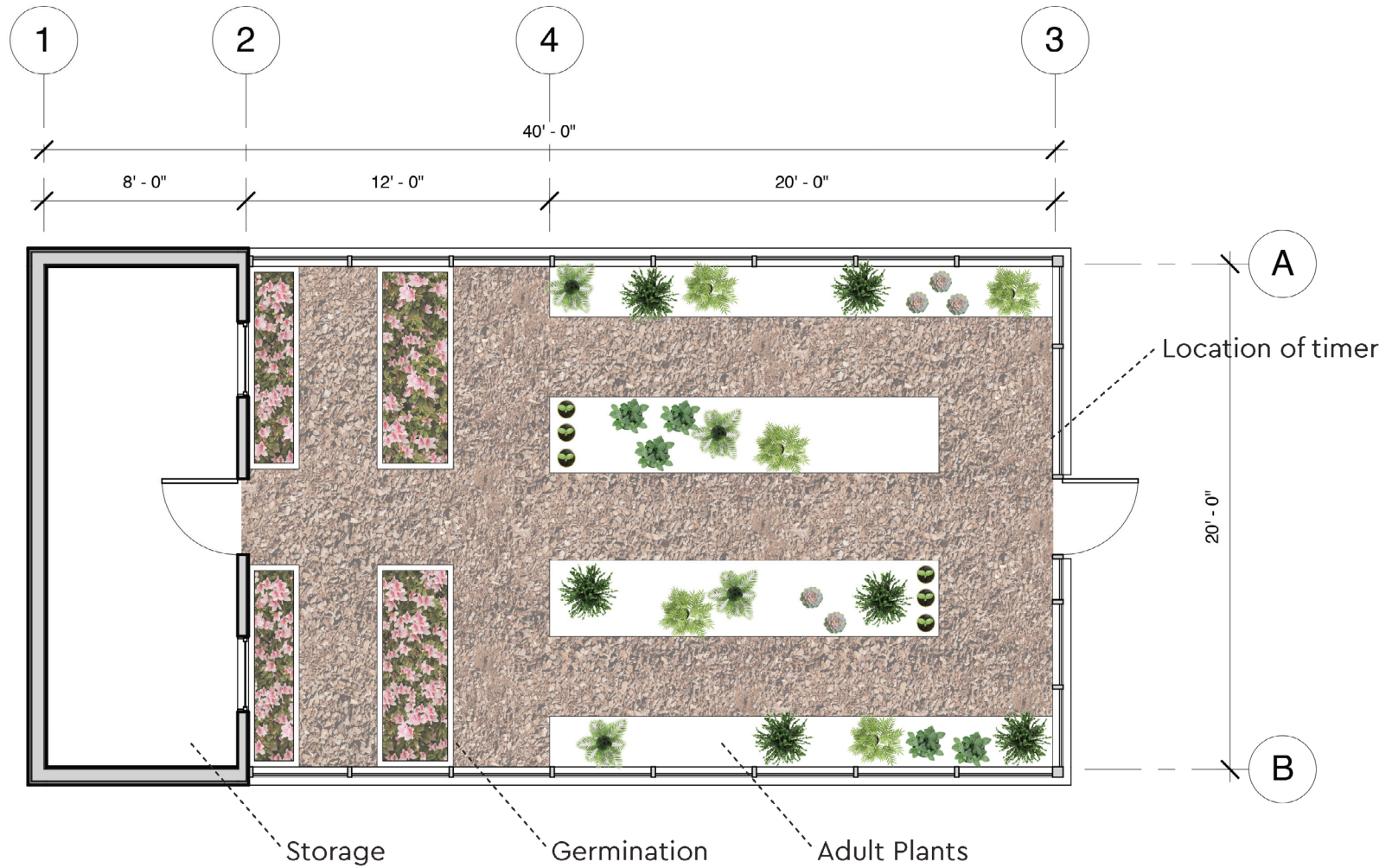

Figure 49: Greenhouse Plan



Figure 50: Greenhouse

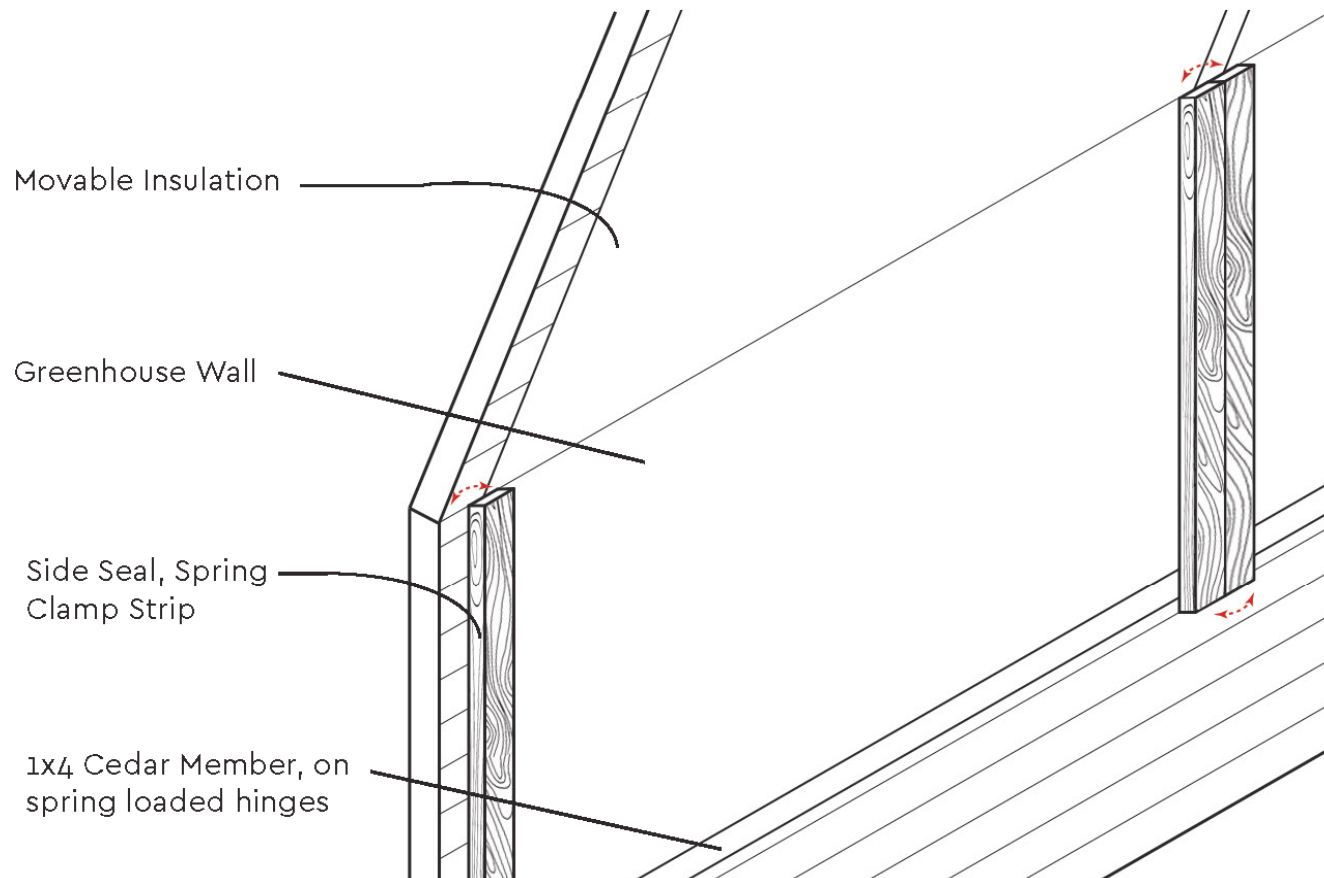

Figure 51: Edge Seal Detail

Wood members are attached to the mullions of the greenhouse, and are able to swing on a spring-loaded hinge to open and close.



Figure 52: Greenhouse

Data

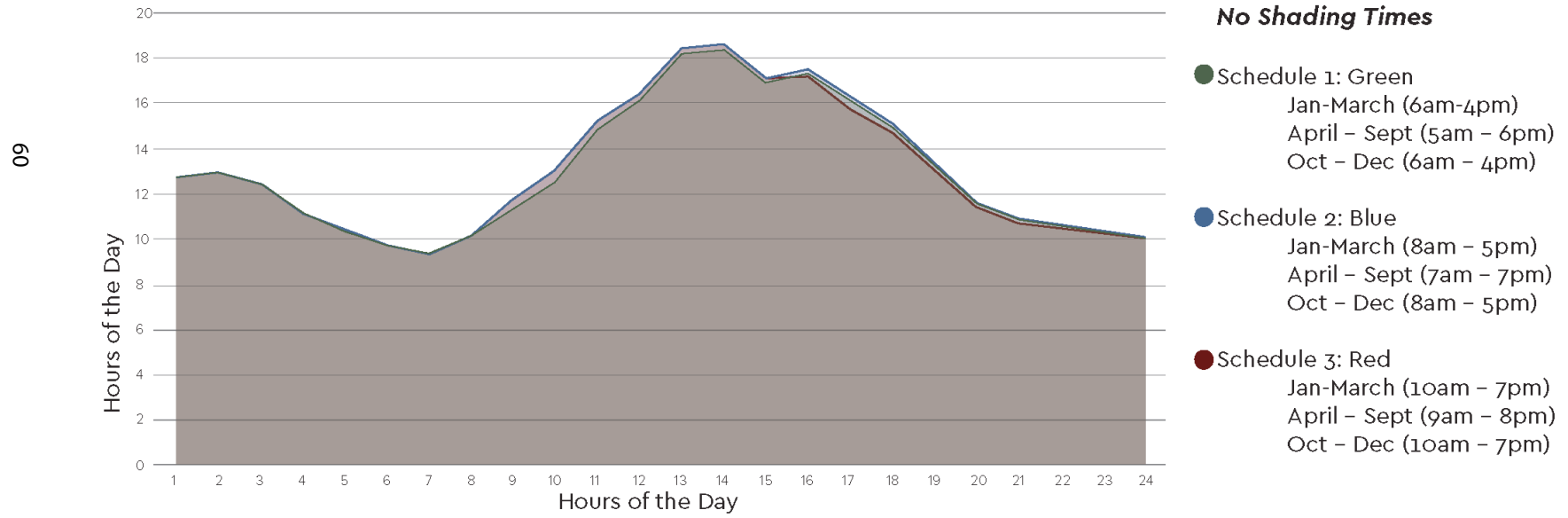

Figure 53: Shading Schedules

Shading Schedule 2 will provide more heating during the afternoon, which will allow the night time air to have a slightly higher

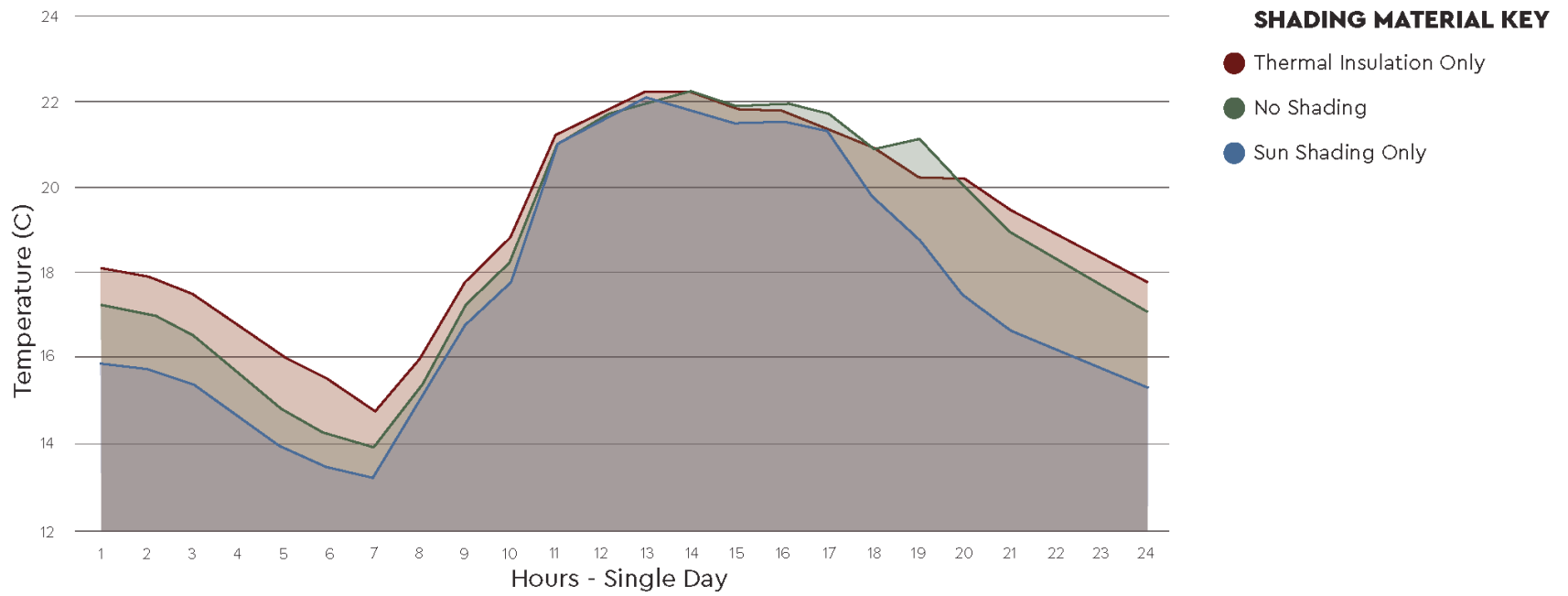
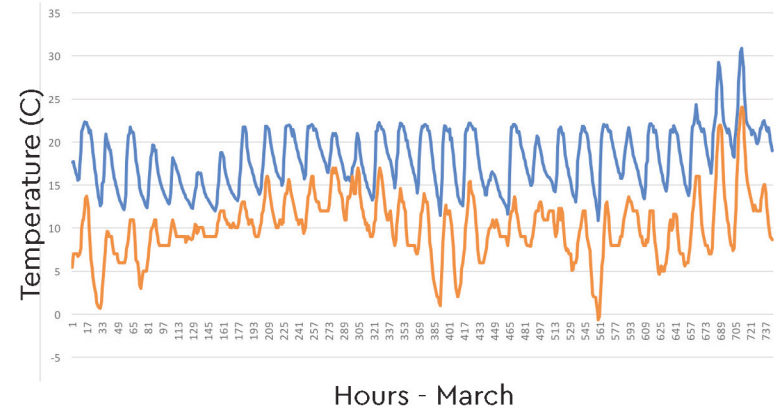
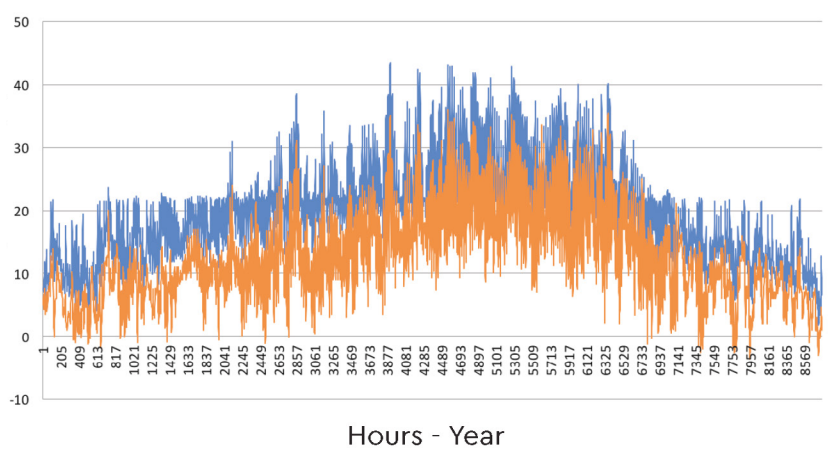

Figure 54: Shading Importance

Three different shading methods: No shading, solar shading only, and thermal insulation. Thermal insulation outperformed the other two.

Data

62



SHADING IMPORTANCE KEY

- Outdoor Dry Bulb Temperature
- Greenhouse Temperature with Thermal Insulation

Figure 55: Shading Importance

Thermal insulation is critical to maintaining optimal greenhouse growing temperatures throughout the year in Albany. These graphs more accurately represent the dramatic shift between the external temperatures and the internal greenhouse temperature.

Considerations for Design Development

The Pacific Northwest climate is mild, rainy, and cloudy, and it calls for passive solar heating approaches very different than those found in the high deserts of the American Southwest. When a design responds well to the clouds and rain, however, the warmth it provides is astonishing because the soft light of a cloudy day doesn't feel warm. Still, visible light carries substantial energy, and it's readily converted to the molecular vibrations we feel as heat when it's captured and stored in materials.

The projects of this course pursued three goals: First, to design park restrooms able to remain above freezing in Albany for two months in which they are currently closed, i.e. November and March; second, to create a community sunroom able to reach thermal comfort on April and May afternoons; and third, to create a community greenhouse able to maintain warmer-than-ambient temperatures in the early spring (January-March) and to avoid overheating in the summer (July-August).

The final drawings show schematic design elements that respond to Albany's climate (solar radiation, temperature, and rainfall patterns) and to individual sites (tree types, positions, heights, leaf-out and leaf-drop dates). Several important trends emerged from this work. First, the tilt of solar-collecting glass is shallower than in high desert designs, because solar intensity is greatest at the top of the sky dome (in other words, directly overhead) on cloudy days when fine droplets in the atmosphere scatter incoming radiation. Second, the orientation of solar-collecting glass ranges from southeast to southwest, because trees or buildings shade the southern sky at some sites. Since all of the sites held numerous trees or buildings, careful solar exposure investigations were used to size and position glass as well as to create the models that estimated performance. Third, thermal storage mass is well separated from the ground in most cases. In valleys with fine-grained soils, rainwater is easily wicked toward a building and underneath it, creating a persistent layer of high thermal conductivity that rapidly draws heat away from any stone or concrete floors in contact with it. Fourth, movable insulation for use at night is essential to every project. While movable elements can be expensive to install and maintain, nighttime heat losses through solar-collecting glass were great enough to reverse daily gains in the important months of November, February, and March. Although students investigated the use of highly insulated glass units, these greatly diminished solar heat collection. Each of these elements is visible in the final drawings.

Other essential elements, however, are not visible in the drawings, though they are represented in the EnergyPlus performance models. First, solar-collecting glass must have a high solar heat-gain coefficient (SHGC) in this climate. Glazing assemblies advertised as "high-performance" often have low SHGCs, limiting their abilities to admit heat, and these could not perform well in March and November. Instead, standard double glazing without Low-E coatings was generally more effective. Second, movable

insulation must have tight or interlocking edge connections to limit the flow of air to the glass behind it. Even small gaps at the edges allowed substantial heat loss, in the models, as warm air circulated behind the insulation and contacted the cold glass.

Finally, the projects showed that the designs are sensitive to other factors that could not be fully resolved during the course. The most important of these is infiltration, or the leakiness of a building to ambient air. Ventilation was a particular concern for the restroom and greenhouse projects, but students found that scheduled ventilation through opening of well-placed vents during relatively warm hours of the day allowed maintenance of warmer average temperatures than did higher, continuous infiltration through the building. At the same time, greater thermal mass allowed restrooms to avoid freezing while maintaining higher infiltration rates. The tradeoff between thermal massing and infiltration must be considered further in design development, especially since thermal mass is easily oversized in this climate.

The discovery that well designed restrooms could easily avoid freezing during the desired months, according to the best available solar and thermal models and across a number of different designs, was one of the most encouraging results of the course. The performance of the sunroom and greenhouse were also promising, but these were expected from precedents. At the same time, the information in this report is not necessarily sufficient to realize the documented performance in built form, and the instructor, Alexandra Rempel, encourages the City of Albany and affiliated architects to enlist further EnergyPlus modeling support from her (arempel@uoregon.edu) and/or engineers experienced with EnergyPlus if design development is undertaken for any of the projects. Most of the widely-used energy models (eQUEST, Sefaira, Diva) simplify thermal representations of solar energy, clouds, glass, and thermal mass too extensively for passive solar design, and to date, EnergyPlus is the only tool shown to represent the performance of built passive solar buildings accurately.

The students and instructor thank the City of Albany staff warmly for their interest in this work and for their access to city property and information, and they wish the city the best possible success with their passive solar futures.