



# CITY OF BOWIE TRAILS MASTER PLAN

Prepared by  
City of Bowie Department of Planning and Economic  
Development

Adopted May 2002





# City of Bowie

2614 Kenhill Drive  
Bowie, Maryland 20715

January 2003

RE: **City of Bowie Trails Master Plan**

Dear City of Bowie Trails User:

Enclosed please find a copy of the City of Bowie's recently adopted Trails Master Plan. This Plan represents many, many months of research, collaboration, meetings, analysis and review of previously established policies.

A primary objective of this Trails Master Plan is to identify ways to link the various neighborhoods and communities together and also to connect them to commercial/retail areas, schools, parks and other community facilities via a network of on-road and off-road trails. Furthermore, this Master Plan recommends the establishment of several service areas and the adoption of several new trail-related policies, as well as the continuation of numerous established programs to improve the trails network and the dissemination of information regarding City trails.

The City's Trails Master Plan also contains recommendations for different types of trails, including off-road trails, on-road trails, equestrian trails and water trails (a new concept). The Plan recommends the addition of approximately 65 miles of new trails, resulting in a total of nearly 111 miles of trail facilities available within the system.

Feel free to contact the City's Planning Department with any ideas, issues or concerns you may have about our trails program.

Please remember to practice safety when enjoying the trails in the Bowie area!

Thank you for your cooperation.

Sincerely,

Bowie City Council  
G. Frederick Robinson  
Mayor

p:\trailsmastpl\ndistublettr.doc

# TABLE OF CONTENTS

## CITY OF BOWIE TRAILS MASTER PLAN

	<u>Page</u>
<b>I. Background and Purpose</b>	<b>1</b>
Introduction	1
Goals and Purposes	2
A. Objectives of Trails Master Plan	2
B. What is a Trail?	3
C. The Need for Planning Trail Routes	4
D. Public Participation Process	5
<b>II. Inventory, Programs and Issues Related to Existing Trails System</b>	<b>6</b>
A. Trail Inventory Matrix and Map	6
1. City Trails	6
2. Prince George's County Trails	8
3. National Trails	9
4. Maryland Statewide Bicycle and Pedestrian Access Plan	10
5. Homeowners Associations (HOAs) Trails	11
6. On-Road Trails	11
7. Equestrian Trails	11
8. Sidewalks	12
B. Status of Existing City Programs	
1. Trail Markers Installation and Identification Program	12
2. Bike Rack Installation Program	12
3. City's Annual Trail Maintenance and Expansion Program (1997-2001)	13
C. Identification of Existing Issues	13

<b>III. Trails Plan Recommendations</b>	<b>15</b>
<b>A. Proposals</b>	<b>15</b>
1. Linking Older Neighborhoods Via Signed Shared Roadways (Signed Bike Routes)	15
2. Links to the WB&A Regional Trail	16
3. Service Areas	16
4. Comprehensive Design Standards and Guidelines	17
5. Trails Maintenance Program	17
6. Multi-User Trail Standards	18
7. Cooperate with Other Jurisdictions	18
8. Realignment of the Collington Branch Trail	18
9. Water Trails	18
10. Use of Utility Easements	19
11. Trail Materials	19
12. Grants for Trails	19
13. Trail Mapping and Database	19
14. Trail Identification System	19
15. Public Information	19
<b>B. New and Modified Recommended Trail Policies</b>	<b>19</b>
<b>C. Current Specific Trail Policies Recommended to Remain in Effect</b>	<b>21</b>
Alignment/Location	21
Design and Technical Standards	28
Governmental/Staff Coordination	31
User Groups	33
<b>D. City Programs</b>	<b>34</b>
1. Trail Markers Installation and Identification Program	34
2. Bike Rack Installation Program	34
3. City's Annual Trail Maintenance and Expansion Program	34
4. Other Programs to Reduce Bicycle Hazards	35
(i) Bicycle-Safe Drainage Grates	35
(ii) Railroad Track Crossings	35
(iii) Transition Areas	35
5. Staff Coordination	36
6. Community Information Display Boards	36
7. City of Bowie Website	37
8. City Designations and Support	37
(i) Trail Town USA Designation	37
(ii) Bicycle Friendly Community	38
(iii) Walkable Cities Program	38
Appendix I (Definitions)	39
Appendix II (Trail Rules)	41
List of Resources	42

## **I. BACKGROUND AND PURPOSE**

### **Introduction**

Located within the triangle of Washington, D.C., Baltimore and Annapolis region, the City of Bowie with a population of nearly 52,000 residents, is situated adjacent to one of the largest undeveloped greenways on the East Coast—the Patuxent River watershed. The Patuxent River, the third largest river in the State of Maryland, lies north and east of the City. The Fran Uhler Natural Area and the County-owned Patuxent River Park total more than 6,000 acres of open spaces along this water body, and the Patuxent Wildlife Research Center are destinations for bicyclists. As a result of its geographic location and the river boundary, and in addition to its linking various residential and commercial areas, one function of the trail system in Bowie, as well as that throughout Prince George's County, is to provide access to the greenways and blueways (water trails). Bowie's geographical location, coupled with the regional WB&A (Washington, Baltimore and Annapolis) Trail in the northern third of the City, provides an opportunity for the local trail network to link with trail systems leading beyond the friendly confines of Bowie. The City is fortunate also in that its location, in a broader scope, lies within the crossroads of several other regional trails in Anne Arundel County, Baltimore County, Montgomery County, Prince George's County, Washington, D.C. and northern Virginia, as well as two national trails—the American Discovery Trail and the East Coast Greenway.

The City is in the advantageous position of having a hierarchy of trails within and immediately adjacent to its boundaries. In 1996, according to the City's Recreation Master Plan, the ratio of trails mileage per population was 1-mile/3,000 residents. In 2002, given an estimated population of 52,000 and the 47 miles that have been identified, the current ratio is 1-mile/1,100 residents. In other words, in 1996, there was approximately 1/3 of a mile of trail per 1,000 residents; presently, there is nearly one mile of trail per 1,000 residents. This newer ratio is reflective of: the construction and opening of the WB&A Trail; the construction of several miles of trails by the City and the Bowie Town Center developer; and, the classification of existing trails which may not have been earlier identified.

This Trails Master Plan proposes to take the existing system of trails and expand it to achieve the following:

- Provide linkages to the WB&A Trail;
- Expand the trail network that exists in the vicinity to the region;
- Identify a system of on-road trails that will connect residential neighborhoods, parks, open spaces and commercial areas with existing off-road trails;
- Recommend a water trail (blueway) within the Patuxent River; and,
- Identify service/rest areas throughout the area.

**Goals and Purposes**

The goals and purposes of the City's Trails Master Plan are to:

- Inventory the existing system of trails within, through and immediately adjacent to Bowie;
- Develop a comprehensive and thorough approach in continuing to expand this network, while properly maintaining our present trail system;
- Provide this network to meet the present and future needs of users of the trails system; and,
- Apply acceptable trail design standards and best management and installation practices.

**A. Objectives of Trails Master Plan**

The objectives of the City of Bowie Trails Master Plan are to:

- Complete an inventory of existing trails within the City and immediately contiguous areas;
- Describe the City's current trails program;
- Describe the relationship between the City's trail program and those in the region;
- Establish a framework for regional connections and local feeder trails;
- Commit to the continued development of a comprehensive multi-user system of trails;
- Establish a schedule for trails maintenance and expansion;
- Develop and implement design standards for trail, bicycle and pedestrian facility improvements;
- Provide updates to this Trails Master Plan that reflect current and projected residential and commercial growth;
- Continue to provide trail information to the community; and,
- Ensure that off-road trails comply with the provisions of the Americans with Disabilities Act.

Creating, expanding and maintaining a continuous and connected trail system has the potential to:

- Promote the concepts of Smart Growth;
- Reduce vehicle trips;
- Provide an integrated network to reach daily destinations;
- Tie together residential communities, commercial activities, parks, schools, recreational areas and other public uses and spaces;
- Provide recreational opportunities; and,
- Enhance the quality of life of Bowie residents.

#### **B. What is a Trail?**

A trail may take various forms, based on its function, surface, users, area within which it is located and environmental features within its corridor. A trail could be merely a narrow, dirt path in a cleared or wooded area; or it could be something more formal, such as a bikeway on a portion of a road, either undesignated or delineated by signage; or, a trail could be a multi-use facility for pedestrians, bicyclists, roller bladers or equestrians separated from vehicular traffic. This Trails Master Plan relates to off-road and on-road trails and does not address the current sidewalk system. The trails and sidewalk systems are two different systems serving different user groups. While the sidewalk system is primarily for pedestrians, the trail system is intended to serve a variety of users, including those identified above.

Trails also serve multiple purposes, such as:

- Enhancing and promoting the use of open space;
- Providing recreational opportunities, thereby increasing public health opportunities for the community through exercise;
- Providing opportunities for children to bike or walk to schools, parks and other public spaces;
- Providing opportunities for people of all ages to bike or walk to commercial centers;
- Providing a transportation function for commuters. (For example, the WB&A Trail is intended to serve both a recreational purpose for joggers, walkers, bicyclists, roller bladers and equestrians, as well as people commuting to their places of employment.); and,

- Providing, where possible and feasible, a potential separation between pedestrians, bicyclists and equestrians from motor vehicles.

The surface of a trail may be determined by existing or anticipated usage, cost constraints and/or environmental characteristics and features of the area. Examples of different trail surfaces exist in the City, and include: unimproved dirt trails in Tanglewood Park; wood chip trails in low-lying areas of Pope's Creek Park; asphalt trails in and around Allen Pond Park; and, boardwalk trail sections around the New Town Center Pond and along MD Route 197. Crushed stone or wood chip trails may be more appropriate in wooded settings because they are considered more environmentally acceptable, softer and therefore safer than an asphalt trail and have a lower installation cost than a hard surface trail.

### **C. The Need for Planning Trail Routes**

Occasionally, opportunities arise to locate trails precisely where they may provide the optimum benefit. Existing development and environmental constraints play a major role in determining the locations and feasibility of trail routes. In some instances, trails follow utility rights-of-way, corridors of former rail lines, waterways or, if sufficient right-of-way exists, along streets or highways. In these cases, adopting an existing corridor may be easier, less costly and have fewer environmental impacts than acquiring new land for trails.

To create a more balanced transportation network, which provides people with broader opportunities for mobility and recreation, transportation planning under the Federal TEA-21 funding program involves the consideration of social, cultural, environmental and economic factors. The County General Plan includes the recommendation of multi-modal transportation policies. As a result of these types of policies, trails, and their locations, alignments and functions funded under various programs, can have an effect on numerous aspects of the health, safety and welfare of a community.

A variety of situations that integrate a trail into a neighborhood or community include the proximity to schools, shopping centers, community/public uses and parks. This Trails Master Plan attempts to provide this integration by recommending expansion of the existing trail system by additional off-road trails as well as the identification of an on-road trails network.

The positive economic benefit that trails and trail users have on area economies is a message that needs to be communicated. The National Park Service performed a study of the economic impacts of three rail-trails located in three different states. Results of the study demonstrated that "the total economic impact of a trail involves the creation of new trail-related jobs and the expansion of existing businesses related to travel, equipment, clothes, food, souvenirs and maps." Other economic studies of trails throughout the country have found that users spend their dollars in communities through which they are traveling. The conclusion of all of these studies is that trails and their users do have positive impacts on local and state economies.



In addition to the economic benefits, studies have found that trails situated near residential areas have a positive impact on housing value as well as improving the quality of life of residents.

**D. Public Participation Process**

As part of the trail plan preparation process, periodic meetings were held with representatives of the local biking community as well as with representatives of Prince George's County and the State. In addition, a public outreach meeting was conducted and briefings were previously provided to the Citizens Recreation Committee, Bowie Advisory Planning Board and City Council to solicit information and to identify issues. After a workshop with the City Council in March, 2002, staff continued to refine this Trails Master Plan and to work with the local user groups. The public participation process is on going, and continued solicitation of, and input from, user groups is necessary for successful implementation of this Master Plan.

## **II. INVENTORY, PROGRAMS AND ISSUES RELATED TO EXISTING TRAILS SYSTEM**

### **A. Trail Inventory Matrix and Map**

The City has drafted an inventory of all trails within and immediately adjacent to the corporate boundaries, resulting in a "trails matrix" and map. This matrix inventory encompasses improved trails (asphalt surface, sidewalks functioning as trails, shoulders along roadways used for trails or other on-road trails), unimproved trails (dirt trail, wood chip trail, etc.), as well as trails on public lands (City of Bowie, Maryland-National Capital Park and Planning Commission, State of Maryland) and under private ownership (community homeowners associations [HOAs]). The inventory also includes trail characteristics such as the mileage of trail segments, trail condition, surface and width and adjacent terrain and topography. A GIS-produced base map has been prepared (City of Bowie Trails Master Plan Map) (Attachment 1).

The present characteristics of the trails network within and adjacent to the City include nearly 47 miles of off-road trails, including improved and unimproved trails, trails under HOA jurisdiction and approximately 5.5 miles of trails used by equestrians. Trail surfaces range from asphalt to crushed gravel, dirt and wood chips. The terrains over which these trails pass include extremely hilly areas, moderately hilly areas, areas with a slight incline and areas that are generally flat. The latter comprise the majority of the trails system throughout the City. There is a broad age range of the trails: for the most part, the newer trails have been constructed within and as part of a development and are HOA trails. The publicly owned trails are generally the older trails. (Exceptions include recently completed trails along Health Center Drive, through the Board of Education property on Mitchellville Road, on the west side of Northview Drive, and along Nottingham Lane.) Some older public trails, such as those found in Whitemarsh Park, have undergone rehabilitation and will continue to be the focus of maintenance efforts by the City in years to come. The trails along MD Routes 197 and 450 are within State highway right-of-way and are to be maintained by the State Highway Administration (SHA). The City has been and will continue to work with SHA in bringing to their attention what areas of these trails are in need of maintenance. As noted above, trails within and adjacent to the City are under several jurisdictions, which include: SHA, Park and Planning's Department of Parks and Recreation, the City and Homeowners Associations.

#### **1. City Trails**

In early 1995, the City Council appointed an eight member Transportation Planning Task Force, whose purpose was to provide a comprehensive vision for the direction transportation within the City should take in a time frame of up to the year 2015. As part of its information-gathering effort, the Task Force prepared and distributed a survey questionnaire to solicit community-wide input regarding the various components of the transportation system throughout the City, including trails. Results of the survey, as they related to trails and the pedestrian/bicyclist system, indicated that, although trails and sidewalks

were highly rated; they were not adequately inter-connected to allow smooth and safe movement between the numerous parks, community facilities and recreational facilities. Nevertheless, respondents to the survey indicated that:

47% would either consider walking or biking to work, or would actually walk or bike to work, if it were safe and convenient; and,

20% currently (1996) walk or bike for shopping or recreation trips.

At the conclusion of its effort, the Task Force offered nine recommendations to improve pedestrian and bicycle circulation in Bowie. Those recommendations are contained below in the section of this document titled "Previously Adopted Policies".

In addition to the findings and recommendations reached by the Transportation Planning Task Force, Bowie's trail system was also studied as part of the research and preparation of the City's Recreation Master Plan (1996-2005). The Immediate and Long-Range Needs of active recreational activities, according to the Recreation Master Plan do not address or identify the continued maintenance and expansion of the City's trail system. The Plan does, however, recommend the collection of fee-in-lieu amenities designated for special recreational facilities and amenities from developers. The Recreation Master Plan states, "Some fee-in-lieu money should also go to the construction of City-wide and regional biking/running trails." (page xi)

The City's Recreation Master Plan compares the mileage of hiking/biking/running trails (all surface types) in Bowie with those in other cities of comparable size throughout Maryland. The mileage of Bowie's trails contained in the Recreation Master Plan results in a ratio of 1 mile of trail for every 3,000 residents. The 1996 ratios for the other cities reviewed are as follows:

<u>City</u>	<u>Trail Mileage/Population Ratio</u>
Columbia	1 mile/1,100 persons
Gaithersburg	1 mile/6,000 persons
Laurel	1-mile/4,200 persons

Bowie's Recreation Master Plan recommends that, while recognizing the current ratio is adequate, the City should continue to maintain at least the ratio of 1 mile of trail/3,000 persons. However, the issue that will become more significant with respect to the City's off-road trail system, as a result of age, is the maintenance of that system and the programming and resources for funding.

In looking at the City on an area-wide basis, the Recreation Master Plan noted that, in 1996, there was a deficit of approximately 1 mile of trail in Area III (the area south of US Route 50). According to the Recreation

Master Plan, if no new trails were constructed in Area III by the year 2005, the deficit will increase to more than 3.5 miles of trails. Additionally, Area II, located between the WB&A Trail and US Route 50, would experience a deficit of more than 0.5 mile of trail without the provision of additional trails. Area I, north of the WB&A Trail, had a trails surplus of approximately 1 mile. Citywide, according to the Recreation Master Plan, a deficit of nearly 3.5 miles of trails would exist by the year 2005 without any new trails being constructed. Without addressing these deficits, the City may place itself in jeopardy of losing its designations as a Bicycle Friendly Community and a Trail Town USA, since these organizations recognize the need to provide a continually expanding trail system. The installation of five new trail segments by the City, plus the trails provided by The Simon Property Group in conjunction with the construction of the Bowie Town Center retail project, resulting in nearly 2.25 miles of new trails, are ways to eliminate this deficit.

Two other significant improvements that have had positive impacts on eliminating missing links while providing improved pedestrian and bicyclist safety are the construction of the "hiker/biker" bridge over U.S. Route 50 and the approved bridge over MD Route 197.

The Recreation Master Plan reviews anticipated new recreational amenities to be provided by developers by the year 2005 through the land development process. The Plan recognizes that several recent residential and commercial land development projects include public and HOA trails.

## **2. Prince George's County Trails**

The objective of the Trails Plan component of the 1991 Bowie-Collington-Mitchellville Master Plan "is to develop a continuous system of trails which will serve the recreational and commuter needs of County residents." The Area Master Plan also cites the City's previous Recreation Master Plan (1987), in which the expansion of the hiker-biker trail system is defined as a pressing recreational need.

The Bowie-Collington-Mitchellville Master Plan recognizes four trail classifications to accommodate use by hikers, bicyclists and equestrians:

"Class I: Trails located in rights-of-way or easements which are not shared with motorized vehicles. (The WB&A Trail is an example of a Class I trail.)

Class II: Trails located in shared or common rights-of-way with other vehicles but with barriers to separate the bicycle path from vehicular traffic. (The new trail constructed along new MD Route 450, west of MD Route 193 is an example of a Class II trail.)

Class III: Trails located with rights-of-way without physical barriers to separate them from vehicular traffic. These trails are identified by signs and possibly by a stripe painted on the road surface. (An example of a Class III trail is Powder Mill Road.); and,

Class IV: Multiuse trails located within the stream valley park system and utility rights-of-way." (The Anacostia Stream Valley Trail is an example of a Class IV trail.)

The Area Master Plan recognizes the potential for the development and expansion of new trails to serve both recreation and transportation purposes through the use of public funds through the capital improvement program and public benefit contributions from developers via the development review process. An example of the application of this technique includes the trail system cited in the Area Master Plan for the Bowie Town Center.

The WB&A Trail, whose construction was supervised by the M-NCPPC Parks Department, is an example of a regional trail which is also a segment of two national trails planned to traverse the Bowie area: the American Discovery Trail and the East Coast Greenway.

The Area Master Plan recommends several guidelines to implement the continued development of the trail network in and around Bowie. These are discussed below in the "Trails Plan Recommendations" section of this document.

### 3. **National Trails**

As noted above, in addition to its regional function, the WB&A Trail has been envisioned to serve as a portion of two national trails, specifically the American Discovery Trail (ADT) and the East Coast Greenway (ECG). Both of these trails have been designated as National Millennium Trails via the National Millennium Trails Program. This program is a partnership between several federal agencies, such as the Department of Transportation, the Bureau of Land Management and the National Park Service, as well as private and non-profit organizations. The ADT and ECG are two of 15 national trails designated as National Millennium Trails.

The ADT, an ocean-to-ocean trail first proposed by the American Hiking Society in the fall of 1989, is planned to originate in Cape Henlopen State Park, Delaware and terminate in Point Reyes National Seashore, California (Attachments 2, 3 and 4). Along the way, the ADT is proposed to split in to northern and southern alignments west of suburban Cincinnati, Ohio and rejoin as one corridor in the western suburbs of Denver, Colorado. Totalling a distance of more than 6,300 miles, the ADT will be the first coast-to-coast, non-motorized trail, and

will lead to 14 national parks and 16 national forests. A unique feature of the ADT is that it is mostly on publicly owned lands.

In the Bowie area, the ADT will enter eastern Prince George's County by crossing the Patuxent River in the vicinity of the WSSC pumping station north of the Bowie Race Track. The ADT will follow the WB&A alignment as a tunnel under Race Track Road, crossing over MD Route 197 north of the Bowie Golf Course and over the Horsepen Branch, Pope's Creek Railroad and High Bridge Road in the vicinity of Mockingbird Lane. At this time, however, the interim route of the ADT enters Bowie via Governor Bridge Road.

The East Coast Greenway, first envisioned in 1991, is a trail of approximately 2,600 miles planned to link Calais, Maine with Key West, Florida. It is foreseen to travel through Maryland in one of two alignments: Option 1 enters Maryland from northwestern Delaware, heads south to incorporate the Jones Falls Trail, leading into and through the City of Baltimore. South of Baltimore, the BWI (Baltimore-Washington International Airport) Trail and the B&A Trail (Baltimore and Annapolis) join with the WB&A Trail to form the East Coast Greenway alignment. Option 2 involves a trail corridor on the Eastern Shore, passing through Elkton, continuing south, to east of Chestertown, and through Centreville to the Cross Island Greenway. The ECG would cross the Chesapeake Bay via the Bay Bridge and join the Broadneck Trail and B&A Trail, continue northwest, intersecting the WB&A Trail in eastern Anne Arundel County. At this point, the ECG alignment follows the same route as the WB&A Trail and the ADT through the Bowie area. The ECG, however, is envisioned to turn north on MD Route 197 and continue through the Patuxent Wildlife Management Area. An alternative route is along the WB&A Trail to High Bridge Road, where the ECG would lead into Huntington and continue on to Greenbelt.

The overseeing of both of these national trails is being handled by their respective organizations; the ADT project is being managed by the American Discovery Trail Society, while the East Coast Greenway Alliance is coordinating the development of the ECG. The status of each of these national trails is one of continuous involvement. In the Bowie area, the alignments of each have been either constructed or designated. As noted above, especially for the East Coast Greenway, two possible alternate alignments have been designated through Maryland. The residents and businesses in the Bowie area will be fortunate to have two national trails as part of the regional and local trail system.

#### 4. Maryland Statewide Bicycle and Pedestrian Access Plan

The Maryland Department of Transportation has been in the process of preparing a Statewide Bicycle and Pedestrian Access Plan (SBPAP). This Plan, mandated by the State Legislature, is a two-year, three phase project, with the goal of producing a 20-year program that will assist in guiding future transportation projects statewide.

Phase I in the development of the SBPAP, completed in 2001, was the Policy Vision phase, since it defined the scope of the project and Plan, identified and collected input from stakeholders involved in the process and resulted in a vision statement intended to guide development of the Plan and bicycle and pedestrian planning activities.

Phase II of the SBPAP, which concludes in the Spring, 2002, has been identified as the Facilities Inventory phase. The purpose of this phase is to inventory and analyze the present pedestrian and bicycle infrastructure and road conditions along State highways throughout Maryland. The conclusion of this task will result in the development of recommendations to be included in the SBPAP.

Phase III has been labeled as Development of the Plan. Anticipated to be completed in October 2002, this phase will identify actions that will better conditions for pedestrians and bicyclists traveling along State roads. This phase will also include mapping, a priority list of road improvements, new State policies for pedestrians and bicyclists, a model ordinance promoting bicycle and pedestrian access and safety, and short term (5 to 10 years) and long term (15 to 20 years) goals.

**5. Homeowners Associations (HOAs) Trails**

Trails in this category include those that have been constructed as part of a residential community, located on HOA-owned property and are maintained by the respective HOAs. Although typically a hard surface, these trails are usually not as wide as those owned and maintained by the public sector. However, they do serve as a link to the municipal trail system and provide community residents with a recreational amenity and opportunity. Approximately 10 miles of HOA-owned trails have been inventoried in the Bowie area.

**6. On-Road Trails**

Presently, no on-road trails have been identified in the City, nor have any City streets been signed as bike routes. However, by State law, bicyclists are not permitted on sidewalks and must ride in the street. This Trails Master Plan recommends that a comprehensive network of on-road trails be established to connect older established neighborhoods with each other and the uses within.

**7. Equestrian Trails**

Approximately 5.5 miles of equestrian trails have been identified on publicly owned property. The WB&A Trail alignment was designed and constructed to allow equestrians. Other land used by equestrians is that owned by the Park and Planning Commission, located north and west of the City's Public Works site (and south of the WB&A Trail) and between the "O" and "Y" sections and the Patuxent River. This Trails Master Plan recommends extensions of the equestrian trails network.

**8. Sidewalks**

The City has an established network of sidewalks along many types of streets in the local road hierarchy. The provision of sidewalks has been handled through the City Code. Further, during the review process of new development projects, the City has historically and consistently recommended that sidewalks be included. While sidewalks have traditionally been less prevalent along County roads and State highways, a trend to provide off-road pedestrian/biking opportunities has recently been evolving in the Bowie area. Improvements to Mitchellville Road (a County road, between MD Route 197 and Mt. Oak Road) included a trail and wide sidewalk. With respect to the State road system, the design of relocated MD Route 450 includes an off-road trail from MD Route 193 to Stonybrook Drive. These projects are local examples of the recognition by the County and the State Highway Administration that off-road accommodations should be provided for pedestrians and bicyclists.

**B. Status of Existing City Programs**

**1. Trail Markers Installation and Identification Program (Attachment 5)**

More than 20 trail markers have been installed in the following locations:

- Whitemarsh Park;
- Allen Pond Park;
- Black Sox Park and the adjacent Glen Allen community;
- along the existing trail adjacent to MD Route 450 (between Millstream Drive and MD Route 197); and,
- along the existing trail adjacent to MD Route 197 (between MD Route 450 and Holiday Lane).

**2. Bike Rack Installation Program (Attachment 6)**

Under a State Highway Administration program, the City obtained and has installed 20 bike racks in the following locations:

<u>Location</u>	<u>Number of Bike Racks</u>
Allen Pond Park	4
Black Sox Park	3
Buckingham Park	3
City Hall	2
New Town Center Pond	2
Whitemarsh Park	<u>6</u>
	20



In addition, bicycle racks have been installed at commercial establishments. Twelve bike racks, able to accommodate up to 116 bicycles, have been provided in the Bowie Town Center commercial retail development, while two bike racks have been installed at the Hoyt's Theater in Bowie Crossing.

### **3. City's Annual Trail Maintenance and Expansion Program (1997-2001)**

For the last few years, an annual average of over \$25,000 has been provided in the City's adopted Capital Improvement Program (CIP) for the continuous maintenance of City trails. City maintenance responsibilities include:

- Maintenance and repair of trail surfaces as needed;
- Sweeping trails on a monthly basis;
- Cutting grass adjacent to City trails a minimum of twice monthly; and,
- Plowing snow from trails (after completing snow removal from City streets).

A significant task in the reconstruction of the trails in Whitmarsh Park in 1999 involved the milling of the trail surface, which had buckled in sections as a result of tree roots growing beneath the trails. This damage was magnified over the years by winter conditions of freezing and thawing. As a result, an average lifespan of approximately 15 years may be anticipated for City-maintained trails. The City also maintains off-road trails for other jurisdictions.

In the past, students, scouts and other volunteers have provided assistance to City staff in litter removal along trails and installing trail markers. Using the resources of service clubs, scout troops, civic clubs, church groups, homeowners associations and other community organizations can provide valuable assistance supplemental to the efforts of City staff.

### **C. Identification of Existing Issues**

The awareness and recognition of issues related to the trail system in and around the City have become more easily identifiable after much discussion with and input from user groups, officials from the County, State, other local jurisdictions, residents and City organizations. As a result, the following have been highlighted as existing issues within the City's trail system:

- Lack of a trail system in the older residential sections of Bowie that would link together the various neighborhoods, schools and parks;
- Need for more access points to, and rest areas along, the WB&A Trail;
- Lack of comprehensive design standards and guidelines for off-road and on-road multi-use trails;
- Need for enhancement of a Trails Maintenance Program;
- Need to incorporate more user groups into the trail system, including equestrians;
- Need to establish better working relationships with County and State jurisdictions to improve communications and sustain the development of the regional trail network;
- Need to relocate the Collington Branch Stream Valley Trail; and,
- Lack of potential for establishing trails within utility rights-of-way and easements, where feasible.

It is a goal of this Trails Master Plan to positively address each of these issues through the recommendation of new proposals, and new or amended policies and programs.

### **III. TRAILS PLAN RECOMMENDATIONS**

The new City Trails Master Plan includes recommended proposals, policies and programs in response to issues raised in this report. The proposed Trails Master Plan Map illustrates new or revised trail alignments also recommended by this Trails Master Plan.

#### **A. Proposals**

- 1. Linking Older Neighborhoods Via Signed Shared Roadways (Signed Bike Routes). In areas where construction of a new trail is not possible or feasible, a means of linking various off-road segments of the City's trail system is to employ the use of signed shared roadways. The purposes of a shared road facility include:**

- **Allowing bicycles access to all streets, regardless of whether or not designated bicycle facilities are provided; and,**
- **Providing access to the numerous destinations throughout the City.**

Shared roadways are appropriate on local streets in residential areas with low vehicle speeds and volumes and where local streets are needed as part of a designated trail route to provide continuity and linkage throughout the City. An on-road shared bike route system also provides an opportunity to connect residential areas with each other and with commercial and public uses in portions of the City which are presently developed and where the opportunity to construct off-road trails is less feasible. In the older residential communities, as well as in more recently developed areas, on-road bike routes should connect neighborhoods, open spaces, commercial and employment centers, recreational facilities, schools and parks, and other regional trails or destinations. For the above reasons, the identification of shared, on-road bike routes is recommended along the following City streets: Alameda Drive; Aloha Place; Arden Forest Lane; Atlantis Drive; Belair Drive; Buckingham Drive; Chapel Forge Drive; Clearfield Drive; Dunwood Ridge Terrace; Dunwood Valley Drive; Enfield Drive; Everst Drive; Heritage Boulevard; Jenkins Ridge Road; Jennings Mill Drive; Kembridge Drive; Kenhill Drive; Millstream Drive; Moylan Drive; New Haven Drive; Nashua Lane; Old Barn Road; Old Collington Road; Orchard Run (between Race Tack Road and Ox Farm Court); Peach Walker Drive; Perrell Lane; Pittsfield Lane; Pointer Ridge Drive; Rockledge Drive; Rustic Hill Drive; Stonybrook Drive; Superior Lane; Tulip Grove Drive; Whitehall Drive.

(Since U.S. Route 301 will be upgraded within the next several years, the potential exists for a grade-separated intersection at either Heritage Boulevard or Harbour Way. An on-road bike route is recommended along the roadway where the elevated link to the east side of U.S. Route 301 is provided. This will allow access to Prince George's Stadium at

either the main entrance along Ball Park Drive or via the north fringe parking lot on Governor Bridge Road.)

**On-road bike routes should also be provided along the following County roads:** Chestnut Street (into and through Huntington); Church Road (between MD Route 450 and Westview Forest Drive); Fletechertown Road; Governor Bridge Road; High Bridge Road (from the WB&A Trail to Chestnut Street); old Mt. Oak Road (post realignment, from Nottingham Lane to the A-44 right-of-way); Old Chapel Road (between MD Route 197 and Race Track Road); and, Race Track Road.

To provide bike access to Huntington from the east, Eleventh Street (MD Route 564) should be delineated as a bicycle route from MD Route 197.

These shared roadways should be identified by the installation of "Share the Road" signs (Attachment 7) and/or "Bike Route" signs (Attachment 8) to define their purpose and use and to call to the attention of motorists that bicyclists may be traveling along the road.

On County roads and State highways that have been designated as shared roadways, the use of curb-slot inlets, or the installation of bicycle-safe grates should be provided over roadway drains for bicyclist safety and to minimize bicycle damage.

2. **Links to the WB&A Regional Trail.** Since the WB&A Trail is a regional segment of two national trails (the American Discovery Trail and the East Coast Greenway), to provide improved access and thereby increase its usage, links to this regional facility are recommended in the following locations:

- Saddlebrook West: (bridge connection previously approved as part of the land development review process);

- MD Route 197: (in the form of an on-road shared bike lane/shoulder in both the northbound and southbound directions);

- Fladung Property: (This connection would involve the construction of a 10-foot wide hard surface trail and an adjacent/parallel equestrian trail through this City-owned property on Old Chapel Road. This site is envisioned to be a local trail access point, which would include on-site parking for trail users.)

3. **Service Areas.** Because of the potential regional and national significance and usage, and recognizing that the WB&A Trail will additionally be used by local residents, a rest/service area is recommended at its eastern end, between Race Track Road and the

**Patuxent River.** Service areas potentially could include rest rooms, vending machines and possibly permitting a mobile food, snack or ice cream vendor on the site. (The siting of a service/rest area in this location would complement the existing facilities at the Glenn Dale Recreation Center.) An alternative location for a rest/service area along the WB&A Trail is on a 2±-acre parcel owned by the Park and Planning Commission that came out of the Nazario Woods subdivision.

Service areas are proposed in three other locations as well: **Pope's Creek Park, the Hopkins Property and Foxhill Park.**

The establishment of a network of service/rest areas throughout the planning area would enhance and promote the usage of the trail network. These recommended service/rest areas would complement the facilities at Allen Pond Park, which presently serve this purpose.

Since one of the recommendations of this Trails Master Plan is to identify the Patuxent River, from the future WB&A Trail crossing to Governor Bridge Road, as a potential Water Trail, **a rest/service area should be provided on publicly owned land in the vicinity of Governor Bridge Road.**

4. **Comprehensive Design Standards and Guidelines.** The adoption of comprehensive design standards and guidelines for off-road and on-road multi-use trails, in accordance with those set forth by the American Association of State Highway and Transportation Officials (AASHTO) in the Guide for the Development of Bicycle Facilities, published in mid-1999 is recommended. In this publication, AASHTO set forth its engineering judgments as guidelines for the construction of trails and paths, which have been adopted as standards by some jurisdictions (Attachment 9).

Where off-road trails cross signalized intersections, to facilitate ease and safety at these locations, the installation of bicycle and pedestrian crossing signals, such as push buttons, bicycle sensitive signal detectors and/or special markings to identify traffic instructions and road hazards should continue to be encouraged.

5. **Trails Maintenance Program.** Enhancement of the Trails Maintenance Program is needed to set forth the budgetary framework necessary to provide continuous trail maintenance on an annual basis. A staff level process is in place to begin identifying the locations, types of improvements and estimated costs to maintain segments of the trail system. When a trail segment has been targeted for maintenance or improvement, the width of these renovated segments should be 10 feet. (A 10-foot wide improved surface trail is now the minimum being recommended by the Park and Planning Commission.)

6. **Multi-User Trail Standards.** Extension of the off-road trail network should include provisions to accommodate a variety of users, including equestrians, roller bladers, persons with physical disabilities, and others. To accommodate equestrians, a separate, parallel trail should be constructed in accordance with the standards in Attachment 10 alongside an improved trail extension. Since it is a goal that the trail network includes a broader range of users, the width of hard surface trail extensions should be increased to a minimum of 10 feet.
  
7. **Cooperate with Other Jurisdictions.** Work closely with the trail staffs of Prince George's County, Anne Arundel County and the State Highway Administration (SHA). City staff has been and will continue to be working closely with the staffs of each of the aforementioned jurisdictions. The City is represented on the Prince George's County Bicycle and Trails Advisory Group (BTAG) and on numerous committees of that group. In addition, City staff has met with staff from Anne Arundel County regarding the Patuxent River bridge extension of the WB&A Trail and the alignment of the East Coast Greenway. The City also has worked with SHA officials in relation to the designation of a shared shoulder/bike trail along MD Route 197 to the WB&A Trail, Bowie State University and the MARC station on campus.
  
8. **Realignment of the Collington Branch Trail.** Due to several factors, including severe environmental constraints and related increased costs, budgetary issues at the County level and resident opposition, the alignment of the Collington Branch Stream Valley Trail should be shifted to be within the A-44 right-of-way. This realignment has fewer, less severe environmental conditions and will provide improved direct access by future user groups. An earlier initiative is to construct a trail in the A-44 right-of-way from Central Avenue into the Woodmore Estates residential project under development. Later initiatives include construction of a trail through the A-44 section in Woodmore Highlands and Westview, with eventual construction of this trail as property along the A-44 alignment is subdivided.
  
9. **Water Trails.** Encourage the development of Water Trails. Water trails, or blueways, are routes along a river, stream, lake or other body of water navigable by canoe, rowboat, kayak or other similar craft. Water trails provide several important benefits, such as: educational opportunities for outdoor enthusiasts; recreational opportunities; promoting of tourism; encouraging good stewardship practices; and, increasing volunteerism in habitat clean-ups. This Trails Master Plan recommends that the Patuxent River be designated as a Water Trail, and identifies a route between the WB&A Trail and Governor Bridge Road for this purpose. To accommodate this water trail, rest/service areas are recommended at the two aforementioned locations.

and bicyclists that each has the right to use the roadway. Since bicyclists, as a matter of practice, know to ride close to the edge of pavement, bike lane delineation on City streets is not necessary.

2. Relocation of the Collington Branch Stream Valley Trail to an alignment within the A-44 right-of-way is preferable since it would result in fewer impacts to environmental features and more centrally located to residential areas and users.
3. Since the lighting of trails would encourage usage nearly round the clock and creates the potential for increased maintenance issues, this feature is not warranted.
4. Due to increased trail usage by broader range of user groups, the width of off-road, improved trails is recommended to be increased from eight feet to at least 10 feet.
5. Since M-NCPPC has revised its thinking with respect to the future of PT-1 as a transportation corridor and has approved development within this alignment, the potential for the installation of trails through this alignment is diminished.
6. From an engineering perspective, unless they would have minimal or no impact, trails should not be permitted in existing drainage ways in the older areas of the City.
7. On County roads and State highways that have been designated as shared roadways, the use of curb-slot inlets, or the installation of bicycle-safe grates should be provided over roadway drains for bicyclist safety and to minimize bicycle damage.
8. The establishment of a network of service/rest areas throughout the planning area would enhance and promote the usage of the trail network.
9. Where off-road trails cross signalized intersections, to facilitate ease and safety at these locations, the installation of bicycle and pedestrian crossing signals, such as push buttons, bicycle sensitive signal detectors and/or special markings to identify traffic instructions and road hazards should continue to be encouraged.
10. When an existing trail or trail segment has been targeted for maintenance, repair or improvement, or when a new trail is constructed, the minimum width of the trail should be 10 feet.
11. Extension of the off-road trail network should include provisions to accommodate a variety of users.

12. Where missing links exist in the trail network, it is recommended to continue to seek permission from utility companies to use their rights-of-way and easements for trails.

### **C. Current Specific Trail Policies Recommended to Remain in Effect**

The previously adopted trail-related policies listed below are recommended to be retained in this Trails Master Plan and have been divided into the following categories: Alignment/Location; Design and Technical Standards; Governmental/Staff Coordination; and, User Groups.

#### **Alignment/Location**

1. **From a pedestrian/bicycle perspective, Bowie State University, the MSTC and Prince George's Stadium should be integrated with the City.**

COMMENT: Recommendations contained in this Trails Master Plan support the extension of the trail system to each of the three destinations cited above.

2. **Pursuant to the Area Master Plan, a pedestrian/bicycle trail should be provided along the entire length of MD Route 193.**

COMMENT: An off-road trail was constructed along MD Route 193 in conjunction with the development of the Marleigh residential community. This is an example of a trail being planned and designed as part of the land development/subdivision review process. As other parcels of land in this corridor are submitted as development applications, the existing trail along MD Route 193 will be extended.

3. **The City should consider a pedestrian/bicycle connection (bridge over the stream) at the gap in Old Chapel Road, between High Bridge Estates and Prospect Knolls.**

COMMENT: While this area is beyond the City limits, there is some merit to exploring the potential of the installation of a pedestrian/bicycle bridge in this location. A crossing would provide a link between two residential communities. However, the environmental features of the stream crossing and fiscal costs would need to be reviewed. Since this crossing would be within the County, the City should recognize that some type of grants and cost sharing between the two governments would be necessary.

4. **A trail/sidewalk system should be provided along the length of Chestnut Avenue/High Bridge Road, between Huntington and the WB&A Trail, to safely accommodate pedestrians and bicyclists.**

COMMENT: An alternate on-road route for the East Coast Greenway is being considered that would enable users of the WB&A Trail to access the Huntington area via Chestnut Avenue.



5. **Pedestrian/bicycle trail system connections should be investigated along Mitchellville Road in the Pointer Ridge area.**  
COMMENT: This Trails Master Plan recommends the designation of a shared on-road bike route along Peach Walker Drive and Pittsfield Lane, which lead to Mitchellville Road.
6. **Bike lanes should be designated in the shoulders of Atlantis Drive.**  
COMMENT: Atlantis Drive is one of the streets on which a shared on-road bike route is proposed.
7. **Shoulder/bike lanes should be provided along Excalibur Road to enable residents of Pin Oak Village access to the New Town Center and Collington Plaza.**  
COMMENT: An off-road trail exists along the northern side of Excalibur Road to serve this purpose.
8. **To facilitate bicycle traffic between Collington Branch Stream Valley Park and trail, Pointer Ridge Park south and Pointer Ridge Plaza, shoulder/bike lanes should be provided along Pointer Ridge Drive.**  
COMMENT: A shared on-road bike route is proposed on Pointer Ridge Drive to serve this purpose.
9. **To facilitate movement of bicycle traffic in north Pointer Ridge, shoulder/bike lanes should be provided on Peachwalker Drive.**  
COMMENT: An on-road bike route is proposed in this Trails Master Plan along Peachwalker Drive.
10. **Sidewalks and shoulder/bike lanes should be provided along Old Stage Road to provide connections to the Collington Branch, its tributary trails and to the Church Road trail.**  
COMMENT: This Trails Master Plan Map recommends the identification of an on-road shared bike route along Old Stage Road.
11. **Sidewalks and shoulder/bike lanes should be provided along Dunwood Valley Drive to provide safe travel to: Woodmore Park; Prince George's Boys and Girls Club; the PT-1 east/west trail; the Church Road trail, and; the Collington Branch trail.**  
COMMENT: On-road bike routes are recommended in this Trails Master Plan for Dunwood Valley Drive, which would connect with a future off-road within the A-44 right-of-way.

12. **To provide a link to the Collington Branch Stream Valley Trail (via the Princeton Square trail), the shoulders of Kenhill Drive and Stonybrook Drive should be delineated with bike lanes.**

COMMENT: Shared on-road bike routes are recommended in this Trails Master Plan for Kenhill Drive and Stonybrook Drive. These would provide a link to Princeton Square community, the MD Route 197 trail and the commercial uses along MD Route 450.

13. **Shoulder/bike lanes should be provided along Superior Lane to allow bicycle access to Whitemarsh Park (from Spur Way), The Marketplace, Free State Mall and trails along MD Route 450.**

COMMENT: Shared on-road bike routes are proposed in this Trails Master Plan along Superior Lane to provide the link described above.

14. **To help integrate Bowie State University with northeast Bowie and the existing trail system, an on-road bike route, along MD Route 197, from Rustic Hill Drive to the Bowie State University campus and MARC station.**

COMMENT: This Trails Master Plan recommends the link to the WB&A Trail via MD Route 197 since it involves using the wide shoulders that exist along the State highway and would be a safer route than one along Race Track Road, which is narrow.

15. **Right-of-way for A-44 should be placed in reservation as opposed to dedication during review of subdivision applications. Use of this right-of-way for hiker-biker trails as an interim use should be explored in a site-by-site basis.**

COMMENT: This Trails Master Plan recommends the use of A-44 parcels for the alignment of an off-road trail between Mt. Oak Road and Central Avenue (MD Route 214), and continuing between the Collington Station and Collington Manor residential communities.

16. **A hiker-biker trail should be provided for the entire length of MD Route 193.**

COMMENT: The current Area Master Plan recommends an off-road trail along MD Route 193. The initial segment of this trail was installed as part of the Marleigh development.

17. **Hiker-biker and equestrian trail networks should be expanded and interconnected.**

COMMENT: This Trails Master Plan recommends the expansion and interconnection of both of these networks. The expansion of the hiker-biker system is proposed using a combination of off-road and on-road trails. The equestrian trails system is recommended for expansion by providing a multi-

use/equestrian corridor through the City-owned Fladung property to the WB&A Trail, on which equestrians are permitted. A second recommendation with respect to equestrian trails is to expand the off-road/unimproved trail network in the vicinity of the Patuxent River area, north and south of the WB&A Trail.

18. **The City shall create a City-wide trail plan, which shall include trails adjacent to existing City trails, Master Planned trails, and any trails not specifically identified on the Master Plan, yet deemed a desirable logical extensions of existing or planned trails. Use of existing City collector streets shall be given full consideration where possible. Use of City owned parks, drainage easements, and other facilities shall also be included where possible. Priority shall be given to facilitating safe pedestrian and bicycle travel between such high pedestrian/bicycle attractors as schools, parks, shopping areas, existing and planned public buildings such as the library and the future civic auditorium, etc. Lighting should be provided for safety after dark.**

COMMENT: The contents and recommendations of this Trails Master Plan incorporate a majority of the approaches cited above. - The provision of lighting along trails is not recommended for two significant reasons, including: the potential of encouraging trail use after dark and accompanying safety issues; and, the cost of installation, operation and maintenance of such a system.

19. **The City should work toward finding the means, such as the existing pedestrian/bicycle bridge that was actively sought by the City, to minimize the physical separation of residential communities caused by major roadways such as U.S. Route 50, MD Route 214 and MD Route 197.**

COMMENT: This Trails Master Plan recognizes the need to provide a pedestrian/bicycle link between the residential communities on the north and south sides of MD Route 214 (Central Avenue). An earlier/temporary initiative calls for an at-grade crossing at the signalized intersection of Central Avenue/Jennings Mill Drive/Devonwood Drive. A long term/permanent project includes the recommendation of a grade-separated crossing at this intersection. A grade-separated, hiker/biker bridge exists over U.S. Route 50, connecting the central portion of the City. The City has received a grant from the SHA to construct a hiker/biker bridge over MD Route 197 in the Bowie Town Center.

20. **Connections to the Master Plan trails system should be made by a developer where the system abuts the developer's property.**

COMMENT: These connections would be addressed at the time of subdivision or site plan review of a land development proposal. An example of where this practice has occurred is in

the Saddlebrook community, where the developer is required to link the internal trail system to the WB&A Trail.

- 21. Right-of-way for the Inter-County Connector (A-44) should be placed in reservation as opposed to dedication during review of subdivision applications. Use of this right-of-way for hiker-biker trails as an interim use should be explored in a site-by-site basis.**

COMMENT: Although houses exist and others are under construction, in portions of the A-44 alignment, construction of a trail in this right-of-way, and adjacent open spaces owned by homeowners associations, is feasible once the highway designation is removed from the Area Master Plan.

- 22. Interim use of the existing alignment for hiker-biker trails is encouraged where links to major trail systems can be provided to enhance access these systems.**

COMMENT: The following trail extensions are recommended as part of this Master Plan:

- MD Route 197 trail to the WB&A Trail, and continuing to the campus of Bowie State University;
- Trail through the Fladung Property to intersect the WB&A Trail;
- Trail connections from the Hopkins Property, Woodmore Estates, Ashleigh, Tall Oaks Crossing, Devonshire, Grovehurst, Collington Manor and Collington Station communities to a new trail in the A-44 r-o-w.

- 23. A hiker-biker trail should be provided for the entire length of MD Route 193.**

COMMENT: The Area Master Plan indicates the provision of a trail along MD Route 193 (Enterprise Road). Although this state road is more than one mile from the City boundary, a trail was approved and installed as part of the Marleigh residential community, located on the east side of Enterprise Road.

- 24. An eight-foot wide hiker/biker trail shall be located along the entire northern side of MD Route 450 to accommodate non-motorized travel.**

COMMENT: The plans for relocated/widened MD Route 450 include an off-road, 8-foot wide hard surface trail on the north side of the roadway.

25. **Connections to the Master Plan Trails System should be made by a developer where the system abuts the developer's property.**

COMMENT: Examples of this include: the City installing a trail along the frontages of the gymnasium and senior center sites on Health Center Drive that connects to the trail on Northview Drive; and, more than a mile of developer-constructed trails around the perimeter of and pedestrian walkways within the retail component of the Bowie Town Center.

26. **Encourage residential areas to be linked via vehicular and/or pedestrian connections.**

COMMENT: During the review stage of land development applications, the presence of vehicular and pedestrian interconnections is addressed. In the older sections of the City, there is potential for residential areas to be linked via a network of on-road bicycle trails. This Trails Master Plan proposes such a network.

27. **Residential areas should be connected by means of a continuous network of open space, hiker/biker trails and roads intended and designed to link those areas together, as well as link them with recreational and commercial uses.**

COMMENT: The premise of this policy is being re-enforced by the proposals of this Trails Master Plan, which include linking developed areas together via the continued construction of off-road trails and the inclusion of a new on-road system in older areas of the City where off-road trails are not feasible.

28. **Residential areas should be buffered from non-residential uses and activities, while encouraging these areas to be linked via vehicular and/or pedestrian connections.**

COMMENT: This policy has been and will continue to be applied during the review of subdivision and site plan projects.

29. **Segments of sidewalk and trails should be fully interconnected to permit smooth and safe movement between the many schools, parks and recreational facilities.**

COMMENT: A means of achieving this policy is by eliminating any missing links or gaps in the existing pedestrian/cycling system by the extension of sidewalks/trails, as appropriate, and the inclusion of an on-road trails network.

30. **Examples of possible improvements to the overall pedestrian/bicycle system could include the addition of bike lanes on selected streets, such as Stonybrook Drive and Kenhill Drive, to tie together Whitemarsh Park and Allen Pond Park, as well as many public facilities in-between.**

COMMENT: This Trails Master Plan includes the use of Stonybrook Drive, Kenhill Drive and other major drives and

primary residential streets, many of which have been identified herein, for on-road bike routes. Citing streets in this Trails Master Plan for this purpose will result in tying together public places and facilities, thereby achieving the above stated policy.

31. **Improved trails along selected stream beds, such as the one that runs behind Hilltop Plaza and Freestate Mall, the library, high school and St. Pius (actually from Moylan Drive to the Patuxent River) can help provide the needed continuity and improved safety by channeling pedestrian and bike traffic off-road.**

COMMENT: The primary function of streambeds, especially the one cited above, is for stormwater management and flood control. The condition, shape and function of these beds are such that construction of a trail would be a conflicting use, with a potential safety issue, and therefore, inadvisable. However, this is not to say that a bridge structure cannot be constructed across a stream bed to link together adjacent residential, commercial and public uses.

32. **Need Ped/Bike access through the UMSTC to Patuxent River Park along the River.**

COMMENT: This Trails Master Plan proposes a system of off-road and on-road trails to the University of Maryland Science and Tech Center and within Patuxent River Park property.

33. **There appear to be no pedestrian/bicycle provisions for getting to and from the Saddlebrook development to schools, churches and recreational areas along Race Track Road. The WB&A Trail access within Saddlebrook was intended to replace a planned trail along Race Track Road and should be accessible to all parties along this road.**

COMMENT: The Area Master Plan shows an on-road trail along Race Track Road. This Trails Master Plan supports and re-enforces the provision of an on-road trail along Race Track Road, which has been included a listing of potential on-road trails prepared and recommended by the County.

34. **In order to save public funds and make the best use of available land, trails should utilize existing rights-of-way wherever possible, including those of existing roads, water and sewer lines, the Potomac Electric Company, the Baltimore Gas and Electric Company, the abandoned Washington, Baltimore and Annapolis transit line, and PT-1.**

COMMENT: This Trails Master Plan recommends the implementation of this guideline in several ways: the former WB&A transit line has been transformed to the WB&A Trail; on-road bike routes, which will be within the street right-of-way, are recommended throughout the older neighborhoods and residential sections of the City; portions of the A-44 right-of-way are envisioned to expand the off-road trail network; and,

continued discussion with utility companies is encouraged to use their rights-of-way or easements (as the case may be) for trail installation. Since a change of thinking within the County has occurred regarding PT-1, the majority of land set aside for that improvement is no longer available for trails.

### **Design and Technical Standards**

- 1. As the widening of MD Route 214 (Central Avenue) proceeds, the roadway should be monitored for safety impacts to pedestrians/bicyclists.**

**COMMENT:** One feature that addresses this concern is the installation of a traffic signal at the MD Route 214/Devonwood Drive/Jennings Mill Drive intersection. This Trails Master Plan is recommending, as a later initiative, the construction of a grade-separated crossing between the north and south sides of Central Avenue.

- 2. Paved shoulders, with a minimum width of eight feet, should be provided along Race Track Road to serve as bicycle lanes.**

**COMMENT:** As development occurs along Race Track Road, the installation of a shared shoulder/bike route is recommended along the road frontage of project sites. However, at this time, due to the predominance of undeveloped stretches of site frontage along Race Track Road and therefore roadway narrowness (between the Saddlebrook community and MD Route 197), the delineation of an on-road bike facility along this route is inadvisable from a safety perspective.

- 3. Since Church Road is intended to have a trail along its entire length, pursuant to the Area Master Plan, which will be the primary north-south trail west of the Pope Creek's Railroad, the width of the shoulders along this road should be a minimum of six feet.**

**COMMENT:** Church Road is another example of a roadway where many sections, due to its narrowness and horizontal and vertical curves, are not conducive to bicycling. Therefore, from a safety perspective, delineation of an on-road bicycle route is not recommended along its entire length. However, as development occurs in the Church Road corridor, and the pavement surface is widened, an on-road route should be provided.

- 4. A hiker/biker trail provided on at least one side of a major roadway. Designated bicycle lanes should be included on public streets, where such lanes will provide continuity with major hiker-biker trail systems and where it is possible to safely accommodate them. Lanes should be designed as integral engineered features of the street system. A width of five (5) feet for one-way and eight (8) feet for two-way bicycle traffic should be considered the minimum standard.**

COMMENT: Shared on-road bike routes are proposed on more than 30 City streets. These routes are recommended on roads that would safely accommodate the retention of on-street parking, yet provide sufficient area for bicycles. The City streets recommend in this Trails Master Plan for incorporation in the on-road bicycle system currently provide links to community facilities such as parks, schools, playgrounds and open spaces.

5. **The City shall support and, to the extent possible, enforce the Access 2000 guidelines adopted by the State.**

COMMENT: A goal of this Trails Master Plan is compliance with the above guidelines.

6. **Recreational facilities (i.e. tot lots, etc.), and hiker/biker trails and their access points required by an approved detailed site plan or specific design plan, as the case may be, should be completed and useable prior to the issuance of the first Use and Occupancy Permit for the adjacent buildings or residential units the facilities and/or trails are intended to serve.**

COMMENT: The City is following this practice during the build-out of land development projects.

7. **Recreational areas should be connected by means of a continuous network of open space, hiker/biker trails and roads intended and designed to link those areas together, as well as to link them with recreational and commercial uses.**

COMMENT: This Trails Master Plan offers several recommendations for the expansion of both on-road and off-road trails that will address this issue.

8. **The overall non-motorized transportation goal of the City shall be to make it possible for every resident to walk or bike anywhere in the City, safely separated from vehicular traffic with illumination for safety after dark. The City will be a pedestrian friendly community. Generally, all new development will be designed as such.**

COMMENT: While the present trail system throughout the City consists of unlit off-road trails, this Trails Master Plan proposes the development and incorporation of an on-road trail component, which is largely lit by means of existing streetlights. From an economic feasibility standpoint and from a safety perspective, the illumination of current and future off-road trails is not recommended.

9. **Typically, waivers on sidewalks on City streets should only be considered if the project includes a hiker/biker path system connecting to major pedestrian destinations.**



COMMENT: Consideration of sidewalk waivers should be given on a project-by-project basis. Generally, however, sidewalks should be provided in addition to a hiker/biker system.

10. **There should be hiker/biker trail provided on at least one side of a major roadway. Designated bicycle lanes should be included on public streets. A width of five feet for one-way and eight feet for two-way bicycle traffic should be considered the minimum standard.**

COMMENT: A recommendation for on-road (shared roadways), signed bike routes on several City streets is included in this Trails Master Plan. These streets include: Alameda Drive; Aloha Place; Arden Forest Lane; Atlantis Drive; Belair Drive; Buckingham Drive; Chapel Forge Drive; Clearfield Drive; Dunwood Ridge Terrace; Dunwood Valley Drive; Enfield Drive; Everst Drive; Heritage Boulevard; Jenkins Ridge Road; Jennings Mill Drive; Kembridge Drive; Kenhill Drive; Millstream Drive; Moylan Drive; New Haven Drive; Nashua Lane; Old Barn Road; Old Collington Road; Orchard Run (between Race Tack Road and Ox Farm Court); Peach Walker Drive; Perrell Lane; Pittsfield Lane; Pointer Ridge Drive; Rockledge Drive; Rustic Hill Drive; Stonybrook Drive; Superior Lane; Tulip Grove Drive; Whitehall Drive.

While delineated shared parking/on-road bike lanes are not being recommended, the identification, using the appropriate signage, of the above roadways as bike routes, and that they are intended to be shared with bicyclists, will serve the same purpose as if separate lanes were provided.

11. **Maintain strict adherence to the current sidewalk code.**

COMMENT: It is the intention of this Trails Master Plan to maintain adherence to the City sidewalk code.

12. **Enforce strict adherence to the implementation of the Master Plan trail provisions.**

COMMENT: This Trails Master Plan is intended to supplement the trails element and provisions of the County Master Plan, which is in the process of being revised.

13. **Where remaining opportunities exist, bikeways, equestrian and pedestrian trails should be located as far from vehicular traffic as possible.**

COMMENT: Opportunities to achieve this guideline are through the land development review process involving new projects. In many cases, however, where the existing system is primarily able to be expanded and supplemented with on-road trails, compliance with this guideline is more difficult.

14. **The mandatory dedication of lands for recommended trails shall be considered as the situation requires.**

COMMENT: This guideline is addressed through the development review process. Where dedication is not an option, the use of trail easements should be employed to provide for expansion of the trail system.

15. **Trail easements should be provided through the subdivision process with little or no public land acquisition expense.**

COMMENT: This guideline has been and will continue to be applied to land development projects that experience the subdivision review process.

16. **As the local road system is expanded and improved, highway designs should incorporate appropriate clearances, grades and paving to accommodate trails.**

COMMENT: This guideline has been applied to the design of new MD Route 450 and the widening of Mitchellville Road. As other road projects experience the planning process, the City will continue to be an advocate of including trails in the design.

17. **Applications for preliminary subdivision plans should show interior trails and proposed connections with the planned trails system.**

COMMENT: The Saddlebrook development is an example of a residential community with both an internal system of trails and a connection to the regional trail network. (This project will connect to the WB&A Trail via a future bridge.) This Trails Master Plan recommends the connection of the Ashleigh, Devonshire, Tall Oaks Crossing, Westview, Woodmore Estates and Woodmore Highlands communities to a future trail in the A-44 right-of-way. Implementation of the above recommendation will meet the intent of this guideline.

18. **Trails provided privately within subdivisions should be encouraged to connect with the planned trails system.**

COMMENT: The aforementioned subdivisions are examples of communities with trial systems that will connect with the expanding trail system. This is implemented through the development review process.

#### Governmental/Staff Coordination

1. **The City should form a closer working relationship with Anne Arundel County to plan for the completion of the WB&A Trail.**

COMMENT: City staff and active residents of the local biking community developed a working relationship with officials in Anne Arundel County during the construction of the WB&A Trail through Prince George's County. That relationship

continues as efforts are put forth to extent the WB&A Trail across the Patuxent River and into Anne Arundel County.

2. **The City should work with M-NCPPC and County staff to coordinate trail development activities to ensure that gaps are not created at such locations as the stream between Highbridge Estates and Prospect Knolls (Transportation Planning Task Force).**

COMMENT: City staff has been working with M-NCPPC and other County staffs to update the Countywide Trails Plan. A focus of this coordination is to prevent situations such as the one described above.

3. **The City shall monitor all development activity within the City's Planning Area to ensure that Master Planned trails will be provided in pace with development.**

COMMENT: The City has historically monitored and reviewed land development proposals in the Bowie-Collington-Mitchellville Planning Area in regard to the provision of trails.

4. **Establish a program for maintenance of the hiker/biker trails throughout the City, which identifies the trails to be maintained in current and future fiscal years.**

COMMENT: This Trails Master Plan includes such a recommendation.

5. **The City should work with M-NCPPC and County staff to coordinate the development of trail activities to ensure that gaps are not created.**

COMMENT: The City has been and will continue to work with the staffs of the M-NCPPC and Prince George's County to explore and coordinate trail projects.

6. **A program should be established for the maintenance of the hiker/biker trails throughout the City, which identifies the trails to be maintained in current and future fiscal years.**

COMMENT: The past several approved City budgets have included funds for the maintenance and expansion of the City's trail system. This Trails Master Plan recommends the adoption of a trails maintenance program similar to that used by the City's Department of Public Works to resurface City streets.

7. **Since most of Bowie's interior and perimeter greenways and parks are owned and managed by the Park and Planning Commission, the City should monitor any proposed changes in the Commission's operations and plan accordingly to protect it's interests. Additional citizen involvement is strongly encouraged.**

COMMENT: The City is a member of the County's Bicycle and Trails Advisory Group (BTAG) and has been working with this organization, M-NCPPC staff and County Parks Department

staff to update the Countywide Trails Plan. Consequently, the City is participating in and monitoring changes to the proposed County Plan that would impact the City.

### User Groups

1. **The MD Route 450 railroad bridge over the Pope's Creek line should be rebuilt for pedestrians.**

COMMENT: This bridge is intended to be reconstructed and would include an area for pedestrians and bicyclists.

2. **Pedestrian access should be established between the City proper and such locations as Bowie State University and the University of Maryland Science and Technology Center.**

COMMENT: This Trails Master Plan recommends non-vehicular connections to both of the above destinations by on-road linkages along MD Route 197 and Belair Drive.

3. **The future trail on the WB&A r-o-w should be protected from incompatible uses.**

COMMENT: This Trails Master Plan recommends that service areas for trail users be provided in two locations (one of which is an alternate location) along the existing WB&A Trail: at the eastern trail head adjacent to the Patuxent River; or, on land owned by the Park and Planning Commission adjacent to the Nazario Woods subdivision.

4. **Pedestrian access should be provided to all commercial districts and other major pedestrian attractors such as schools, parks and other public facilities.**

COMMENT: An extensive network of existing trails and sidewalks provides pedestrian and bicycle access to the various types of destinations noted above.

5. **Hiker/biker and equestrian trail networks should be expanded and interconnected.**

COMMENT: One of the goals and objectives of this Trails Master Plan is to include recommendations that provide for the expansion and interconnection of the City's trail system.

6. **A system of trails and walks for pedestrians, bicyclists and equestrians should be developed to connect neighborhoods, recreation areas, commercial areas, employment areas, and transportation facilities.**

COMMENT: A goal of this Trails Master Plan is to expand our existing trail system to achieve connection between the various types of areas noted above. The difficult need to address is that of equestrians. However, equestrians are permitted on the WB&A Trail and presently ride in the following areas along informal routes: Duckettstown Road area; Huntington; Tanglewood Park; Bowie State University; and, east of U.S.

Route 301, between Governor Bridge Road and Queen Anne Bridge Road.

#### **D. City Programs**

To continue improving the City's trail and bike route facilities, recommendations are offered in the following programs:

##### **1. Trail Markers Installation and Identification Program**

**RECOMMENDATION:** To provide a responsive locational mechanism for public safety, equipment repairs or medical emergencies, implementation of a trail identifying system is recommended. Establishment of a trail markers identification program should include but not be limited to the following:

- Developing a trail coordinate system that is compatible with that used Countywide;
- Identifying public trails by a color system (i.e., painting colored bands on the markers along various public trails throughout the City to establish a naming system for each trail); and,
- Identifying HOA trails by community name.

##### **2. Bike Rack Installation Program**

**RECOMMENDATION:** To encourage the use of bicycles as an alternative to motor vehicles for non-recreational trips, potential future locations for the continued installation of bike racks include: commercial/retail centers; fast-food and non-fast-food restaurants; office buildings; public uses and buildings; public transit points; and, parks. It is recommended that staff continue to work with business owners and property managers for installation of bike racks within their respective projects and to recommend the provision of bike racks in new commercial developments and public properties and uses.

##### **3. City's Annual Trail Maintenance and Expansion Program**

**RECOMMENDATION:** As the City's trail system continues to age, yet, at the same time is continuously expanding, consideration should continue to be given to maintaining adequate funds allocated in the City CIP for trail maintenance.

A program should also be established whereby funds are set-aside annually in the City's budget for the maintenance and reconstruction of specific trails. (This program would be similar to that used by the Department of Public Works for street resurfacing.)

To continue to improve the quality and aesthetics of the City's trail system, the efforts of service clubs, scout troops, civic clubs, church groups, homeowners associations and other community organizations should continue to be pursued. Consideration should also be given to establishing an "Adopt-a-Trail" program, similar to that which exists for public roads, using the support of the aforementioned groups. Further, the pursuit of grants from outside agencies will continue to be explored for source of assistance.

#### 4. Other Programs to Reduce Bicycle Hazards

The implementation of three other programs are recommended for the purpose of reducing hazards to bicyclists:

- (i) Bicycle-Safe Drainage Grates. Along City streets that have been designated as shared/on-road bikeways, bicycle-safe grates over stormwater drainage inlets should be provided, where necessary. This means eliminating parallel bar grates and replacing them with drainage grates with perpendicular bars (Attachment 11). This technique should also be performed along County roads and State highways.
- (ii) Railroad Track Crossings. Where shared road/bike trails cross railroad tracks, the crossing for bicycles should ideally be at a right angle to the trail rails. In locations where this is not possible, a widened roadway, shoulder or bike lane should be constructed to allow bikes to cross at a right angle to the railroad tracks. This technique involves increasing the width of pavement at crossings between six and eight feet, depending on the amount of right-of-way available, to allow a right angle approach (Attachment 12). Streets where this crossing technique could be used include the railroad crossings at: Mt. Oak Road; Old Chapel Road; Hall Road; and, High Bridge Road. Since these are roads maintained by Prince George's County, it is recommended that the City work with the County Department of Public Works and Transportation so that this crossing technique is provided when these roads are improved.
- (iii) Transition Areas. To identify abrupt changes in the pavement width of a shoulder or bike lane on a shared road, the installation of signage and the use of zebra warning striping on shoulders are recommended (Attachment 13). These techniques serve to shift vehicles away from the shoulder area, thereby providing additional space along the edge of the roadway for safer bicycle operation. Potential locations where these techniques could be used include: Governor Bridge

Road; Mitchellville Road; Mt. Oak Road; Old Chapel Road; and, Race Track Road.

5. **Staff Coordination**

As the City's trails system continues to expand and as more residents take advantage of the opportunities this system provides, continued planning and maintenance of our trail network needs to become an ongoing function.

**RECOMMENDATION:** Establishing a comprehensive trail program requires the involvement, coordination and cooperation of several City departments. The designation of a staff person in one department is essential to provide a coordinating function between the Trails Advisory Committee, City departments, other City staff, other City committees, the general public and the staffs of other governmental agencies.

The commitment of the City Council for an improved, well maintained and expanding trail system has been reflected in the City's adopted CIP in recent years. The Council has approved funds for trail annual maintenance, been supportive for the creation of a public-private partnership for the pedestrian bridge over MD Route 197 and has recognized the importance of endorsing City applications for Trial Town USA and Bicycle Friendly Community designations.

6. **Community Information Display Boards**

**RECOMMENDATION:** To promote trail and bicycle related events, news and information, to inform the public of trail rules and bicycle safety information, display boards are recommended in the following locations:

- Allen Pond Park;
- City of Bowie Gymnasium;
- City of Bowie Dog Park;
- Fladung Property (in conjunction with the construction of the trail proposed for that site);
- Glen Allen Trail System (Black Sox Park);
- Old Collington Road Trail (at Northview Drive intersection);
- Whitmarsh Park (one at each of the three trail entrances [MD Route 450, Spur Way and Whitmarsh Park]); and,

- At the three M-NCPPC Community Centers.

7. **City of Bowie Website**

**RECOMMENDATION:** To complement the news, information and maps displayed on the Community Information Display Boards suggested above, it is recommended that trails information be dispersed via the City's website. Using this communications vehicle would be an asset that would quickly and continuously provide the latest trails information to visitors to the City's website.

8. **City Designations and Support**

(i) **Trail Town USA Designation**

In 1996 the City was selected as a charter member of the Trail Town USA Hall of Fame sponsored by the American Hiking Society. Nearly 100 cities and municipalities were nominated for this award, with the top 30 becoming the first inductees. To achieve this designation, several criteria had to be satisfied and numerous letters in support of the City's nomination had to be filed. In receiving a Trail Town USA award, the American Hiking Society was seeking nominations that went beyond using trails for purely recreational purposes; they were looking for areas where trails promote non-motorized transportation, connect to other trail systems, add to the continuing effort to create a nationwide trail system, bring an added economic benefit to the area and future development plans. Every five years or so, the American Hiking Society intends to revisit the progress of inductees on maintaining their Trail Town USA status and ongoing trail efforts.

**RECOMMENDATION:** It is recommended that to maintain our designation as a Trail Town USA, the City continue its efforts to:

- Expand and maintain its trail system;
- Install bike racks and trail markers;
- Promote trail and bicycle related events; and,
- Distribute trail maps and other related information.



(ii) **Bicycle Friendly Community (Attachment 14)**

In addition to being designated as Trail Town USA, the City has also received an award as being a Bicycle Friendly Community by the American League of Bicyclists.

**RECOMMENDATION:** This Trails Master Plan recommends that the City continue in its efforts to maintain its designation as a Bicycle Friendly Community.

(iii) **Walkable Cities Program**

**RECOMMENDATION:** Upon the completion and adoption of this Trails Master Plan, staff will pursue participation in the Walkable Cities Program.

## **APPENDIX I**

### **Definitions**

**BICYCLE**—Every vehicle propelled solely by human power upon which any person may ride, having two tandem wheels, except scooters and similar devices. The term “bicycle” also includes three- and four-wheeled human-powered vehicles, but not tricycles for children.

**BICYCLE FACILITIES**—A general term denoting improvements and provisions made by public agencies to accommodate or encourage bicycling, including parking and storage facilities, and shared roadways not specifically designated for bicycle use.

**BICYCLE LANE or BIKE LANE**—A portion of a roadway which has been designated by striping, signing and pavement markings for the preferential or exclusive use of bicyclists.

**BICYCLE PATH or BIKE PATH**—See Shared Use Path.

**BICYCLE ROUTE SYSTEM**—A system of bikeways designated by the jurisdiction having authority with appropriate directional and informational route markers, with or without specific bicycle route numbers. Bike routes should establish a continuous routing, but may be a combination of any and all types of bikeways.

**BIKEWAY**—A generic term for any road, street, path or way which in some manner is specifically designated for bicycle travel, regardless of whether such facilities are designated for the exclusive use of bicycles or are to be shared with other transportation modes.

**HIGHWAY**—A general term denoting a public way for purposes of vehicular travel, including the entire area within the right-of-way.

**RAIL-TRAIL**—A shared use path, either paved or unpaved, built within the right-of-way of an existing or former railroad.

**RIGHT-OF-WAY**—A general term denoting land, property or interest therein, usually in a strip, acquired for or devoted to transportation purposes.

**RIGHT OF WAY**—The right of one vehicle or pedestrian to proceed in a lawful manner in preference to another vehicle or pedestrian.

**ROADWAY**—The portion of the highway, including shoulders, intended for vehicular use.

**RUMBLE STRIPS**—A textured or grooved pavement sometimes used on or along shoulders of highways to alert motorists who stray onto the shoulder.

**SHARED ROADWAY**—A roadway that is open to both bicycle and motor vehicle travel. This may be an existing roadway, street with wide curb lanes, or road with paved shoulders.

**SHARED USE PATH**—A bikeway physically separated from motorized vehicular traffic by an open space or barrier and either within the highway right-of-way or within an independent right-of-way. Shared use paths may also be used by pedestrians, skaters, wheelchair users, joggers and other non-motorized users.

**SHOULDER**—The portion of the roadway contiguous with the traveled way for accommodation of stopped vehicles, for emergency use and for lateral support of sub-base, base and surface courses.

**SIDEWALK**—The portion of a street or highway right-of-way designed for preferential or exclusive use by pedestrians.

**SIGNED SHARED ROADWAY (SIGNED BIKE ROUTE)**—A shared roadway which has been designated by signing as a preferred route for bicycle use.

**TRAVELED WAY**—The portion of the roadway for the movement of vehicles, exclusive of shoulders.

**UNPAVED PATH**—Paths not surfaced with asphalt or Portland cement concrete.

## APPENDIX II

### Trail Rules

Adoption of rules of the trails is essential to help ensure the safety of trail users, minimize conflicts among those users and conflicts between the users and the natural environment. These rules should be posted at key access point to major trails throughout the City and should include, but not be limited to the following:

- The trail is only open during daylight hours.
- Alcoholic beverages are prohibited.
- Pedestrians and person with disabilities always have the right of way.
- Bicyclists shall wear helmets at all times when riding and are required to obey all traffic controls and signals.
- No bicycling or roller skate/blade racing shall be permitted on the trail.
- Cyclists and skaters/bladers shall give an audible warning passing other trail users.
- Unauthorized motor vehicles shall not be permitted on the trail.
- Pets must be kept on a leash a maximum of 6 feet in length and under control at all times.

## LIST OF RESOURCES

Bicycle Facility Planning, Planning Advisory Service Report No. 459, American Planning Association. Suzan Anderson Pinsof and Terri Musser, October 1995.

Bowie-Collington-Mitchellville and Vicinity Master Plan, April 1991. The Maryland-National Capital Park and Planning Commission.

City of Bowie Recreation Master Plan, 1996-2005, Community Recreation Committee. Adopted February 1999.

Guide for the Development of Bicycle Facilities, American Association of State Highway and Transportation Officials, 1999.

Trails and Greenways, Volume 32/Number 4, April 2000. IQ Service Report.





# City of Bowie Trails Master Plan

Adopted by The Bowie City Council on May 20, 2002

Attachment 1





## Legend

-  City of Bowie
-  Property Lines







1 inch equals 4,000 feet

- Data Sources: MNCPPC & The City of Bowie.
- Prepared by The City of Bowie Information Technology Department.
- All data is offered as is and without any actual or implied warranty as to accuracy.
- Created January, 2003
- c:\gisstuff\arcmap\_projects\trailsmasterplan11x17(II).mxd

## Existing Trails Public & Home Owners Association (HOA)

-  Equestrian Trails - 5.46 Miles
-  Off-Road Trails - 32.26 Miles
-  Existing HOA Trails - 9.82 Miles
-  Service/Rest Area

## Proposed Trails Public & Home Owners Association (HOA)

-  Water Trails - 6.54 Miles
-  On-Road Bikeways - 54.72 Miles
-  Off-Road Trails - 36.72 Miles
-  Equestrian Trails - 10.64 Miles
-  Proposed HOA Trails - 2.17 Miles
-  Service/Rest Area

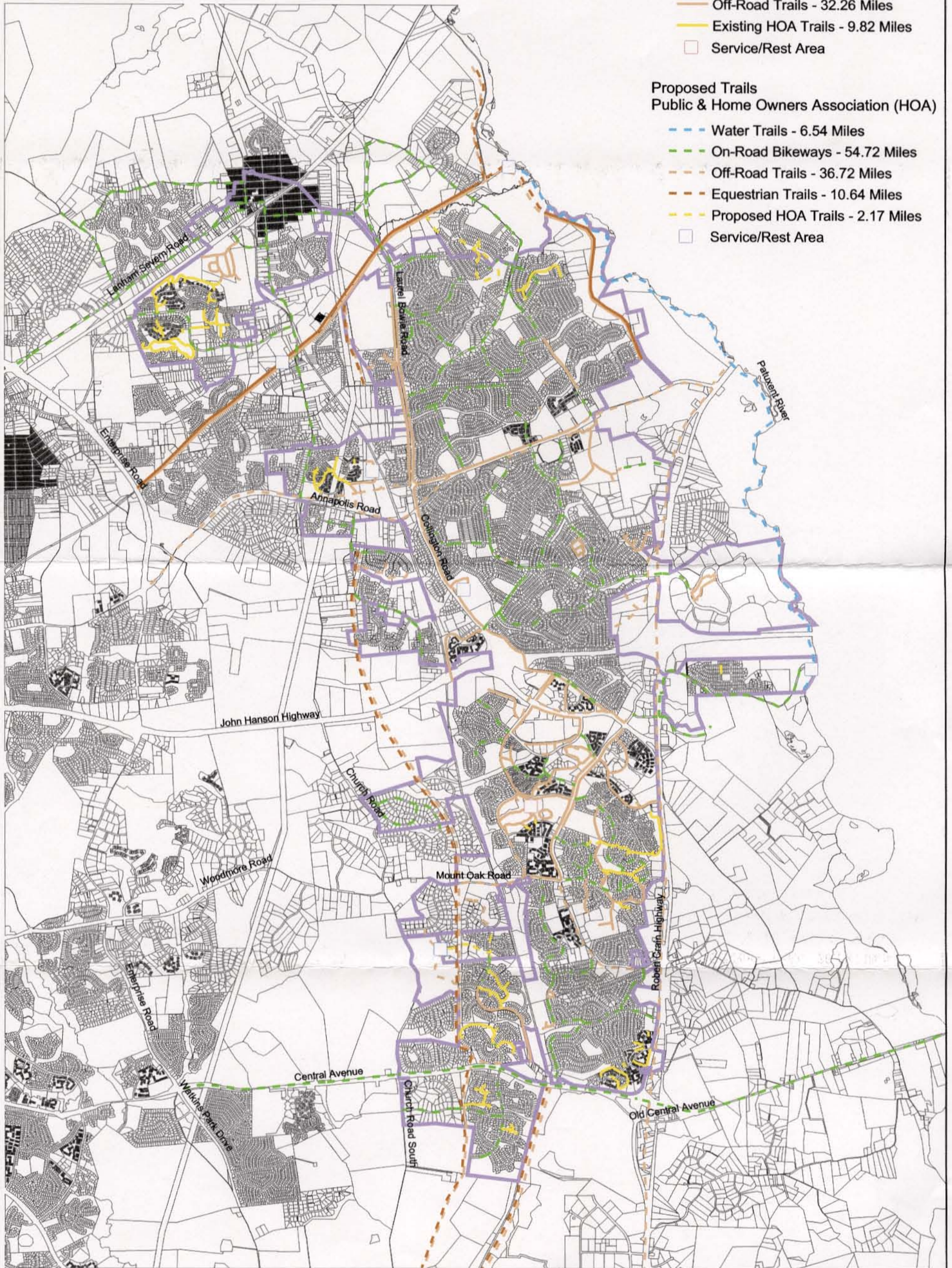



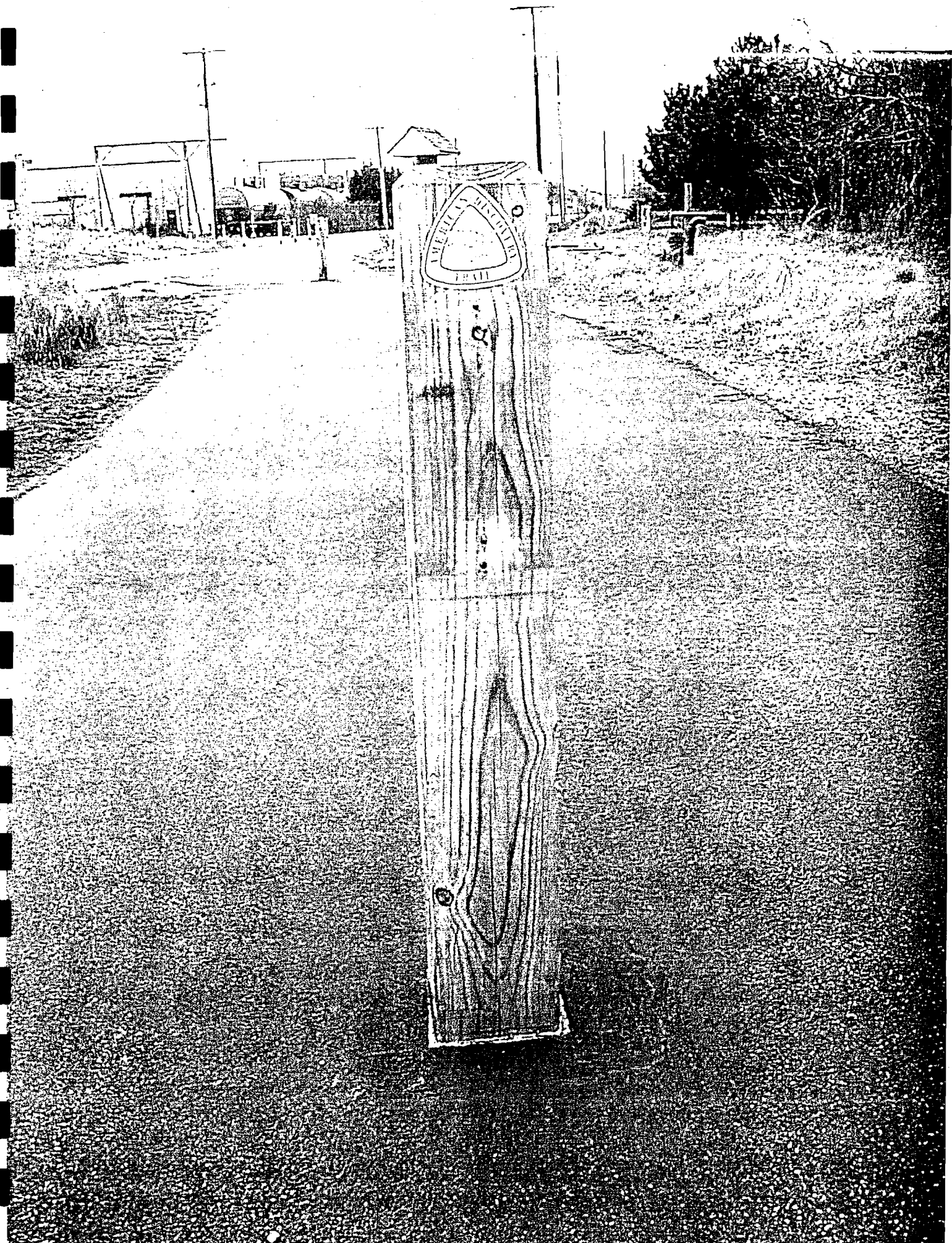











SHARE  
THE  
ROAD



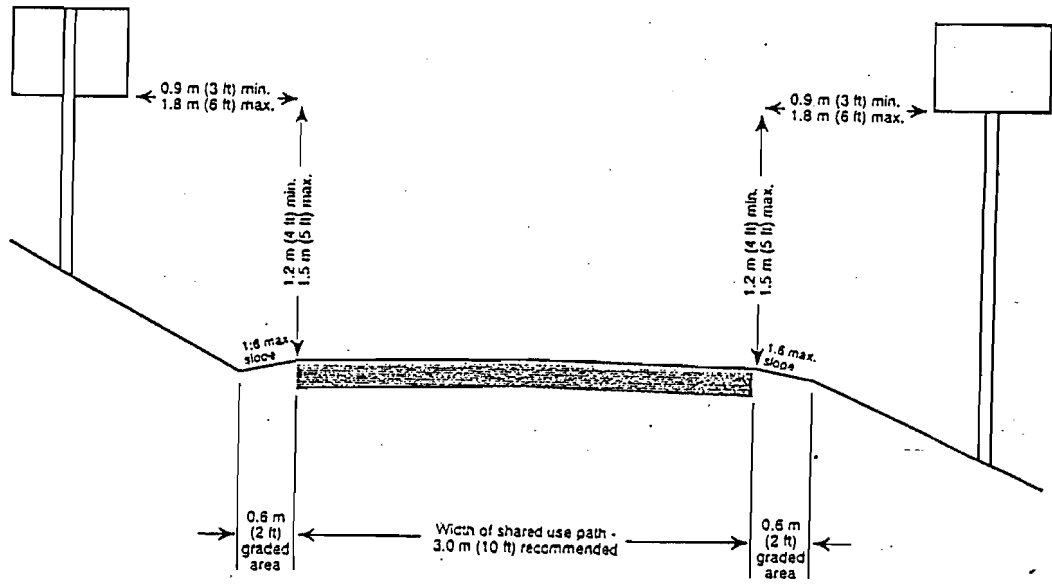

Cross Section of Two-Way Shared Use Path on Separated Right-of-Way

### Equestrian Trail Typical Clearing

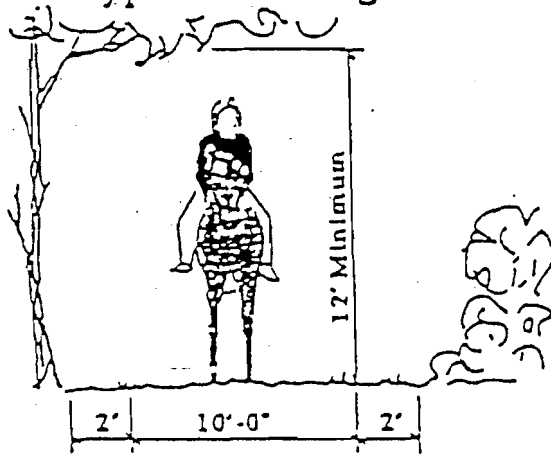

**NOTE**

1. REMOVE ALL LIMBS AND BRANCHES TO 12'
2. PROVIDE POSITIVE DRAINAGE AWAY FROM PATH.

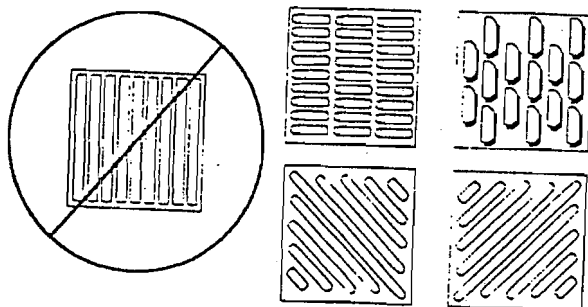

DRAINAGE GRATES



SKEWED RAILROAD CROSSING TREATMENT

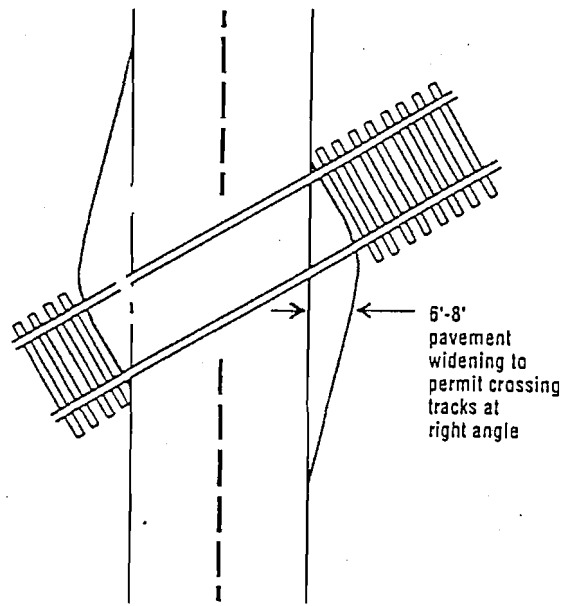

WARNING STRIPING ON  
NARROW BRIDGE SHOULDERS

