

A STRUCTURE THEOREM FOR $RO(C_2)$ -GRADED COHOMOLOGY

by

CLOVER MAY

A DISSERTATION

Presented to the Department of Mathematics
and the Graduate School of the University of Oregon
in partial fulfillment of the requirements
for the degree of
Doctor of Philosophy

June 2018

DISSERTATION APPROVAL PAGE

Student: Clover May

Title: A Structure Theorem for $RO(C_2)$ -graded Cohomology

This dissertation has been accepted and approved in partial fulfillment of the requirements for the Doctor of Philosophy degree in the Department of Mathematics by:

Dr. Daniel Dugger	Chair
Dr. Boris Botvinnik	Core Member
Dr. Hal Sadofsky	Core Member
Dr. Benjamin Young	Core Member
Dr. Stephanie Majewski	Institutional Representative

and

Dr. Sara D. Hodges	Interim Vice Provost and Dean of the Graduate School
--------------------	---

Original approval signatures are on file with the University of Oregon Graduate School.

Degree awarded June 2018

© 2018 Clover May

DISSERTATION ABSTRACT

Clover May

Doctor of Philosophy

Department of Mathematics

June 2018

Title: A Structure Theorem for $RO(C_2)$ -graded Cohomology

Let C_2 be the cyclic group of order two. We present a structure theorem for the $RO(C_2)$ -graded Bredon cohomology of C_2 -spaces using coefficients in the constant Mackey functor $\underline{\mathbb{F}}_2$. We show that, as a module over the cohomology of the point, the $RO(C_2)$ -graded cohomology of a finite C_2 -CW complex decomposes as a direct sum of two basic pieces: shifted copies of the cohomology of a point and shifted copies of the cohomologies of spheres with the antipodal action. The shifts are by elements of $RO(C_2)$ corresponding to actual (i.e. non-virtual) C_2 -representations.

CURRICULUM VITAE

NAME OF AUTHOR: Clover May

GRADUATE AND UNDERGRADUATE SCHOOLS ATTENDED:

University of Oregon, Eugene, OR
North Carolina State University, Raleigh, NC
University of Massachusetts Boston, Boston, MA

DEGREES AWARDED:

Doctor of Philosophy, Mathematics, 2018, University of Oregon
Master of Science, Mathematics, 2015, University of Oregon
Post Baccalaureate Certificate, 2012, North Carolina State University
Bachelor of Arts, Mathematics, 2011, University of Massachusetts Boston
Bachelor of Arts, Sociology, 2006, University of Massachusetts Boston

AREAS OF SPECIAL INTEREST:

Algebraic Topology
Equivariant Homotopy Theory

PROFESSIONAL EXPERIENCE:

Graduate Teaching Fellow, University of Oregon, Eugene, 2012–2018

GRANTS, AWARDS AND HONORS:

Anderson Distinguished Graduate Teaching Award, University of Oregon
Department of Mathematics, 2017

Paul and Harriet Civin Memorial Graduate Award, University of Oregon
Department of Mathematics, 2012

Juan Carlos Merlo Prize, University of Massachusetts Boston
Department of Mathematics, 2016

ACKNOWLEDGEMENTS

I would like to thank Dan for his guidance and patience. I am grateful to Eric for many helpful conversations throughout graduate school. Finally, I would like to thank Andy and Arly for their support and encouragement.

TABLE OF CONTENTS

Chapter	Page
I. INTRODUCTION	1
1.1. Proof Sketch	2
1.2. Organization	3
II. PRELIMINARIES	4
2.1. Cohomology of a Point	7
2.2. Cohomology of the Antipodal Sphere	8
III. COMPUTATIONAL TOOLS	10
IV. GRADED MODULES AND COHOMOLOGY	13
4.1. Toda Brackets	15
V. MAIN THEOREM	26
VI. APPLICATIONS	31
6.1. Computational Applications	31

Chapter	Page
6.2. Homology	37
6.3. Borel Cohomology	38
APPENDICES	
A. INJECTIVITY	40
B. MOTIVATION	47
REFERENCES CITED	49

LIST OF FIGURES

Figure	Page
2.1	Some low dimensional representation spheres. 6
2.2	$\mathbb{M}_2 = H^{*,*}(pt)$ 7
2.3	$\mathbb{A}_n = H^{*,*}(S^n_a)$ 8
4.1	Hidden τ extension in $\tilde{H}^{*,*}(C_{2+} \wedge S^2)$ 19
4.2	Vanishing regions and region containing \mathbb{M}_2 generators. 22
5.1	Cohomology of $S^{\infty, \infty}$ 29
6.1	$\mathbb{R}P^2_{tw}$ 32
6.2	Differential in a long exact sequence for $\tilde{H}^{*,*}(\mathbb{R}P^2_{tw})$ 33
6.3	Cohomology of $\mathbb{R}P^2_{tw}$ 34
6.4	Differential to upper cone of \mathbb{M}_2 35
6.5	Another differential to an upper cone of \mathbb{M}_2 36
6.6	Differential to \mathbb{A}_0 37
A.1	Some ideals in \mathbb{M}_2 40
B.1	Cohomology of C_2 -actions on a torus. 48

CHAPTER I

INTRODUCTION

For $RO(C_2)$ -graded Bredon cohomology, working with coefficients in the constant Mackey functor $\underline{\mathbb{F}}_2$ is the closest analogue to using \mathbb{F}_2 coefficients for singular cohomology. One might expect computations to be fairly straightforward in this setting, as they are in singular cohomology. Unfortunately, these computations are often nontrivial even for simple C_2 -spaces. The goal of this paper is to give a structure theorem for the $RO(C_2)$ -graded cohomology of finite C_2 -CW complexes with coefficients in $\underline{\mathbb{F}}_2$. This structure theorem can be used to make computations easier.

Let \mathbb{M}_2 denote the $RO(C_2)$ -graded cohomology of a point. Let \mathbb{A}_n denote the cohomology of the n -dimensional sphere with the antipodal action. We will show that if X is a finite C_2 -CW complex, then its cohomology contains only shifted copies of \mathbb{M}_2 and shifted copies of \mathbb{A}_n for various n . A bit more precisely, as an \mathbb{M}_2 -module we can decompose the cohomology of X as

$$H^{*,*}(X; \underline{\mathbb{F}}_2) \cong (\oplus_i \Sigma^{p_i, q_i} \mathbb{M}_2) \oplus (\oplus_j \Sigma^{r_j, 0} \mathbb{A}_{n_j})$$

for some dimensions n_j and bidegrees (p_i, q_i) and $(r_j, 0)$ that correspond to actual (i.e. non-virtual) C_2 -representations.

Each copy of $\Sigma^{p_i, q_i} \mathbb{M}_2$ is the reduced cohomology of a representation sphere S^{p_i, q_i} . So in some sense the structure theorem means the cohomology of any finite C_2 -CW complex looks like cohomologies of representations spheres and suspensions of antipodal spheres. At first glance, this might appear obvious because spheres are

the building blocks for CW-complexes. However, we will see it is actually rather surprising that we only need these two types of objects to describe $RO(C_2)$ -graded cohomology in \mathbb{F}_2 coefficients. The analogous statement for singular cohomology in \mathbb{F}_2 coefficients is trivial because the coefficient ring \mathbb{F}_2 is a field. But the coefficient ring \mathbb{M}_2 is not a field and there are many \mathbb{M}_2 -modules that do not appear as the cohomology of space. Even the modules that arise in computations as kernels and cokernels of differentials are typically more complicated than simply shifted copies of \mathbb{M}_2 and \mathbb{A}_n .

1.1. Proof Sketch

We briefly outline the proof from Chapter V as a guide for the reader. The ring \mathbb{M}_2 is infinite but can be described in terms of particular elements ρ, τ , and θ . The ring \mathbb{A}_n is isomorphic to $\mathbb{F}_2[\tau, \tau^{-1}, \rho]/(\rho^{n+1})$. Let X be a finite C_2 -CW complex. The proof that its cohomology contains only shifted copies of \mathbb{M}_2 and shifted copies of \mathbb{A}_n begins by showing that copies of \mathbb{M}_2 in $H^{*,*}(X)$ are easily detected by θ . Accounting for each copy of \mathbb{M}_2 , we will obtain a short exact sequence of the form

$$0 \rightarrow \bigoplus_i \Sigma^{p_i, q_i} \mathbb{M}_2 \rightarrow H^{*,*}(X) \rightarrow Q \rightarrow 0,$$

which splits because \mathbb{M}_2 is self-injective. Finally, we will show $Q \cong \bigoplus_j \Sigma^{r_j, 0} \mathbb{A}_{n_j}$. This will follow from a result about the ρ -localization of $H^{*,*}(X)$ together with a rather surprising higher decomposition of 1 in \mathbb{M}_2 . The higher decomposition of 1 is given by the Toda bracket $\langle \tau, \theta, \rho \rangle = 1$, which was first suggested by Dan Isaksen. We will use ρ -localization and the Toda bracket to show Q is a finitely generated

$\mathbb{F}_2[\tau, \tau^{-1}, \rho]$ -module, i.e. Q is a module over a graded PID. The graded analogue of the classification of finitely generated modules over a PID completes the proof.

1.2. Organization

In Chapters II and III we provide some of the required background and set some notation and terminology. Much of this can be found in [7] and [8]. Chapter IV includes several important facts about \mathbb{M}_2 -modules and their implications for the cohomology of C_2 -spaces. This chapter also includes the computation of the nontrivial Toda bracket of 1 in \mathbb{M}_2 mentioned above. In Chapter V we prove the main theorem. Chapter VI demonstrates some applications of the main theorem for computations. Appendix A is devoted to the proof of a technical proposition from Chapter IV. Appendix B presents calculations of cohomology for the six C_2 -actions on a torus, which provided some of the motivation for the structure theorem.

CHAPTER II

PRELIMINARIES

We begin with some terminology and notation, much of which appears in [7] and [8]. Let G be a finite group.

Definition 2.0.1. *A **G -CW complex** is a G -space X with a filtration, where X_0 is a disjoint union of orbits G/H and X_n is obtained from X_{n-1} by attaching cells of the form $G/H_\alpha \times D^n$ along equivariant maps $f_\alpha : G/H_\alpha \times S^{n-1} \rightarrow X_{n-1}$. The cells are attached via the usual pushout diagram*

$$\begin{array}{ccc} \coprod_\alpha G/H_\alpha \times S^{n-1} & \longrightarrow & X_{n-1} \\ \downarrow & & \downarrow \\ \coprod_\alpha G/H_\alpha \times D^n & \longrightarrow & X_n \end{array}$$

where D^n and S^{n-1} have the trivial G -action.

The space X_n is the **n -skeleton** of X and the filtration gives a cell structure for X . If the filtration is finite, X is a **finite-dimensional G -CW complex** and the highest dimension in the filtration is the **dimension of X** . If there are finitely many cells of each dimension, X is referred to as **locally finite**. When X is both finite-dimensional and locally finite, we call X a **finite G -CW complex**. The filtration quotients for X are of the form $X_n/X_{n-1} \cong \bigvee_\alpha G/H_{\alpha+} \wedge S^n$.

One reason we study G -CW complexes is that every CW complex with a cellular G -action can be given a filtration with the structure of a G -CW complex (see [8]). It is often convenient to work with **pointed G -CW complexes**, meaning G -CW complexes with a fixed basepoint. If X is a G -CW complex, we may always consider the based space X_+ , i.e. X with a disjoint basepoint that is fixed by the action.

We now specialize to the case $G = C_2$, the cyclic group of order two. Although some facts presented here generalize to other groups and other types of spaces, we restrict our focus to C_2 -CW complexes. The coefficients for the $RO(G)$ -graded cohomology of a G -space are given by a Mackey functor. The data of a Mackey functor for $G = C_2$ is encoded in a diagram of the form

$$M : \begin{array}{ccc} & \begin{array}{c} \textcircled{t} \\ \downarrow \end{array} & \\ & M(C_2) & \begin{array}{c} \xrightarrow{p_*} \\ \xleftarrow{p^*} \end{array} & M(pt) \end{array}$$

where $C_2/e = C_2$ and $C_2/C_2 = pt$ are the two orbits and $M(C_2)$ and $M(pt)$ are abelian groups. The maps must satisfy the following conditions:

1. $t^2 = id$,
2. $tp^* = p^*$,
3. $p_*t = p_*$, and
4. $p^*p_* = id + t$.

We will be using coefficients in $\underline{\mathbb{F}}_2$, the constant Mackey functor with value \mathbb{F}_2 , which has the diagram

$$\underline{\mathbb{F}}_2 : \begin{array}{ccc} & \begin{array}{c} \textcircled{id} \\ \downarrow \end{array} & \\ & \mathbb{F}_2 & \begin{array}{c} \xrightarrow{0} \\ \xleftarrow{id} \end{array} & \mathbb{F}_2. \end{array}$$

A p -dimensional real C_2 -representation V decomposes as

$$V \cong (\mathbb{R}^{1,0})^{p-q} \oplus (\mathbb{R}^{1,1})^q = \mathbb{R}^{p,q}$$

where $\mathbb{R}^{1,0}$ is the trivial 1-dimensional real representation of C_2 and $\mathbb{R}^{1,1}$ is the sign representation. We call p the **topological dimension** and q the **weight** or

twisted dimension of $V = \mathbb{R}^{p,q}$. We will also refer to the **fixed-set dimension**, which is $p - q$. We use this same notation and terminology when V is a virtual representation given by $V = \mathbb{R}^{p_1,q_1} - \mathbb{R}^{p_2,q_2}$, in which case we say that V has topological dimension $p_1 - p_2$, weight $q_1 - q_2$, and fixed-set dimension $(p_1 - q_1) - (p_2 - q_2)$. If $V = \mathbb{R}^{p,q}$ is an actual representation, we write $S^V = S^{p,q}$ for the **representation sphere** given by the one-point compactification of V . Again, we use this same notation when V is a virtual representation and we are working stably.

Figure 2.1 shows depictions of some low dimensional representation spheres. Here $S^{1,1}$ and $S^{2,1}$ have the C_2 -action given by reflection across an equator and $S^{2,2}$ has the C_2 -action given by rotation about the axis through the north and south poles.

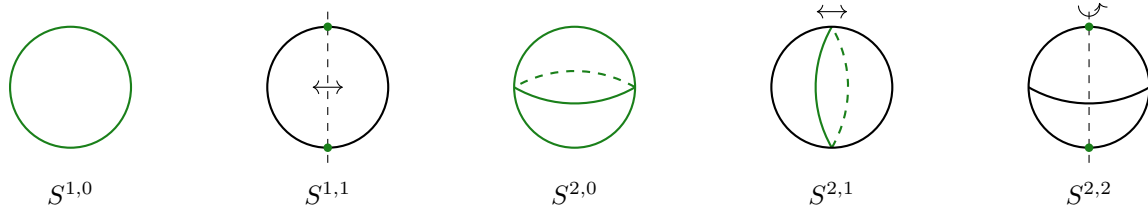

FIGURE 2.1 Some low dimensional representation spheres.

For any virtual representation $V = \mathbb{R}^{p,q}$, allowing p and q to be integers, we write $H_G^V(X; M) = H^{p,q}(X; M)$ for the V th graded component of the ordinary $RO(C_2)$ -graded equivariant cohomology of a C_2 -space X with coefficients in a Mackey functor M . For a based C_2 -space we write $\tilde{H}^{*,*}(X; M)$ for the reduced cohomology of X . If we give X a disjoint basepoint then $\tilde{H}^{*,*}(X_+; M) = H^{*,*}(X; M)$. For the rest of the paper we will use coefficients in the constant Mackey functor $\underline{\mathbb{F}}_2$ so we usually suppress the coefficients and write $H^{*,*}(X)$ for $H^{*,*}(X; \underline{\mathbb{F}}_2)$. When we work non-equivariantly, we write $H_{sing}^*(X)$ for the singular

cohomology with \mathbb{F}_2 -coefficients of the underlying topological space $U(X)$, where U is the forgetful functor.

2.1. Cohomology of a Point

Using coefficients in the constant Mackey functor $\underline{\mathbb{F}}_2$, the cohomology of a point with the trivial C_2 -action is the ring $\mathbb{M}_2 := H^{*,*}(pt; \underline{\mathbb{F}}_2)$ pictured in Figure 2.2. On the left is a more detailed depiction, though in practice it is easier to work

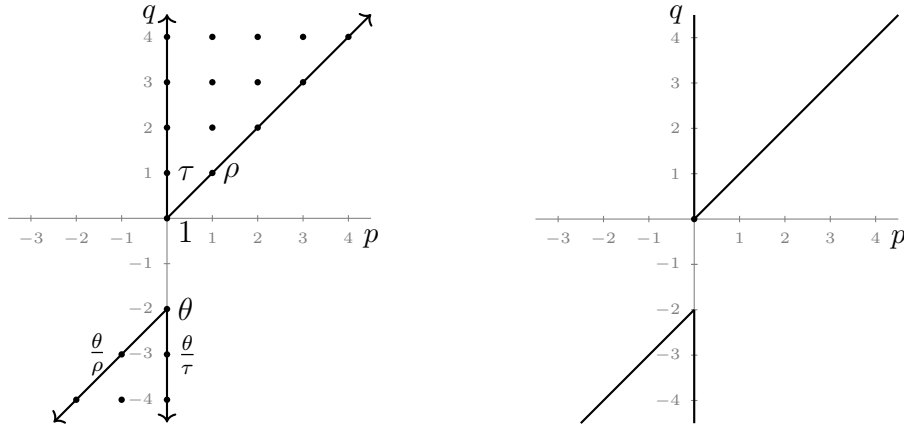

FIGURE 2.2 $\mathbb{M}_2 = H^{*,*}(pt)$

with the more succinct version on the right. Every lattice point inside the cones represents a copy of the group \mathbb{F}_2 . There are unique nonzero elements $\rho \in H^{1,1}(pt)$ and $\tau \in H^{0,1}(pt)$. As an $\mathbb{F}_2[\rho, \tau]$ -module \mathbb{M}_2 splits as $\mathbb{M}_2 = \mathbb{M}_2^+ \oplus \mathbb{M}_2^-$ where the top cone \mathbb{M}_2^+ is a polynomial algebra with generators ρ and τ . The bottom cone \mathbb{M}_2^- has a unique nonzero element $\theta \in H^{0,-2}(pt)$ that is infinitely divisible by both ρ and τ and satisfies $\theta^2 = 0$. We say that every element of the lower cone is ρ -torsion, meaning it is zero when multiplied by some power of ρ . Likewise, we say that every element of the lower cone is τ -torsion, since every element is zero when multiplied

by some power of τ . Notice the lower cone is a non-finitely generated ideal, so \mathbb{M}_2 is an infinitely generated commutative non-Noetherian \mathbb{F}_2 -algebra.

Since there is always an equivariant map $X \rightarrow pt$ for any space X , its cohomology $H^{*,*}(X)$ is a bigraded \mathbb{M}_2 -module. We are interested in cohomology, so throughout this paper we are working in the category of bigraded \mathbb{M}_2 -modules. By \mathbb{M}_2 -module we always mean bigraded \mathbb{M}_2 -module, and any reference to an \mathbb{M}_2 -module map means a bigraded homomorphism. In general, computing the cohomology of a C_2 -space, even as an \mathbb{M}_2 -module, is nontrivial.

2.2. Cohomology of the Antipodal Sphere

Let S_a^n denote the n -dimensional sphere with the antipodal C_2 -action. We write \mathbb{A}_n for the cohomology of S_a^n as an \mathbb{M}_2 -module. A picture of \mathbb{A}_n is shown in Figure 2.3. Again, on the left is a more detailed depiction (actually of \mathbb{A}_4), while

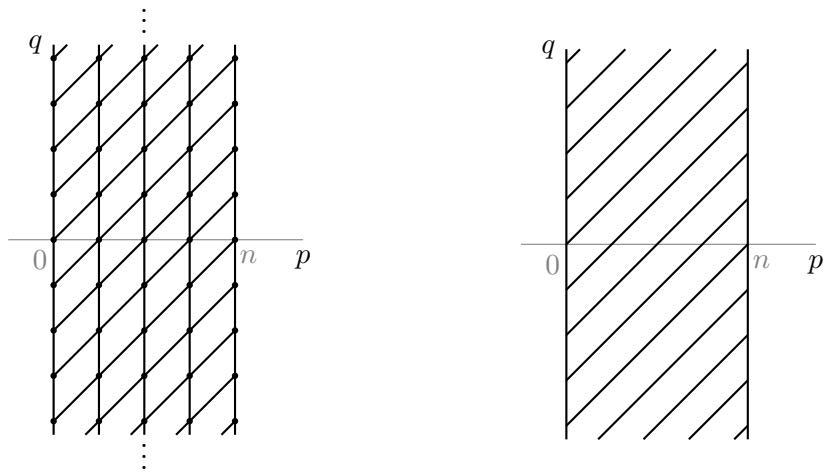

FIGURE 2.3 $\mathbb{A}_n = H^{*,*}(S_a^n)$

in practice it is more convenient to draw the succinct version on the right. Here every lattice point in the infinite strip of width $n + 1$ represents an \mathbb{F}_2 . Diagonal

lines represent multiplication by ρ and vertical lines represent multiplication by τ . Every nonzero element in \mathbb{A}_n is ρ -torsion, in the image of τ , and not τ -torsion. We allow for $n = 0$ since $C_2 = S_a^0$ and the cohomology of C_2 can be depicted by a single vertical line. As a ring $\mathbb{A}_n \cong \mathbb{F}_2[\tau, \tau^{-1}, \rho]/(\rho^{n+1})$ where ρ and τ correspond to multiplication by the usual elements in \mathbb{M}_2 and τ^{-1} has bidegree $(0, -1)$.

CHAPTER III

COMPUTATIONAL TOOLS

In this chapter we present some common tools for computing $RO(C_2)$ -graded cohomology of C_2 -spaces. If X is a C_2 -CW complex then X has a filtration coming from the cell structure. The filtration quotients X_n/X_{n-1} are wedges of copies of $C_{2+} \wedge S^n$ and $S^{n,0}$ corresponding to the orbit cells that were attached.

More generally, suppose we are given any filtration of a pointed C_2 -space X

$$pt \subseteq X_0 \subseteq X_1 \subseteq \cdots \subseteq X_k \subseteq X_{k+1} \subseteq \cdots \subseteq X.$$

Corresponding to the cofiber sequence

$$X_k \hookrightarrow X_{k+1} \rightarrow X_{k+1}/X_k,$$

for each weight q there is a long exact sequence¹

$$\cdots \rightarrow \tilde{H}^{p,q}(X_{k+1}/X_k) \rightarrow \tilde{H}^{p,q}(X_{k+1}) \rightarrow \tilde{H}^{p,q}(X_k) \xrightarrow{d} \tilde{H}^{p+1,q}(X_{k+1}/X_k) \rightarrow \cdots.$$

Taken collectively for all p and q , each map in the long exact sequence is a graded \mathbb{M}_2 -module map. By abuse, we often refer to the long exact sequences taken collectively for all q as “the long exact sequence.” Then d is a graded \mathbb{M}_2 -module map $d : \tilde{H}^{*,*}(X_k) \rightarrow \tilde{H}^{*+1,*}(X_{k+1}/X_k)$, which we call “the differential” in the long exact sequence. From this long exact sequence, there is a short exact sequence of

¹As Kronholm discusses in [7], these long exact sequences sew together in the usual way to give a spectral sequence for each weight q .

graded \mathbb{M}_2 -modules

$$0 \rightarrow \text{cok } d \rightarrow \tilde{H}^{*,*}(X_{k+1}) \rightarrow \text{ker } d \rightarrow 0.$$

In many cases the modules $\text{cok } d$ and $\text{ker } d$ are relatively easily determined, and computing $\tilde{H}^{*,*}(X_{k+1})$ requires solving the extension problem presented in this short exact sequence.

It is convenient to plot the bigraded cohomology in the plane with the topological dimension p along the horizontal axis and the weight q along the vertical axis, as in the depictions of \mathbb{M}_2 and \mathbb{A}_n . The differential d in the long exact sequence is depicted by a horizontal arrow since it increases topological dimension by one. When $\tilde{H}^{*,*}(X_k)$ is free as an \mathbb{M}_2 -module, i.e. when

$$\tilde{H}^{*,*}(X_k) \cong \mathbb{M}_2\langle \gamma_1, \dots, \gamma_k \rangle$$

the differential d is determined by its image on the basis elements $d(\gamma_i)$.

As a special case of the long exact sequence above, we obtain a long exact sequence that relates the ordinary $RO(C_2)$ -graded cohomology of a C_2 -space X to the non-equivariant singular cohomology of the underlying space X . From the cofiber sequence

$$C_{2+} \rightarrow S^{0,0} \rightarrow S^{1,1}$$

smashing with X gives the cofiber sequence

$$C_{2+} \wedge X \rightarrow S^{0,0} \wedge X \rightarrow S^{1,1} \wedge X$$

which induces a long exact sequence in cohomology for each weight q . Using this long exact sequence along with the suspension isomorphism and an adjunction² we obtain the following lemma as in [7], originally due to Araki-Murayama [1].

Lemma 3.0.1. (*Forgetful long exact sequence*). *Let X be a pointed C_2 -space. Then for every q there is a long exact sequence*

$$\dots \rightarrow \tilde{H}^{p,q}(X) \xrightarrow{\cdot\rho} \tilde{H}^{p+1,q+1}(X) \xrightarrow{\psi} \tilde{H}_{sing}^{p+1}(X) \rightarrow \tilde{H}^{p+1,q}(X) \rightarrow \dots$$

where $\cdot\rho$ is multiplication by $\rho \in \mathbb{M}_2$ and $\psi : \tilde{H}^{p,q}(X) \rightarrow \tilde{H}_{sing}^p(X)$ is the forgetful map³ to the singular cohomology of the underlying space with \mathbb{F}_2 coefficients.

²The suspension isomorphism for $RO(G)$ -graded cohomology means that

$$H_G^V(X; M) \cong \tilde{H}_G^{V+W}(X_+ \wedge S^W; M).$$

The adjunction isomorphism implies

$$[G_+ \wedge X, Y]_G \cong [X, U(Y)]_e$$

for any finite group G , where on the left we have homotopy classes of G -equivariant maps and on the right homotopy classes of non-equivariant maps between the underlying spaces. See [8].

³The forgetful map $\psi : H^{*,*}(pt) \rightarrow H_{sing}^*(pt)$ sends $\rho \mapsto 0$ and $\tau \mapsto 1$.

CHAPTER IV

GRADED MODULES AND COHOMOLOGY

We now introduce a number of technical lemmas that will aid in the proof of Theorem 5.0.1, our main theorem. First we show that θ detects copies of \mathbb{M}_2 in the sense that an element in any \mathbb{M}_2 -module with a nonzero θ -multiple generates a free submodule. Morally this is because there is only one element in \mathbb{M}_2 with a nonzero θ -multiple, the generator 1 of the ring. Moreover, since θ is infinitely divisible by ρ and τ , an element with a nonzero θ -multiple cannot have any ρ or τ torsion.

Lemma 4.0.1. *Let N be a graded \mathbb{M}_2 -module containing a nonzero homogeneous element x . If θx is nonzero, then $\mathbb{M}_2\langle x \rangle$ is a graded free submodule of N .*

Proof. We will show $\mathbb{M}_2\langle x \rangle \subseteq N$ by showing all \mathbb{M}_2 -multiples of x are nonzero, i.e. that $\rho^m \tau^n x$ and $\frac{\theta}{\rho^m \tau^n} x$ are nonzero for all $m, n \geq 0$. Since θx is nonzero and elements of \mathbb{M}_2 commute we have

$$0 \neq \theta x = \frac{\theta}{\rho^m \tau^n} \cdot \rho^m \tau^n x = \rho^m \tau^n \cdot \frac{\theta}{\rho^m \tau^n} x.$$

This implies $\rho^m \tau^n x$ and $\frac{\theta}{\rho^m \tau^n} x$ cannot be zero for any nonnegative choice of m or n . So the submodule generated by x is free. □

One can show that \mathbb{M}_2 is self-injective, meaning the regular module is injective, using a graded version of Baer's criterion.

Proposition 4.0.2. *The regular module \mathbb{M}_2 is injective as a graded \mathbb{M}_2 -module.*

Proof. The proof is somewhat tedious and not particularly enlightening. The details can be found in Appendix A. □

So far, the results in this chapter have been purely algebraic and hold for graded \mathbb{M}_2 -modules in general. The next result is specific to the cohomology of a finite C_2 -CW complex as an \mathbb{M}_2 -module. We have already observed a relationship between multiplication by ρ and singular cohomology of the underlying space via the forgetful long exact sequence. We now show that localization by ρ relates the equivariant cohomology of a space to the singular cohomology of its fixed set. In the proof of our main theorem, we will see this restricts the types of \mathbb{M}_2 -modules that can arise as the cohomology of a space.

Lemma 4.0.3. (*ρ -localization*) *Let X be a finite¹ C_2 -CW complex. Then*

$$\rho^{-1}H^{*,*}(X) \cong \rho^{-1}H^{*,*}(X^{C_2}) \cong H_{sing}^*(X^{C_2}) \otimes_{\mathbb{F}_2} \rho^{-1}\mathbb{M}_2.$$

Proof. The inclusion $X^{C_2} \xrightarrow{i} X$ induces $\rho^{-1}H^{*,*}(X) \xrightarrow{\rho^{-1}i^*} \rho^{-1}H^{*,*}(X^{C_2})$. For locally finite, finite-dimensional C_2 -CW complexes, $\rho^{-1}H^{*,*}(-)$ is a cohomology theory because localization is exact. On the other hand, $H^{*,*}((-)^{C_2})$ is a cohomology theory because the fixed-set functor $(-)^{C_2}$ preserves Puppe sequences. So $\rho^{-1}H^{*,*}((-)^{C_2})$ is also a cohomology theory. It is easily verified that $\rho^{-1}H^{*,*}(-)$ and $\rho^{-1}H^{*,*}((-)^{C_2})$ agree on both orbits, $C_2/C_2 = pt$ and $C_2/e = C_2$, and hence are naturally isomorphic cohomology theories via $\rho^{-1}i^*$. This proves the first isomorphism above. The second isomorphism, which relates ρ -localization to singular cohomology, follows from the fact that X^{C_2} has trivial action and so has a cellular filtration involving only trivial cells. □

¹Note that finite-dimensionality is required. A counterexample that is locally finite but not finite-dimensional is the infinite-dimensional sphere with the antipodal action S_a^∞ . It has empty fixed-set but $\mathbb{A}_\infty = H^{*,*}(S_a^\infty) \cong \mathbb{F}_2[\tau, \tau^{-1}, \rho]$ and $\rho^{-1}\mathbb{A}_\infty$ is nontrivial.

Remark 4.0.4. An important consequence is that if X is a finite C_2 -CW complex, then $\rho^{-1}H^{*,*}(X)$ does not have any τ -torsion since $\rho^{-1}\mathbb{M}_2 \cong \mathbb{F}_2[\tau, \rho, \rho^{-1}]$ and $\rho^{-1}H^{*,*}(X)$ is free over $\rho^{-1}\mathbb{M}_2$.

4.1. Toda Brackets

Just as in classical topology, the pairings on $H^{*,*}(-)$ give rise to higher products given by Toda brackets. The next proposition involves a higher order decomposition of 1 in the ring \mathbb{M}_2 . This result will also restrict the types of \mathbb{M}_2 -modules that can arise as the cohomology of a space.

Proposition 4.1.1. *In \mathbb{M}_2 , we have the following Toda bracket*

$$\langle \tau, \theta, \rho \rangle = 1$$

with zero indeterminacy.

Proof. First notice that the Toda bracket $\langle \tau, \theta, \rho \rangle$ is well defined since $\theta\rho = 0 = \tau\theta$ in \mathbb{M}_2 for degree reasons. Also notice there is zero indeterminacy because the indeterminacy of the bracket is the double coset $\tau H^{0,-1}(pt) + H^{-1,-1}(pt)\rho \equiv 0$. So $\langle \tau, \theta, \rho \rangle$ is a set containing a single element of $H^{0,0}(pt) \cong \mathbb{F}_2$. In order to compute $\langle \tau, \theta, \rho \rangle$ we need to determine whether this element is trivial or not.

We will use geometric models for the elements τ , θ , and ρ to prove this Toda bracket is nontrivial. From [3], a model for the (p, q) -th Eilenberg MacLane space representing $\tilde{H}^{p,q}(-; \mathbb{F}_2)$ is $K(\mathbb{F}_2(p, q)) \simeq \mathbb{F}_2\langle S^{p,q} \rangle$. This is the usual Dold-Thom model given by configurations of points on $S^{p,q}$ with labels in \mathbb{F}_2 . The action on the configurations is inherited from $S^{p,q}$.

We can consider ρ geometrically via

$$\rho \in H^{1,1}(pt) \cong [S^{0,0}, K(\mathbb{F}_2(1, 1))]_{C_2} \cong [S^{0,0}, \mathbb{F}_2\langle S^{1,1} \rangle]_{C_2}.$$

Or equivalently, using the loop-suspension adjunction

$$\begin{aligned} \rho \in H^{1,1}(pt) &\cong [S^{0,0}, K(\mathbb{F}_2(1, 1))]_{C_2} \\ &\cong [S^{0,0}, \Omega^{1,1}K(\mathbb{F}_2(2, 2))]_{C_2} \\ &\cong [S^{1,1}, K(\mathbb{F}_2(2, 2))]_{C_2} \\ &\cong [S^{1,1}, \mathbb{F}_2\langle S^{2,2} \rangle]_{C_2}. \end{aligned}$$

On the other hand, we can consider θ geometrically via

$$\begin{aligned} \theta \in H^{0,-2}(pt) &\cong [S^{0,0}, K(\mathbb{F}_2(0, -2))]_{C_2} \\ &\cong [S^{0,0}, \Omega^{2,2}K(\mathbb{F}_2(2, 0))]_{C_2} \\ &\cong [S^{2,2}, K(\mathbb{F}_2(2, 0))]_{C_2} \\ &\cong [S^{2,2}, \mathbb{F}_2\langle S^{2,0} \rangle]_{C_2}. \end{aligned}$$

Both ρ and θ are in the image of the Hurewicz map and factor as

$$\begin{array}{ccc} S^{0,0} & \xrightarrow{\rho} & \mathbb{F}_2\langle S^{1,1} \rangle \\ & \searrow \tilde{\rho} & \nearrow \iota \\ & S^{1,1} & \end{array} \qquad \begin{array}{ccc} S^{2,2} & \xrightarrow{\theta} & \mathbb{F}_2\langle S^{2,0} \rangle \\ & \searrow \tilde{\theta} & \nearrow \iota \\ & S^{2,0} & \end{array}$$

where ι is the canonical map sending each point x to the configuration $[x]$. Here $\tilde{\rho}$ includes $S^{0,0}$ as the fixed-set of $S^{1,1}$. This is because ρ is the unique nontrivial element in $H^{1,1}(pt)$ and the composition $\iota \circ \tilde{\rho}$ is not null when restricted to the fixed-sets. In the following proof we will actually use $\Sigma^{1,1}\tilde{\rho} : S^{1,1} \rightarrow S^{2,2}$, the

inclusion of a meridian, which factors ρ viewed as a map $\rho : S^{1,1} \rightarrow \mathbb{F}_2\langle S^{2,2} \rangle$. Again $\iota \circ \Sigma^{1,1} \tilde{\rho}$ is not null when restricted to fixed-sets. Since the target of θ is fixed by the C_2 -action, θ factors through the quotient. The quotient map $\tilde{\theta} : S^{2,2} \rightarrow S^{2,2}/C_2$ is a degree 2 map on the underlying sphere S^2 .

For τ we observe

$$\begin{aligned}
\tau \in H^{0,1}(pt) &\cong [S^{0,0}, K(\underline{\mathbb{F}}_2(0, 1))]_{C_2} \\
&\cong [S^{0,0}, \Omega^{1,0} K(\underline{\mathbb{F}}_2(1, 1))]_{C_2} \\
&\cong [S^{1,0}, K(\underline{\mathbb{F}}_2(1, 1))]_{C_2} \\
&\cong [S^{1,0}, \mathbb{F}_2\langle S^{1,1} \rangle]_{C_2} \\
&\cong [S^{2,0}, \mathbb{F}_2\langle S^{2,1} \rangle]_{C_2}.
\end{aligned}$$

We will not actually need a geometric model for τ to prove the Toda bracket is nontrivial. We will need the fact that the forgetful map $\psi : H^{*,*}(pt) \rightarrow H_{sing}^*(pt)$ sends $\tau \mapsto 1$ in the forgetful long exact sequence from Lemma 3.0.1.

We are now ready to compute the Toda bracket via the composition

$$S^{1,1} \xrightarrow{\Sigma^{1,1} \tilde{\rho}} S^{2,2} \xrightarrow{\tilde{\theta}} S^{2,0} \xrightarrow{\tau} \mathbb{F}_2\langle S^{2,1} \rangle.$$

Using the Puppe sequence

$$S^{1,1} \rightarrow S^{2,2} \rightarrow C_{2+} \wedge S^2 \rightarrow S^{2,1} \rightarrow \dots$$

we can choose maps f and g so the following diagram

$$\begin{array}{ccccccc}
S^{1,1} & \xrightarrow{\Sigma^{1,1}\tilde{\rho}} & S^{2,2} & \xrightarrow{\tilde{\theta}} & S^{2,0} & \xrightarrow{\tau} & \mathbb{F}_2\langle S^{2,1} \rangle \\
& & \downarrow & \nearrow f & & & \nearrow \\
& & C_{2+} \wedge S^2 & & & & \\
& & \downarrow & & & & \nearrow g \\
& & S^{2,1} & & & &
\end{array}$$

commutes up to homotopy. There is no indeterminacy so $\langle \tau, \theta, \rho \rangle = g$. It remains to show g is not nullhomotopic. Notice that we can choose f to be the fold map. Using the adjunction isomorphism, $\tau \circ f$ is an element of the group

$$[C_{2+} \wedge S^2, \mathbb{F}_2\langle S^{2,1} \rangle]_{C_2} \cong [S^2, \mathbb{F}_2\langle S^2 \rangle]_e \cong [S^0, \mathbb{F}_2\langle S^0 \rangle]_e$$

corresponding to $\psi(\tau)$, which is not null. That is, $C_{2+} \wedge S^2 \rightarrow S^{2,1}$ projects each S^2 isomorphically onto $S^{2,1}$. The diagram commutes up to homotopy so g cannot be null on the underlying spaces. Hence $g \simeq \iota$ and $\langle \tau, \theta, \rho \rangle = 1$. \square

The key to this proof is to find nice geometric models for ρ and θ , and then to recognize we may choose f to be the fold map. A more algebraic proof, suggested by Dan Isaksen, makes use of the relationship between Toda brackets and “hidden extensions.” More details about this relationship can be found in Section 3.1.1 of [6]. In particular, we observe the Toda bracket $\langle \tau, \theta, \rho \rangle = 1$ is equivalent to a hidden τ -extension in the cohomology of the cofiber of ρ . Though it is not required, for the sake of consistency with the previous proof the following discussion demonstrates this hidden extension argument for the cofiber of $\Sigma^{1,1}\tilde{\rho}$.

In the previous argument we observed that $\tau \circ f$ was not null geometrically to deduce that g was not null. The key to the more algebraic proof is to consider essentially the same diagram and recognize that $\tau \circ f$ is an element of

$\tilde{H}^{2,1}(C_{2+} \wedge S^2)$. We can observe this element is nonzero by an easy computation in cohomology. Then deduce that g is not null as before.

In the Puppe sequence used to compute the Toda bracket above, we have the cofiber sequence $S^{2,2} \rightarrow C_{2+} \wedge S^2 \rightarrow S^{2,1}$. Associated to this cofiber sequence there is a long exact sequence in cohomology. By construction the differential will send the generator of $\Sigma^{2,2}\mathbb{M}_2 \cong \tilde{H}^{*,*}(S^{2,2})$ to ρ times the generator of $\Sigma^{2,1}\mathbb{M}_2 \cong \tilde{H}^{*,*}(S^{2,1})$ as depicted in Figure 4.1.

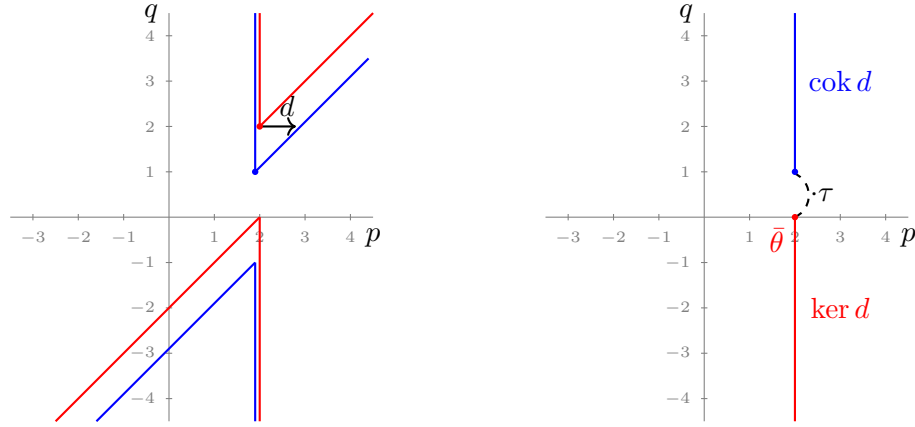

FIGURE 4.1 Hidden τ extension in $\tilde{H}^{*,*}(C_{2+} \wedge S^2)$.

Usually, to compute $\tilde{H}^{*,*}(C_{2+} \wedge S^2)$ we would need to solve the associated extension problem

$$0 \rightarrow \text{cok } d \rightarrow \tilde{H}^{*,*}(C_{2+} \wedge S^2) \rightarrow \text{ker } d \rightarrow 0.$$

But of course we already know from the suspension isomorphism that

$$\tilde{H}^{*,*}(C_{2+} \wedge S^2) \cong \Sigma^{2,0}\mathbb{A}_0.$$

In particular, multiplication by τ is an isomorphism here. The element $\theta \in \ker d$ contributes a nonzero element $\bar{\theta} \in \tilde{H}^{*,*}(C_{2+} \wedge S^2)$ and we see the extension problem must be solved by a hidden τ -extension given by $\tau\bar{\theta} \neq 0$. If we replace f with $\bar{\theta}$, we see this is equivalent to showing $\tau \circ f$ is not null in the previous proof. Therefore g cannot be null and again we conclude $\langle \tau, \theta, \rho \rangle = 1$.

Armed with this Toda bracket we obtain a matrix Toda bracket.

Lemma 4.1.2. *In \mathbb{M}_2 , we have the following matrix Toda bracket*

$$\left\langle \begin{bmatrix} \rho & \tau \end{bmatrix}, \begin{bmatrix} \tau \\ \rho \end{bmatrix}, \theta \right\rangle = 1$$

with zero indeterminacy.

Proof. Notice the matrix Toda bracket is defined because $\tau\theta = 0 = \rho\theta$. Again there is zero indeterminacy because $H^{0,2}(pt)\theta \equiv 0$, so the matrix Toda bracket is a single element of $H^{0,0}(pt) \cong \mathbb{F}_2$. Since $\langle \tau, \theta, \rho \rangle = 1$ we can use a juggling formula to shift the bracket and write

$$\begin{aligned} \left\langle \begin{bmatrix} \rho & \tau \end{bmatrix}, \begin{bmatrix} \tau \\ \rho \end{bmatrix}, \theta \right\rangle \cdot \rho &= \begin{bmatrix} \rho & \tau \end{bmatrix} \cdot \left\langle \begin{bmatrix} \tau \\ \rho \end{bmatrix}, \theta, \rho \right\rangle \\ &= \rho \cdot \langle \tau, \theta, \rho \rangle + \tau \cdot \langle \rho, \theta, \rho \rangle \\ &= \rho \cdot 1 + \tau \cdot 0 \\ &= \rho \end{aligned}$$

where $\langle \rho, \theta, \rho \rangle = 0$ for degree reasons. The matrix Toda bracket is an element of $H^{0,0}(pt)$ that is nonzero when multiplied by ρ , so it must be nonzero. This completes the proof. □

Using these two Toda brackets and juggling formulas we get a number of results restricting the types of \mathbb{M}_2 -modules we can see in cohomology. We present these results more generally as restrictions on the homotopy of a spectrum. Let $H\underline{\mathbb{F}}_2$ denote the genuine equivariant Eilenberg-MacLane spectrum for $\underline{\mathbb{F}}_2$ so that its bigraded equivariant homotopy $\pi_{*,*}H\underline{\mathbb{F}}_2 = \mathbb{M}_2$. If C is an $H\underline{\mathbb{F}}_2$ -module then $\pi_{*,*}(C)$ is an \mathbb{M}_2 -module and has Toda brackets. In each of the following lemmas we take C to be any $H\underline{\mathbb{F}}_2$ -module. In particular, if X is a C_2 -CW complex, the function spectrum $F(X_+, H\underline{\mathbb{F}}_2)$ is an $H\underline{\mathbb{F}}_2$ -module, and we can realize $H^{**}(X)$ as $\pi_{-*,-*}F(X_+, H\underline{\mathbb{F}}_2) \cong H^{**}(X)$.

Lemma 4.1.3. *If $x \in \pi_{*,*}(C)$ and $\theta x = 0$, then $x \in (\rho, \tau)\pi_{*,*}(C)$.*

Proof. Assume $\theta x = 0$. Then

$$\begin{aligned} x &= 1 \cdot x = \left\langle \left[\begin{array}{cc} \rho & \tau \end{array} \right], \left[\begin{array}{c} \tau \\ \rho \end{array} \right], \theta \right\rangle \cdot x \\ &= \left[\begin{array}{cc} \rho & \tau \end{array} \right] \cdot \left\langle \left[\begin{array}{c} \tau \\ \rho \end{array} \right], \theta, x \right\rangle \\ &= \rho \cdot \langle \tau, \theta, x \rangle + \tau \cdot \langle \rho, \theta, x \rangle, \end{aligned}$$

which completes the proof. □

Lemma 4.1.4. *If $x \in \pi_{*,*}(C)$ and $\rho x = \tau x = 0$ then $x \in (\theta)\pi_{*,*}(C)$.*

Proof. Assume $\rho x = \tau x = 0$. Then

$$x = x \cdot 1 = x \cdot \left\langle \left[\begin{array}{cc} \rho & \tau \end{array} \right], \left[\begin{array}{c} \tau \\ \rho \end{array} \right], \theta \right\rangle = \left\langle x, \left[\begin{array}{cc} \rho & \tau \end{array} \right], \left[\begin{array}{c} \tau \\ \rho \end{array} \right] \right\rangle \cdot \theta,$$

which completes the proof. \square

Lemma 4.1.5. *If $x \in \pi_{*,*}(C)$ and $\tau x = 0$ then $x \in (\rho)\pi_{*,*}(C)$.*

Proof. Assume $\tau x = 0$. Then $x = 1 \cdot x = x \cdot \langle \tau, \theta, \rho \rangle = \langle x, \tau, \theta \rangle \cdot \rho$ so we are done. \square

Lemma 4.1.6. *If $x \in \pi_{*,*}(C)$ and $\rho x = 0$ then $x \in (\tau)\pi_{*,*}(C)$.*

Proof. The proof is analogous. \square

Next we observe two vanishing regions in the cohomology of any finite C_2 -CW complex. These regions are depicted on the left side of Figure 4.2.

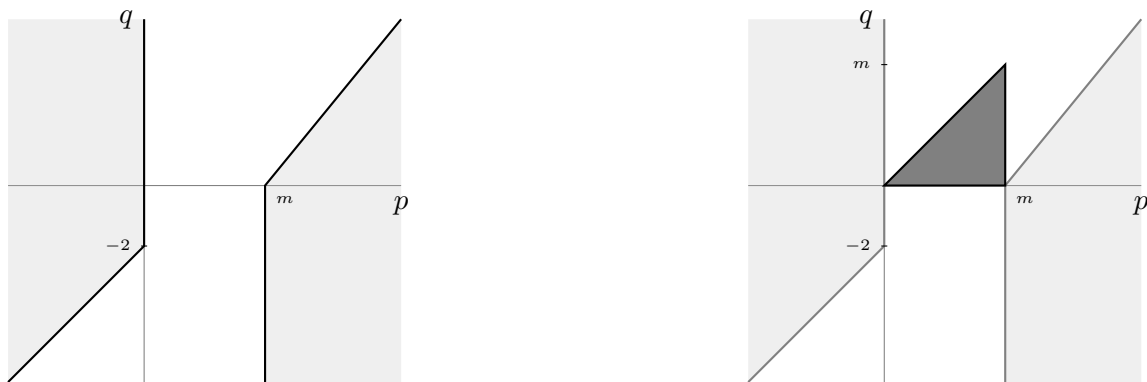

FIGURE 4.2 Vanishing regions and region containing \mathbb{M}_2 generators.

Lemma 4.1.7. *If X is a finite C_2 -CW complex of dimension m then $H^{p,q}(X) = 0$*

1. *whenever $p < 0$ and $q > p - 2$, and*
2. *whenever $p > m$ and $q < p - m$.*

Proof. Both statements follow easily by induction on the C_2 -CW filtration for X since the cohomologies of the orbits $\mathbb{M}_2 = H^{*,*}(pt)$ and $\mathbb{A}_0 = H^{*,*}(C_2)$ satisfy these vanishing regions. \square

An immediate corollary restricts the bidegree of a generator for a shifted copy of \mathbb{M}_2 in $H^{*,*}(X)$. The region where \mathbb{M}_2 generators can lie is depicted by the triangle on the right side of Figure 4.2.

Corollary 4.1.8. *Let X be a finite C_2 -CW complex with dimension m . Any generator for a copy of \mathbb{M}_2 in $H^{*,*}(X)$ must lie in a bidegree (p, q) that corresponds to an actual representation, with topological dimension p satisfying $0 \leq p \leq m$ and weight $0 \leq q \leq p$.*

Proof. The proof follows immediately from Lemma 4.1.7 since otherwise the copy of \mathbb{M}_2 would intersect one of the vanishing regions. \square

The last lemma in this chapter is key to the proof of the main theorem as we now show that if θ acts trivially on a nice submodule of $H^{*,*}(X)$, then every element is not τ -torsion and is infinitely divisible by τ , making the submodule an $\mathbb{F}_2[\tau, \tau^{-1}, \rho]$ -module.

Lemma 4.1.9. *Let X be a finite C_2 -CW complex and let C be an $H\mathbb{F}_2$ -module with $\pi_{*,*}(C) \subseteq H^{*,*}(X)$. Suppose that, as an \mathbb{M}_2 -module, $\pi_{*,*}(C)$ is a direct summand of $H^{*,*}(X)$, and that $\theta x = 0$ for all $x \in \pi_{*,*}(C)$. Then $\cdot\tau : \pi_{*,*}(C) \rightarrow \pi_{*,*}(C)$ is an automorphism, making $\pi_{*,*}(C)$ naturally an $\mathbb{F}_2[\tau, \tau^{-1}, \rho]$ -module.*

Proof. First we show that multiplication by τ is injective. If there exists a nonzero element $x \in \pi_{*,*}(C)$ with $\tau x = 0$, then there are two cases, either $\rho x = 0$ or $\rho x \neq 0$. Both cases lead to a contradiction.

1. Suppose $\rho x = 0$. Then by Lemma 4.1.4, x is in the image of multiplication by θ , contradicting that θ acts trivially on $\pi_{*,*}(C)$.

2. Suppose $\rho x \neq 0$. Then x is either killed by some power of ρ or x is not ρ -torsion. Either way we will arrive at a contradiction. Suppose for some n that $\rho^{n+1}x = 0$ but $\rho^n x \neq 0$, then $\rho^n x$ is killed by τ since ρ and τ commute:

$$\tau \rho^n x = \rho^n \tau x = 0.$$

But now $\rho^n x$ satisfies case (1), which we have already seen gives a contradiction. If instead x is not ρ -torsion, then x survives ρ -localization, and again we arrive at a contradiction. By Lemma 4.0.3, any elements surviving the ρ -localization of the cohomology of a finite space cannot be τ -torsion. Since $\pi_{*,*}(C)$ is a summand of $H^{*,*}(X)$, x cannot be τ -torsion, which contradicts the assumption that $\tau x = 0$.

So indeed, τx is nonzero for all $x \in \pi_{*,*}(C)$ and the map $\cdot\tau : \pi_{*,*}(C) \rightarrow \pi_{*,*}(C)$ is injective. Said another way, no elements of $\pi_{*,*}(C)$ are τ -torsion.

Notice that injectivity of $\cdot\tau$ means that any nonzero element $x \in \pi_{*,*}(C)$ has $\tau^m x \neq 0$ for all m . In particular, x cannot be in a bidegree with negative topological dimension. Otherwise, some τ -multiple of x would land in the first vanishing region and contradict Lemma 4.1.7. We will use this fact in the proof of surjectivity.

To show multiplication by τ is surjective, we assume to the contrary there is some nonzero homogenous element $y \in \pi_{*,*}(C)$ not in the image of $\cdot\tau$. We may further assume that y is an element of minimal topological dimension satisfying these hypotheses. We can make this minimality assumption because, as we have already observed, injectivity of $\cdot\tau$ implies all elements of $\pi_{*,*}(C)$ have nonnegative topological dimension.

Since $\theta y = 0$, Lemma 4.1.3 implies that $y \in (\rho, \tau)\pi_{*,*}(C)$. So we can write $y = \rho a + \tau b$ for some homogeneous elements $a, b \in \pi_{*,*}(C)$. Notice that $a \neq 0$, otherwise $y = \tau b$, contradicting our assumption that y is not in the image of $\cdot\tau$. The topological dimension of a is one less than the topological dimension of y . Since y had minimal topological dimension and a is nonzero, it must be that a is in the image of $\cdot\tau$. This means we can write $a = \tau c$ for some $c \in \pi_{*,*}(C)$, but now $y = \rho a + \tau b = \rho\tau c + \tau b = \tau(\rho c + b)$, contradicting that y is not in the image of $\cdot\tau$.

Surjectivity of $\cdot\tau$ completes the proof that multiplication by τ is an automorphism of $\pi_{*,*}(C)$ and so $\pi_{*,*}(C)$ is a $\mathbb{F}_2[\tau, \tau^{-1}, \rho]$ -module. □

CHAPTER V

MAIN THEOREM

We are now ready to state and prove the main theorem.

Theorem 5.0.1. *For any finite¹ C_2 -CW complex X , there is a decomposition of the $RO(C_2)$ -graded cohomology of X with constant \mathbb{F}_2 -coefficients as*

$$H^{*,*}(X; \mathbb{F}_2) \cong (\oplus_i \Sigma^{p_i, q_i} \mathbb{M}_2) \oplus (\oplus_j \Sigma^{r_j, 0} \mathbb{A}_{n_j})$$

as a module over $\mathbb{M}_2 = H^{*,*}(pt; \mathbb{F}_2)$, where \mathbb{R}^{p_i, q_i} and $\mathbb{R}^{r_j, 0}$ are elements of $RO(C_2)$ corresponding to actual representations.

Proof. Recall that θ detects copies of \mathbb{M}_2 . So if $x \in H^{*,*}(X)$ with $\theta x \neq 0$, then by Lemma 4.0.1 there is a free submodule $\mathbb{M}_2 \langle x \rangle \subseteq H^{*,*}(X)$. The short exact sequence of \mathbb{M}_2 -modules

$$0 \rightarrow \mathbb{M}_2 \langle x \rangle \rightarrow H^{*,*}(X) \rightarrow P \rightarrow 0$$

splits because \mathbb{M}_2 is injective (see Proposition 4.0.2). Continuing to split off summands in this way, we have the split short exact sequence

$$0 \rightarrow \oplus_i \Sigma^{p_i, q_i} \mathbb{M}_2 \rightarrow H^{*,*}(X) \rightarrow Q \rightarrow 0$$

where we can assume that every $x \in Q$ satisfies $\theta x = 0$. By Corollary 4.1.8, each bidegree (p_i, q_i) corresponds to an actual representation. Moreover, this process

¹Note that finiteness is again required here. One might hope for a generalization to locally finite C_2 -CW complexes by allowing shifted copies of A_∞ . A counterexample is given at the end of this chapter in Example 5.0.2.

terminates because by induction any given bidegree of $H^{*,*}(X)$ is finite-dimensional as a vector space.

We would now like to apply Lemma 4.1.9 to Q to show that Q is an $\mathbb{F}_2[\tau, \tau^{-1}, \rho]$ -module. However, in order to apply the lemma we need to realize Q as the homotopy of an $H\underline{\mathbb{F}}_2$ -module. We can realize $H^{*,*}(X)$ as the homotopy of a function spectrum $H^{*,*}(X) \cong \pi_{-*,-*}F(X_+, H\underline{\mathbb{F}}_2)$. Since $F(X_+, H\underline{\mathbb{F}}_2)$ is an $H\underline{\mathbb{F}}_2$ -module, each free generator u_i of $\Sigma^{p_i, q_i}\mathbb{M}_2$ in $H^{*,*}(X)$ gives rise to a map of spectra given by the composition

$$S^{-p_i, -q_i} \wedge H\underline{\mathbb{F}}_2 \xrightarrow{u_i \wedge id} F(X_+, H\underline{\mathbb{F}}_2) \wedge H\underline{\mathbb{F}}_2 \xrightarrow{\mu} F(X_+, H\underline{\mathbb{F}}_2).$$

Taking maps corresponding to each of the free generators of the shifted copies of \mathbb{M}_2 in $H^{*,*}(X)$, we obtain a map

$$\bigvee_i S^{-p_i, -q_i} \wedge H\underline{\mathbb{F}}_2 \rightarrow F(X_+, H\underline{\mathbb{F}}_2).$$

Let C be the cofiber of this map. The cofiber sequence induces a long exact sequence in homotopy of the form

$$\cdots \rightarrow \pi_{*+1,*}C \rightarrow \bigoplus_i \Sigma^{p_i, q_i}\mathbb{M}_2 \rightarrow H^{*,*}(X) \rightarrow \pi_{*,*}C \rightarrow \cdots$$

where by construction $\Sigma^{p_i, q_i}\mathbb{M}_2 \hookrightarrow H^{*,*}(X)$ is the inclusion of the copies of \mathbb{M}_2 from our original short exact sequence. Because this is an inclusion and \mathbb{M}_2 is self-injective, we get a split short exact sequence and $\pi_{*,*}C \cong Q$. We have now realized Q as the homotopy of an $H\underline{\mathbb{F}}_2$ -module, so Lemma 4.1.9 applies and indeed Q is an $\mathbb{F}_2[\tau, \tau^{-1}, \rho]$ -module.

We still need to show Q is finitely generated as an $\mathbb{F}_2[\tau, \tau^{-1}, \rho]$ -module, so we may decompose Q according to the graded version of the structure theorem for finitely generated modules over a graded PID. Observe that $\tau^{-1}\mathbb{M}_2 \cong \mathbb{F}_2[\tau, \tau^{-1}, \rho]$ and that $\tau^{-1}H^{*,*}(X)$ is finitely generated as a $\tau^{-1}\mathbb{M}_2$ -module. The latter follows from induction on the C_2 -CW filtration for X since $\tau^{-1}\mathbb{M}_2$ is a graded PID and the τ -localized cohomology of each orbit is finitely generated as a $\tau^{-1}\mathbb{M}_2$ -module. The submodule $Q \cong \tau^{-1}Q$ of $\tau^{-1}H^{*,*}(X)$ is also finitely generated as a $\tau^{-1}\mathbb{M}_2$ -module since $\tau^{-1}\mathbb{M}_2$ is Noetherian.

Finally, applying the fundamental theorem for finitely generated graded modules over a graded PID to Q , it must be the case that

$$Q \cong \tau^{-1}Q \cong (\oplus_k \Sigma^{p_k, q_k} \tau^{-1}\mathbb{M}_2) \oplus (\oplus_j \Sigma^{r_j, 0} \tau^{-1}\mathbb{M}_2 / (\rho^{n_j+1}))$$

where again we identify $\tau^{-1}\mathbb{M}_2 \cong \mathbb{F}_2[\tau, \tau^{-1}, \rho]$. However, X is a finite C_2 -CW complex, so the second vanishing region from Lemma 4.1.7 implies Q cannot contain any summands of the form $\Sigma^{p_k, q_k} \tau^{-1}\mathbb{M}_2$. This means

$$Q \cong \tau^{-1}Q \cong \oplus_j \Sigma^{r_j, 0} \tau^{-1}\mathbb{M}_2 / (\rho^{n_j+1}) \cong \oplus_j \Sigma^{r_j, 0} \mathbb{A}_{n_j} \cong \oplus_j \Sigma^{r_j, 0} H^{*,*}(S_a^{n_j}).$$

Finally we can conclude that

$$H^{*,*}(X; \underline{\mathbb{F}}_2) \cong (\oplus_i \Sigma^{p_i, q_i} \mathbb{M}_2) \oplus Q \cong (\oplus_i \Sigma^{p_i, q_i} \mathbb{M}_2) \oplus (\oplus_j \Sigma^{r_j, 0} \mathbb{A}_{n_j})$$

as desired. □

The reader may notice we used the condition that X was finite several times in the previous proof. At first glance, one might expect a generalization of the

structure theorem to locally finite C_2 -CW complexes if we allow shifted copies of A_∞ . This seems plausible because S_a^∞ is locally finite. As further evidence, $A_\infty \cong \tau^{-1}\mathbb{M}_2 \cong \mathbb{F}_2[\tau, \tau^{-1}, \rho]$ appears near the end of the proof as part of the fundamental theorem for finitely generated graded modules over a graded PID. The following counterexample demonstrates that such a generalization would also need to include other types of \mathbb{M}_2 -modules.

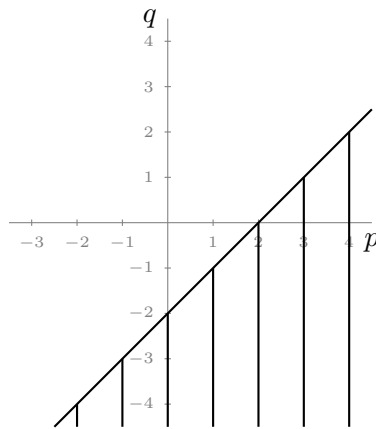

FIGURE 5.1 Cohomology of $S^{\infty, \infty}$.

Example 5.0.2. In this example we consider an infinite-dimensional locally finite C_2 -CW complex whose cohomology is not A_∞ . Consider the C_2 -CW complex $S^{\infty, \infty}$ formed by the colimit of the diagram

$$S^{0,0} \rightarrow S^{1,1} \rightarrow S^{2,2} \rightarrow \dots \rightarrow S^{n,n} \rightarrow \dots$$

where each map is a suspension of $\tilde{\rho} : S^{0,0} \rightarrow S^{1,1}$. Notice that $S^{\infty, \infty}$ can be given a cell structure with two fixed points and a single equivariant n -cell $C_2 \times D^n$ for every $n > 0$. Alternatively, $S^{\infty, \infty}$ can be realized as the unreduced suspension of S_a^∞ . Its cohomology is depicted in Figure 5.1. More precisely, we can describe $H^{*,*}(S^{\infty, \infty})$

as $\Sigma^{0,-1}N$, where N is the quotient in the category of graded \mathbb{M}_2 -modules in the short exact sequence

$$0 \rightarrow \mathbb{M}_2[\rho^{-1}] \rightarrow \mathbb{M}_2[\tau^{-1}\rho^{-1}] \rightarrow N \rightarrow 0.$$

CHAPTER VI

APPLICATIONS

In this chapter we present some applications of the main theorem.

6.1. Computational Applications

We begin with some examples that illustrate common computational techniques and demonstrate how the main theorem simplifies computations. In the first example we will use the following fact, which implies we can compute the p -axis of the $RO(C_2)$ -graded cohomology¹ of a space using the singular cohomology of the quotient.

Lemma 6.1.1. *Let X be a C_2 -space. Then $H^{p,0}(X) \cong H_{sing}^p(X/C_2)$.*

Proof. This follows from working with coefficients in a constant Mackey functor.

Recall from [3], a model for the (p, q) -th Eilenberg MacLane space is given by $K(\mathbb{F}_2(p, q)) \simeq \mathbb{F}_2\langle S^{p,q} \rangle$, the usual Dold-Thom model given by configurations of points on $S^{p,q}$ with labels in \mathbb{F}_2 . In particular, $K(\mathbb{F}_2(p, 0)) \simeq \mathbb{F}_2\langle S^{p,0} \rangle$. Since $S^{p,0}$ is fixed, so is the space $\mathbb{F}_2\langle S^{p,0} \rangle$. By adjunction

¹The p -axis of the $RO(C_2)$ -graded cohomology is the \mathbb{Z} -graded equivariant cohomology originally defined by Bredon.

$$\begin{aligned}
H^{p,0}(X) &\cong [X_+, K(\mathbb{F}_2(p, 0))]_{C_2} \\
&\cong [X_+, \mathbb{F}_2\langle S^{p,0} \rangle]_{C_2} \\
&\cong [X_+/C_2, U(\mathbb{F}_2\langle S^{p,0} \rangle)]_e \\
&\cong [X_+/C_2, \mathbb{F}_2\langle S^p \rangle]_e \\
&\cong H_{sing}^p(X/C_2),
\end{aligned}$$

where the last isomorphism follows from the non-equivariant Dold-Thom model for singular cohomology. □

Example 6.1.2. In this example we compute the cohomology of the projective space $\mathbb{R}P_{tw}^2 = \mathbb{P}(\mathbb{R}^{3,1})$ using Lemma 6.1.1 and our main theorem. A picture of $\mathbb{R}P_{tw}^2$ is shown in Figure 6.1. This is the usual diagram for $\mathbb{R}P^2$ given by a disk with opposite points on the boundary identified. The C_2 -action is given by rotating the picture 180° leaving a fixed point in the center and a fixed circle on the boundary.

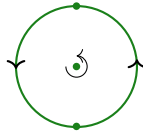

FIGURE 6.1 $\mathbb{R}P_{tw}^2$

The long exact sequence associated to the cofiber sequence $S^{1,0} \hookrightarrow \mathbb{R}P_{tw}^2 \rightarrow S^{2,2}$ is depicted on the left side of Figure 6.2. Recall that in these depictions every lattice point inside the cones represents a copy of \mathbb{F}_2 and the differential increases topological dimension by one.

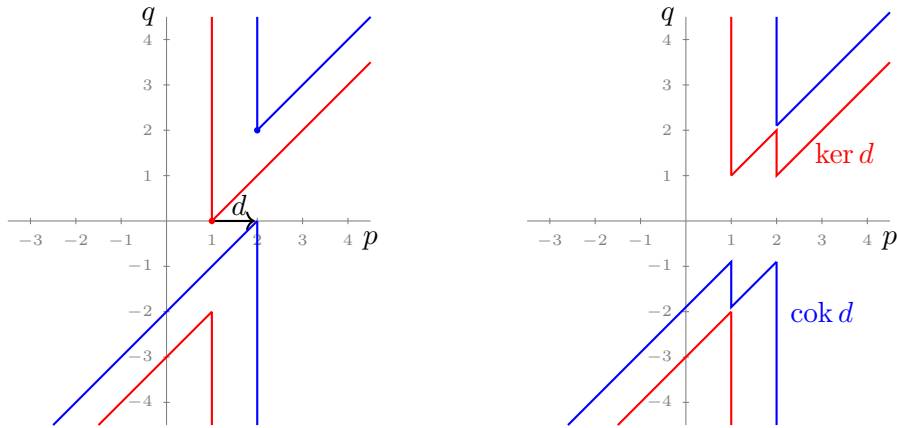

FIGURE 6.2 Differential in a long exact sequence for $\tilde{H}^{*,*}(\mathbb{R}P_{tw}^2)$.

The only possible differential, determined by its image on the generator of the free module $\tilde{H}^{*,*}(S^{1,0}) \cong \Sigma^{1,0}\mathbb{M}_2$, must be nonzero by Lemma 6.1.1. This is because the quotient $\mathbb{R}P_{tw}^2/C_2$ is the cone on S^1 , which is contractible. The \mathbb{M}_2 -modules $\text{cok } d$ and $\text{ker } d$ resulting from this differential are depicted on the right side of Figure 6.2. Even though we know this differential, computing $\tilde{H}^{*,*}(\mathbb{R}P_{tw}^2)$ requires solving the extension problem in the short exact sequence

$$0 \rightarrow \text{cok } d \rightarrow \tilde{H}^{*,*}(\mathbb{R}P_{tw}^2) \rightarrow \text{ker } d \rightarrow 0.$$

One might hope for the short exact sequence to be split, but this turns out not to be the case.

From Theorem 5.0.1, the cohomology of $\mathbb{R}P_{tw}^2$ contains only shifted copies of \mathbb{M}_2 and \mathbb{A}_n . Looking at the modules $\text{cok } d$ and $\text{ker } d$ we see a gap. Along the p -axis the cohomology is trivial because the quotient $\mathbb{R}P_{tw}^2/C_2$ is contractible. Since \mathbb{A}_n has no gaps, the cohomology of $\mathbb{R}P_{tw}^2$ must consist only of copies of \mathbb{M}_2 . Finally by inspecting the rank in each bidegree, we see that $\tilde{H}^{*,*}(\mathbb{R}P_{tw}^2) \cong \Sigma^{1,1}\mathbb{M}_2 \oplus \Sigma^{2,1}\mathbb{M}_2$ as shown in Figure 6.3.

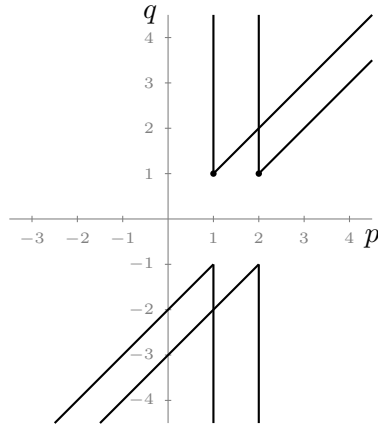

FIGURE 6.3 Cohomology of $\mathbb{R}P_{tw}^2$.

In general, many \mathbb{M}_2 -modules arise as kernels and cokernels of differentials in spectral sequence or long exact sequence computations. One advantage of our main theorem is to resolve the associated extension problems. In Example 6.1.2 we saw a differential between two copies of \mathbb{M}_2 leading to the \mathbb{M}_2 -modules $\text{cok } d$ and $\text{ker } d$ depicted in Figure 6.2 and discovered the result must consist only of copies of \mathbb{M}_2 . Here the generator of one copy of \mathbb{M}_2 hit an element of the lower cone of the other \mathbb{M}_2 and the result was two copies of \mathbb{M}_2 shifted vertically from their original position as shown in Figure 6.3. Indeed, any differential from the generator of a copy of \mathbb{M}_2 to the lower cone of another copy gives rise to a similar result, as seen in [7].

We present a few more examples of differentials to give an idea of the range of possible \mathbb{M}_2 -modules one might encounter in computations. These examples also illustrate how our main theorem can be used.

Example 6.1.3. In Figure 6.4 we see a differential where the generator of one copy of \mathbb{M}_2 hits an element in the upper cone of another, rather than the lower cone. This differential d is depicted on the left side of Figure 6.4 with $\text{cok } d$ and $\text{ker } d$

pictured on the right. Every element here is τ -torsion but both \mathbb{M}_2 and \mathbb{A}_n have elements that are not τ -torsion. This means the usual extension problem cannot be solved with any number of copies of \mathbb{M}_2 or \mathbb{A}_n . As a consequence of Theorem 5.0.1, a differential like this one is impossible when computing the cohomology of a finite C_2 -CW complex.

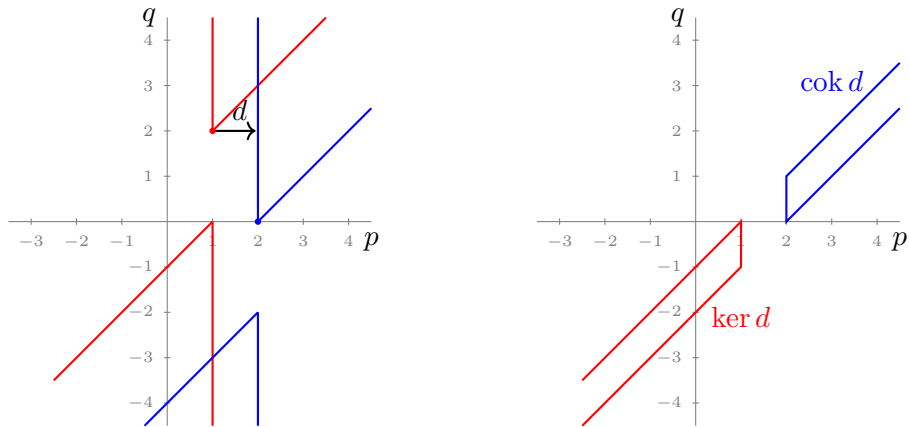

FIGURE 6.4 Differential to upper cone of \mathbb{M}_2 .

Warning 6.1.4. It is in fact possible to have a nonzero differential into the upper cone when computing the cohomology of a space. For example, one could have an isomorphism between two copies of \mathbb{M}_2 . One could also have the generator of one copy hit ρ^n times the generator of the other copy. Neither of these contradict our main theorem. The next example demonstrates the latter type of differential.

Example 6.1.5. Consider the space $X = S^{2,2} \cup I_{\text{triv}}$ where a line segment with the trivial action connects the north and south poles of $S^{2,2}$. There is a cofiber sequence $S^{2,2} \hookrightarrow X \rightarrow S^{1,0}$ and the differential in the long exact sequence associated to this cofiber sequence is depicted in Figure 6.5. This differential must be nonzero by Lemma 4.0.3 because the fixed-set of X is contractible so $\rho^{-1}\tilde{H}^{*,*}(X) \equiv 0$. Here the generator of one copy of \mathbb{M}_2 hits ρ^2 times the generator of the other copy. As a

result of the main theorem, the associated extension problem in this example must be solved by $\Sigma^{1,0}\mathbb{A}_1$.

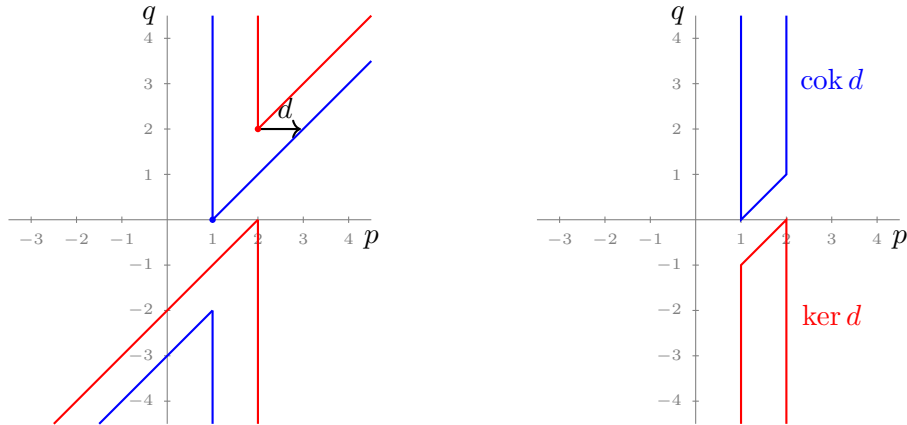

FIGURE 6.5 Another differential to an upper cone of \mathbb{M}_2 .

Example 6.1.6. Another example of a differential d that arises in computations is from the generator of a copy of \mathbb{M}_2 to a shifted copy of \mathbb{A}_0 . As a trivial example, one could compute $\tilde{H}^{*,*}(S^{2,1})$ via the cofiber sequence $S^{1,0} \hookrightarrow S^{2,1} \rightarrow C_{2+} \wedge S^2$ as depicted in Figure 6.6. The differential here is nontrivial because the quotient $S^{2,1}/C_2$ is contractible. Counting the rank in each bidegree, Theorem 5.0.1 implies the extension problem in the associated short exact sequence

$$0 \rightarrow \text{cok } d \rightarrow \tilde{H}^{*,*}(S^{2,1}) \rightarrow \text{ker } d \rightarrow 0$$

must be solved by $\tilde{H}^{*,*}(S^{2,1}) \cong \Sigma^{2,1}\mathbb{M}_2$, which agrees with the suspension isomorphism.

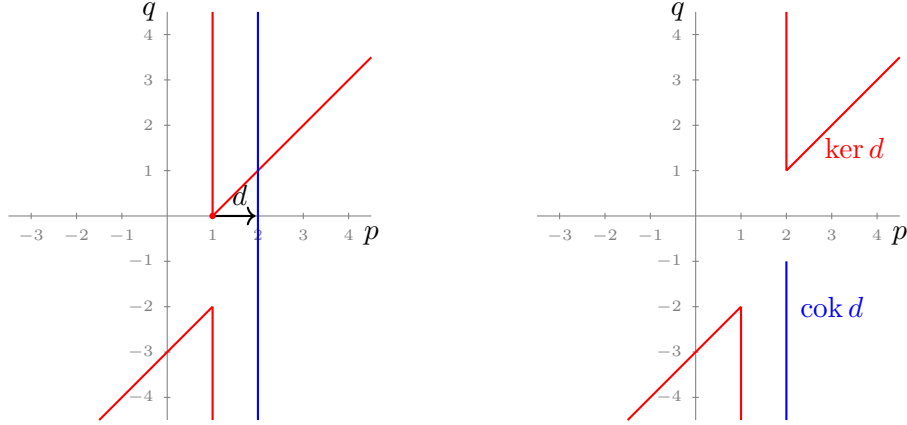

FIGURE 6.6 Differential to \mathbb{A}_0 .

6.2. Homology

We obtain a structure theorem for $RO(C_2)$ -graded homology as an immediate consequence of our main theorem. Since \mathbb{M}_2 is self-injective, we can define an $RO(C_2)$ -graded homology theory via graded \mathbb{M}_2 -module maps

$$H_{a,b}(X) = \text{Hom}_{\mathbb{M}_2}(H^{*,*}(X), \Sigma^{a,b}\mathbb{M}_2).$$

One can check this homology theory agrees with the usual $RO(C_2)$ -graded Bredon homology with \mathbb{F}_2 -coefficients on each orbit. We write $\mathbb{M}_2^* = \text{Hom}_{\mathbb{M}_2}(\mathbb{M}_2, \Sigma^{*,*}\mathbb{M}_2)$ for the homology of a point and $\mathbb{A}_n^* = \text{Hom}_{\mathbb{M}_2}(\mathbb{A}_n, \Sigma^{*,*}\mathbb{M}_2)$ for the homology of S_a^n . Then we obtain a decomposition of the homology of any finite C_2 -CW complex as an \mathbb{M}_2 -module given by

$$H_{*,*}(X) \cong (\oplus_i \Sigma^{p_i, q_i} \mathbb{M}_2^*) \oplus (\oplus_j \Sigma^{r_j, 0} \mathbb{A}_{n_j}^*).$$

6.3. Borel Cohomology

Another application of the main theorem can be observed via Borel equivariant cohomology. For a C_2 -space X , by $H_{Bor}^*(X)$ we mean the Borel equivariant cohomology of X with \mathbb{F}_2 -coefficients. This can be computed as $H_{sing}^*(X \times_{C_2} EC_2) \cong H_{sing}^*(X \times_{C_2} S_a^\infty)$ using S_a^∞ as a model for EC_2 .

Using the fiber bundle map $X \times_{C_2} EC_2 \rightarrow BC_2$, $H_{Bor}^*(X)$ is a module over the graded \mathbb{F}_2 -algebra $H_{sing}^*(BC_2) = H_{sing}^*(\mathbb{R}P^\infty) \cong \mathbb{F}_2[x]$, where x has degree 1. If X is a finite C_2 -CW complex, $H_{Bor}^*(X)$ is a finitely generated module over a graded PID and there is a decomposition

$$H_{Bor}^*(X) \cong (\oplus_k \Sigma^{a_k} \mathbb{F}_2[x]) \oplus (\oplus_\ell \Sigma^{b_\ell} \mathbb{F}_2[x]/(x^{n_\ell}))$$

as a graded $\mathbb{F}_2[x]$ -module.

The following result relating the τ -localization of the $RO(C_2)$ -graded cohomology with Borel cohomology is well known.

Lemma 6.3.1. *For any finite C_2 -CW complex X , identifying x with $\tau^{-1}\rho$, we have the following isomorphism of $\mathbb{F}_2[x]$ -modules*

$$(\tau^{-1}H)^{*,0}(X) \cong H_{Bor}^*(X).$$

Applying τ -localization to our main theorem we have

$$\begin{aligned} \tau^{-1}H^{*,*}(X) &\cong \tau^{-1} \left((\oplus_i \Sigma^{p_i, q_i} \mathbb{M}_2) \oplus (\oplus_j \Sigma^{r_j, 0} \mathbb{A}_{n_j}) \right) \\ &\cong (\oplus_i \Sigma^{p_i, 0} \mathbb{A}_\infty) \oplus (\oplus_j \Sigma^{r_j, 0} \mathbb{A}_{n_j}). \end{aligned}$$

So identifying x with $\tau^{-1}\rho$, on the p -axis we have

$$(\tau^{-1}H)^{*,0}(X) \cong (\oplus_i \Sigma^{p_i} \mathbb{F}_2[x]) \oplus (\oplus_j \Sigma^{r_j} \mathbb{F}_2[x]/(x^{n_j+1})).$$

Now compare this with Borel cohomology using Lemma 6.3.1 and the decomposition of $H_{Bor}^*(X)$ as a $\mathbb{F}_2[x]$ -module. We see the torsion components of Borel cohomology correspond precisely to the shifted copies of \mathbb{A}_{n_j} in $H^{*,*}(X)$, and the free components correspond to shifted copies of \mathbb{M}_2 . In particular, if we know the Borel cohomology of a finite C_2 -CW complex, to compute $RO(C_2)$ -graded cohomology we only need to determine the weight of each copy of \mathbb{M}_2 . This is often nontrivial, though.

APPENDIX A

INJECTIVITY

The purpose of this section is to prove that \mathbb{M}_2 is self-injective. The proof will use a graded version of Baer's criterion (Proposition 9.3.6 in [2]). According to Baer's criterion, \mathbb{M}_2 is injective if and only if for every graded ideal $J \subseteq \mathbb{M}_2$, any map $f : \Sigma^{p,q}J \rightarrow \mathbb{M}_2$ extends to a map $\bar{f} : \Sigma^{p,q}\mathbb{M}_2 \rightarrow \mathbb{M}_2$ as in the diagram below.

$$\begin{array}{ccc}
 \Sigma^{p,q}J & \xrightarrow{f} & \mathbb{M}_2 \\
 \downarrow & \nearrow \bar{f} & \\
 \Sigma^{p,q}\mathbb{M}_2 & &
 \end{array}$$

Equivalently, it suffices to show that for every map $f : \Sigma^{p,q}J \rightarrow \mathbb{M}_2$ there is an element $\lambda \in \mathbb{M}_2$ such that $f(x) = \lambda x$ for all $x \in J$.

In order to show that Baer's criterion is satisfied, we first need to investigate ideals of \mathbb{M}_2 . A few examples are shown in Figure A.1. The first ideal pictured is generated by three elements in the upper cone and contains the entire lower cone. The second ideal is generated by 3 elements in the lower cone. The last two ideals shown here are infinitely generated by elements in the lower cone.

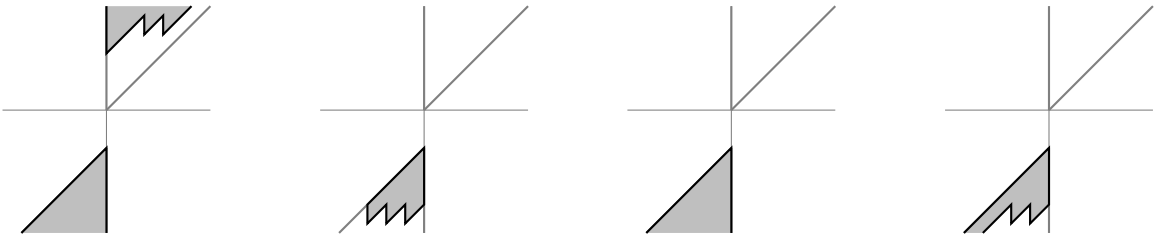

FIGURE A.1 Some ideals in \mathbb{M}_2 .

For our purposes it will be useful to classify graded ideals of \mathbb{M}_2 as one of two types. We use the notation $J^+ = \mathbb{M}_2^+ \cap J$ and $J^- = \mathbb{M}_2^- \cap J$.

Lemma A.0.1. *Every graded ideal $J \subseteq \mathbb{M}_2$ is one of the following two types,*

I. J is finitely generated by homogeneous elements x_1, \dots, x_n with each $x_i \in \mathbb{M}_2^+$ and $J^- = \mathbb{M}_2^-$; or

II. $J^+ = 0$.

Proof. Observe that if J contains a nonzero homogeneous element of \mathbb{M}_2^+ , i.e. there exists $x = \rho^m \tau^n \in J$ for some $m, n \geq 0$, then $\mathbb{M}_2^- \subseteq J$. For example, $\theta \in J$ because

$$\theta = \frac{\theta}{\rho^m \tau^n} \cdot \rho^m \tau^n = \frac{\theta}{\rho^m \tau^n} \cdot x \in J.$$

More generally, for any $a, b \geq 0$

$$\frac{\theta}{\rho^a \tau^b} = \frac{\theta}{\rho^{m+a} \tau^{n+b}} \cdot \rho^m \tau^n = \frac{\theta}{\rho^{m+a} \tau^{n+b}} \cdot x \in J.$$

So indeed $\mathbb{M}_2^- \subseteq J$. Since $\mathbb{M}_2^+ \cong \mathbb{F}_2[\rho, \tau]$ is polynomial, any graded ideal of this form is finitely generated by some number of homogeneous elements in \mathbb{M}_2^+ .

Alternatively, if $J^+ = 0$, then J only contains elements of \mathbb{M}_2^- . We have seen such an ideal may be finitely generated or infinitely generated. In either case we call J an ideal of type II. □

Returning to Figure A.1, we see the first ideal pictured is type I and the rest are type II. Next we will describe all possible nonzero maps $f : \Sigma^{p,q} J \rightarrow \mathbb{M}_2$. We will see there are not really any interesting maps. Any such f is completely determined by the bidegree (p, q) of the suspension.

Lemma A.0.2. *Let $J \subseteq \mathbb{M}_2$ be a graded ideal and $f : \Sigma^{p,q} J \rightarrow \mathbb{M}_2$ be a nontrivial map. Then exactly one of the following holds,*

I. J is type I and either

(i) $f(\rho^m \tau^n) = \rho^a \tau^b$ for some $m, n \geq 0$ and $a \geq m, b \geq n$; or

(ii) $f(\rho^m \tau^n) = \frac{\theta}{\rho^a \tau^b}$ for some $m, n \geq 0$ and $a, b \geq 0$.

II. J is type II and $f\left(\frac{\theta}{\rho^m \tau^n}\right) = \frac{\theta}{\rho^a \tau^b}$ for some $m, n \geq 0$ and $m \geq a \geq 0, n \geq b \geq 0$.

Proof. We will consider each type of ideal separately.

I. We begin by assuming J is type I so that J^+ is nontrivial and $J^- = \mathbb{M}_2^-$. If

$f(J^+) = 0$ then $f(\rho^m \tau^n) = 0$ for all $\rho^m \tau^n \in J^+$. But then for any $a, b \geq 0$

$$f\left(\frac{\theta}{\rho^a \tau^b}\right) = f\left(\frac{\theta}{\rho^{a+m} \tau^{b+n}} \cdot \rho^m \tau^n\right) = \frac{\theta}{\rho^{a+m} \tau^{b+n}} \cdot f(\rho^m \tau^n) = 0.$$

So we also have $f(J^-) = 0$, contradicting that f is nontrivial. Hence there must be some $m, n \geq 0$ such that $\rho^m \tau^n \in J^+$ and $f(\rho^m \tau^n) \neq 0$. Now there are two cases, either $f(\rho^m \tau^n) \in \mathbb{M}_2^+$ or $f(\rho^m \tau^n) \in \mathbb{M}_2^-$.

(i) Suppose $f(\rho^m \tau^n) \in \mathbb{M}_2^+$ so that $f(\rho^m \tau^n) = \rho^a \tau^b$ for some $a, b \geq 0$.

We just need to show that $a \geq m$ and $b \geq n$. This follows immediately because if either $a < m$ or $b < n$ then

$$0 = f(0) = f\left(\frac{\theta}{\rho^a \tau^b} \cdot \rho^m \tau^n\right) = \frac{\theta}{\rho^a \tau^b} \cdot f(\rho^m \tau^n) = \theta$$

in \mathbb{M}_2 , a contradiction.

(ii) Now suppose $f(\rho^m \tau^n) \in \mathbb{M}_2^-$. Then $f(\rho^m \tau^n) = \frac{\theta}{\rho^a \tau^b}$ for some $a, b \geq 0$.

There is no further restriction on the values of a and b in this case.

II. Next we consider an ideal of type II, so that $J^+ = 0$. Since f is nontrivial,

there must be some $m, n \geq 0$ with $f\left(\frac{\theta}{\rho^m \tau^n}\right) \neq 0$. It is not possible that

$f\left(\frac{\theta}{\rho^m \tau^n}\right) \in \mathbb{M}_2^+$ because if $f\left(\frac{\theta}{\rho^m \tau^n}\right) = \rho^a \tau^b$ for some $a, b \geq 0$, then we get an immediate contradiction

$$0 = f\left(\rho^{m+1} \tau^{n+1} \cdot \frac{\theta}{\rho^m \tau^n}\right) = \rho^{m+1} \tau^{n+1} \cdot f\left(\frac{\theta}{\rho^m \tau^n}\right) = \rho^{a+m+1} \tau^{b+n+1}.$$

So it must be the case that $f\left(\frac{\theta}{\rho^m \tau^n}\right) \in \mathbb{M}_2^-$. Then $f\left(\frac{\theta}{\rho^m \tau^n}\right) = \frac{\theta}{\rho^a \tau^b}$ for some $m, n \geq 0$ and $a, b \geq 0$. It remains to show that $m \geq a$ and that $n \geq b$. If either $m < a$ or $n < b$, then again we get a contradiction because

$$0 = f(0) = f\left(\rho^a \tau^b \cdot \frac{\theta}{\rho^m \tau^n}\right) = \rho^a \tau^b \cdot f\left(\frac{\theta}{\rho^m \tau^n}\right) = \rho^a \tau^b \cdot \frac{\theta}{\rho^a \tau^b} = \theta.$$

This completes the proof. □

It appears we have not fully described each map in the previous lemma since we only described the image of a single element. The following lemma implies that any map of a graded ideal $f : \Sigma^{p,q} J \rightarrow \mathbb{M}_2$ is completely determined by a single nonzero element in its image. Hence, Lemma A.0.2 does indeed classify maps of graded ideals to \mathbb{M}_2 .

Lemma A.0.3. *Let $J \subseteq \mathbb{M}_2$ be a graded ideal with two maps $f, g : \Sigma^{p,q} J \rightarrow \mathbb{M}_2$.*

If $x \in J$ is a nonzero homogeneous element with $f(x) \neq 0$ and $f(x) = g(x)$, then $f = g$.

Proof. We begin by observing that \mathbb{M}_2 has at most one nonzero element in any given bidegree. This implies that if m, x , and y are homogeneous elements of \mathbb{M}_2 with $mx \neq 0$ and $mx = my$, then $x = y$. We call this property P .

Let $A = \{y \in J \mid f(y) = g(y)\}$. Our goal is to show that $A = J$. Notice that $A \subseteq J$ is a submodule because f and g are both \mathbb{M}_2 -module maps. Furthermore, if

$m \in \mathbb{M}_2$ and $y \in J$ are homogeneous elements with $my \in A$ and $f(my) \neq 0$, then $y \in A$. This is because

$$mf(y) = f(my) = g(my) = mg(y)$$

and by property P we must have $f(y) = g(y)$. We now proceed with several cases, considering each type of ideal separately.

I. Suppose J is type I. Then J is finitely generated by some elements of \mathbb{M}_2^+ and $J^- = \mathbb{M}_2^-$.

(a) Suppose $x \in J^+$. The ideal generated by x is type I so it contains \mathbb{M}_2^- .

Since A is a submodule and x is in A by assumption, $J^- = \mathbb{M}_2^- \subseteq A$.

Consider a homogeneous element $y \in J - A$, which would have to be in J^+ . Set $z = \text{lcm}(x, y)$ so that $z = \rho^a \tau^b y$ for some $a, b \geq 0$. Either $f(x) \in \mathbb{M}_2^+$ or $f(x) \in \mathbb{M}_2^-$. Using z , we can show in either case that in fact y must be in A .

i. Suppose $f(x) \in \mathbb{M}_2^+$. Since $z \in A$, $f(z) = g(z)$. There is no ρ - or τ -torsion in \mathbb{M}_2^+ so $f(z) \neq 0$. By property P we see that $f(y) = g(y)$ and indeed $y \in A$.

ii. Suppose $f(x) \in \mathbb{M}_2^-$. Again $f(z) = g(z)$ since $z \in A$. It is possible that $f(z) = 0$ for degree reasons, in which case $f(y) = g(y) = 0$ for degree reasons as well. Otherwise, $f(z) \neq 0$ and again by property P we have $f(y) = g(y)$.

(b) Now suppose that $x \in J^-$ (though we still assume J is type I). Then we can write $x = mx'$ for some $x' \in J^+$ and $m \in \mathbb{M}_2^-$. As usual, since $f(x) = f(mx') \neq 0$ and $mx' \in A$, property P implies that $f(x') = g(x')$.

Now x' satisfies case (a) above. From the previous argument we have that $A = J$.

II. Suppose J is type II. Then $x \in J^-$ because $J^+ = 0$. Suppose $y \in J - A$ is a nonzero homogeneous element. Set $z = \text{lcm}(x, y)$ so that $z = \rho^a \tau^b y$ for some $a, b \geq 0$ and repeat the argument in case (a)(ii) above. From the proof of Lemma A.0.2 it is not possible that $f(x) \in \mathbb{M}_2^+$, so we are done.

This completes the proof that $A = J$ and so $f = g$. □

We are now ready to prove that \mathbb{M}_2 is self-injective. The following proposition also appears as Proposition 4.0.2.

Proposition A.0.4. *The regular module \mathbb{M}_2 is injective as an \mathbb{M}_2 -module.*

Proof. From the discussion of the graded version of Baer's criterion above, it suffices to show that for any graded ideal $J \subseteq \mathbb{M}_2$ and any map $f : \Sigma^{p,q} J \rightarrow \mathbb{M}_2$, there is an element $\lambda \in \mathbb{M}_2$ such that $f(x) = \lambda x$ for all $x \in J$. Let J be an ideal and $f : \Sigma^{p,q} J \rightarrow \mathbb{M}_2$. Of course, if $f = 0$ then we can take $\lambda = 0$, so assume $f \neq 0$. Every nontrivial map f satisfies one of the cases described in Lemma A.0.2, so we consider each separately.

I. Assume the ideal $J \subseteq \mathbb{M}_2$ is type I so that J^+ contains some elements of \mathbb{M}_2^+ and $J^- = \mathbb{M}_2^-$.

(i) Suppose $f(\rho^m \tau^n) = \rho^a \tau^b$ for some $m, n \geq 0$ and $a \geq m, b \geq n$. Define $g : \Sigma^{p,q} J \rightarrow \mathbb{M}_2$ to be multiplication by $\lambda = \rho^{a-m} \tau^{b-n}$ so we have $g(x) = \rho^{a-m} \tau^{b-n} \cdot x$ for all $x \in J$. Then $f(\rho^m \tau^n) = g(\rho^m \tau^n)$ and by uniqueness from Lemma A.0.3 we have that $f = g$.

(ii) Suppose $f(\rho^m \tau^n) = \frac{\theta}{\rho^a \tau^b}$ for some $m, n \geq 0$ and $a, b \geq 0$. Now we define $g : \Sigma^{p,q} J \rightarrow \mathbb{M}_2$ to be multiplication by $\lambda = \frac{\theta}{\rho^{a+m} \tau^{b+n}}$. Again $f(\rho^m \tau^n) = g(\rho^m \tau^n)$ and by uniqueness $f = g$.

II. Finally assume the ideal $J \subseteq \mathbb{M}_2$ is type II so that $J^+ = 0$. We know in this case $f\left(\frac{\theta}{\rho^m \tau^n}\right) = \frac{\theta}{\rho^a \tau^b}$ for some $m, n \geq 0$ and $m \geq a \geq 0, n \geq b \geq 0$. Now f agrees with multiplication by $\lambda = \rho^{m-a} \tau^{n-b}$.

We have shown every map $f : \Sigma^{p,q} J \rightarrow \mathbb{M}_2$ is multiplication by some element $\lambda \in \mathbb{M}_2$, which completes the proof that the regular module is injective. □

APPENDIX B

MOTIVATION

The following computations of $RO(C_2)$ -graded cohomology for the torus were joint work with Eric Hogle and served as part of the motivation for the main theorem. There are six C_2 -actions on the torus $T = S^1 \times S^1$ up to equivariant isomorphism (see [4]). In Figure B.1 we see the cohomology of the torus T_{triv} with the trivial action, T_{refl} with action given by reflection in either the horizontal or vertical plane, T_{spit} with action given by rotation about an axis which meets the torus at four points, T_{rot} with the free rotation action, T_{anti} with the antipodal action, and finally T_{swap} with the action that swaps the two generators of $H_{\text{sing}}^1(T)$.

We see here the cohomology of each torus, as an \mathbb{M}_2 -module, consists only of some number of shifted copies of the cohomology of a point and some number of shifted copies of the cohomologies of antipodal spheres.¹

¹Although T_{rot} and T_{anti} have the same cohomology in \mathbb{F}_2 -coefficients, they are not isomorphic C_2 -spaces as $H^{*,*}(T_{\text{rot}}; \mathbb{Z}) \not\cong H^{*,*}(T_{\text{anti}}; \mathbb{Z})$.

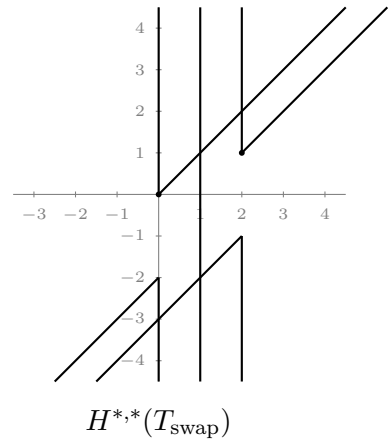
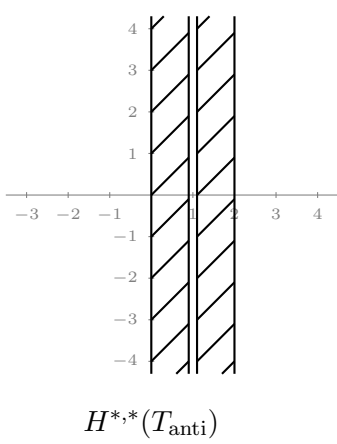
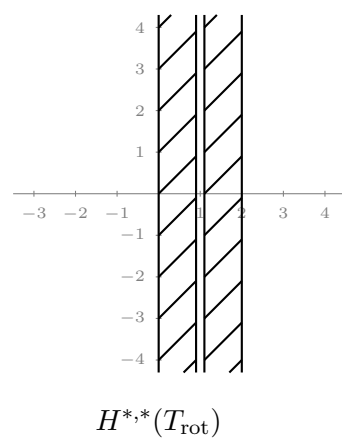
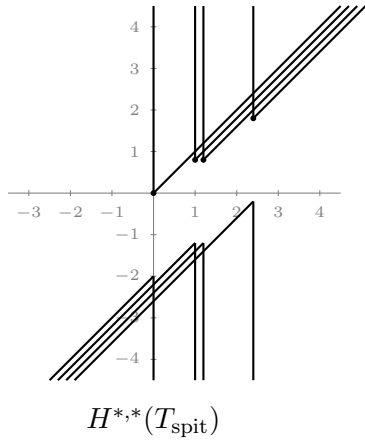
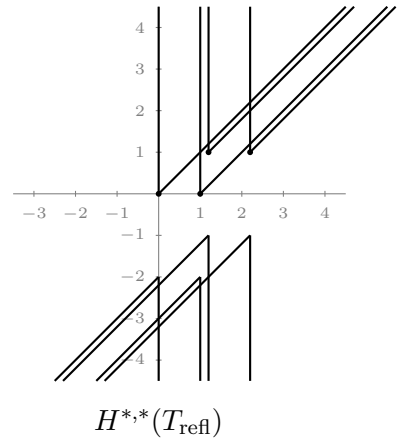
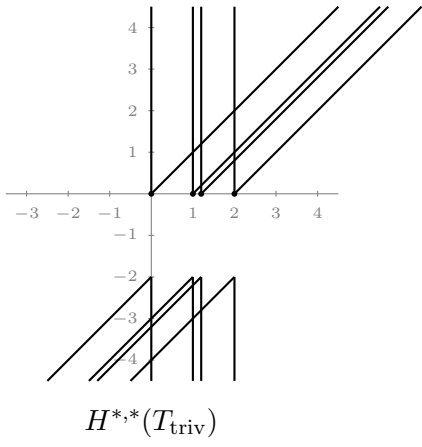

FIGURE B.1 Cohomology of C_2 -actions on a torus.

REFERENCES CITED

- [1] Shôrô Araki and Mitutaka Murayama, *τ -cohomology theories*, Japan. J. Math. (N.S.) **4** (1978), no. 2, 363–416. MR 528864
- [2] Paul E. Bland, *Rings and their modules*, Walter de Gruyter & Co., Berlin, 2011. MR 2777416
- [3] Pedro F. dos Santos, *A note on the equivariant Dold-Thom theorem*, J. Pure Appl. Algebra **183** (2003), no. 1-3, 299–312. MR 1992051
- [4] Daniel Dugger, *Involutions on surfaces*, ArXiv preprint (2016).
- [5] Kevin K. Ferland and L. Gaunce Lewis, Jr., *The $RO(G)$ -graded equivariant ordinary homology of G -cell complexes with even-dimensional cells for $G = \mathbb{Z}/p$* , Mem. Amer. Math. Soc. **167** (2004), no. 794, viii+129. MR 2025457
- [6] Daniel C. Isaksen, *Stable stems*, ArXiv preprint (2014).
- [7] William C. Kronholm, *A freeness theorem for $RO(\mathbb{Z}/2)$ -graded cohomology*, Topology Appl. **157** (2010), no. 5, 902–915. MR 2593703
- [8] J. P. May, *Equivariant homotopy and cohomology theory*, CBMS Regional Conference Series in Mathematics, vol. 91, Published for the Conference Board of the Mathematical Sciences, Washington, DC; by the American Mathematical Society, Providence, RI, 1996, With contributions by M. Cole, G. Comezana, S. Costenoble, A. D. Elmendorf, J. P. C. Greenlees, L. G. Lewis, Jr., R. J. Piacenza, G. Triantafillou, and S. Waner. MR 1413302
- [9] Megan Elizabeth Shulman, *Equivariant local coefficients and the $RO(G)$ -graded cohomology of classifying spaces*, ProQuest LLC, Ann Arbor, MI, 2010, Thesis (Ph.D.)—The University of Chicago. MR 2941379