



Timber Tectonics: Building for the Circular Economy

Elisia Alampi

Report Author • School of Architecture & Environment

Nancy Cheng

Associate Professor • School of Architecture & Environment

Mariapaola Riggio

Associate Professor • Wood Science & Engineering, Oregon State University

FALL 2023

SALEM

ARCH 484/584: TIMBER TECTONICS IN THE DIGITAL AGE | COLLEGE OF DESIGN



Acknowledgements

- This effort is partially supported by a grant from the U.S. Department of Agriculture's Agricultural Research Service (USDA ARS) [Agreement No. 58-0204-2-143].
- Tallwood Design Institute (TDI) supported this inquiry into Building for the Circular Economy with reusable, reconfigurable components.
- TDI staff Phil Mann, Mark Gerig, and Byrne Miyamoto provided Computer Numerical Control (CNC) routing and construction support.
- UO College of Design Fabrication manager Tom Coates worked patiently with the students to guide successful CNC cutting of multiple prototypes in Eugene.
- UO Sustainable City Year Program funded crucial expenditures, connected us to the City of Salem's Strategic Initiatives Manager Courtney Knox Busch and Parks Planning Director Robert Romanek, leading to the participation of Engineers Aaron Kimsey and Ryan McGraw, and Salem Parks and Recreation Advisory Board and Highland Neighborhood resident stakeholders.
- Roseburg Forest Products contributed the plywood used in the project.
- The OSU Department of Wood Science supported the studio by allowing the assistance of OSU PhD student Alireza Yari.
- The UO Department of Architecture supported the studio with a research grant that allowed hiring of B.Arch. student Grayson Wright to assist the class.
- The UO Women of Color Summer Writing Fellowship provided funds to hire research assistant Josh Weber for initial explorations, which were done with the help of Justin Tuttle, UO Portland Workshop Technician.

This report represents original student work and recommendations prepared by students in the University of Oregon's Sustainable City Year Program for the City of Salem. Text and images contained in this report may not be used without permission from the University of Oregon.

*Cover Image Credit:
Charlotte Kamman*

Contents

4	About SCI
4	About SCYP
5	About City of Salem
6	Course Participants
7	Course Description
7	Executive Summary
8	Introduction
9	The Site
10	Team Designs
16	Class Initial Design
19	Structural Analysis
21	Design Refinement
25	Assembly
29	Conclusion
32	Appendix A: Amended Final Presentation PDF
57	Appendix B: Structural Design Report
85	Appendix C: Construction and Deconstruction Manual

About SCI

The Sustainable Cities Institute (SCI) is an applied think tank focusing on sustainability and cities through applied research, teaching, and community partnerships. We work across disciplines that match the complexity of cities to address sustainability challenges, from regional planning to building design and from enhancing engagement of diverse communities to understanding the impacts on municipal budgets from disruptive technologies and many issues in between.

SCI focuses on sustainability-based research and teaching opportunities through two primary efforts:

1. Our Sustainable City Year Program (SCYP), a massively scaled university-community partnership program that matches the resources of the University with one Oregon community each year to help advance that community's sustainability goals; and

2. Our Urbanism Next Center, which focuses on how autonomous vehicles, e-commerce, and the sharing economy will impact the form and function of cities.

In all cases, we share our expertise and experiences with scholars, policymakers, community leaders, and project partners. We further extend our impact via an annual Expert-in-Residence Program, SCI China visiting scholars program, study abroad course on redesigning cities for people on bicycle, and through our co-leadership of the Educational Partnerships for Innovation in Communities Network (EPIC-N), which is transferring SCYP to universities and communities across the globe. Our work connects student passion, faculty experience, and community needs to produce innovative, tangible solutions for the creation of a sustainable society.

About SCYP

The Sustainable City Year Program (SCYP) is a yearlong partnership between SCI and a partner in Oregon, in which students and faculty in courses from across the university collaborate with a public entity on sustainability and livability projects. SCYP faculty and students work in collaboration with staff from the partner agency through a variety of studio projects and service-learning courses to

provide students with real-world projects to investigate. Students bring energy, enthusiasm, and innovative approaches to difficult, persistent problems. SCYP's primary value derives from collaborations that result in on-the-ground impact and expanded conversations for a community ready to transition to a more sustainable and livable future.

About City of Salem

The City of Salem is Oregon’s second largest city (179,605; 2022) and the State’s capital. A diverse community, Salem has well-established neighborhoods, a family-friendly ambiance, and a small town feel, with easy access to the Willamette riverfront and nearby outdoor recreation, and a variety of cultural opportunities.



The City is known for having one of Oregon’s healthiest historic downtowns, hosts an airport with passenger air service, and is centrally located in the heart of the Willamette Valley, 47 miles south of Portland and an hour from the Cascade Mountains to the east and the ocean beaches to the west.

State government is Salem’s largest employer, followed by the Salem-Keizer School District and Salem Health. The City also serves as a hub for area farming communities and is a major agricultural

food processing center. A plethora of higher education institutions are located in Salem, ranging from public Western Oregon University, private Willamette and Corban universities, and Chemeketa Community College.

Salem is in the midst of sustained, steady growth. As a “full-service” city, it provides residents with services such as police and fire protection, emergency services, sewage collection and treatment, and safe drinking water. Salem also provides planning and permitting to help manage

growth, as well as economic development to support job creation and downtown development. The City also provides 2,338 acres of parks, libraries and educational programs, housing and social services, public spaces, streetscaping, and public art.

Salem's vision is a safe, livable, and sustainable capital city, with a thriving economy and a vibrant community that is welcoming to all. The City's mission is to provide fiscally sustainable and quality services to enrich the lives of present and future residents, protect and enhance the quality of the environment and neighborhoods, and support the vitality

of the economy. The City is in the midst of a variety of planning efforts that will shape its future, ranging from climate action planning and implementation, a transportation system plan update, as well as parks master planning.

This SCYP and City of Salem partnership is possible in part due to support from U.S. Senators Ron Wyden and Jeff Merkley, as well as former Congressman Peter DeFazio, who secured federal funding for SCYP through Congressionally Directed Spending. With additional funding from the city, the partnership will allow UO students and faculty to study and make recommendations on city-identified projects and issues.

Course Participants

ARCHITECTURAL DESIGN

Braden Lawrie
Yasmeen Sundareswaran
Seunghyeon Park
Michelle Jayawickrama

STRUCTURAL DESIGN

Nick Thielsen
Lara Diehm
Jackson Megy
Rory Doerksen

JOINTS AND CONNECTIONS

Charlotte Kamman (UO Project Manager)
Elisia Alampi
Anthony Newton
Harvey Smith

ADDITIONAL COMPONENTS

Nic Ernst
Igor Tiago-Lopes (OSU Project Manager)
Marie Lee

FABRICATION

Jin-wei Chu
Sage Fetkenhour
Bryan Sherlock
Andrew Kesterson

Course Description

ARCH 484/584: TIMBER TECTONICS IN THE DIGITAL AGE

This is a collaborative course between the University of Oregon's Department of Architecture and the Oregon State University's Department of Wood Science and Engineering that focuses on creating novel solutions for a community need. Design projects require comprehensive and integrative study over a wide range of project options to include individual criticism, group discussions, lectures, and seminars by visiting specialists, and public review of projects.

Executive Summary

Exploring innovative kit-of-parts construction methods, our project centers on the adaptable nature of reciprocal frame construction, focusing on sustainable reuse of panel materials such as plywood and Mass Plywood Panels (MPP). The University of Oregon (UO)-Oregon State University (OSU) collaboration generated diverse ideas for a small seasonal pavilion in Salem, Oregon's Highland Park. Following a review, the class united to consolidate the best concepts into a singular project. Operating as one team, the class developed construction

details, prefabricated components, and sequenced on-site assembly. The OSU-UO Tallwood Design Institute's (TDI) Emmerson Lab, UO College of Design's Computer Numerical Control (CNC) machine, and CNC WoodCutters machined trial and final components. Student-led assembly and installation took place in Week 10, with a final review and installation in the Emmerson Lab. The insights of the review, along with the work of the term, culminated with many lessons learned and a new set of guidelines for an outdoor installation in Highland Park.

Introduction

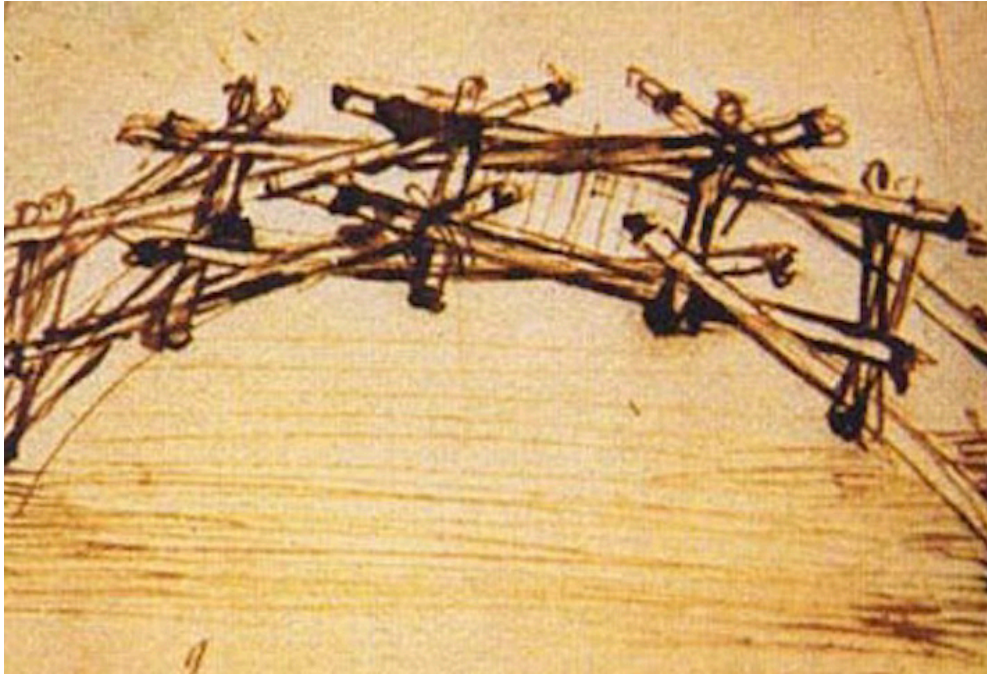

FIG. 1

Reciprocal Frame

Source: *Manuscript by Leonardo da Vinci*

This design studio investigated building methods based on a kit-of-parts concept with a specific focus on the reciprocal frame. Reciprocal frames work by using a system of small members that join to create a larger span than the length of individual members. The frame achieves this because each piece both supports and is supported by another member. Specifications for the project were as listed:

KIT-OF-PART CONSTRAINTS

- The design must incorporate reciprocal frame (RF) systems
- Materials will consist of .75" plywood
- All components may be cut with a CNC router bit perpendicular to the surface of the panels
- The design should minimize component variety
- Roof-like elements should be used to reinforce and protect from rain and sun
- All components may be interconnected using wood-to-wood joints
- All joints should facilitate disassembly and component reuse, demonstrating principles of circular economy

ADDITIONAL CONSTRAINTS FOR THE SELECTED SITE & PROGRAM:

- Material will be 20 sheets of .75" x 48" x 96" plywood
- Shelter footprint must be less than 120 square feet and maximum height 14'
- All components must be fabricated considering the fabrication constraints of the CNC in the TDI's Emmerson Lab
- All components must be transportable in a cargo van with interior dimensions of 11' long, 4'6" wide, and 6'5" high
- The construction needs to discourage climbing or ensure it could be safely climbed
- The report that follows covers the design and construction process taken by the class to create a full scale model of the Highland Arch.

The Site



FIG. 2

Site Plan

Created by Team 4 Student Group

**FIG. 3**

Installation Location

Image by Elisia Alampi

The site chosen for this project is Highland Park, which is located approximately two miles north of the Oregon State Capitol in Salem, Oregon. This park is nestled into a residential area and located directly across from Highland Elementary School. Central to the park is a small playground, which is flanked by a large open field

to the north and mixed tennis and pickleball courts to the south. Along the sidewalk connecting the playground to Columbia St NE is an octagonal concrete platform measuring 18 feet wide. This was designated as the location for the installation of the shading structure.

Team Designs

For the first 5 weeks of the term, students worked in small teams comprised of both OSU and UO students to design versions of the Highland Park pavilion. These designs were presented to a panel of reviewers to discuss the opportunities and potential complications of each. These design options were as follows:

TEAM 1

FIG. 4

Team 1 Design
*Created by Team 1
Student Group*

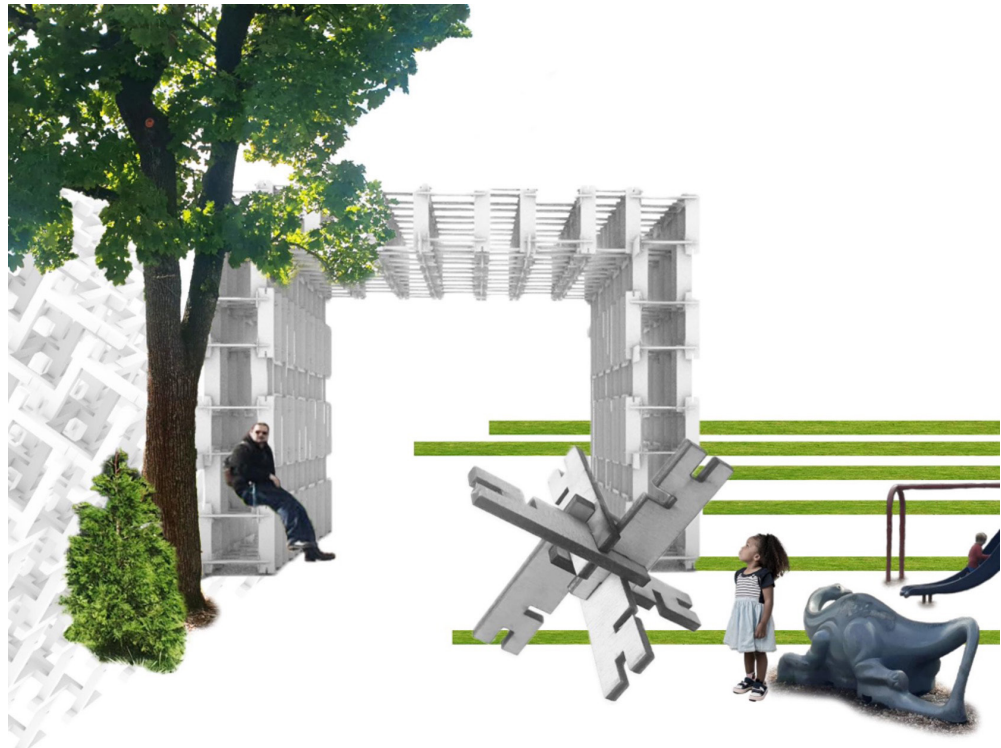

Team 1, comprised of Lara Diehm, Nic Ernst, Marie Lee, and Harvey Smith, explored the use of reciprocal frames volumetrically, drawing inspiration from the Kodama Pavilion designed by Kengo Kuma Architects. They tested many different configurations to understand the capabilities of a volume-based approach and shared each with the group. Positive feedback for Team 1 included:

- Utilizing the same pattern for both the canopy and vertical supports
- Focusing on creating an architecturally compelling design
- Ensuring rigidity in the frame

The design generated concerns about the density of members and how it could be easily climbed.

TEAM 2

Plan

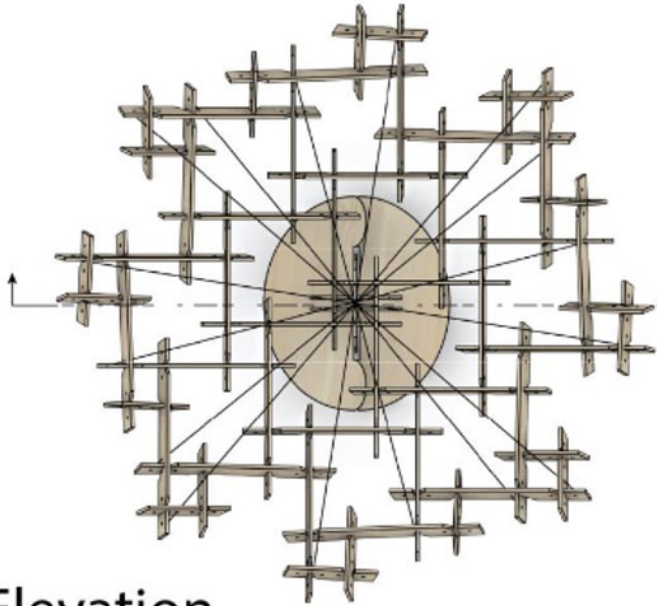

Elevation

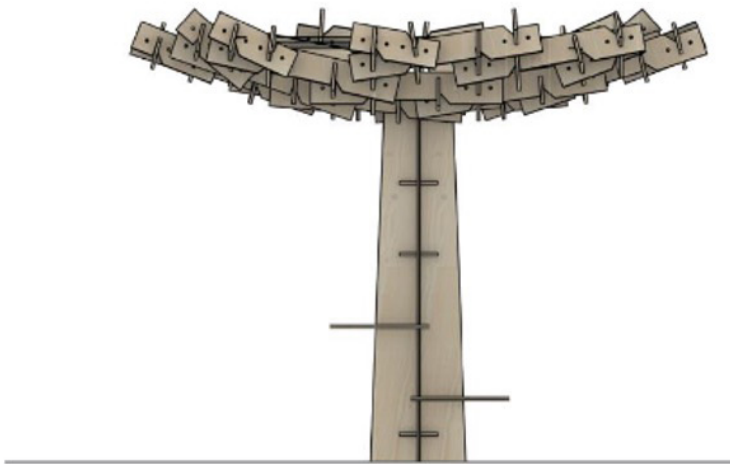

FIG. 5

Team 2 Design

*Created by Team 2
Student Group*

Team 2 was comprised of Jin-Wei Chu, Igor Tiago Lopez, and Anthony Newton. The pattern of their reciprocal frame was inspired by a temporary structure featured during a RAW:almond fine dining festival, and its overall form mimics a tree canopy. Feedback towards the architectural design of the structure was highly positive; reviewers appreciated the care to design

a graceful structure that fit the context of the park. Reviewers also spoke positively on the functional elements integrated into the design such as seating and a tabletop. Structural concerns include concentrated bending stresses on canopy members closest to the column, which could be reduced by deeper members or branching supports, and tension cable placement.

TEAM 3

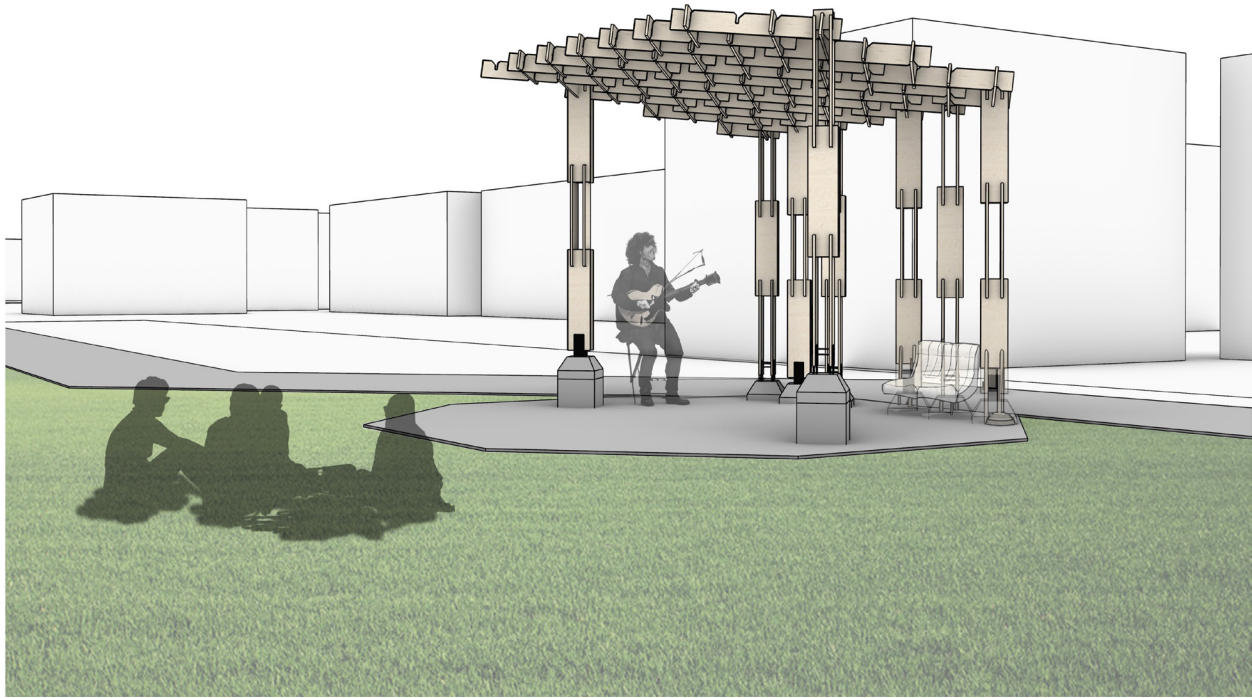

FIG. 6

Team 3 Design

Created by Team 3 Student Group

Team 3 was comprised of Braden Lawrie, Jackson Megy, Bryan Sherlock, and Yasmeen Sundareswaran. After prototyping systems such as Zollinger lamella vault, this team designed a rectangular planar roof tilted towards the public street, supported by custom columns. Reviewers appreciated the

simplicity of the design and care towards detail. They suggested that more similarity of language between the canopy and columns would give the design more unity. Deformation of the front edge could be reduced by moving the two front columns closer together or by adding a secondary beam.

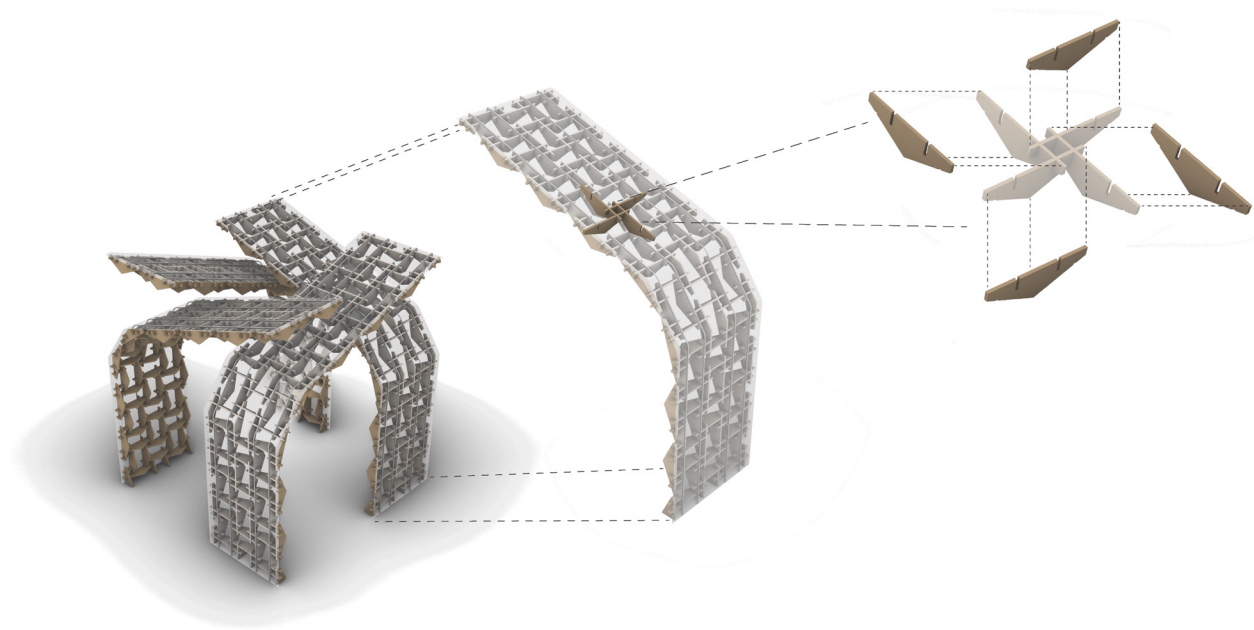
TEAM 4**FIG. 7**

Team 4 Design

Created by Team 4 Student Group

Elisia Alampi, Charlotte Kamman, Andrew Kesterson, and Nick Thielsen comprised Team 4. They drew inspiration from Kyushi Geibun Kan Museum Annex 2 by Kengo Kuma Architects and designed a pinwheel reciprocating structure using triangular pieces. For each curved wall to canopy section, they exposed the longer side of the triangle for flat sections and

exposed the angled corner of the triangle for vertices of a curved profile. Edges of the pattern were locked with mortise and tenon joints. Reviewers commended the way that the individual element shared the form, and the completeness of presentation. There was concern about the stability of the cantilevered design and ease of assembly.

TEAM 5



FIG. 8

Team 5 Design

Created by Team 5 Student Group

Rory Doerksen, Sage Fetkenhour, Michelle Jayawickrama, and Seunghyeon Park comprised Team 5. They built on design research done by Attilio Pizzigoni for the Italian pavilion of the 2010 Shanghai Expo that showed how curved members could generate roof frames of flat, convex, or concave curvature. Creating a script to adjust the curvature, they tested alternative forms and notches

with laser cut models for constructability. Reviewers commended the beauty of the concave to convex pavilion and differed on suggestions for how the canopy should be supported. Some believed the structure should be raised to prevent people from climbing it, while others thought the roof should continue into a vertical to improve its aesthetics.

Class Initial Design

In a post-midterm discussion, the class decided to move forward using Team 4's building system with its unusual and versatile triangular module. All students were invited to propose how the system could be used in a more stable overall form that would meet the Highland Park needs for a performance space and picnic shelter.

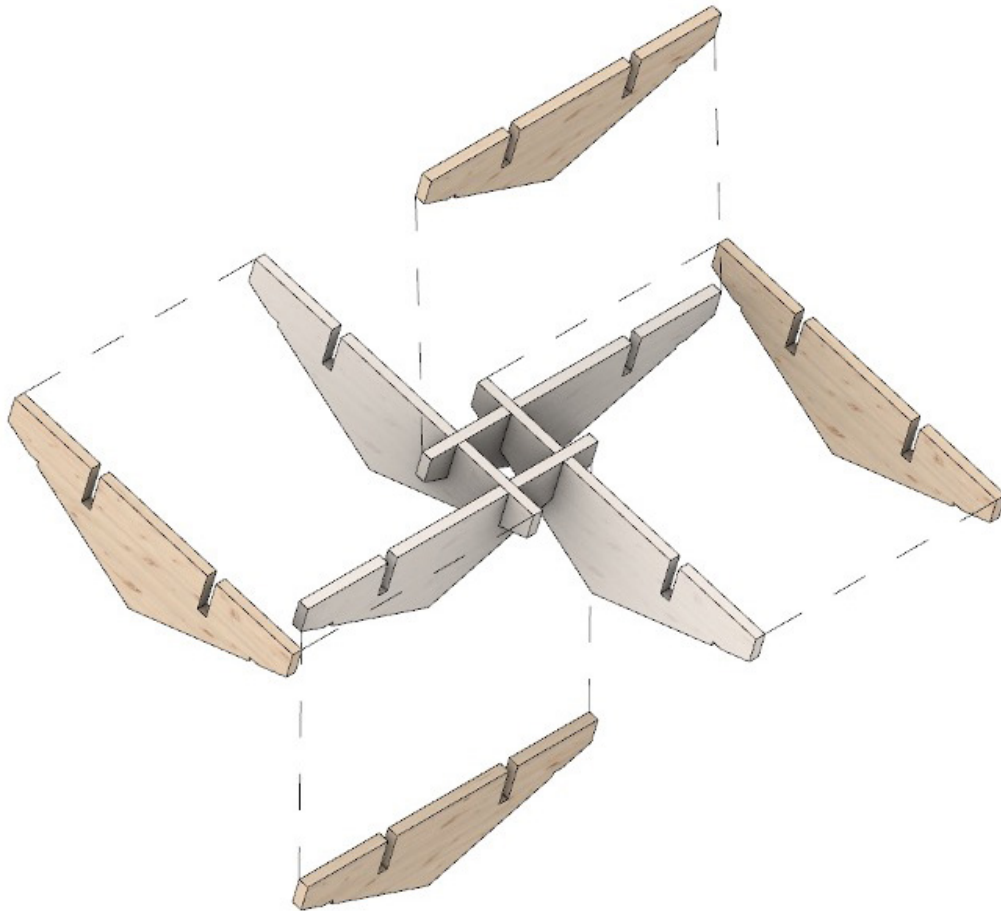

FIG. 9

Triangular node

Created by Team 4 Student Group

Carefully considering the timeframe and construction constraints for the project, the class chose a single arch as the design for the installation. To achieve the arch, options included a continuous curve defined by the angles of the triangular

pieces or a segmented arch with angle changes happening only at five or six distinct places. Because of the ability to construct a segmented arch in modular sections, the class decided to move forward with this option.

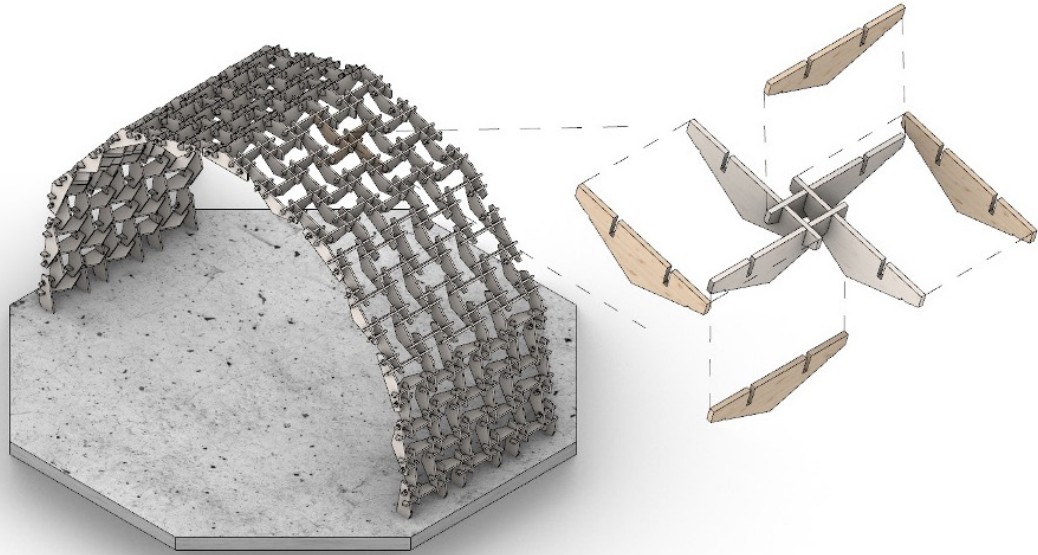

FIG. 10

Initial arch design

Created by Architectural Design Student Group

Then the class regrouped around different tasks. In parallel to developing the overall form, work was simultaneously being done on other aspects of the structure, with constant communication. Prototypes were developed at increasing scales to test the constructability and structural

integrity of the system. To protect users from the sun and rain, fabric was considered to wrap the structure. The team investigating the fabric proposed multiple ideas for the way it could be incorporated, such as with panels or strips.

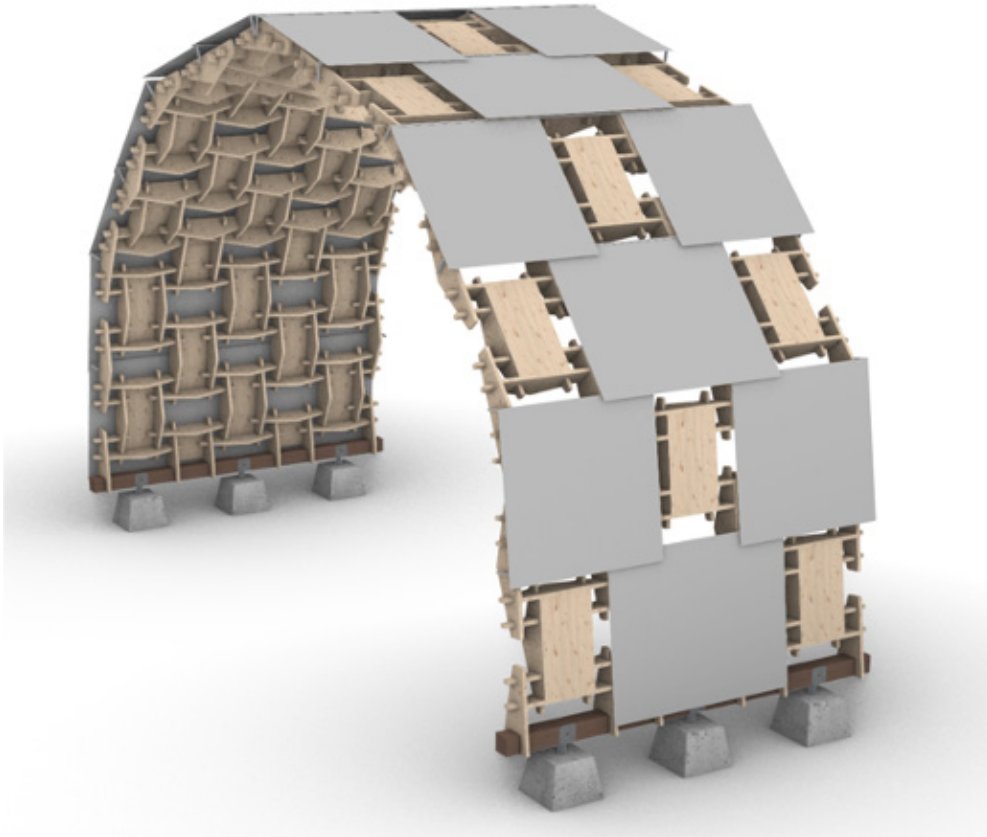

FIG. 11

Fabric and stiffening plates

Created by Additional Components Student Group

Structural Analysis

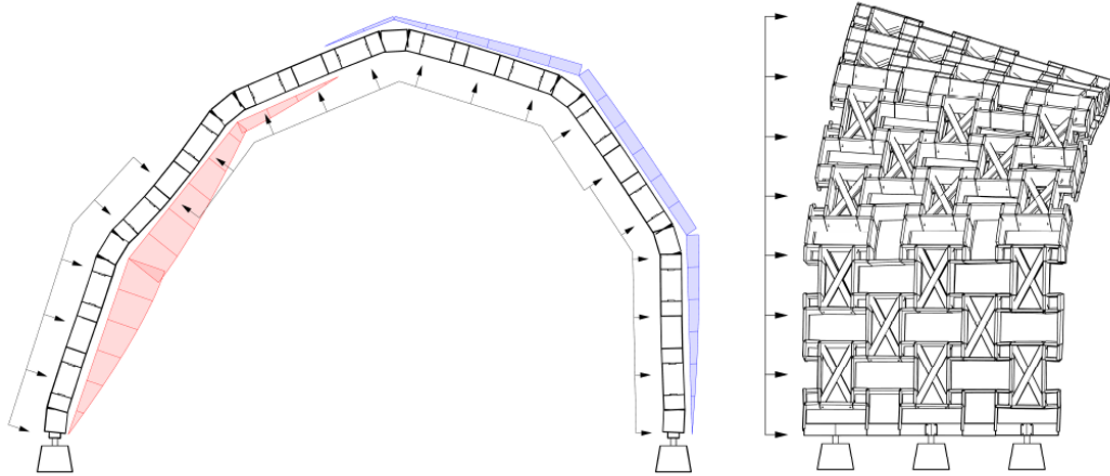

FIG. 12

Structural Analysis

Created by Structural Design Student Group

Structural analysis was done throughout the design process and at a variety of scales to inform and support design decisions. Analysis was also done to determine the minimum dimensions necessary for each piece to ensure adequate resistance to bending moment. These calculations showed that the ideal

member height should be 7" and the ideal tenon height should be 3.5".

A thorough structural analysis examining relevant regulations revealed that wind uplift would be an issue. To adjust for this, the class decided to move from a notched connection to a more stable mortise and tenon connection.

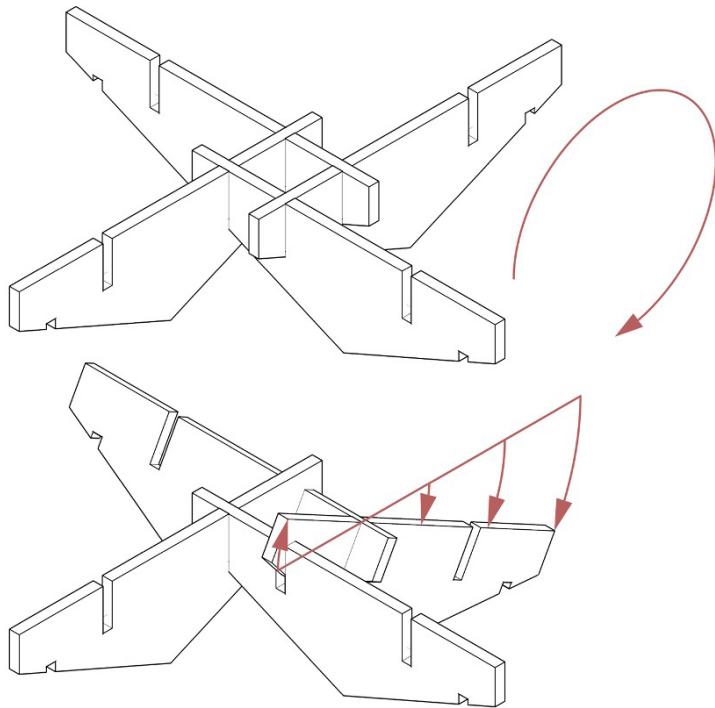
**FIG. 13**

Original Notched Connection

Created by Structural Design Student Group

To reduce uplift forces, the fabric rain protection panels could be secured only on one or two edges to allow wind to pass around it. Adding plywood stiffening plates on the outer face of the arch would create a more rigid structure. Students determined how much of the open space should be filled with panels and how these panels would connect to the frame.

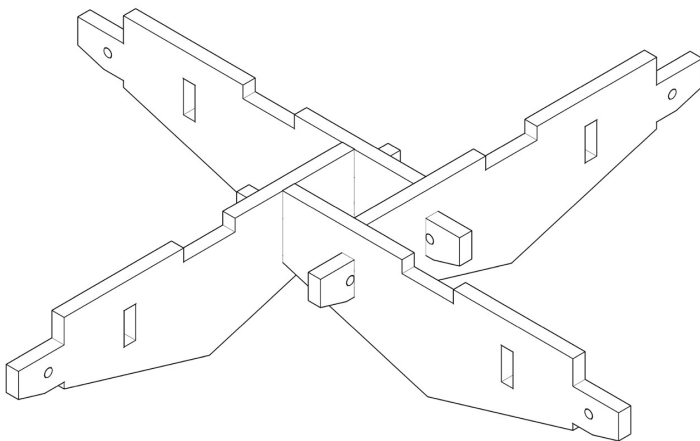
**FIG. 14**

Revised Mortise and Tenon Connection

Created by Structural Design Student Group

Design Refinement

An additional vital part of the design was the connection of the structure to the ground. Various iterations were considered with criteria such as ease of assembly, no ground disturbance, and structural stability. The final design features two rows of concrete blocks with brackets to hold two pressure-treated 4x4 members onto which the reciprocal frame structure is attached. Calculations were done to ensure the proper weight of concrete was used to keep the structure held in place.

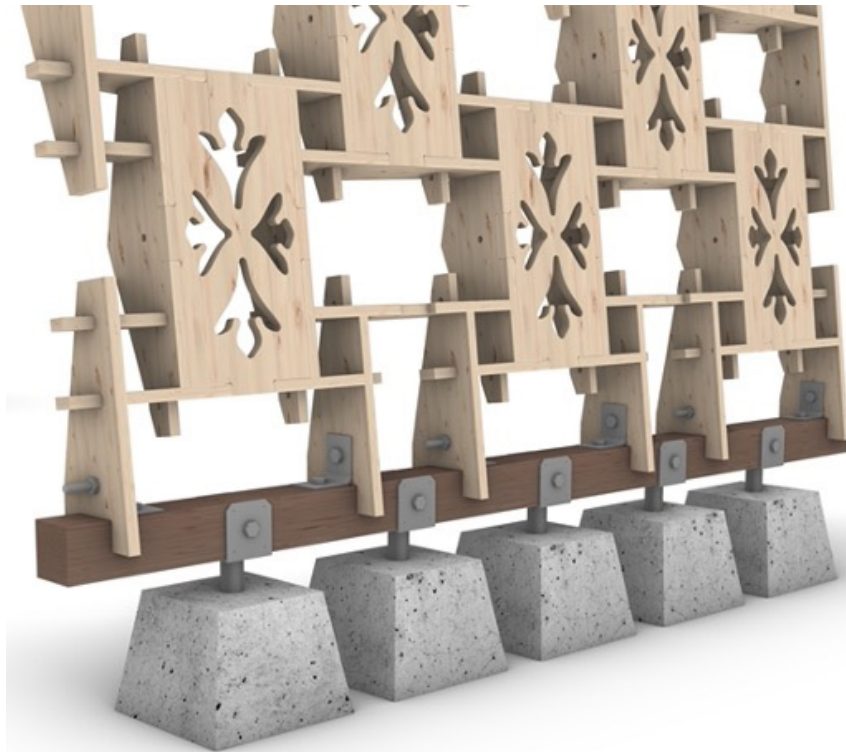

FIG. 15

Ground Connection

Created by Joints and Connections Student Group

Further design work also took place with respect to the stiffening plates. To address wind load concerns, holes needed to be cut into the stiffening plates. To ensure that the plates still worked to resist lateral

loads, no wood was cut out along the diagonals of the plate. The result was a leaf shaped cut out near each edge of the plate, leaving a framed X-shaped piece of wood to brace the structure.



FIG. 16

Stiffening plate design

*Created by Additional
Components Student Group*

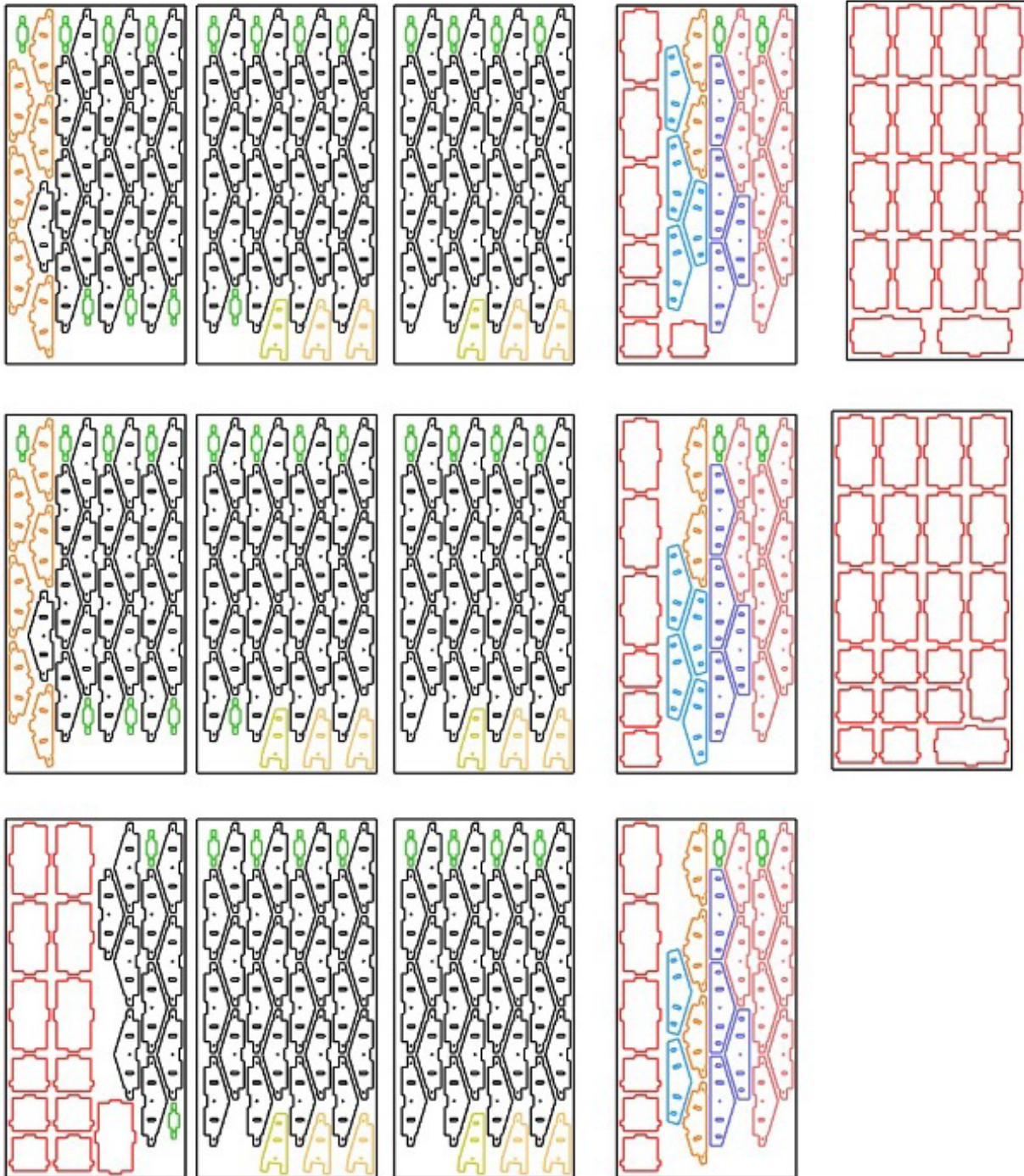

FIG. 17

Panel layout

Created by Joints and Connections Student Group

As design decisions were being finalized, a kit of parts was compiled to account for all that was needed to build the structure. Including the base pieces and stiffening plates, a total of 11 unique pieces were needed to complete the reciprocal frame structure. These pieces were digitally laid out on a series of panels to be cut out of 23/32" x 48" x 96" plywood sheets using a CNC machine. Because the actual thickness of the plywood sheets did not exactly match the nominal thickness,

tolerance between pieces were considered and adjusted for. Fourteen plywood sheets were needed to cut all the pieces required for assembly. Though initially planned for CNC machining to happen equally between UO and OSU, issues with the machine at UO meant panels were also sent to CNC WoodCutters for fabrication. All pieces were then delivered to the Emmerson Lab at OSU for assembly along with purchased items for the base.



FIG. 18

Pieces ready for assembly

Image by Charlotte Kamman

Research was done on the proper wood sealants and fabric and polycarbonate structures needed for weather protection, which were omitted for the initial interior assembly.

Assembly

Assembly ideas developed through hands-on prototyping. Initially, 3mm plywood was lasercut to create 1:6 scale models for testing joint and assembly method options. After iterative trials, a complete model was generated, along with a plan to be followed during full-scale assembly. Due to the instability of partially assembled modules, the plan was to create flat module-size jigs to align pieces and guide the module-to-module connection with the aid of a forklift or

crane. When the class came together to assemble the structure, the jigs were not needed since modules could be lifted and connected without difficulty. On site, shims were improvised to tighten the slightly loose mortise and tenon joints.

Therefore, the build process involved assembling a module on the ground with shims added concurrently, lifting the module onto place within the structure, then repeatedly adding modules to build the arch from the ground up.

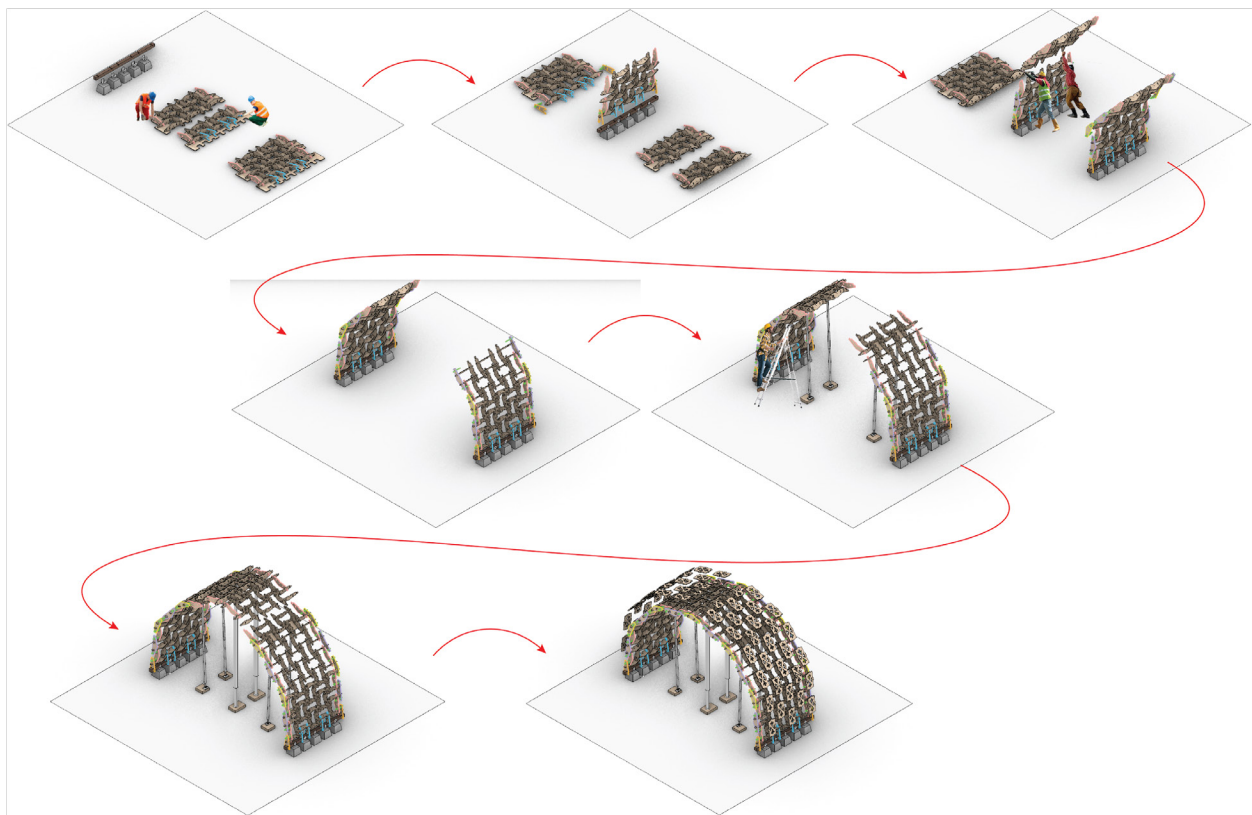

FIG. 19

Assembly process

Created by Fabrication Student Group

Extendable bracing was used to support the two sides while the top “keystone” module was being assembled on the ground. Because of the final height of the keystone, it was lifted by a gantry crane and suspended in place while students on ladders connected the edges to the adjacent modules. When this final

keystone module was secured in place, the crane support was released, and the structure sagged under its own weight but held in place, as predicted by the scale model. The arch’s construction and deconstruction plan can be found in Appendix C.



FIG. 20-A

Assembly

Images by Nancy Cheng

FIG. 20-B



FIG. 20-C





FIG. 20-D

Conclusion

From the design and construction process, the class has a range of takeaways and ideas for future revisions. To improve the structure's visual profile, adding tension cables perhaps with struts to the arch's spring point could reduce the arch's sag. Because this sag is caused by accumulating many tiny joint slippages, improving the tightness of the joints' fit would make the overall form more predictable. This might be done by adjusting the mortise openings to the exact thickness of each plywood sheet, which would remove the need for shims and greatly reduce assembly time of the structure. Alternatively, a joint that accommodates for variable thickness

panels would allow the design to utilize less uniform materials such as reclaimed wood.

Regarding the concern of people climbing the arch, there are two suggestions from the class. First, adding polycarbonate sheets researched for shading purposes could help make the arch less climbable on its exterior. Second, the arch could be designed to withstand the live load of climbers. This could mean thickening each piece or using a stronger material. Addressing vandalism concerns can be difficult as well, but ensuring a highly tight fit of pieces would make it harder for someone to easily steal pieces from the arch.

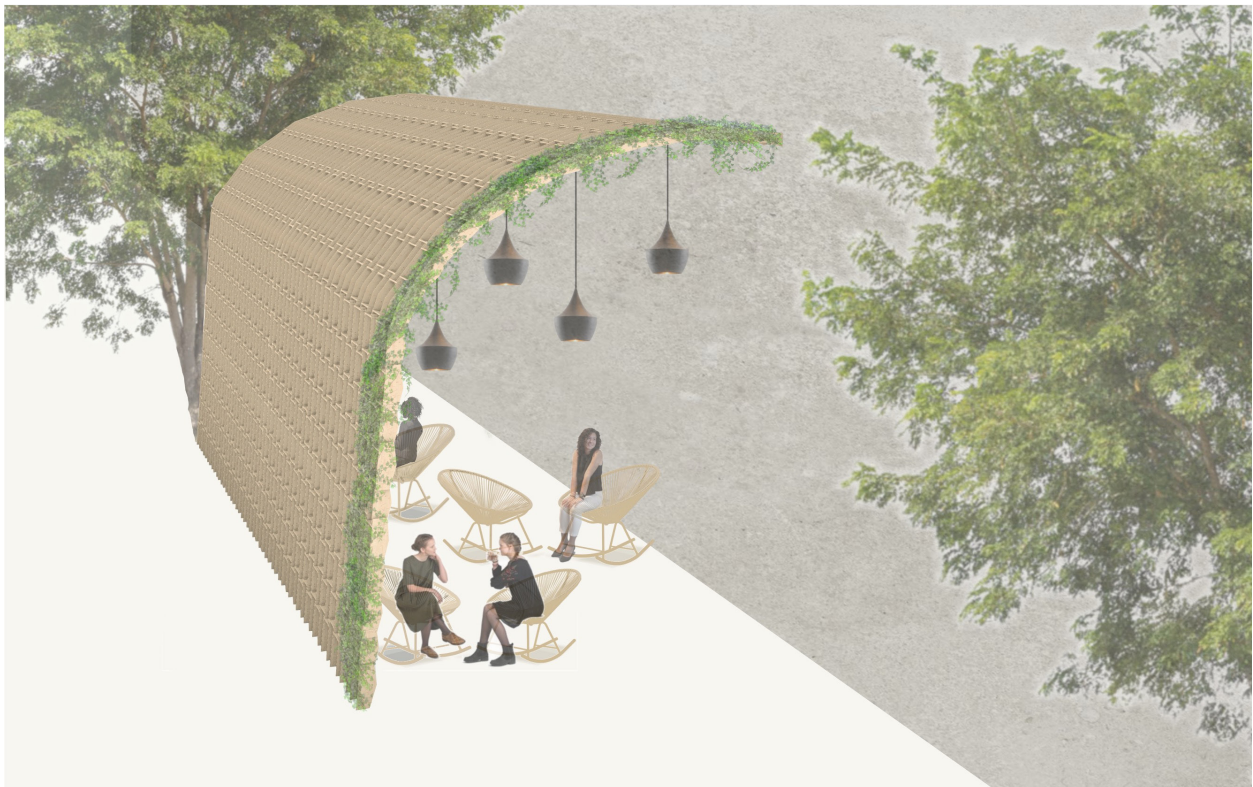

FIG. 21-A

Future applications

Created by Architectural Design Student Group

**FIG. 21-B**

This modular system is highly adaptable. The existing set can create framing of varied width and depth. Corner triangles can be combined to generate vaults of different curvatures. The system can be altered to create a variety of forms that

can serve many purposes. For example, adding corner triangles of different proportions or y-shaped pieces would further increase its versatility. Overall, future applications of this system are unlimited.



FIG. 22

Final assembly and team photo

Image by Tanner Koehn

Appendix A: Amended Final Presentation PDF



Contents

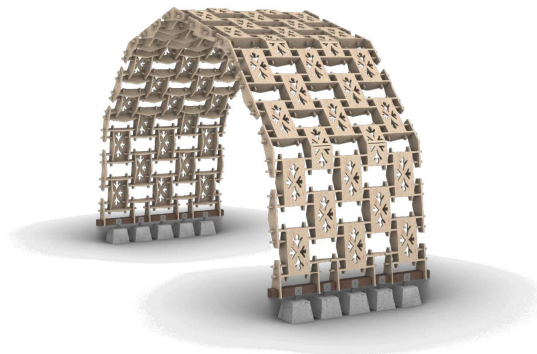

0	PROJECT INTRO	1	INITIAL DESIGN	2	STRUCTURAL TESTING	3	DESIGN REFINEMENT	4	FABRICATION	5	ASSEMBLY	6	FUTURE APPLICATIONS
	0.1. Brief		1.1. System		2.1. Overall		3.1. Drawings		4.1. Kit of Parts		5.1. Strategy		6.1. Structures
	0.2. Constraints		1.2. Form		2.2. Additional		3.2. Perspectives		4.2. CNC Process		5.2. Construction		6.2. Spanning
	0.3. RF System		1.3. Fabric		2.3. Connections		3.3. Scale Model		4.3. Refinements		5.3. Visuals		6.3. Furniture
	0.4. Goals		1.4. Stiffening Plate		2.4. Connection						5.4. Deconstruction		6.4. Credits
	0.5. Site		1.5. Prototypes										
	0.6. Explorations												



0.1 Brief

PROJECT INTRO

Objective: Explore building methods based on a kit-of-parts concept with a specific focus on the reciprocal frame construction system, known for its ability to cover large spans using short elements.

Client: City of Salem's Parks and Recreation Department

Site: Highland Park, 2025 Broadway St. NE, Salem, OR.

SPECIFICATIONS

KIT-OF-PART CONSTRAINTS:

- The design must incorporate reciprocal frame (RF) systems
- Materials will consist of .75" plywood.
- All components may be cut with a CNC router bit perpendicular to the surface of the panels.
- The design should minimize component variety.
- Roof-like elements should be used to reinforce and protect from rain and sun.
- All components may be interconnected using wood-to-wood joints.
- All joints should facilitate disassembly and component reuse, demonstrating principles of circular economy.

ADDITIONAL CONSTRAINTS FOR THE SELECTED SITE & PROGRAM:

- Material will be 20 sheets of .75" x 48" x 96" plywood
- Shelter footprint must be less than 120 square feet and maximum height 14'.
- All components must be fabricated considering the fabrication constraints of the CNC in the TDI's Emerson Lab.
- All components must be transportable in a cargo van with interior dimensions of 11' long, 4'6" wide, and 6'5" high.
- The construction needs to discourage climbing or ensure it could be safely climbed.



0.3 Reciprocal Frame Systems

PROJECT INTRO

- System of smaller members that work together structurally to create a larger span than the members length
- Small Elements for Long Spans
- Each Member is Supported Along the Length of Another Member

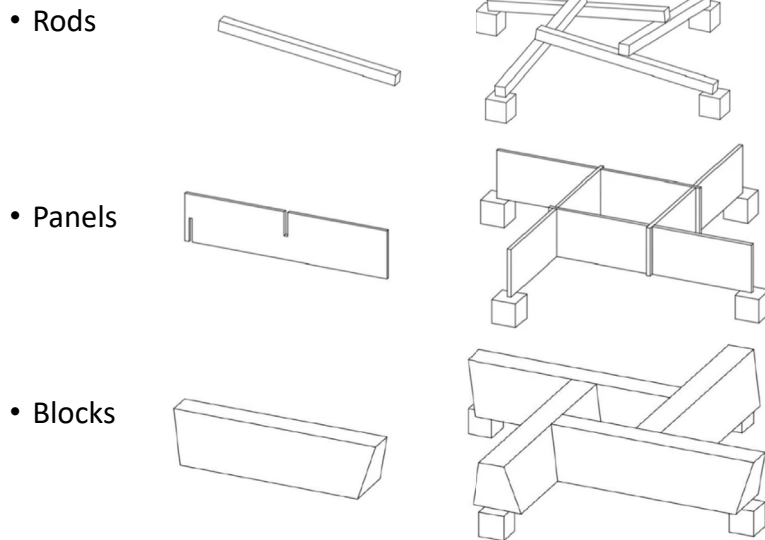

0.3 Reciprocal Frame Systems

PROJECT INSPIRATION



Experimental RF Structure
Royal Danish Academy,



5

0.3 Reciprocal Frame Systems

PROJECT INSPIRATION



Kyushu Geibunkan (Annex 2)
Kengo Kuma Architects



6

0.2 Constraints

PROJECT INTRO

- Material will be 20 sheets of .75" x 48" x 96" plywood
- Shelter footprint must be less than 120 square feet and maximum height 14'.
- All CNC cutting will be perpendicular to panel surface to simplify fabrication.
- All wood-to-wood connections

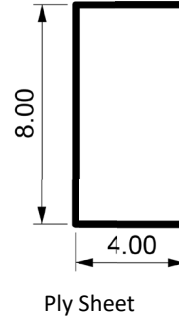
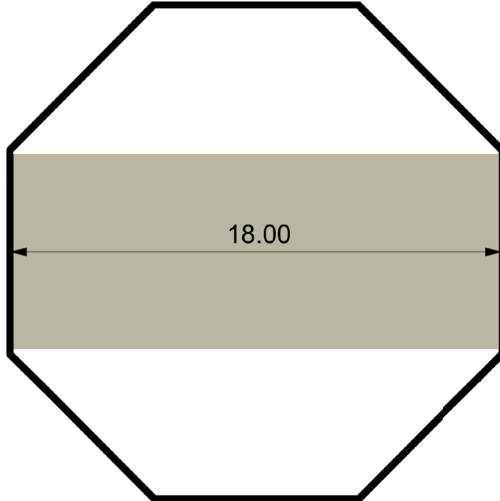

Site Constraint (120 s.f.)



0.4 Goals

PROJECT INTRO

PRAGMATIC REQUIREMENTS

1. Picnic Shelter
2. Performance Area
3. Discourages Climbing
4. Future Applicability

DESIGN METHODOLOGY

1. Reusable Kit of Parts
2. Bottom-up Approach
3. Design for Deconstruction and Reuse

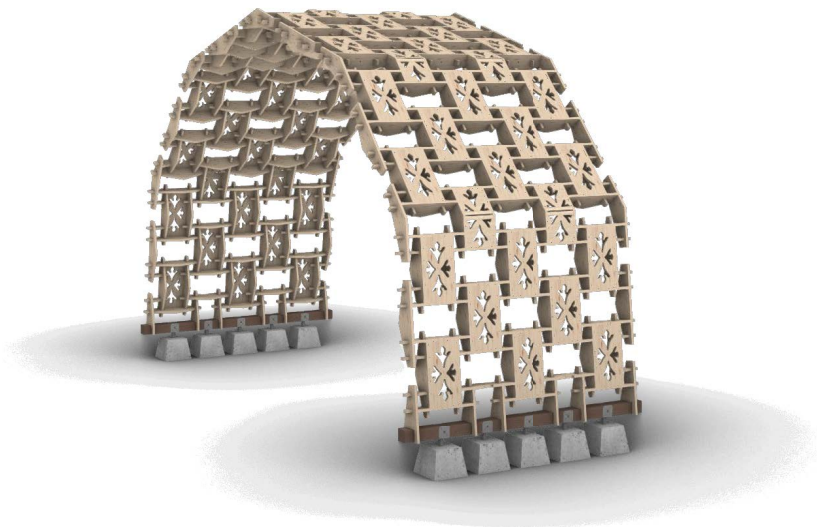

0.5 Site

PROJECT INTRO



0.6 Explorations

PROJECT INTRO

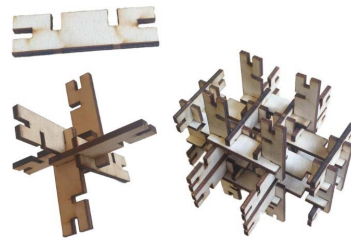
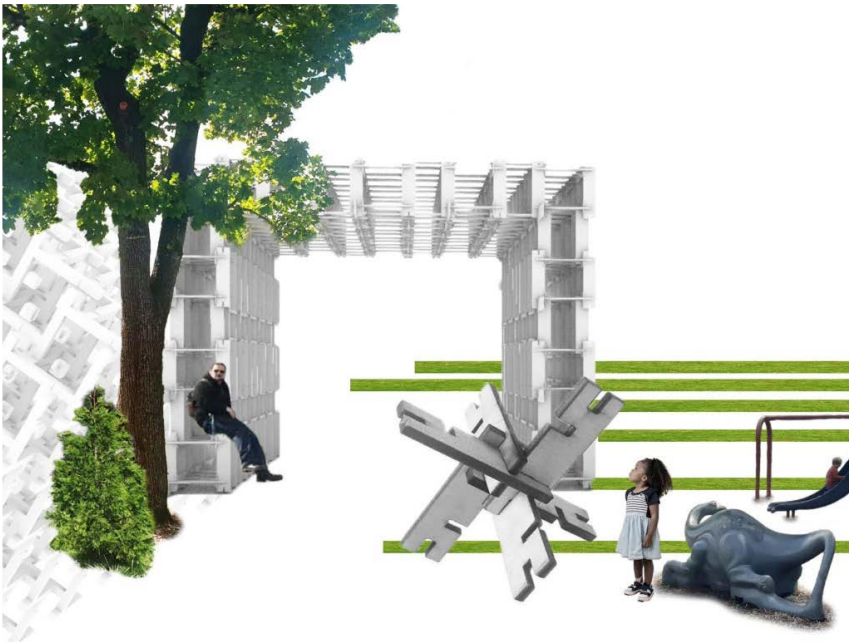

Team 1
Nic Ernst, Harvey Smith, Marie Lee, Lara Diehm



0.6 Explorations

PROJECT INTRO

Plan

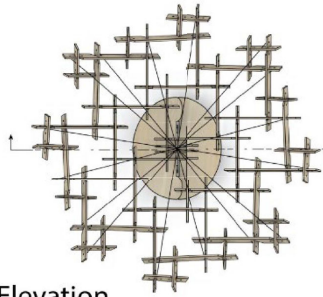

Elevation



Team 2
Anthony Newton, Igor Lopez, Jin-wei Chu



0.6 Explorations

PROJECT INTRO

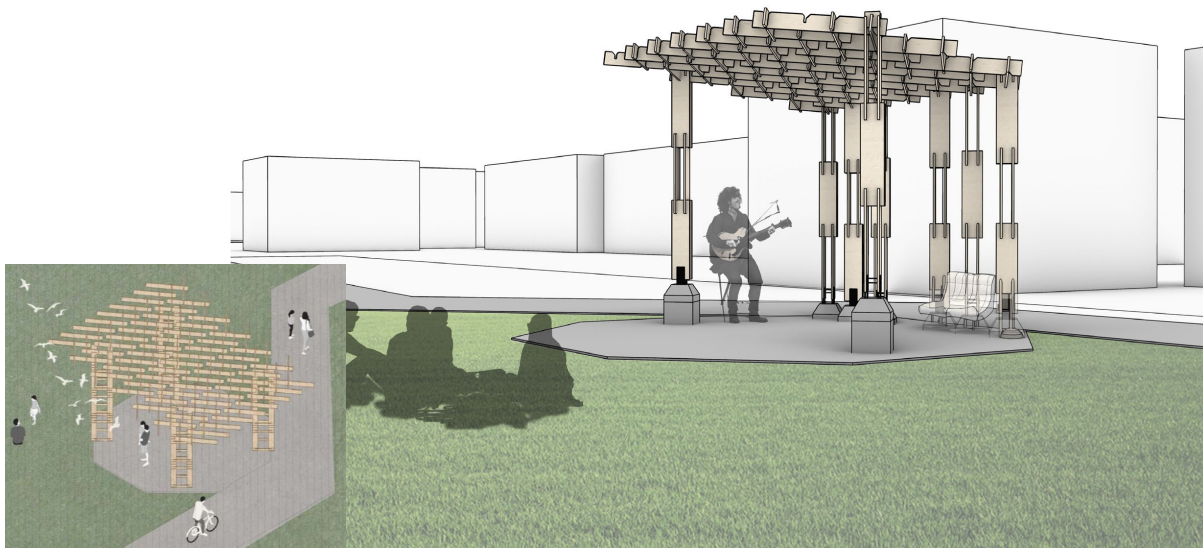

Team 3
Jackson Megy, Bryan Sherlock, Braden Lawrie, Yasmeen Sundareswaran



0.6 Explorations

PROJECT INTRO

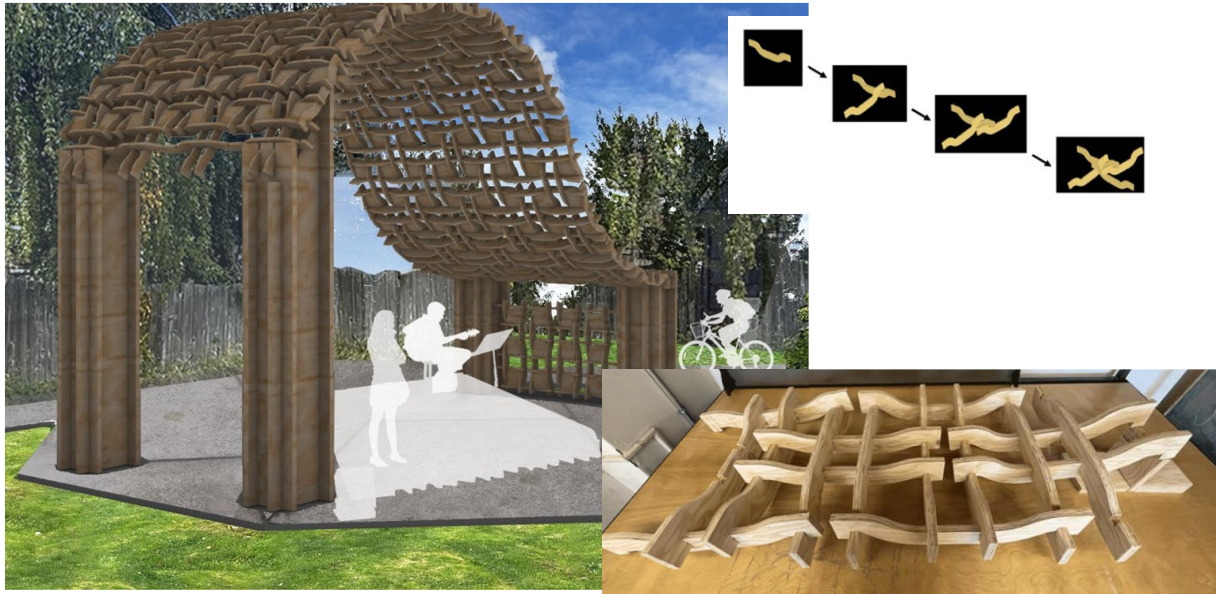

Team 5
Michelle Jayawickrama, Rory Doerksen, Sage Fetkenhour, Seunghyeon Park



13

0.6 Explorations

PROJECT INTRO



Team 4
Elisia Alampi, Charlotte Kamman, Andrew Kesterson, Nick Thielsen



14

1.1 System

INITIAL DESIGN



Inspired by Kengo Kuma Architects' Kyushu Geibunkan (Annex 2)

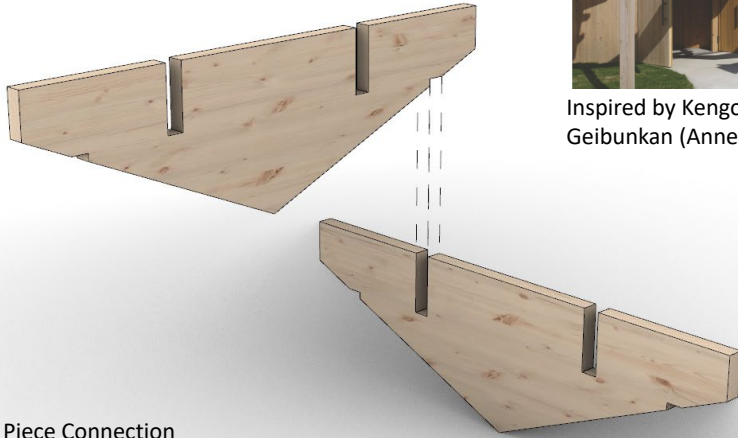

Piece Connection



1.1 System

INITIAL DESIGN

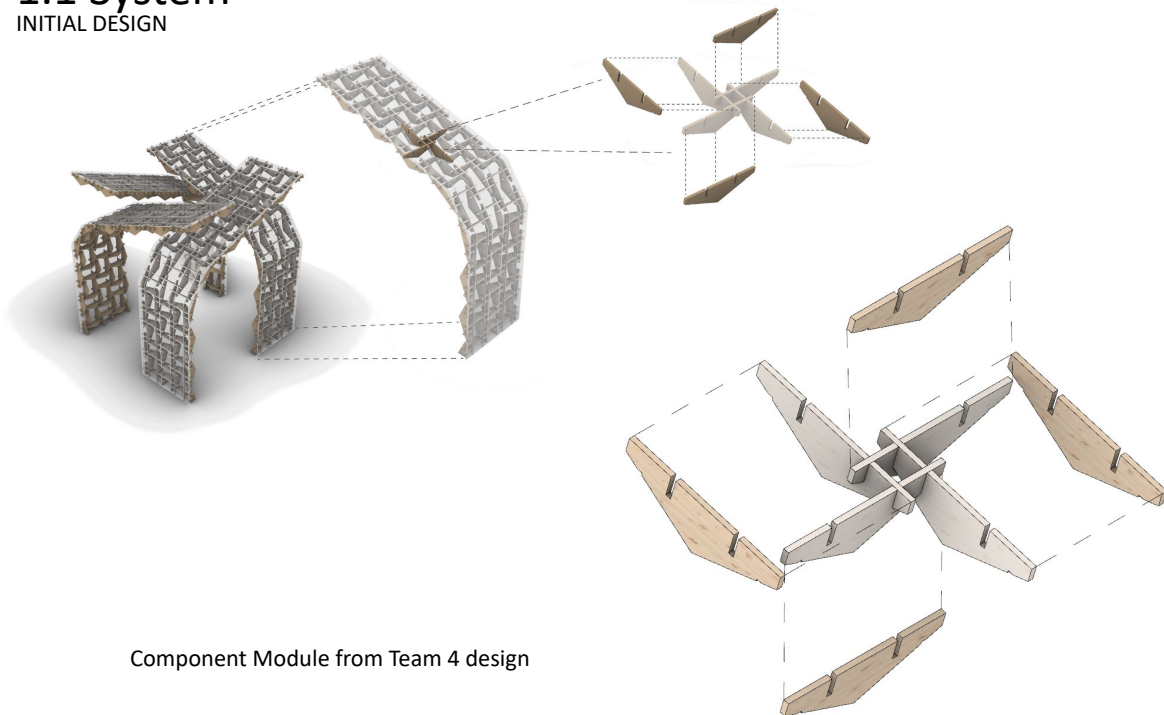

Component Module from Team 4 design



1.2 Form

INITIAL DESIGN

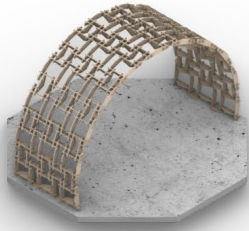

- Option 1: Continuous angled arch**
- Triangles define curvature
 - Advantages:
 - Structural stability since structure is in continuous compression
 - Disadvantages:
 - Relative complexity: requires multiple pieces of different lengths in order to achieved desired height/radius
 - Concerns about notch depth

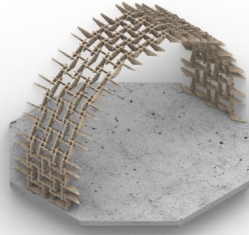

- Option 2: Segmented arch with flat roof**
- Advantage:
 - Easier to construct modularly
 - Disadvantage:
 - Less structurally stable than Option 1 (not in continuous compression)
- Flat roof – potential for water collection

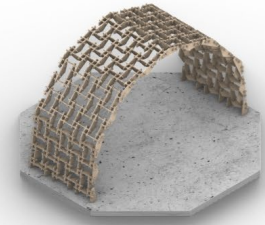

- Option 3: Segmented arch with middle sections connecting at the center**
- Advantages:
 - Eliminates flat roof
 - Possible to achieve desired height
 - Aesthetically pleasing form with continuity of shape
 - Structural stability
 - Disadvantages:



1.2 Form

INITIAL DESIGN

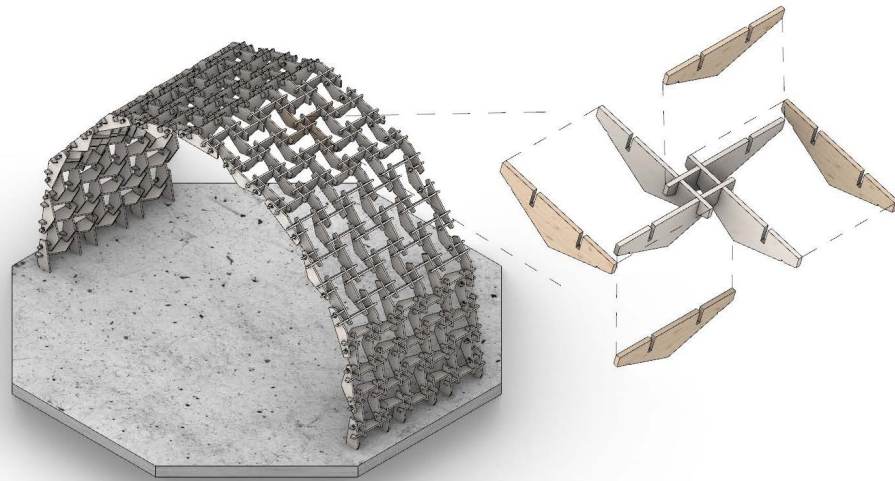

1.3 Fabric INITIAL DESIGN

First Looks at rain and sun protection

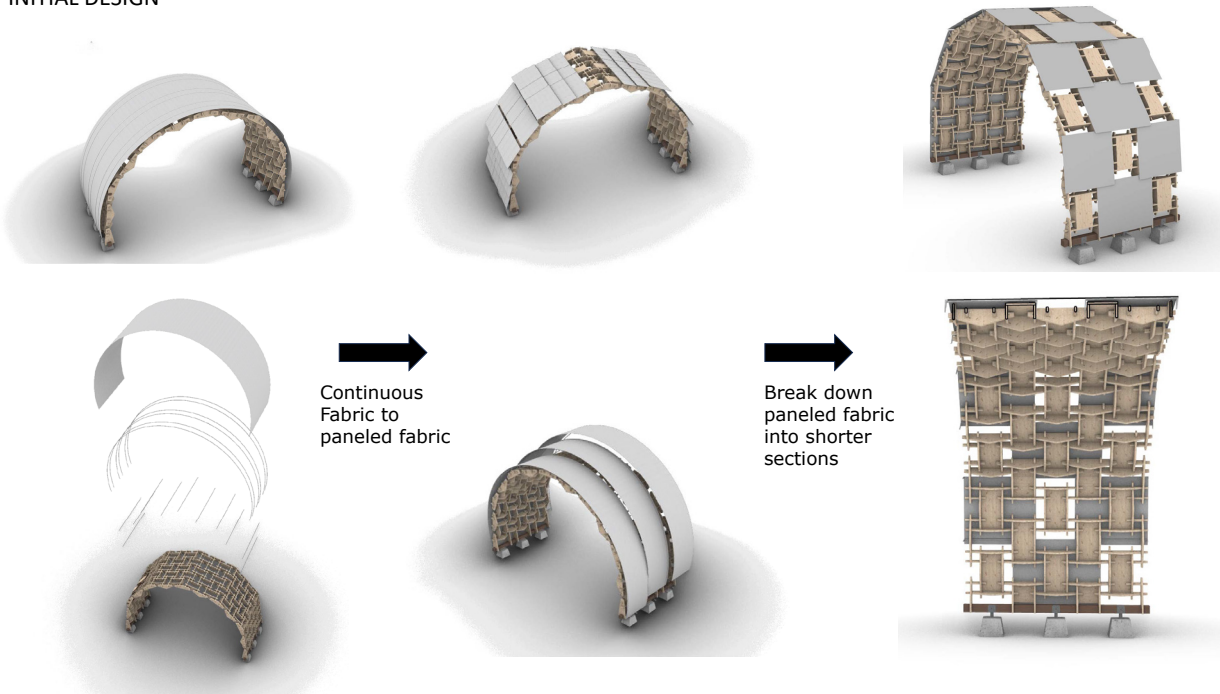

1.4 Stiffening Plate INITIAL DESIGN

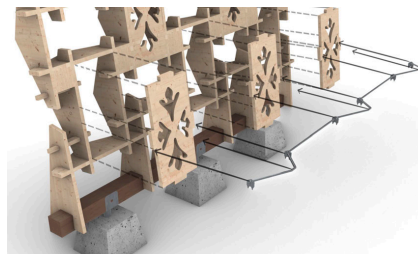
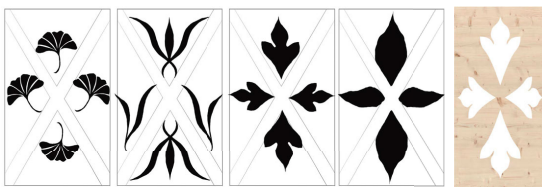
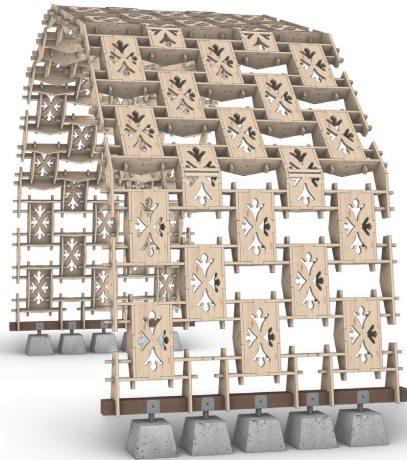
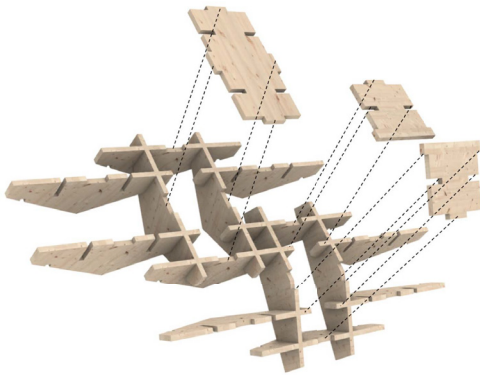

1.5 Prototypes

INITIAL DESIGN

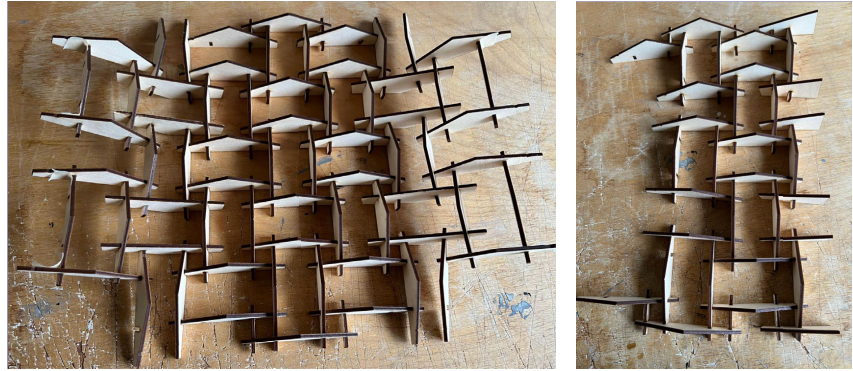

1.5 Prototypes

INITIAL DESIGN



2.1 Overall System

STRUCTURAL TESTING

Structure under windload – Forces and Deformations

Loads [kip/ft]

Members | Moments My [kip-ft]

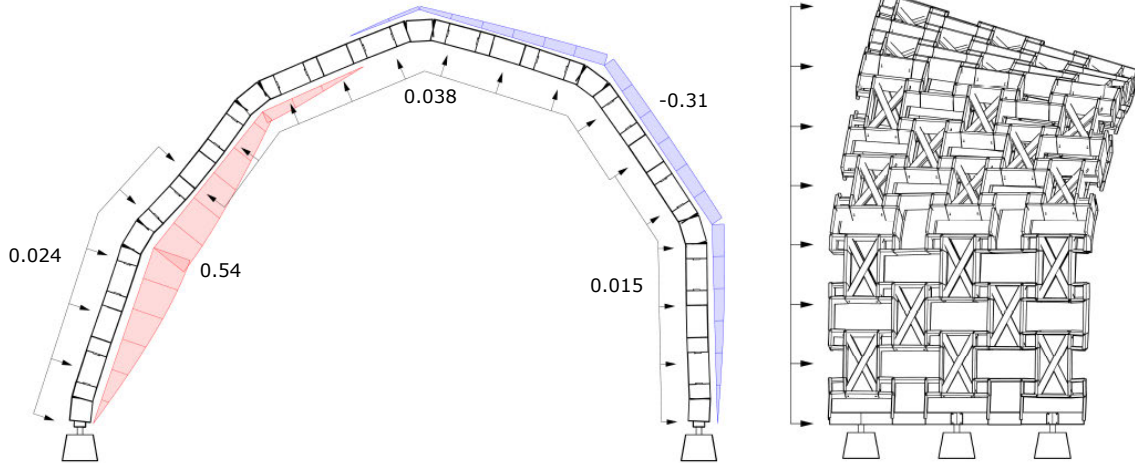

Members | max My: 0.54 | min My: -0.31



2.2 Additional Components

STRUCTURAL TESTING RESPONSE

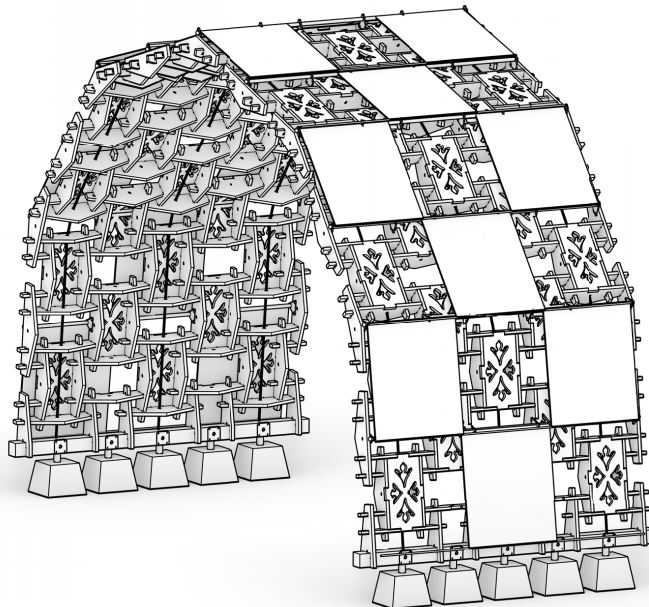

Fabric:

- Can be blown up by wind from below
- Perforation in the bottom to enable air circulation
- > Significant reduction of wind loads

Tension Cables:

- Cables spanning along the curve of the arch
- > Influence the distribution of forces

Footings:

- Concrete Blocks build a removable connection to ground
- > Prevent uplift and movement of the structure through weight and friction on ground



2.3 Connection Changes

STRUCTURAL TESTING

Change in the connections between elements:

Old Connections: Notches

Fall apart when moment is applied in the wrong direction.

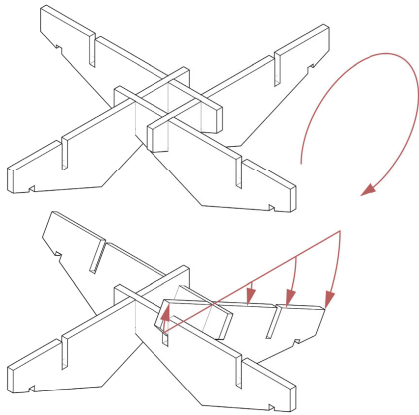

New Connections: Mortis and Tenon

Much more stable. Can take all the required forces.

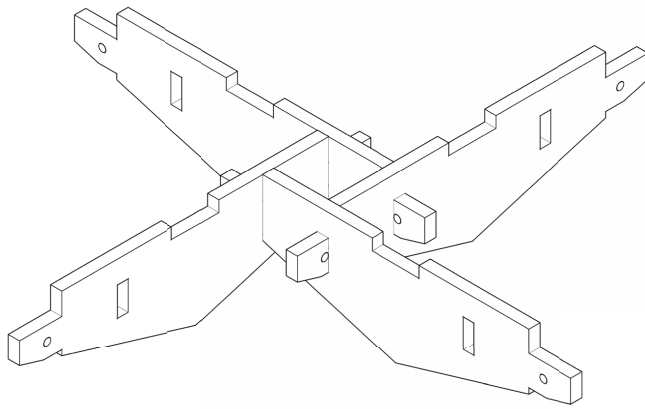

25

2.4 Connection Analysis

STRUCTURAL TESTING

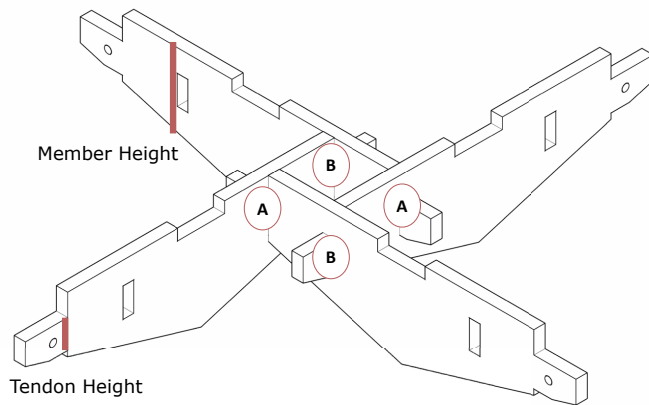

How is the bending moment passed between elements?

Variant 1: Force Couple

The moment is transmitted through opposite forces at connection A and B.

Variant 2: Moment Distribution

The moment is shared between connection A and B. Each takes half of the moment.

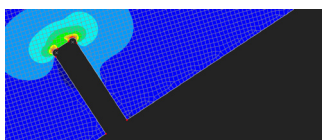

Cross section optimization:

Member | max M_y : 0.54 kip-ft
Design bending strength: 901 psi

Tendon Height: 3.5"
Member Height: 7"



26

3.1 Drawings

DESIGN REFINEMENT

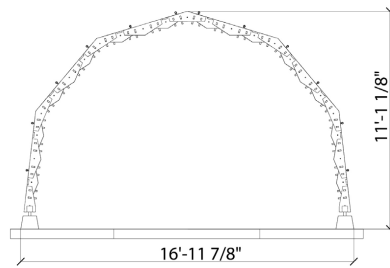
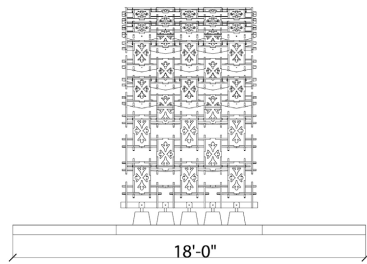
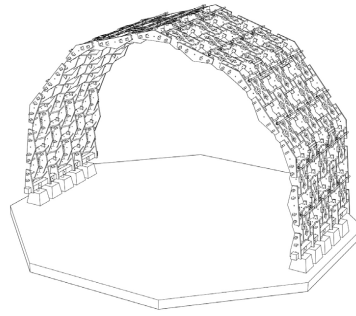
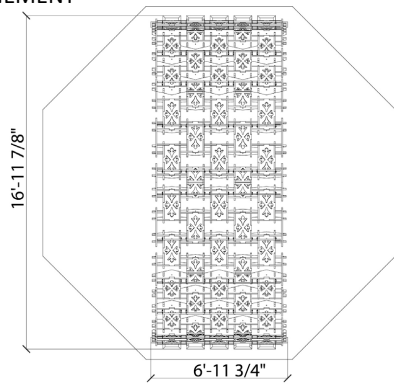

3.2 Perspectives

DESIGN REFINEMENT



3.3 Scale Model

DESIGN REFINEMENT



4.1 Kit of Parts

FABRICATION

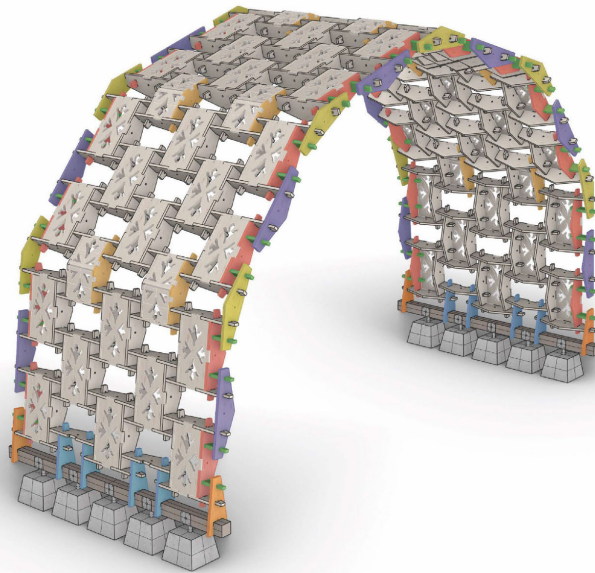

Piece 1		x192
Piece 2		x24
Piece 3		x12
Piece 4		x48
Piece 5		x96
Piece 6		x20
Piece 7		x10
Base Piece 1		x8
Base Piece 2		x4
Stiffening Plate 1		x24
Stiffening Plate 2		x48

4.1 Kit of Parts

FABRICATION

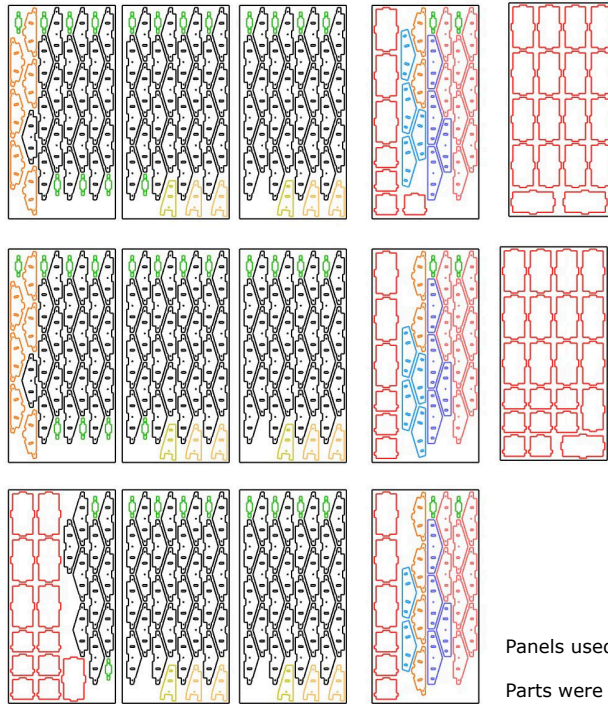

Panels used for CNC cutting
Parts were cut at UO, OSU, and CNC WoodCutters

4.1 Kit of Parts

FABRICATION

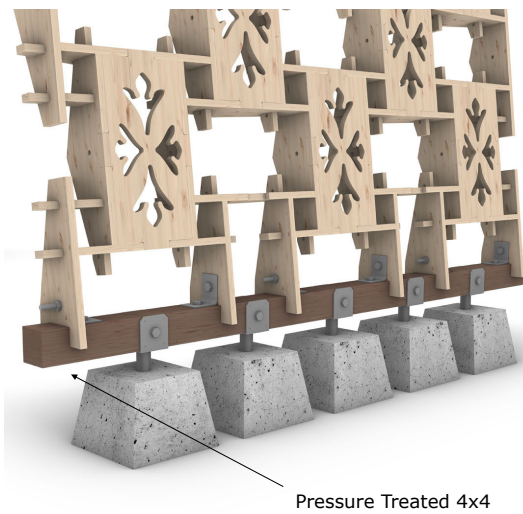

Pressure Treated 4x4



Concrete Blocks with Brackets

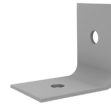

L Brackets



5" by 1/2" Bolts



3" by 1/2" Bolts



1/2" Screws



1/2" Nuts



1/2" Washers

4.1 Kit of Parts

FABRICATION

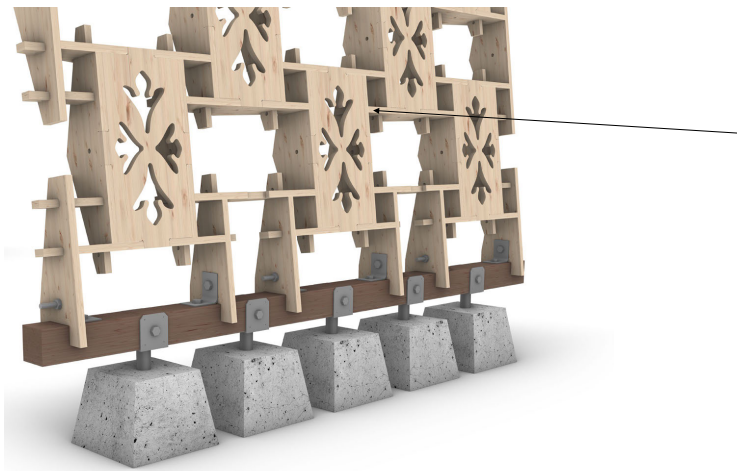

Wood Sealant

- Provide a better finishing.
 - Covering and protection.
- Stabilize and Protect wood species that are used for outdoor exposure.



4.1 Kit of Parts

FABRICATION

Wood Sealant proposed by Gerry Presley (OSU)

CALL US TOLL FREE: (888) 888-6095 OR 503-232-1705 (In Portland, OR)

RESTORE & PROTECT
The natural wood and masonry in your home with our safe, durable, and easy to maintain products.

Natural Wood Stains & Finishes

FIND YOUR PROJECT ▾ OUR PRODUCTS ▾ COLORS TECH INFO ▾ PHOTOS ABOUT, CONTACT & HOW TO BUY ▾

Deck & Fence Formula



- 70 colors to choose from. Also available in clear (sealer only, with no sunscreen)
- More durable than typical brand name stains
- Environmentally safe, only 34 grams per liter VOC's, so little odor
- SCAQMD approved for Southern California
- Renewable plant oil based, no petroleum oils
- Nonflammable, water clean up
- Dries and bonds, no oily residue to attract dirt
- Wood stays cleaner than most sealers
- Easy to apply and retreat without stripping
- Also available in clear (sealer only, with no sunscreen)

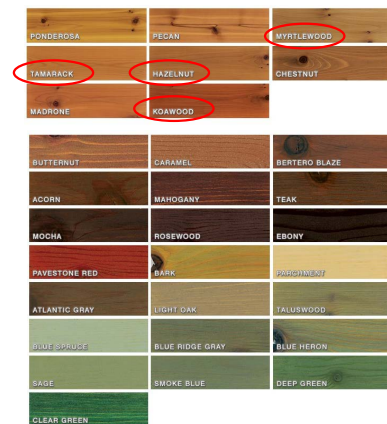

<https://timberprocoatingsusa.com/products/deck-fence-formula/>



4.1 Kit of Parts

FABRICATION

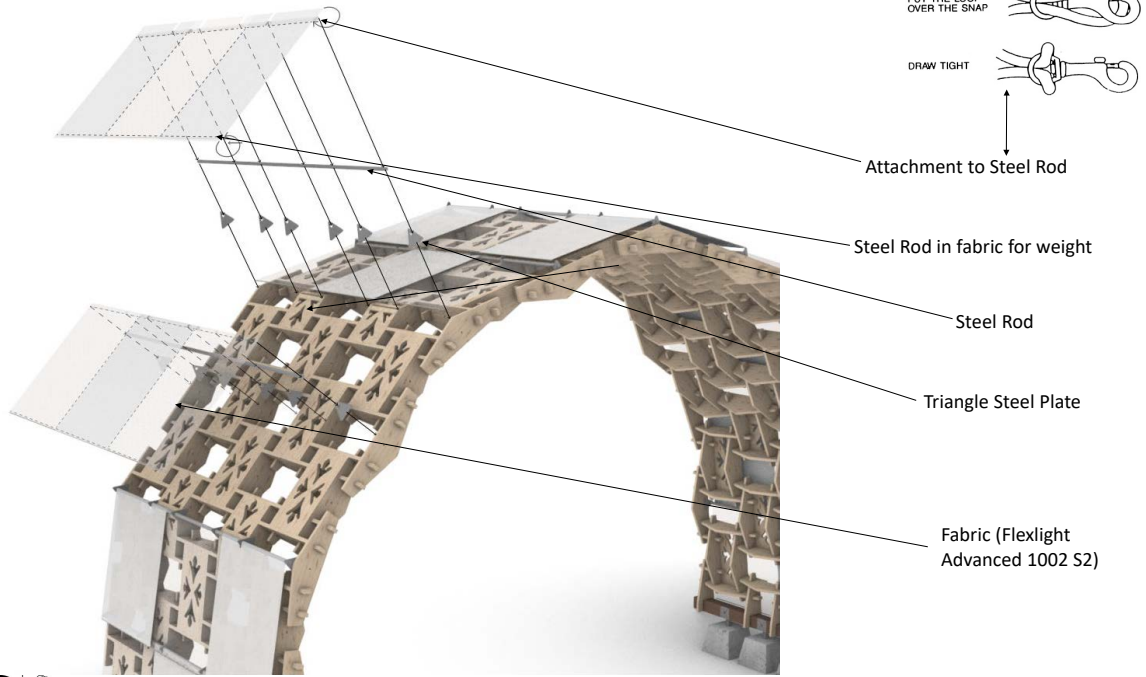

4.2 CNC Process

FABRICATION



4.3 Refinements

FABRICATION

- The tolerance for the best fit was tested using the UO CNC.
- After cutting on the OSU Emmerson Lab CNC, connections were too loose and needed shims.

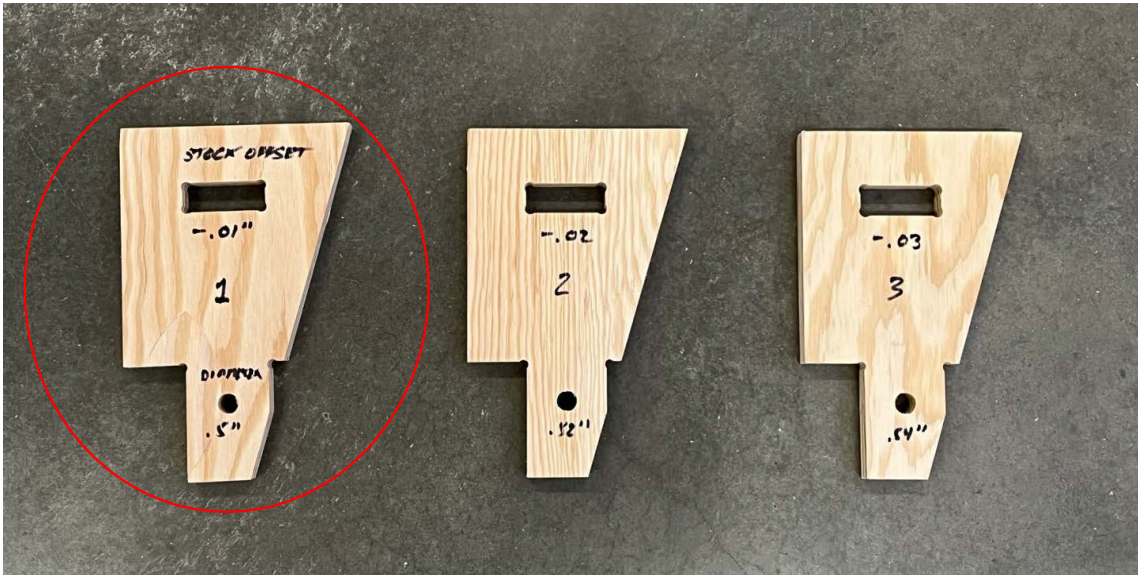

37

5.1 Strategy

ASSEMBLY

Lots of ideas regarding assembly:

- Jigs to secure panels
- Assembly on ground, raise full structure like barn
- Use of overhead crane or forklift due to weight

Process Final Draft:

1. Assemble panels 1/2, 5/6 on ground
2. Raise/shore
3. Assemble panels 3/4 on ground
4. Raise/fit

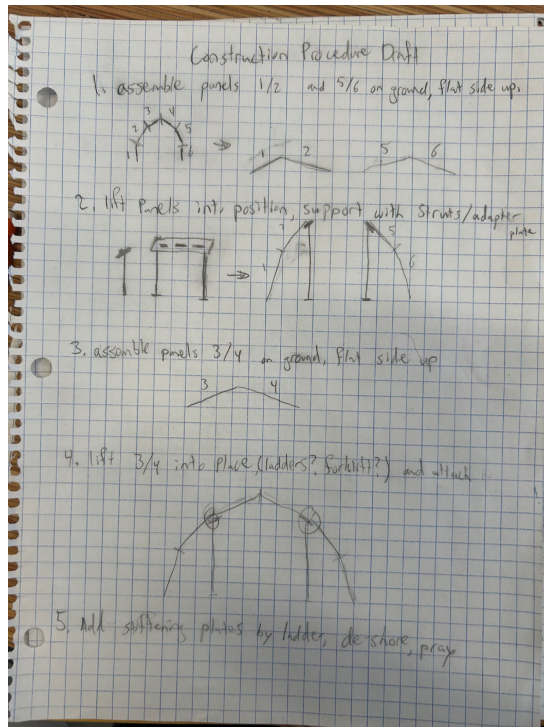

38

5.3 On-site Assembly

MODULAR CONSTRUCTION



5.4 Final Construction

OSU EMMERSON LAB

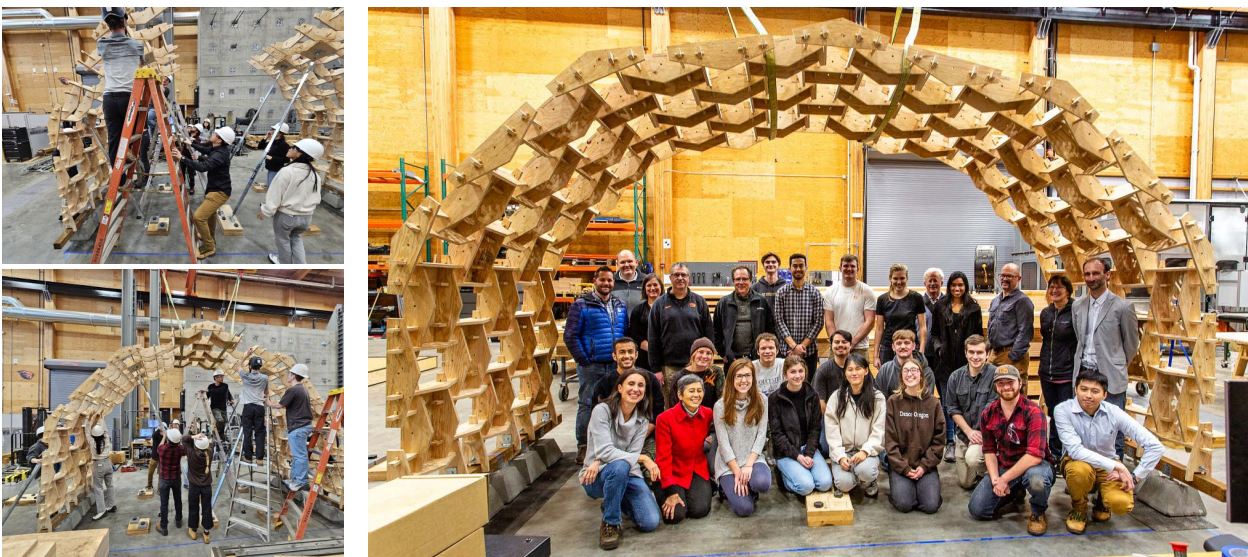

5.5 Deconstruction

DISASSEMBLY STRATEGY

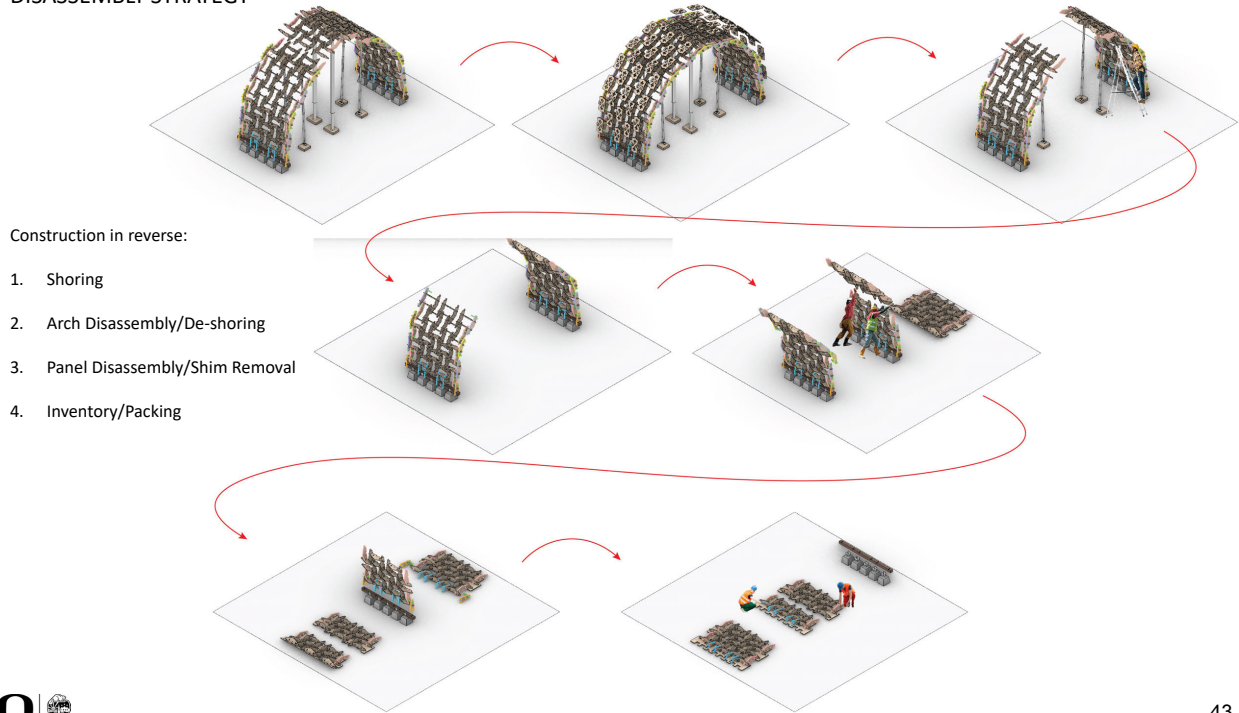

6.1 Structures

FUTURE APPLICATIONS



6.2 Spanning Elements

FUTURE APPLICATIONS



6.3 Furniture

FUTURE APPLICATIONS



6.4 Credits

STUDENT TEAM:

Architectural Design: Braden Lawrie, Yasmeen Sundareswaran, Seunghyeon Park, Michelle Jayawickrama

Structural Design: Nick Thielsen, Lara Diehm, Jackson Megy, Rory Doerksen

Joints and Connections: Charlotte Kamman (UO Project Manager), Elisia Alampi, Anthony Newton, Harvey Smith

Additional Components: Nic Ernst, Igor Tiago-Lopes (OSU Project Manager), Marie Lee

Fabrication: Jin-wei Chu, Sage Fetkenhour, Bryan Sherlock, Andrew Kesterson

INSTRUCTORS:

Prof. Mariapaola Riggio, Wood Science and Engineering, Oregon State University

Prof. Nancy Cheng, Architecture, University of Oregon

ACKNOWLEDGEMENTS

Tallwood Design Institute supported this inquiry into Building for the Circular Economy with reusable, reconfigurable components, allowing the assistance of OSU PhD student Alireza Yari. TDI staff Phil Mann, Mark Gerig and Byrne Miyamoto provided CNC routing and construction support.

UO College of Design Fabrication manager Tom Coates worked patiently with the students to guide successful CNC cutting of multiple prototypes in Eugene.

UO Sustainable City Year Program funded crucial expenditures, connected us to the City of Salem's Strategic Initiatives Manager Courtney Knox Busch and Parks Planning Director Robert Romanek, leading to participation of Engineers Aaron Kimsey and Ryan McGraw and Highland Park resident stakeholders. Marsha Gravesen expedited the purchases and provided gracious support for events related to the project.

Roseburg Forest Products contributed the plywood used in the project.

The UO Department of Architecture supported the studio with a research grant which allowed hiring of B.Arch. student Grayson Wright to assist the class.

The UO Women of Color Summer Writing Fellowship provided funds to hire research assistant Josh Weber for initial explorations, which were done with the help of Justin Tuttle, UO Portland Workshop Technician.

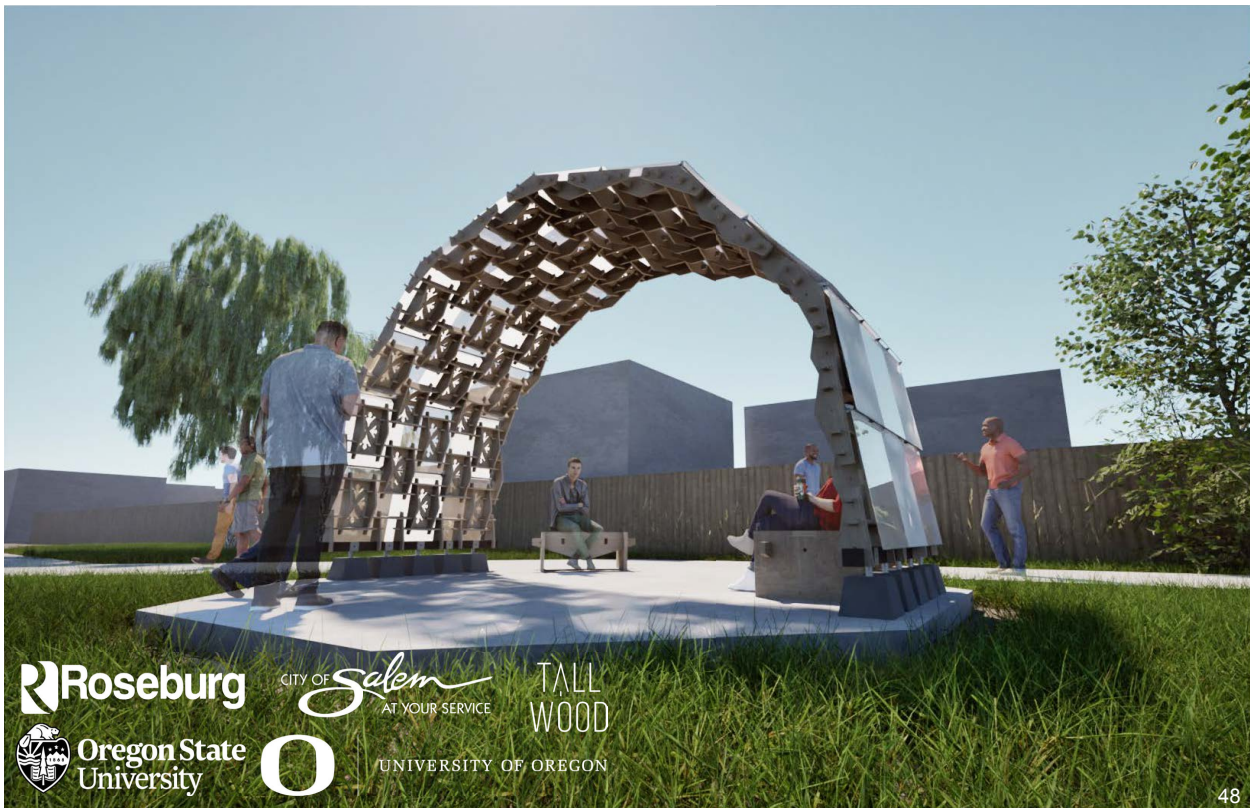

Appendix B: Structural Design Report

Lara Diehm
 Jackson Megy
 Nicholas Thielsen
 Rory Doerksen

Final Report and Reflections
 Team B - Structures

THE HIGHLAND ARCH – Structural System Introduction

The structural system of the Highland Arch is a reciprocal frame, loosely inspired by the Kyushu Geibun Kan Museum. As with all reciprocal frames, each individual member supports and is supported by, the members it is in contact with. In this case, the primary member is a 24" x 6 ½" triangular plywood panel cut from 23/32" Douglas Fir plywood. Four panels joined together form a "node", the fundamental pattern that is repeated throughout the structure. As many, or as few nodes as desired can be attached to create larger "sections". Similarly, multiple sections can be attached to form larger "modules". The Highland Arch combines 6 modules, each containing two, 12-node sections.



Member-to-member connections were custom-designed to facilitate a variety of loading conditions. A mortise and tenon style approach was used to allow the structure to accept forces from the top down (such as those associated with its self-weight, rain, snow, etc.), as well as from the bottom up (such as uplift caused by wind pressure). With the exception of the connection to the foundation, all members are attached via wood-to-wood connections. These connections are not perfectly rigid and allow some rotation of the adjoining members. This relieves internal stress from the members themselves, providing whole-structure resiliency.



Stiffening plates with aesthetic floral patterns cut into them provide further rigidity to the structure. The plates, made from the same material as the members, keep the spaces between four nodes square. This restricts the ability of the structure to twist, reducing torsion forces at the joints, as well as undesirable deformations of the whole structure.



The base design of the arch primarily functions to resist uplift forces caused by winds, as well as thrust forces from the weight of the structure as it "tries" to push the base away from the center.



Further Analyses (see following pages)

Marine Plywood

- Different reference design values than for Grade A-C were required
- Density of 37 pcf was required

Polycarbonate panels

- Increased dead load due to weight of polycarbonate was required
 - $(\text{area density of PC}) * (\text{arch width}) = \text{linear density of PC along arch}$
 - $(1.5 \text{ lb/sqft}) * (6 \text{ ft}) = 9 \text{ lb/ft}$
- Wind load configuration
 - Using a hinge at the attaching edge of the polycarbonate panels and a curved profile at the opposite edge will enable air to pass through the structure in all directions without applying a significant wind load.

Lessons Learned (Phenomena during construction)

Rotation at loose joints and settling at falsework removal

During the construction process, there were multiple phenomena that were recorded. Three of the most prevalent were the rotation at joints, settlement of the structure, and the supports not being perfect pins. after the shoring was removed. The rotation at joints was noticed during the assembly of the sectionals. Even with the tusks, the joints were still extremely loose. This was circumvented by shimming every single joint, however, this was not a consistent solution. It is believed that the cause of this was manufacturing errors. The CNC system is very useful, however, not the most accurate. This problem can be solved by using more precise drawings or CNC equipment. This would provide tighter and cleaner cuts. Another solution would be to hand-cut the pieces, but again, this would have some accuracy problems. The settlement of the structure was noticed immediately after the shoring was removed. The sag was most noticeable in the upper sectional, however, the middle sectionals also experienced sag to a lesser degree. This settlement was believed to have occurred due to the overall lack of stiffness in the structure. This can be circumvented in a couple of ways. The first is to add compression and tension elements to the structure. The tension elements would connect the peak and to the elbow between the lower and middle sections. This would help pull the whole structure together and reduce the sag. The compression elements would connect the elbows between the top two sections to the base and would, again, help raise the structure and reduce the sag in the middle section. The second is to fix the joint rotation issue. This would help the overall stiffness and reduce overall sag in the structure.

Supports weren't perfect pins - stopped deflection

The location where the bottom members meet the 4x4 footing timber provided another unexpected phenomena. At these conditions, the member is slotted to fit over the 4x4 and then bolted with Simpson-Strongtie HR33 angle brackets. As the bracket uses a single bolt to provide uplift resistance, the structural model assumed this condition to behave as a perfect pin. In reality, however, cumulative deformations throughout the structure caused the member to rotate so far around the pin that the slot in the plywood jammed against the 4x4. This, in turn, caused the condition to behave as a moment connection, implying internal forces which were not considered in the original design, nor in the structural model. Ultimately, this appears to have had a net-positive effect on the stability of the structure, however further analysis should be performed to confirm the suitability of the member at this condition.



Further Considerations

After completing construction of the Highland Arch and letting it stand for a couple of days, measurements were taken to demonstrate the deformation that occurred with respect to each “corner” between linear arch segments (see figure below). These measurements were then cross-checked against a 3D Karamba model of the arch. The rotational stiffness at reciprocal frame member joints in the model was a parameter that could be changed until global measurements in the model roughly matched those that were recorded for the as-built structure. This approach yielded an approximate rotational stiffness of 0.59 kN-m/rad (440 lb-ft/rad) (7.7 lb-ft/degree).

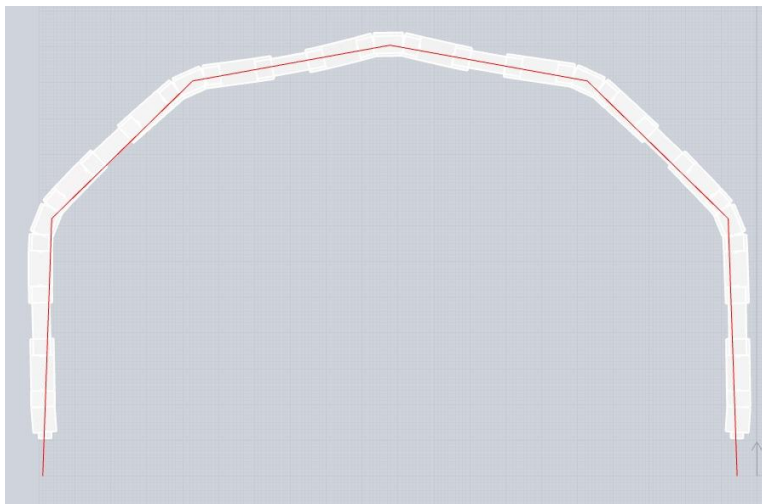

Another observation in the as-built structure was differential deflections between “arch planes” along the width of the arch. The center plane is the section of the arch located at half its width. The outer planes are the sections of the arch located at zero and full width. At the first “corner” of the arch between the ground, the center plane saw a deflection that was about 0.9” more inward compared to the outer planes. At the crown of the arch, however, the center plane saw a deflection that was about 1.8” more outward (upward) compared to the outer planes. This demonstrates that the stiffest loadpath in the as-built arch under self-weight approximated an “X” stretching from one end of the arch to the other end along its line segments.

The as-built measurements at the “corners” of the arch (averaged on its width) were as follows:

	Horizontal Dist. Between Points	Vertical Dist. Above Ground
Base Plates	193.5”	10”
First “Corners”	188.5”	72”
Second/Upper “Corners”	110.0”	110.5”
Crown/Top “Corners”	-	120.5”

CHAPTER 27

WIND LOADS ON BUILDINGS: MAIN WIND FORCE RESISTING SYSTEM (DIRECTIONAL PROCEDURE)

27.1 SCOPE

27.1.1 Building Types. This chapter applies to the determination of main wind force resisting system (MWFRS) wind loads on enclosed, partially enclosed, and open buildings of all heights using the Directional Procedure.

Part 1 applies to buildings of all heights where it is necessary to separate applied wind loads onto the windward, leeward, and sidewalls of the building to properly assess the internal forces in the MWFRS members.

Part 2 applies to a special class of buildings designated as enclosed simple diaphragm buildings, as defined in Section 26.2, with $h \leq 160$ ft ($h \leq 48.8$ m).

27.1.2 Conditions. A building that has design wind loads determined in accordance with this chapter shall comply with all of the following conditions:

1. The building is a regular-shaped building as defined in Section 26.2, and
2. The building does not have response characteristics that make it subject to across-wind loading, vortex shedding, or instability caused by galloping or flutter; nor does it have a site location for which channeling effects or buffeting in the wake of upwind obstructions warrant special consideration.

27.1.3 Limitations. The provisions of this chapter take into consideration the load magnification effect caused by gusts in resonance with along-wind vibrations of flexible buildings. Buildings that do not meet the requirements of Section 27.1.2 or that have unusual shapes or response characteristics shall be designed using recognized literature documenting such wind load effects or shall use the Wind Tunnel Procedure specified in Chapter 31.

27.1.4 Shielding. There shall be no reductions in velocity pressure caused by apparent shielding afforded by buildings and other structures or terrain features.

27.1.5 Minimum Design Wind Loads. The wind load to be used in the design of the MWFRS for an enclosed or partially enclosed building shall not be less than 16 lb/ft^2 (0.77 kN/m^2) multiplied by the wall area of the building, and 8 lb/ft^2 (0.38 kN/m^2) multiplied by the roof area of the building projected onto a vertical plane normal to the assumed wind direction. Wall and roof loads shall be applied simultaneously. The design wind force for open buildings shall be not less than 16 lb/ft^2 (0.77 kN/m^2) multiplied by the area, A_f .

PART 1: ENCLOSED, PARTIALLY ENCLOSED, AND OPEN BUILDINGS OF ALL HEIGHTS

User Note: Use Part 1 of Chapter 27 to determine wind pressures on the MWFRS of enclosed, partially enclosed, or open buildings with any general plan shape, building height, or roof geometry that matches the figures provided. These provisions use the traditional “all heights” method (Directional Procedure) by calculating wind pressures using *specific wind pressure equations* applicable to each building surface.

27.2 GENERAL REQUIREMENTS

The steps to determine the wind loads on the MWFRS for enclosed, partially enclosed, and open buildings of all heights are provided in Table 27.2-1.

Table 27.2-1 Steps to Determine MWFRS Wind Loads for Enclosed, Partially Enclosed, and Open Buildings of All Heights

-
- Step 1:** Determine Risk Category of building; see Table 1.5-1.
- Step 2:** Determine the basic wind speed, V , for the applicable Risk Category; see Figs. 26.5-1 and 26.5-2.
- Step 3:** Determine wind load parameters:
- Wind directionality factor, K_d ; see Section 26.6 and Table 26.6-1.
 - Exposure category; see Section 26.7.
 - Topographic factor, K_{zt} ; see Section 26.8 and table in Fig. 26.8-1.
 - Ground elevation factor, K_e ; see Section 26.9.
 - Gust-effect factor, G or G_f ; see Section 26.11.
 - Enclosure classification; see Section 26.12.
 - Internal pressure coefficient, (GC_{pi}) ; see Section 26.13 and Table 26.13-1.
- Step 4:** Determine velocity pressure exposure coefficient, K_z or K_h ; see Table 26.10-1.
- Step 5:** Determine velocity pressure q_z or q_h , Eq. (26.10-1).
- Step 6:** Determine external pressure coefficient, C_p or C_N :
- Fig. 27.3-1 for walls and flat, gable, hip, monoslope, or mansard roofs.
 - Fig. 27.3-2 for domed roofs.
 - Fig. 27.3-3 for arched roofs.
 - Fig. 27.3-4 for monoslope roof, open building.
 - Fig. 27.3-5 for pitched roof, open building.
 - Fig. 27.3-6 for troughed roof, open building.
 - Fig. 27.3-7 for along-ridge/valley wind load case for monoslope, pitched, or troughed roof, open building.
- Step 7:** Calculate wind pressure, p , on each building surface:
- Eq. (27.3-1) for rigid and flexible buildings.
 - Eq. (27.3-2) for open buildings.
-

27.2.1 Wind Load Parameters Specified in Chapter 26. The following wind load parameters shall be determined in accordance with Chapter 26:

- Basic wind speed, V (Section 26.5).
- Wind directionality factor, K_d (Section 26.6).
- Exposure category (Section 26.7).
- Topographic factor, K_{zt} (Section 26.8).
- Ground elevation factor, K_e ; see Section 26.9.
- Gust-effect factor (Section 26.11).
- Enclosure classification (Section 26.12).
- Internal pressure coefficient, (GC_{pi}) (Section 26.13).

27.3 WIND LOADS: MAIN WIND FORCE RESISTING SYSTEM

27.3.1 Enclosed and Partially Enclosed Rigid and Flexible Buildings. Design wind pressures for the MWFRS of buildings of all heights in lb/ft^2 (N/m^2), shall be determined by the following equation:

$$p = qGC_p - q_i(GC_{pi}) \quad (27.3-1)$$

where

$q = q_z$ for windward walls evaluated at height z above the ground.

$q = q_h$ for leeward walls, sidewalls, and roofs evaluated at height h .

$q_i = q_h$ for windward walls, sidewalls, leeward walls, and roofs of enclosed buildings, and for negative internal pressure evaluation in partially enclosed buildings.

$q_i = q_z$ for positive internal pressure evaluation in partially enclosed buildings where height z is defined as the level of the highest opening in the building that could affect the positive internal pressure. For buildings sited in wind-borne debris regions, glazing that is not impact-resistant or protected with an impact-resistant covering shall be treated as an opening in accordance with Section 26.12.3. For positive internal pressure evaluation, q_i may conservatively be evaluated at height h ($q_i = q_h$).

G = gust-effect factor; see Section 26.11. For flexible buildings, G_f determined in accordance with Section 26.11.5 shall be substituted for G .

C_p = external pressure coefficient from Figs. 27.3-1, 27.3-2, and 27.3-3.

(GC_{pi}) = internal pressure coefficient from Table 26.13-1.

Both q and q_i shall be evaluated using exposure defined in Section 26.7.3. Pressure shall be applied simultaneously on windward and leeward walls and on roof surfaces as defined in Figs. 27.3-1, 27.3-2, and 27.3-3.

27.3.2 Open Buildings with Monoslope, Pitched, or Troughed Free Roofs. The net design pressure for the MWFRS of open buildings with monoslope, pitched, or troughed free roofs in lb/ft^2 (N/m^2), shall be determined by the following equation:

$$p = q_h GC_N \quad (27.3-2)$$

where

q_h = velocity pressure evaluated at mean roof height h using the exposure as defined in Section 26.7.3 that results in the highest wind loads for any wind direction at the site.

G = gust-effect factor from Section 26.11.

C_N = net pressure coefficient determined from Figs. 27.3-4 through 27.3-7.

Net pressure coefficients, C_N , include contributions from top and bottom surfaces. All load cases shown for each roof angle shall be investigated. Plus and minus signs signify pressure acting toward and away from the top surface of the roof, respectively.

For free roofs with an angle of plane of roof from horizontal θ less than or equal to 5° and containing fascia panels, the fascia panel shall be considered an inverted parapet. The contribution of loads on the fascia to the MWFRS loads shall be determined using Section 27.3.5, with q_p equal to q_h . For an open or partially enclosed building with transverse frames and a pitched roof ($\theta \leq 45^\circ$), an additional horizontal force in the longitudinal direction (parallel to the ridge) that acts in combination with the roof load calculated in Section 27.3.3 shall be determined in accordance with Section 28.3.5.

27.3.3 Roof Overhangs. The positive external pressure on the bottom surface of windward roof overhangs shall be determined using $C_p = 0.8$ and combined with the top surface pressures determined using Fig. 27.3-1.

27.3.4 Parapets. The design wind pressure for the effect of parapets on MWFRS of rigid or flexible buildings with flat, gable, or hip roofs in lb/ft^2 (N/m^2), shall be determined by the following equation:

$$p_p = q_p(GC_{pn})(\text{lb}/\text{ft}^2) \quad (27.3-3)$$

where

p_p = combined net pressure on the parapet caused by the combination of the net pressures from the front and back parapet surfaces. Plus (and minus) signs signify net pressure acting toward (and away from) the front (exterior) side of the parapet.

q_p = velocity pressure evaluated at the top of the parapet.

(GC_{pn}) = combined net pressure coefficient:

= +1.5 for windward parapet or

= -1.0 for leeward parapet.

27.3.5 Design Wind Load Cases. The MWFRS of buildings of all heights, the wind loads of which have been determined under the provisions of this chapter, shall be designed for the wind load cases as defined in Fig. 27.3-8.

EXCEPTION: Buildings meeting the requirements of Section D1.1 of Appendix D need only be designed for Case 1 and Case 3 of Fig. 27.3-8.

The eccentricity e for rigid buildings shall be measured from the geometric center of the building face and shall be considered for each principal axis (e_x , e_y). The eccentricity e for flexible buildings shall be determined from the following equation and shall be considered for each principal axis (e_x , e_y):

$$e = \frac{e_Q + 1.7I_z \sqrt{(g_Q Q e_Q)^2 + (g_R R e_R)^2}}{1 + 1.7I_z \sqrt{(g_Q Q)^2 + (g_R R)^2}} \quad (27.3-4)$$

where

e_Q = eccentricity e as determined for rigid buildings in Fig. 27.3-8.

e_R = distance between the elastic shear center and center of mass of each floor.

I_z , g_Q , Q , g_R , and R shall be as defined in Section 26.11.

The sign of the eccentricity e shall be plus or minus, whichever causes the more severe load effect.

Table 26.6-1 Wind Directionality Factor, K_d

Structure Type	Directionality Factor K_d
Buildings	
Main Wind Force Resisting System	0.85
Components and Cladding	0.85
Arched Roofs	0.85
Circular Domes	1.0 ^a
Chimneys, Tanks, and Similar Structures	
Square	0.90
Hexagonal	0.95
Octagonal	1.0 ^a
Round	1.0 ^a
Solid Freestanding Walls, Roof Top Equipment, and Solid Freestanding and Attached Signs	
Open Signs and Single-Plane Open Frames	0.85
Trussed Towers	
Triangular, square, or rectangular	0.85
All other cross sections	0.95

^aDirectionality factor $K_d=0.95$ shall be permitted for round or octagonal structures with nonaxisymmetric structural systems.

26.6 WIND DIRECTIONALITY

The wind directionality factor, K_d , shall be determined from Table 26.6-1 and shall be included in the wind loads calculated in Chapters 27 to 30. The effect of wind directionality in determining wind loads in accordance with Chapter 31 shall be based on a rational analysis of the wind speeds conforming to the requirements of Section 26.5.3 and of Section 31.4.3.

26.7 EXPOSURE

For each wind direction considered, the upwind exposure shall be based on ground surface roughness that is determined from natural topography, vegetation, and constructed facilities.

26.7.1 Wind Directions and Sectors. For each selected wind direction at which the wind loads are to be determined, the exposure of the building or structure shall be determined for the two upwind sectors extending 45° on either side of the selected wind direction. The exposure in these two sectors shall be determined in accordance with Sections 26.7.2 and 26.7.3, and the exposure the use of which would result in the highest wind loads shall be used to represent the winds from that direction.

26.7.2 Surface Roughness Categories. A ground surface roughness within each 45° sector shall be determined for a distance upwind of the site, as defined in Section 26.7.3, from the categories defined in the following text, for the purpose of assigning an exposure category as defined in Section 26.7.3.

Surface Roughness B: Urban and suburban areas, wooded areas, or other terrain with numerous, closely spaced obstructions that have the size of single-family dwellings or larger.

Surface Roughness C: Open terrain with scattered obstructions that have heights generally less than 30 ft (9.1 m). This category includes flat, open country and grasslands.

Surface Roughness D: Flat, unobstructed areas and water surfaces. This category includes smooth mud flats, salt flats, and unbroken ice.

26.7.3 Exposure Categories.

Exposure B: For buildings or other structures with a mean roof height less than or equal to 30 ft (9.1 m), Exposure B shall apply where the ground surface roughness, as defined by Surface Roughness B, prevails in the upwind direction for a distance greater than 1,500 ft (457 m). For buildings or other structures with a mean roof height greater than 30 ft (9.1 m), Exposure B shall apply where Surface Roughness B prevails in the upwind direction for a distance greater than 2,600 ft (792 m) or 20 times the height of the building or structure, whichever is greater.

Exposure C: Exposure C shall apply for all cases where Exposure B or D does not apply.

Exposure D: Exposure D shall apply where the ground surface roughness, as defined by Surface Roughness D, prevails in the upwind direction for a distance greater than 5,000 ft (1,524 m) or 20 times the building or structure height, whichever is greater. Exposure D shall also apply where the ground surface roughness immediately upwind of the site is B or C, and the site is within a distance of 600 ft (183 m) or 20 times the building or structure height, whichever is greater, from an Exposure D condition as defined in the previous sentence.

For a site located in the transition zone between exposure categories, the category resulting in the largest wind forces shall be used.

EXCEPTION: An intermediate exposure between the preceding categories is permitted in a transition zone, provided that it is determined by a rational analysis method defined in the recognized literature.

26.7.4 Exposure Requirements.

26.7.4.1 Directional Procedure (Chapter 27). For each wind direction considered, wind loads for the design of the MWFRS of enclosed and partially enclosed buildings using the Directional Procedure of Chapter 27 shall be based on the exposures as defined in Section 26.7.3. Wind loads for the design of open buildings with monoslope, pitched, or troughed free roofs shall be based on the exposures, as defined in Section 26.7.3, resulting in the highest wind loads for any wind direction at the site.

26.7.4.2 Envelope Procedure (Chapter 28). Wind loads for the design of the MWFRS for all low-rise buildings designed using the Envelope Procedure of Chapter 28 shall be based on the exposure category resulting in the highest wind loads for any wind direction at the site.

26.7.4.3 Directional Procedure for Building Appurtenances and Other Structures (Chapter 29). Wind loads for the design of building appurtenances (such as rooftop structures and equipment) and other structures (such as solid freestanding walls and freestanding signs, chimneys, tanks, open signs, single-plane open frames, and trussed towers) as specified in Chapter 29 shall be based on the appropriate exposure for each wind direction considered.

26.7.4.4 Components and Cladding (Chapter 30). Design wind pressures for C&C shall be based on the exposure category resulting in the highest wind loads for any wind direction at the site.

26.8 TOPOGRAPHIC EFFECTS

26.8.1 Wind Speed-Up over Hills, Ridges, and Escarpments. Wind speed-up effects at isolated hills, ridges, and escarpments constituting abrupt changes in the general topography, located in any exposure category, shall be included in the determination of the wind loads when site

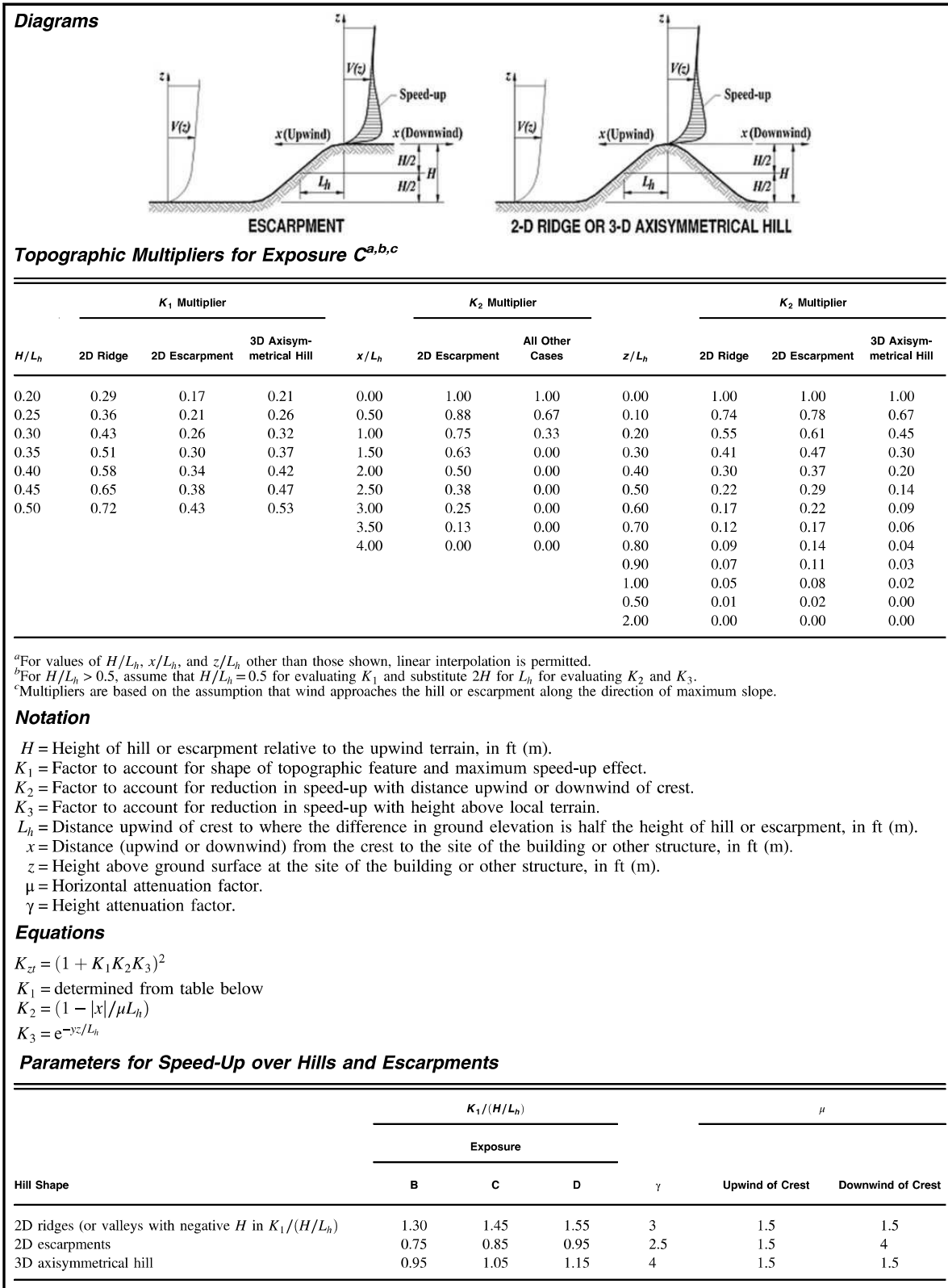

FIGURE 26.8-1 Topographic Factor, K_{zt}

conditions and locations of buildings and other structures meet all of the following conditions:

1. The hill, ridge, or escarpment is isolated and unobstructed upwind by other similar topographic features of comparable height for 100 times the height of the topographic feature ($100H$) or 2 mi (3.22 km), whichever is less. This distance shall be measured horizontally from the point at which the height H of the hill, ridge, or escarpment is determined.
2. The hill, ridge, or escarpment protrudes above the height of upwind terrain features within a 2-mi (3.22-km) radius in any quadrant by a factor of 2 or more.
3. The building or other structure is located as shown in Fig. 26.8-1 in the upper one-half of a hill or ridge or near the crest of an escarpment.
4. $H/L_h \geq 0.2$.
5. H is greater than or equal to 15 ft (4.5 m) for Exposure C and D and 60 ft (18 m) for Exposure B.

26.8.2 Topographic Factor. The wind speed-up effect shall be included in the calculation of design wind loads by using the factor K_{zt} :

$$K_{zt} = (1 + K_1 K_2 K_3)^2 \quad (26.8-1)$$

where K_1 , K_2 , and K_3 are given in Fig. 26.8-1.

If site conditions and locations of buildings and other structures do not meet all the conditions specified in Section 26.8.1, then $K_{zt} = 1.0$.

26.9 GROUND ELEVATION FACTOR

The ground elevation factor to adjust for air density, K_e , shall be determined in accordance with Table 26.9-1. It is permitted to take $K_e = 1$ for all elevations.

26.10 VELOCITY PRESSURE

26.10.1 Velocity Pressure Exposure Coefficient. Based on the exposure category determined in Section 26.7.3, a velocity pressure exposure coefficient, K_z or K_h , as applicable, shall be determined from Table 26.10-1. For a site located in a transition zone between exposure categories that is near to a change in ground surface roughness, intermediate values of K_z or K_h ,

Table 26.10-1 Velocity Pressure Exposure Coefficients, K_h and K_z

Height above Ground Level, z		Exposure		
ft	m	B	C	D
0–15	0–4.6	0.57 (0.70) ^a	0.85	1.03
20	6.1	0.62 (0.70) ^a	0.90	1.08
25	7.6	0.66 (0.70) ^a	0.94	1.12
30	9.1	0.70	0.98	1.16
40	12.2	0.76	1.04	1.22
50	15.2	0.81	1.09	1.27
60	18.0	0.85	1.13	1.31
70	21.3	0.89	1.17	1.34
80	24.4	0.93	1.21	1.38
90	27.4	0.96	1.24	1.40
100	30.5	0.99	1.26	1.43
120	36.6	1.04	1.31	1.48
140	42.7	1.09	1.36	1.52
160	48.8	1.13	1.39	1.55
180	54.9	1.17	1.43	1.58
200	61.0	1.20	1.46	1.61
250	76.2	1.28	1.53	1.68
300	91.4	1.35	1.59	1.73
350	106.7	1.41	1.64	1.78
400	121.9	1.47	1.69	1.82
450	137.2	1.52	1.73	1.86
500	152.4	1.56	1.77	1.89

^aUse 0.70 in Chapter 28, Exposure B, when $z < 30$ ft (9.1 m).

Notes

1. The velocity pressure exposure coefficient K_z may be determined from the following formula:
For $15 \text{ ft (4.6 m)} \leq z \leq z_g$ $K_z = 2.01(z/z_g)^{2/\alpha}$
For $z < 15 \text{ ft (4.6 m)}$ $K_z = 2.01(15/z_g)^{2/\alpha}$
2. α and z_g are tabulated in Table 26.11-1.
3. Linear interpolation for intermediate values of height z is acceptable.
4. Exposure categories are defined in Section 26.7.

between those shown in Table 26.10-1 are permitted provided that they are determined by a rational analysis method defined in the recognized literature.

26.10.2 Velocity Pressure. Velocity pressure, q_z , evaluated at height z above ground shall be calculated by the following equation:

$$q_z = 0.00256 K_z K_{zt} K_d K_e V^2 \text{ (lb/ft}^2\text{); } V \text{ in mi/h} \quad (26.10-1)$$

$$q_z = 0.613 K_z K_{zt} K_d K_e V^2 \text{ (N/m}^2\text{); } V \text{ in m/s} \quad (26.10-1.si)$$

where

- K_z = velocity pressure exposure coefficient, see Section 26.10.1.
- K_{zt} = topographic factor, see Section 26.8.2.
- K_d = wind directionality factor, see Section 26.6.
- K_e = ground elevation factor, see Section 26.9.
- V = basic wind speed, see Section 26.5.
- q_z = velocity pressure at height z .

The velocity pressure at mean roof height is computed as $q_h = q_z$ evaluated from Eq. (26.10-1) using K_z at mean roof height h .

The basic wind speed, V , used in determination of design wind loads on rooftop structures, rooftop equipment, and other

Table 26.9-1 Ground Elevation Factor, K_e

Ground Elevation above Sea Level		Ground Elevation Factor K_e
ft	m	
<0	<0	See note 2
0	0	1.00
1,000	305	0.96
2,000	610	0.93
3,000	914	0.90
4,000	1,219	0.86
5,000	1,524	0.83
6,000	1,829	0.80
>6,000	>1,829	See note 2

Notes

1. The conservative approximation $K_e = 1.00$ is permitted in all cases.
2. The factor K_e shall be determined from the above table using interpolation or from the following formula for all elevations:
 $K_e = e^{-0.0000362z_g}$ (z_g = ground elevation above sea level in ft).
 $K_e = e^{-0.000119z_g}$ (z_g = ground elevation above sea level in m).
3. K_e is permitted to be taken as 1.00 in all cases.

External Pressure Coefficient, C_p				
Conditions	Rise-to-Span Ratio, r	C_p		
		Windward Quarter	Center Half	Leeward Quarter
Roof on elevated structure	$0 < r < 0.2$	-0.9	$-0.7 - r$	-0.5
	$0.2 \leq r < 0.3^a$	$1.5r - 0.3$	$-0.7 - r$	0.5
	$0.3 \leq r \leq 0.6$	$2.75r - 0.7$	$-0.7 - r$	0.5
Roof springing from ground level	$0 < r \leq 0.6$	$1.4r$	$-0.7 - r$	0.5

^aWhen the rise-to-span ratio is $0.2 \leq r \leq 0.3$, alternate coefficients given by $6r - 2.1$ shall also be used for the windward quarter.

Notes

1. Values listed are for the determination of average loads on main wind-force resisting systems.
2. Plus and minus signs signify pressures acting toward and away from the surfaces, respectively.
3. For wind directed parallel to the axis of the arch, use pressure coefficients from Fig. 27.3-1 with wind directed parallel to ridge.
4. For components and cladding (1) at roof perimeter, use the external pressure coefficients in Fig. 30.3-2A, B, and C with θ based on springline slope and (2) for remaining roof areas, use external pressure coefficients of this table multiplied by 1.2.

FIGURE 27.3-3 Main Wind Force Resisting System and Components and Cladding, Part 1 (All Heights): External Pressure Coefficients, C_p , for Enclosed and Partially Enclosed Buildings and Structures—Arched Roofs

Table 26.13-1 Main Wind Force Resisting System and Components and Cladding (All Heights): Internal Pressure Coefficient, (GC_{pi}), for Enclosed, Partially Enclosed, Partially Open, and Open Buildings (Walls and Roof)

Enclosure Classification	Criteria for Enclosure Classification	Internal Pressure	Internal Pressure Coefficient, (GC_{pi})
Enclosed buildings	A_o is less than the smaller of $0.01A_g$ or 4 sq ft (0.37 m) and $A_{oi}/A_{gi} \leq 0.2$	Moderate	+0.18 -0.18
Partially enclosed buildings	$A_o > 1.1A_{oi}$ and $A_o >$ the lesser of $0.01A_g$ or 4 sq ft (0.37 m) and $A_{oi}/A_{gi} \leq 0.2$	High	+0.55 -0.55
Partially open buildings	A building that does not comply with Enclosed, Partially Enclosed, or Open classifications	Moderate	+0.18 -0.18
Open buildings	Each wall is at least 80% open	Negligible	0.00

Notes

1. Plus and minus signs signify pressures acting toward and away from the internal surfaces, respectively.
2. Values of (GC_{pi}) shall be used with q_z or q_h as specified.
3. Two cases shall be considered to determine the critical load requirements for the appropriate condition:
 - a. A positive value of (GC_{pi}) applied to all internal surfaces, or
 - b. A negative value of (GC_{pi}) applied to all internal surfaces.

EXCEPTION: Other testing methods and/or performance criteria are permitted to be used when approved.

Glazing and impact-protective systems in buildings and other structures classified as Risk Category IV in accordance with Section 1.5 shall comply with the “enhanced protection” requirements of Table 3 of ASTM E1996. Glazing and impact-protective systems in all other structures shall comply with the “basic protection” requirements of Table 3 of ASTM E1996.

26.12.4 Multiple Classifications. If a building by definition complies with both the “open” and “partially enclosed” definitions, it shall be classified as an “open” building.

26.13 INTERNAL PRESSURE COEFFICIENTS

Internal pressure coefficients, (GC_{pi}), shall be determined from Table 26.13-1 based on building enclosure classifications determined from Section 26.12.

26.13.1 Reduction Factor for Large-Volume Buildings, R_i . For a partially enclosed building containing a single, unpartitioned large volume, the internal pressure coefficient, (GC_{pi}), shall be multiplied by the following reduction factor, R_i :

$$R_i = 1.0 \quad \text{or} \quad R_i = 0.5 \left(1 + \frac{1}{\sqrt{1 + \frac{V_i}{22,800A_{og}}}} \right) < 1.0 \quad (26.13-1)$$

where

A_{og} = total area of openings in the building envelope (walls and roof, in ft^2); and

V_i = unpartitioned internal volume, in ft^3 .

26.14 TORNADO LIMITATION

Tornadoes have not been considered in the wind load provisions.

26.15 CONSENSUS STANDARDS AND OTHER REFERENCED DOCUMENTS

This section lists the consensus standards and other documents that shall be considered part of this standard to the extent referenced in this chapter.

AAMA 512, *Voluntary Specifications for Tornado Hazard Mitigating Fenestration Products*, American Architectural Manufacturers Association, 2011.

Cited in: C26.14.4

ANSI A58.1, *Minimum Design Loads for Buildings and Other Structures*, American National Standards Institute, 1982.

Cited in: Section C26.5.2

ASTM E1886, *Standard test method for performance of exterior windows, curtain walls, doors, and impact protective systems impacted by missile(s) and exposed to cyclic pressure differentials*, ASTM International, 2013.

Cited in: Section 26.12.3.2, C26.12, C26.14.4.

ASTM E1996, *Standard specification for performance of exterior windows, curtain walls, doors, and impact protective systems impacted by windborne debris in hurricanes*, ASTM International, 2014.

Cited in: Section 26.12.3.2, C26.12, C26.14.4.

ANSI/DASMA 115, *Standard Method for Testing Sectional Garage Doors: Determination of Structural Performance under Missile Impact and Cyclic Wind Pressure*, Door and Access Systems Manufacturers Association International, 2005.

Cited in: Section 26.12.3.2, C26.12.

ASTM E330, *Standard Test Method for Structural Performance of Exterior Windows, Doors, Skylights, and Curtain Walls by Uniform Static Air Pressure Difference*, ASTM International, 2014.

Cited in: Section C26.5.1

CAN/CSA A123.21, *Standard test method for the dynamic wind uplift resistance of membrane-roofing systems*, CSA Group, 2014.

Cited in: Section C26.5.1

ICC 500, *ICC/NSSA Standard for the Design and Construction of Storm Shelters*, International Code Council and National Storm Shelter Association, 2014.

Cited in: Section C26.14.1, C26.14.3, C26.14.4

WIND LOADING:

Kz	velocity pressure exposure coefficient	0.57	exposure B	p (psf)	GCpi			
Kzt	topographic factor	1.00	no escarpment/hill		0	0		
Kd	directionality factor	0.85	arched roof	0.84	7.2	7.2	windward quarter, arched roof	
Ke	ground elevation factor	1.00	elevation about 150'	Cp	-1.30	-11.1	-11.1	center half, arched roof
V	basic wind speed	mph	90		0.50	4.3	4.3	leeward quarter, arched roof
qh	velocity pressure at mean height	psf	10.0	mean height of 7'				
G	gust effect factor	0.85	rigid building	<i>times arch width 6.8'</i>				
Cp	external pressure coefficients	0.84	windward quarter, arched roof	p (plf)	49	49	windward quarter, arched roof	
			-1.3		center half, arched roof	-75	-75	center half, arched roof
			0.5		leeward quarter, arched roof	29	29	leeward quarter, arched roof
GCpi	internal pressure coefficients	0	open	<i>times area factor</i>				
		0	open	p (plf)	24	24		
					-38	-38		
					15	15		

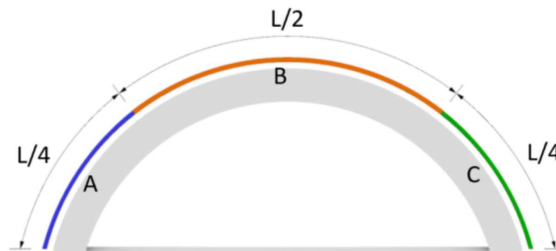

CONSIDERED LOCATION:
Highland Park, 2025 Broadway St. NE, Salem, OR

SELF WEIGHT ONLY (Polycarbonate Sheets + Marine Ply @ 37 pcf):

NORMAL:

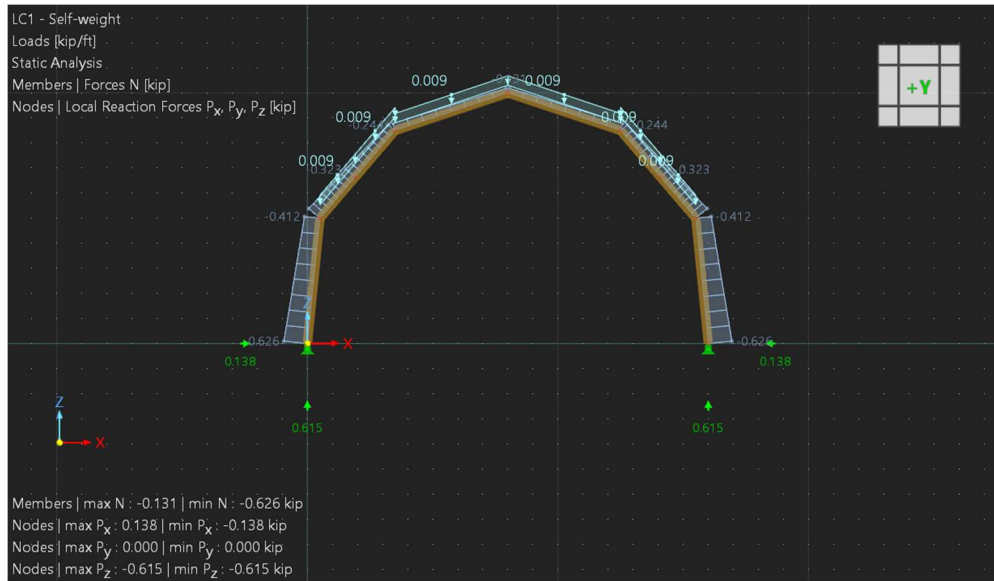

SHEAR:

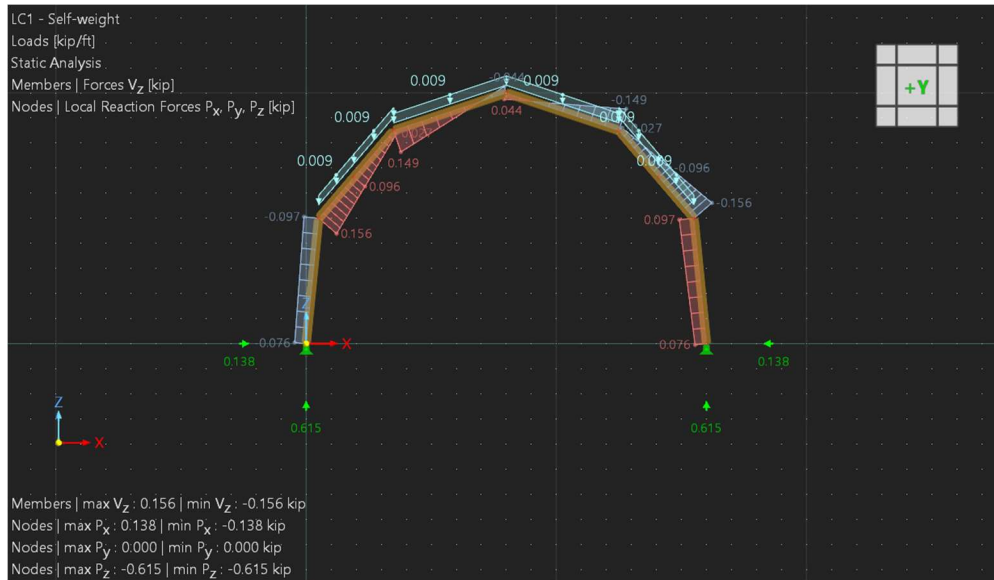

MOMENT:

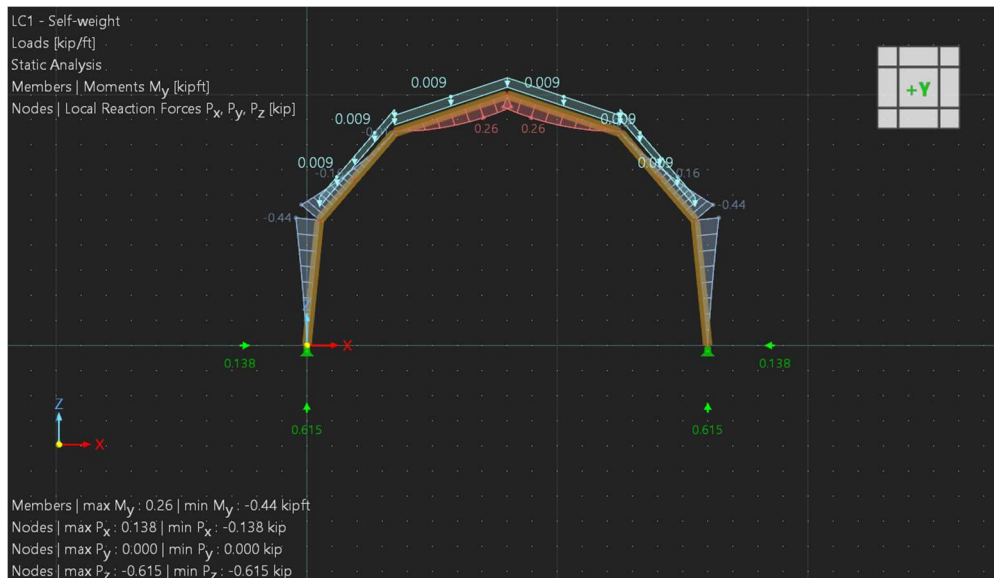

WIND 3 ONLY (Open Structure w/ perforated stiffening plates):

NORMAL:

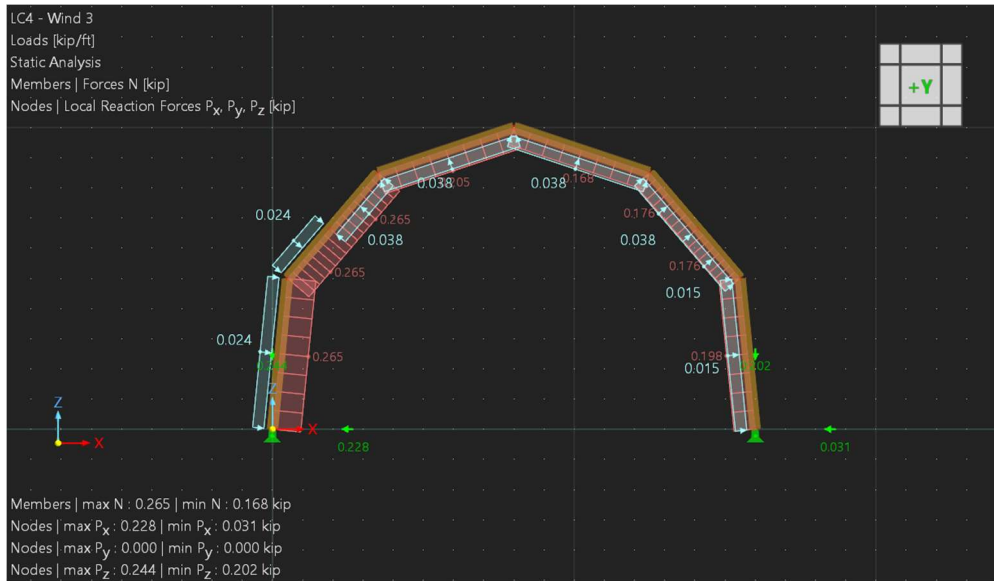

SHEAR:

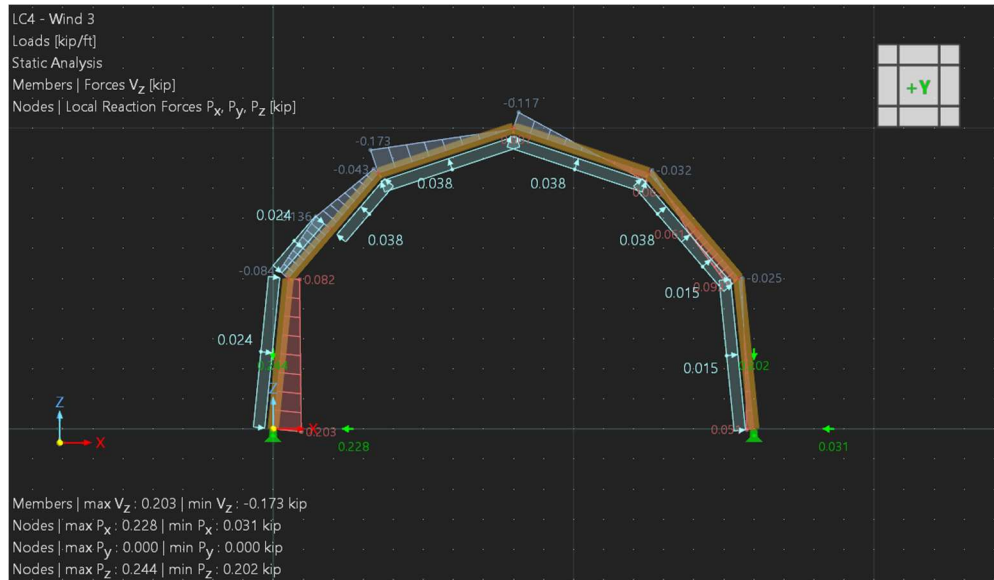

MOMENT:

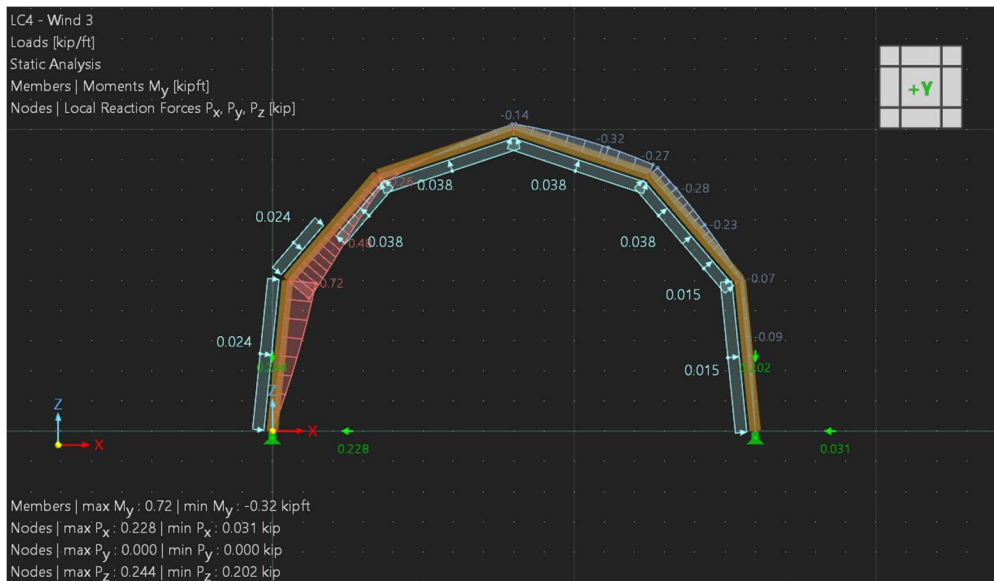

SELF WEIGHT (Polycarbonate Sheets + Marine Ply @ 37 pcf) + WIND 3 (Open Structure w/ perforated stiffening plates):

NORMAL:

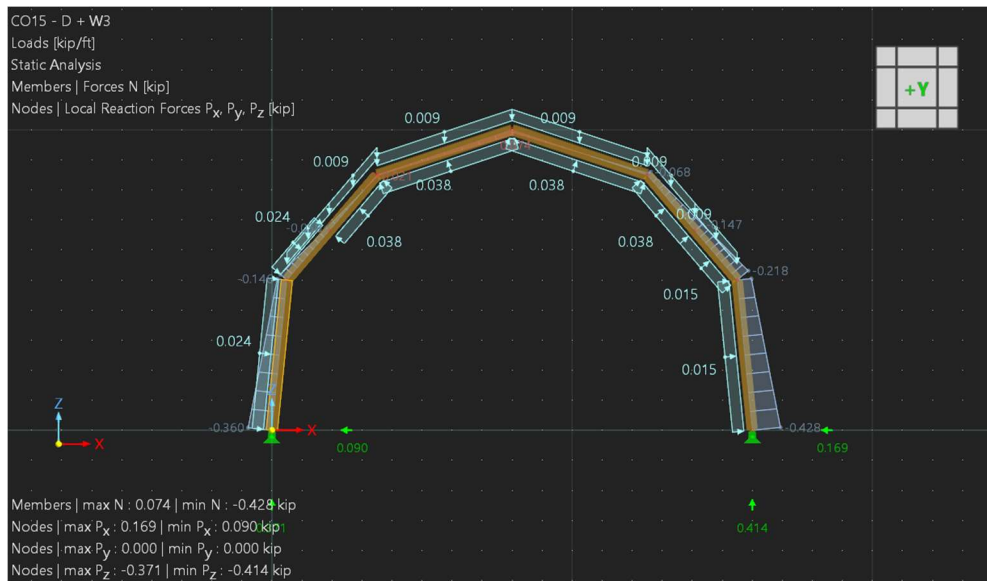

SHEAR:

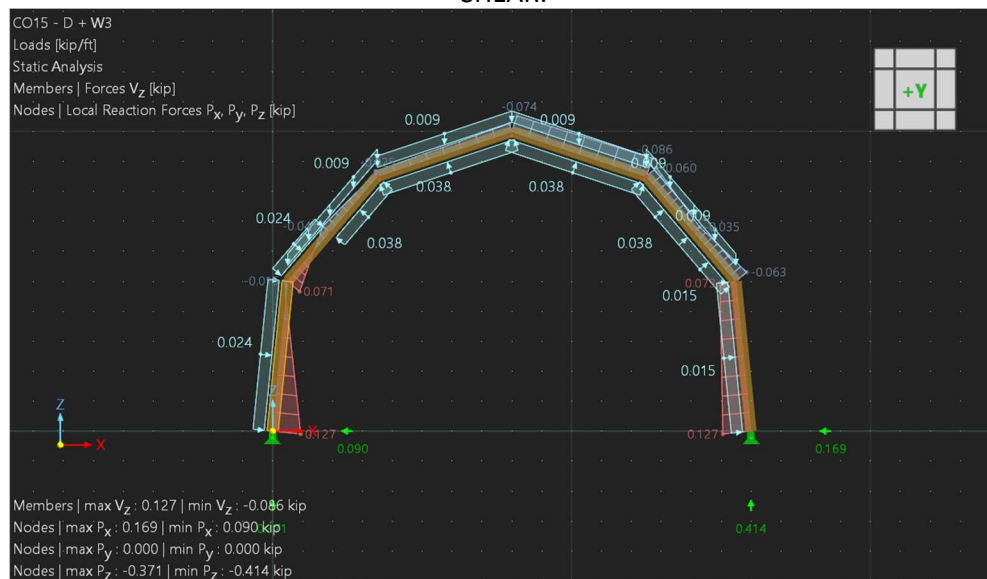

MOMENT:

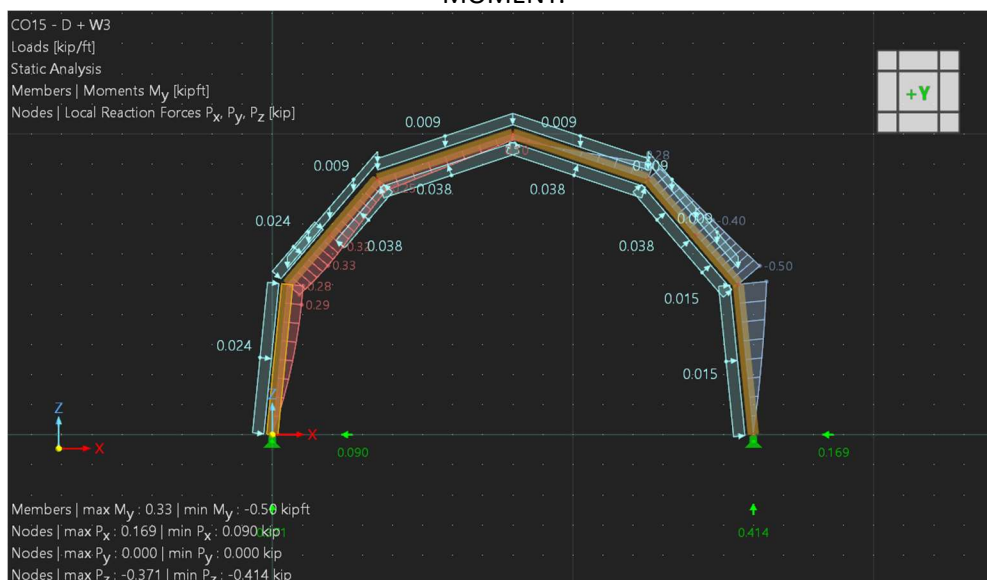

MAX INTERNAL FORCES:

max positive moment in arch	lb-ft	456	$0.6 \cdot D + W3$	at first "elbow"/corner
max positive moment per piece	lb-ft	76		
max negative moment in arch	lb-ft	-500	$D + W3$	at first "elbow"/corner
max negative moment per piece	lb-ft	-83		
max shear in arch	lb	157	$0.6 \cdot D + W3$	at base connection
max shear per piece	lb	26		
max compression in arch	lb	626	D	at base connection
max compression per piece	lb	104		
max tension in arch	lb	126	$0.6 \cdot D + W3$	at top "line segment"
max tension per piece	lb	21		

STRESS IN BENDING:

CD	load duration factor		0.9	conservative	
CM (Fv)	wet service factor for shear		0.97	conservative	
Fv	reference design value for shear	psi	188	23/32 marine grade ply	
F'v	adjusted design value for shear	psi	164		
b	breadth	in	0.71		
d	depth	in	5		
dn	notched depth	in	4		
d	overall depth at hole	in	6		
D	hole depth	in	4		
Vgross	allowable shear strength w/o hole	lb	388		
Vnet	allowable shear strength w/ hole	lb	43	OK	
V'r	adjusted design shear at notch	lb	199	OK	
Vmax	max shear	lb	26		
CD	load duration factor		0.9	conservative	
CM (Fc)	wet service factor for compression		0.75	conservative	
CM (Ft)	wet service factor for tension		0.75	conservative	
Ft	reference design value for tension	psi	538	23/32 marine grade ply	
F't	adjusted design value for tension	psi	363		
Fc	reference design value for compression	psi	503	23/32 marine grade ply	
F'c	adjusted design value for compression	psi	340		
F'b	adjusted design value for bending	psi	559	based on F't:F'b ratio of 0.65:1	
b	breadth	in	0.72		
d	depth	in	4		
y	distance to neutral axis	in	2		
I	moment of inertia	in ⁴	3.8		
A	cross sectional area	in ²	2.9		
Mmax+	max positive moment	lb-ft	76		
sigma1	bending stress	psi	475	OK	
Mmax-	max negative moment	lb-ft	-83		
sigma2	bending stress	psi	-519	OK	

SO, 4" TENON/MORTISE OK WITH 5" MEMBER DEPTH AT TENON AND 6" MEMBER DEPTH AT MORTISE

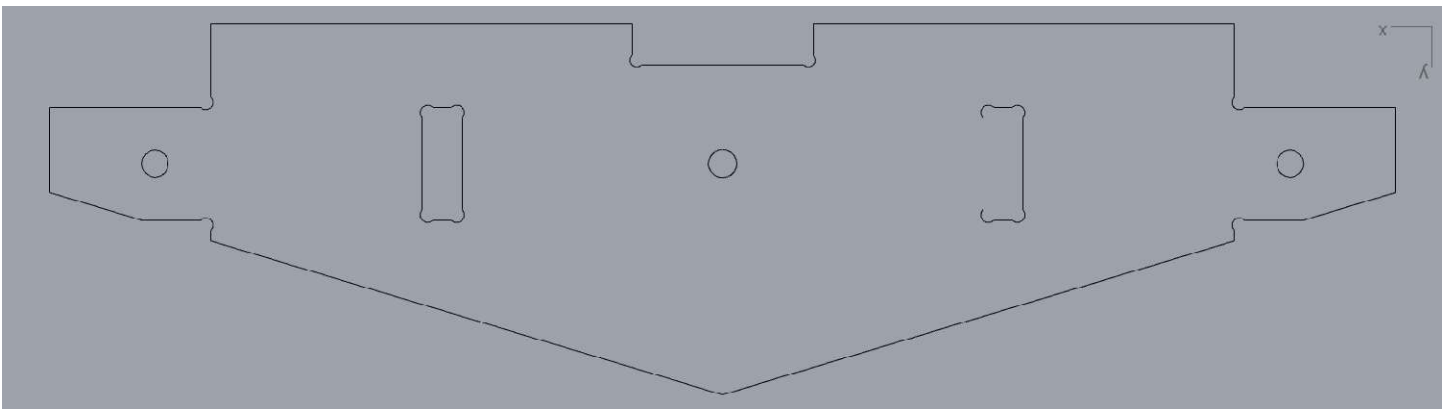

There is not a “minimum depth” for shear capacity at a notch, as this is a function of not only remaining depth but also notch depth ratio (as per NDS 2015 Section 3.4.3.2):

3.4.3.2 For notched bending members, shear force, V , shall be determined by principles of engineering mechanics (except those given in 3.4.3.1).

(a) For bending members with rectangular cross section and notched on the tension face (see 3.2.3), the adjusted design shear, V_r' , shall be calculated as follows:

$$V_r' = \left[\frac{2}{3} F_v' b d_n \right] \left[\frac{d_n}{d} \right]^2 \quad (3.4-3)$$

where:

d = depth of unnotched bending member, in.

d_n = depth of member remaining at a notch measured perpendicular to length of member, in.

F_v' = adjusted shear design value parallel to grain, psi

The same is true for shear capacity at a hole, and the following equation for LVL from (Yeh and Herzog, 2018) was assumed conservative for this case (since plywood has tension-perpendicular reinforcement while LVL does not):

As reported in *APA Report T2009L-30* [2], the hole adjustment factor for shear, $C_{hole,V}$, can be expressed as the square of the ratio of the depth remaining. Therefore, the net shear strength with a hole can be expressed in Equation 1.

$$V_{net} = C_{hole,V} V_{gross} = \left(\frac{d-D}{d} \right)^2 V_{gross} \quad (1)$$

where d is the LVL depth in mm (or inches), D is the hole diameter in mm (or inches), and V_{gross} is the full allowable shear strength of the LVL without a hole.

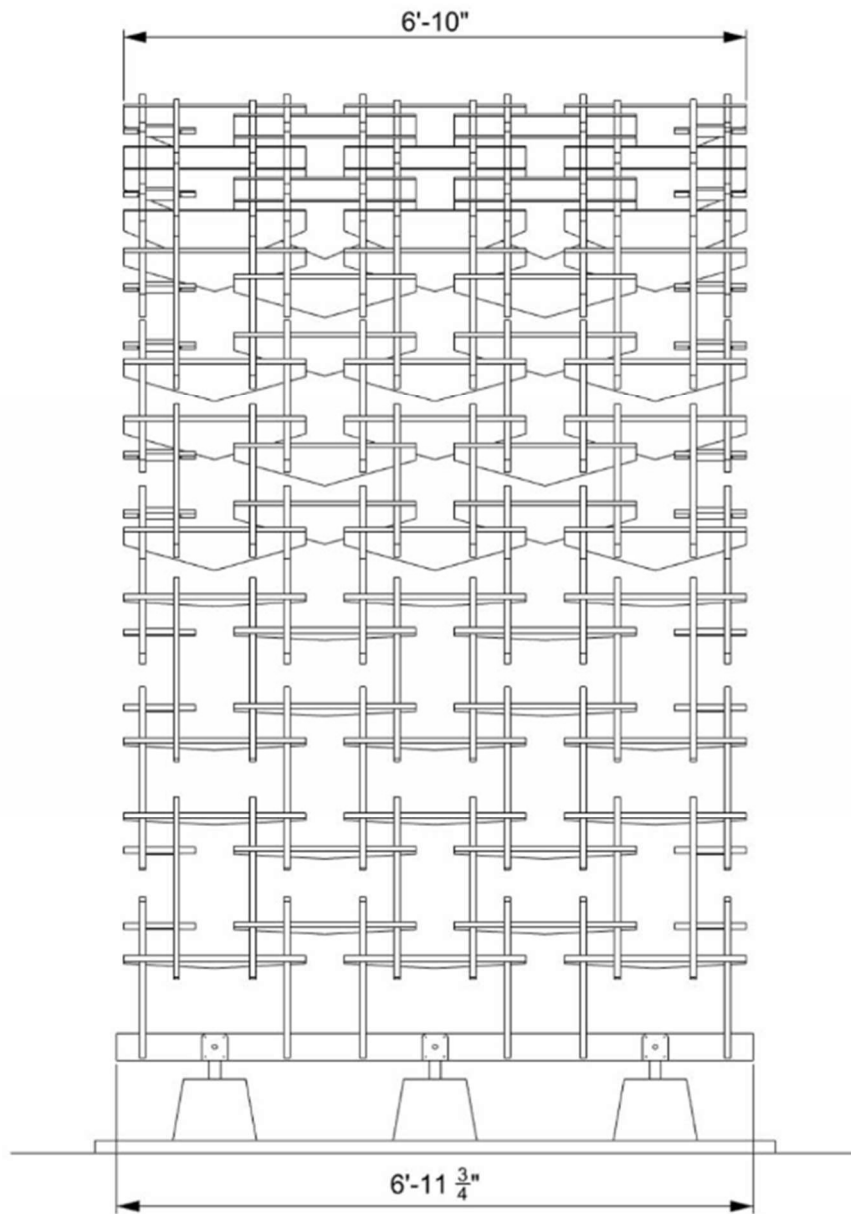

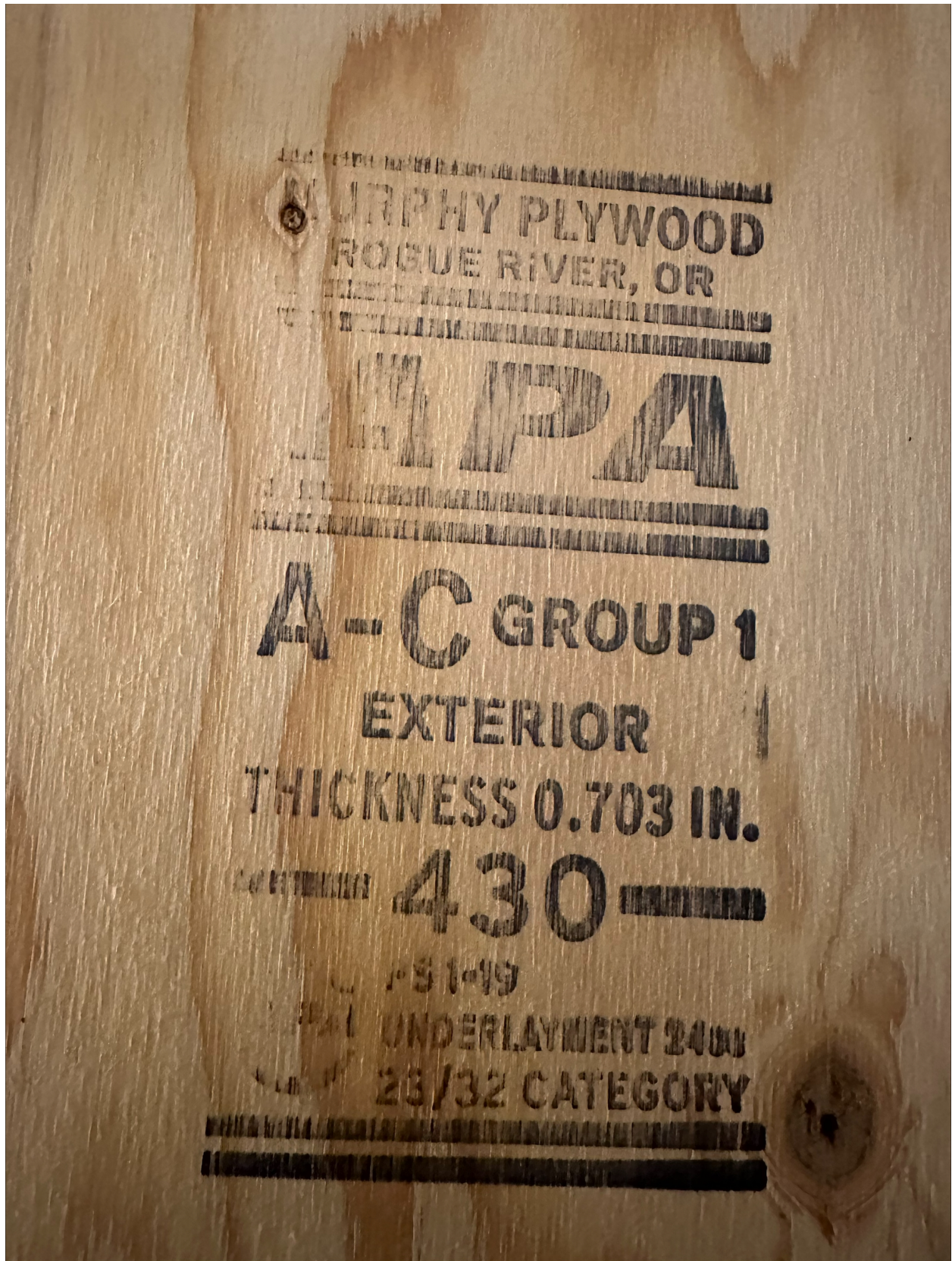

prescriptive provisions for other panel grades such as a variety of sanded plywood grades.

2.1.2. Voluntary Product Standard PS 2²,

Voluntary Product Standard PS 2², Performance Standard for Wood-Based Structural-Use Panels, was promulgated in 1992 as the first consensus-based performance standard for wood structural panels. The standard was based on APA’s PRP-108.

PS 2 is not limited to plywood, but applies to all wood-based structural panels in general, regardless of composition. It covers sheathing and single-floor grades only, and includes performance criteria, qualification requirements and test methods. Wood structural panels manufactured in conformance with PS 1

and PS 2 are recognized in all model building codes and most local codes in the United States. Also developed in concert with PS 2, with virtually identical provisions, was CSA-O325¹², Construction Sheathing, which is recognized in the National Building Code of Canada.

2.1.3. Proprietary standards

The prototype proprietary performance standard for wood structural panels is APA PRP-108, Performance Standards and Qualification Policy for Structural-Use Panels. The APA standard includes performance provisions for sheathing and single-floor grades, but also includes provisions for siding. Although PRP-108, promulgated in 1980, is quite mature, it remains in effect to take advantage of technical developments

more expeditiously than would be possible with the rather time-consuming consensus process required by PS 2.

2.2. Veneer

Wood veneer is at the heart of a plywood panel. The veneer used is classified according to species group and grade requirements of PS 1.

2.2.1. Species groups

While plywood can be manufactured from nearly any wood species, under PS 1 over 70 species of wood are rated for use based on strength and stiffness. This grouping into five Groups is presented in Table 1. Strongest species are in Group 1; the next strongest in Group 2, and so on. The Group number that appears in the trademark on most

TABLE 1

CLASSIFICATION OF SPECIES

Group 1	Group 2	Group 3	Group 4	Group 5
Apitong ^{(a)(b)}	Cedar, Port Orford	Maple, Black	Aspen	Basswood
Beech, American	Cypress	Mengkulang ^(a)	Bigtooth Quaking	Poplar, Balsam
Birch	Douglas-fir 2 ^(c)	Meranti, Red ^{(a)(d)}	Cedar, Alaska	
Sweet Yellow	Fir	Mersawa ^(a)	Fir, Subalpine	Cativo
Douglas-fir 1 ^(c)	Balsam California Red	Pine	Hemlock, Eastern	Cedar
Kapur ^(a)	Grand Noble	Pond Red	Maple, Bigleaf	Incense Western Red
Keruing ^{(a)(b)}	Pacific Silver White	Virginia Western White	Pine	Cottonwood
Larch, Western			Jack	Eastern Black (Western Poplar)
Maple, Sugar	Hemlock, Western	Spruce Black	Lodgepole	Pine
Pine	Lauan	Red	Ponderosa Spruce	Eastern White Sugar
Caribbean	Almon	Sitka	Redwood	
Ocote	Bagtikan	Sweetgum	Spruce	
Pine, Southern	Mayapis	Tamarack	Engelmann White	
Loblolly	Red Lauan	Yellow Poplar		
Longleaf	Tangile			
Shortleaf	White Lauan			
Slash				
Tanoak				

^(a) Each of these names represents a trade group of woods consisting of a number of closely related species.

^(b) Species from the genus *Dipterocarpus* marketed collectively: Apitong if originating in the Philippines, Keruing if originating in Malaysia or Indonesia.

^(c) Douglas-fir from trees grown in the states of Washington, Oregon, California, Idaho, Montana, Wyoming, and the Canadian Provinces of Alberta and British Columbia shall be classed as Douglas-fir No. 1. Douglas-fir from trees grown in the states of Nevada, Utah, Colorado, Arizona and New Mexico shall be classed as Douglas-fir No. 2.

^(d) Red Meranti shall be limited to species having a specific gravity of 0.41 or more based on green volume and oven dry weight.

Note: This version is superseded by a more current edition. Check the current edition for updated design and application recommendations.

panels marked as species Group 1, Table 4C provides multipliers for sanded panel capacities that are identified as species Group 2, 3 or 4. The tabulated capacities are based on data from tests of panels bearing the APA trademark. To take advantage of these capacities and adjustments, the specifier must insure that the correct panel is used in the final construction.

4.4.1. Panel flexure (flat panel bending)

Panel design capacities reported in Tables 4A and 4B are based on flat panel bending as measured by testing according to the principles of ASTM D 3043⁴ Method C (large panel testing). See Figure 4.

Stiffness (EI)

Panel bending stiffness is the capacity to resist deflection and is represented in bending equations as EI. The E is the modulus of elasticity of the material and the I is the moment of inertia of the cross section. Units of EI are lb-in.² per foot of panel width.

Strength (F_bS)

Allowable bending strength capacity is the design maximum moment, represented in bending equations as F_bS . Terms are the allowable extreme fiber stress of the material (F_b) and the section modulus (S). Units of F_bS are lb-in. per foot of panel width.

4.4.2. Panel axial strength

Tension (F_tA)

Allowable tension capacities are reported in Tables 4A and 4B based on testing according to the principles of ASTM D 3500⁵ Method B. Tension capacity is given as F_tA , where F_t is the allowable axial tension stress of the material and A is the area of the cross section. Units of F_tA are lb per foot of panel width.

Compression (F_cA)

Allowable compression capacities are reported in Tables 4A and 4B based on testing according to the principles of ASTM D 3501⁶ Method B. Compression capacity is given as F_cA , where F_c is the allowable axial compression stress of the material, and A is the area of the cross section. Units of F_cA are lb per foot of panel width. Axial compression strength is illustrated in Figure 5.

4.4.3. Panel axial stiffness (EA)

Panel axial stiffness is reported in Tables 4A and 4B based on testing according to the principles of ASTM D 3501⁶ Method B. Axial stiffness is the capacity to resist axial strain and is represented by EA. The E is the axial modulus of elasticity of the material and A is the area of the cross section. Units of EA are lb per foot of panel width.

4.4.4. Shear in the plane of the panel ($F_s[lb/Q]$)

Allowable shear in the plane of the panel (or interlaminar shear, sometimes called rolling shear in plywood) is reported in Tables 4A and 4B based on testing according to the principles of ASTM D 2718⁷. Shear strength in the plane of the panel is the capacity to resist horizontal shear breaking loads

when loads are applied or developed on opposite faces of the panel, as they are during flat panel bending. See Figure 6. The term F_s is the allowable material stress, while lb/Q is the panel cross sectional shear constant. Units of $F_s[lb/Q]$ are lb per foot of panel width.

4.4.5. Panel shear through the thickness

Panel shear-through-the-thickness capacities are reported based on testing according to the principles of ASTM D 2719⁸. See Figure 6.

Panel shear strength through the thickness (F_vt_v)

Allowable shear through the thickness is the capacity to resist horizontal shear breaking loads when loads are applied or developed on opposite edges of the panel, such as they are in an I-beam, and is reported in Tables 4A and 4B. See Figure 6. Where additional support is not provided to prevent buckling, design capacities in Tables 4A and 4B are limited to sections 2 ft or less in depth. Deeper sections may require additional reductions. The term F_v is the allowable stress of the material, while t_v is the effective panel thickness for shear. Units of F_vt_v are lb per inch of shear-resisting panel length.

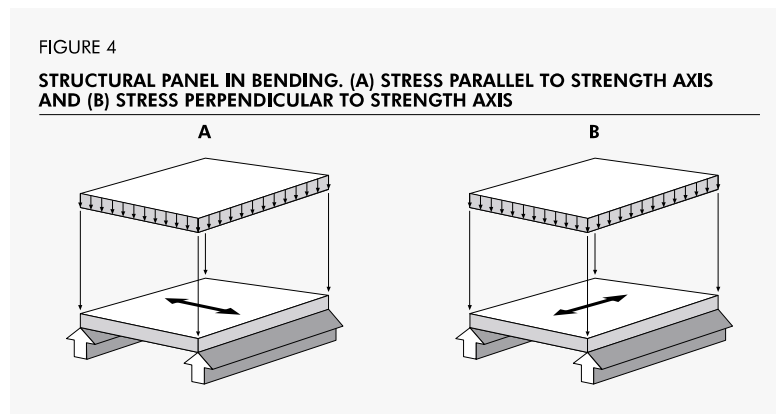

FIGURE 5

**STRUCTURAL PANEL WITH AXIAL
COMPRESSION LOAD IN THE PLANE OF THE PANEL**

FIGURE 6

**TWO TYPES OF PANEL SHEAR: SHEAR THROUGH THE THICKNESS
AND SHEAR IN THE PLANE OF THE PANEL**

**Panel rigidity through the thickness
($G_v t_v$)**

Panel rigidity is reported in Tables 4A and 4B and is the capacity to resist deformation when under shear-through-the-thickness stress. Rigidity is represented by $G_v t_v$, where G_v is the modulus of rigidity and t_v is the effective panel thickness for shear. The units of $G_v t_v$ are lb per inch of panel depth (for vertical applications). Multiplication of $G_v t_v$ by panel depth gives GA , used by designers for some applications.

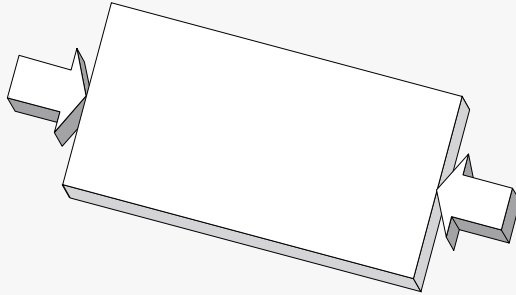
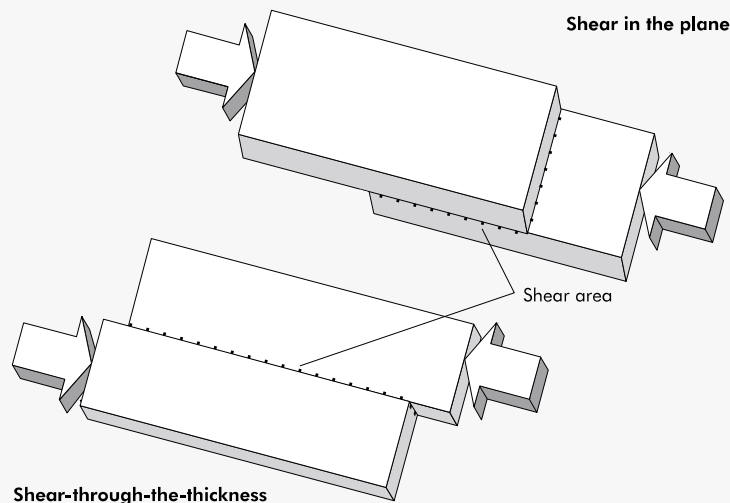
**4.4.6. Panel allowable bearing stress
($F_{c\perp}$)**

Bearing stress is the compression stress perpendicular to the plane of the plies or to the surface of the panel. As compression load is applied to panels (such as by columns or by reactions at supports), bearing stress is induced through the bearing area. The allowable bearing stress of APA structural-use panels is derived based on the load at a 0.04-in. [1.0 mm] deformation limit. A design bearing stress of 360 psi [2.5 N/mm²] shall be used for structural-use panels under dry-use conditions where moisture content is less than 16%. Multiplying the allowable bearing stress by the bearing area gives the bearing capacity, $F_{c\perp} A$, in pounds.

A reduced design bearing stress may be appropriate where bearing deformation could affect load distribution or where total deformation of members must be closely controlled. A conservative design value for 0.02-in. [0.5 mm] deformation

can be chosen as 50% of the allowable bearing stress at 0.04-in. [1.0 mm] deformation. If necessary, use the following regression equation to derive the design value for 0.02-in. [0.5 mm] deformation:

$$F_{c\perp 0.02"} = 0.51F_{c\perp 0.04"} + 28$$

4.4.7 Dowel bearing strength

Dowel bearing strength is a component in fastener yield equations, as found in the National Design Specification (NDS) for Wood Construction¹³. The yield equations are also sometimes referred to as the European Yield Model (EYM). Dowel bearing strength is measured by testing according to the principles of ASTM D 5764¹⁴.

Plywood trademarked Structural I or Marine grade can be taken as having a specific gravity of 0.50, based on the species limitations prescribed in PS 1. Plywood not identified as Structural I or Marine grade can be taken as having a specific gravity of 0.42, unless the species of plies is known, in which case the specific gravity listed for the actual species may be used. Dowel bearing strength of OSB listed below is conservative based on limited testing.

The table below summarizes dowel bearing strength of wood structural panels using terminology contained in the NDS.

Wood Structural Panel	Specific Gravity, G	Dowel Bearing Strength, F _e For Nailed Connections
Plywood		
Structural I, Marine	0.50	4650 psi [32 MPa]
Other grades ^(a)	0.42	3350 psi [23 MPa]
Oriented Strand Board		
All grades	0.50	4650 psi [32 MPa]

(a) Use G = 0.42 when species of the plies is not known. When species of the plies is known, specific gravity listed for the actual species and the corresponding dowel bearing strength may be used, or the weighted average may be used for mixed species.

4.5. Adjustments

Panel design capacities may be adjusted as required under the following provisions.

4.5.1. Duration of load (DOL)

Design capacities listed are based on “normal duration of load” as traditionally used for solid wood in accordance with U.S. Forest Products Laboratory Report R-1916⁹, and successfully used for plywood for approximately 40 years. Adjustment factors for strength capacities (C_D) are:

Time Under Load	DOL Adjustment Factor* (C _D)
Permanent	0.90
Normal	1.00
Two Months	1.15
Seven Days	1.25
Wind or Earthquake	1.60**

*Adjustment for impact load does not apply to structural-use panels.
**Check local building code.

Creep

Wood-based panels under constant load will creep (deflection will increase) over time. For typical construction applications, panels are not normally under constant load and, accordingly, creep need not be considered in design. When panels will sustain permanent loads that will stress the product to one-half or more of its design strength capacity,

allowance should be made for creep. Limited data indicates that under such conditions, creep may be taken into account in deflection calculations by applying the applicable following adjustment factor (C_C) to panel stiffness, EI:

Moisture Condition	Creep Adjustment Factor (C _C) for Permanent Loads	
	Plywood	OSB
Dry	1/2	1/2
16% m.c. or greater	1/2	1/6

See 4.5.2 for additional adjustments related to service moisture conditions, which for EI is cumulative with the adjustment for creep.

4.5.2. Service moisture conditions

Design capacities apply to panels under moisture conditions that are continuously dry in service; that is, where equilibrium moisture content is less than 16%. Adjustment factors for conditions where the panel moisture content in service is expected to be 16% or greater (C_m) are as follows:

Capacity	Moisture Content Adjustment Factor (C _m)
Strength (F _b S, F _v A, F _c A, F _s [lb/Q], F _v t _v)	0.75
Stiffness (EI, EA, G _v t _v)	0.85
Bearing (F _c ⊥A) Plywood	0.50
OSB	0.20

Note: This version is superseded by a more current edition. Check the current edition for updated design and application recommendations.

TABLE 4B

SANDED GROUP 1^(a) PLYWOOD DESIGN CAPACITIES

Nom. Thick	Stress Parallel to Strength Axis			Stress Perpendicular to Strength Axis		
	A-A, A-C	Marine	Other	A-A, A-C	Marine	Other
PANEL BENDING STIFFNESS, EI (lb-in.²/ft of panel width)						
1/4	15,000	15,000	15,000	700	980	700
1 1/32	34,000	34,000	34,000	1,750	2,450	1,750
3/8	49,000	49,000	49,000	2,750	3,850	2,750
15/32	120,000	120,000	120,000	11,000	15,500	11,000
1/2	140,000	140,000	140,000	15,500	21,500	15,500
19/32	205,000	205,000	205,000	37,500	52,500	37,500
5/8	230,000	230,000	230,000	48,500	68,000	48,500
23/32	320,000	320,000	320,000	90,500	125,000	90,500
3/4	355,000	355,000	355,000	115,000	160,000	115,000
7/8	500,000	500,000	500,000	185,000	260,000	185,000
1	760,000	760,000	760,000	330,000	460,000	330,000
1-1/8	985,000	985,000	985,000	490,000	685,000	490,000
Structural I Multiplier						
	1.0	1.0	1.0	1.4	1.0	1.4
PANEL BENDING STRENGTH, F_bS (lb-in./ft of panel width)						
1/4	115	105	95	17	20	14
1 1/32	185	170	155	31	36	26
3/8	245	225	205	44	52	37
15/32	425	390	355	130	150	110
1/2	470	430	390	175	205	145
19/32	625	570	520	270	315	225
5/8	670	615	560	325	380	270
23/32	775	710	645	455	530	380
3/4	815	750	680	565	660	470
7/8	1,000	935	850	780	910	650
1	1,300	1,200	1,100	1,150	1,350	975
1-1/8	1,600	1,500	1,350	1,500	1,750	1,250
Structural I Multiplier						
	1.0	1.0	1.1	1.4	1.0	1.4
PANEL AXIAL TENSION, F_tA (lb/ft of panel width)						
1/4	1,800	1,650	1,650	660	990	550
1 1/32	1,800	1,650	1,650	840	1,250	700
3/8	2,350	2,150	2,150	1,250	1,900	1,050
15/32	3,500	3,200	3,200	2,400	3,600	2,000
1/2	3,500	3,200	3,200	2,450	3,700	2,050
19/32	4,400	4,000	4,000	2,750	4,150	2,300
5/8	4,500	4,100	4,100	3,000	4,500	2,500
23/32	5,100	4,650	4,650	3,400	5,150	2,850
3/4	5,250	4,750	4,750	4,150	6,200	3,450
7/8	5,350	4,850	4,850	5,200	7,850	4,350
1	6,750	6,150	6,150	6,250	9,350	5,200
1-1/8	7,000	6,350	6,350	6,300	9,450	5,250
Structural I Multiplier						
	1.0	1.0	1.0	1.7	1.0	1.8

(a) See Table 4C for multipliers for other species Groups.

Note: This version is superseded by a more current edition. Check the current edition for updated design and application recommendations.

TABLE 4B (Continued)

SANDED GROUP 1^(a) PLYWOOD DESIGN CAPACITIES

Nom. Thick	Stress Parallel to Strength Axis			Stress Perpendicular to Strength Axis		
	A-A, A-C	Marine	Other	A-A, A-C	Marine	Other
PANEL AXIAL COMPRESSION F_cA (lb/ft of panel width)						
1/4	1,710	1,550	1,550	605	990	550
11/32	1,710	1,550	1,550	715	1,150	650
3/8	2,200	2,000	2,000	1,050	1,700	950
15/32	3,300	3,000	3,000	2,050	3,350	1,850
1/2	3,300	3,000	3,000	2,100	3,400	1,900
19/32	4,150	3,750	3,750	2,350	3,850	2,150
5/8	4,200	3,800	3,800	2,600	4,250	2,350
23/32	4,800	4,350	4,350	2,900	4,750	2,650
3/4	4,900	4,450	4,450	3,500	5,750	3,200
7/8	5,000	4,550	4,550	4,500	7,400	4,100
1	6,350	5,750	5,750	5,350	8,750	4,850
1-1/8	6,550	5,950	5,950	5,400	8,800	4,900
Structural I Multiplier						
	1.0	1.0	1.0	1.8	1.0	1.8
PANEL AXIAL STIFFNESS, EA (lb/ft of panel width)						
1/4	1,800,000	1,800,000	1,800,000	625,000	1,150,000	625,000
11/32	1,800,000	1,800,000	1,800,000	750,000	1,350,000	750,000
3/8	2,350,000	2,350,000	2,350,000	1,150,000	2,050,000	1,150,000
15/32	3,500,000	3,500,000	3,500,000	2,150,000	3,850,000	2,150,000
1/2	3,500,000	3,500,000	3,500,000	2,250,000	4,050,000	2,250,000
19/32	4,350,000	4,350,000	4,350,000	2,500,000	4,500,000	2,500,000
5/8	4,450,000	4,450,000	4,450,000	2,750,000	4,950,000	2,750,000
23/32	5,100,000	5,100,000	5,100,000	3,150,000	5,650,000	3,150,000
3/4	5,200,000	5,200,000	5,200,000	3,750,000	6,750,000	3,750,000
7/8	5,300,000	5,300,000	5,300,000	4,750,000	8,550,000	4,750,000
1	6,700,000	6,700,000	6,700,000	5,700,000	10,500,000	5,700,000
1-1/8	6,950,000	6,950,000	6,950,000	5,700,000	10,500,000	5,700,000
Structural I Multiplier						
	1.0	1.0	1.0	1.8	1.0	1.8
PANEL SHEAR IN THE PLANE, F_s(lb/Q) (lb/ft of panel width)						
1/4	105	135	105	105	135	105
11/32	145	190	145	145	190	145
3/8	165	215	165	165	215	165
15/32	220	285	220	220	285	220
1/2	235	305	235	235	305	235
19/32	290	375	290	290	375	290
5/8	310	405	310	310	405	310
23/32	350	455	350	350	455	350
3/4	360	470	360	360	470	360
7/8	425	555	425	425	555	425
1	470	610	470	470	610	470
1-1/8	525	685	525	525	685	525
Structural I Multiplier						
	1.3	1.0	1.3	1.4	1.0	1.4

(a) See Table 4C for multipliers for other species Groups.

Note: This version is superseded by a more current edition. Check the current edition for updated design and application recommendations.

TABLE 4B (Continued)

SANDED GROUP 1^(a) PLYWOOD DESIGN CAPACITIES

Nom. Thick	Stress Parallel to Strength Axis			Stress Perpendicular to Strength Axis		
	A-A, A-C	Marine	Other	A-A, A-C	Marine	Other
PANEL RIGIDITY THROUGH THE THICKNESS G_{v,t_v} (lb/in. of panel depth)						
1/4	24,000	31,000	24,000	24,000	31,000	24,000
1 1/32	25,500	33,000	25,500	25,500	33,000	25,500
3/8	26,000	34,000	26,000	26,000	34,000	26,000
15/32	38,000	49,500	38,000	38,000	49,500	38,000
1/2	38,500	50,000	38,500	38,500	50,000	38,500
19/32	49,000	63,500	49,000	49,000	63,500	49,000
5/8	49,500	64,500	49,500	49,500	64,500	49,500
23/32	50,500	65,500	50,500	50,500	65,500	50,500
3/4	51,000	66,500	51,000	51,000	66,500	51,000
7/8	52,500	68,500	52,500	52,500	68,500	52,500
1	73,500	95,500	73,500	73,500	95,500	73,500
1-1/8	75,000	97,500	75,000	75,000	97,500	75,000
Structural I Multiplier						
	1.3	1.0	1.3	1.3	1.0	1.3
PANEL SHEAR THROUGH THE THICKNESS, F_{v,t_v} (lb/in. of shear-resisting panel length)						
1/4	51	66	51	51	66	51
1 1/32	54	70	54	54	70	54
3/8	55	72	55	55	72	55
15/32	80	105	80	80	105	80
1/2	81	105	81	81	105	81
19/32	105	135	105	105	135	105
5/8	105	135	105	105	135	105
23/32	105	135	105	105	135	105
3/4	110	145	110	110	145	110
7/8	110	145	110	110	145	110
1	155	200	155	155	200	155
1-1/8	160	210	160	160	210	160
Structural I Multiplier						
	1.3	1.0	1.3	1.3	1.0	1.3

(a) See Table 4C for multipliers for other species Groups.

4.5.3. Elevated temperature

Capacities in Tables 4A and 4B apply at temperatures of 70° F [21° C] and lower. Wood structural panel parts of buildings should not be exposed to temperatures above 200° F [93° C] for more than very brief periods. However, between 70° F [21° C] and 200° F [93° C] adjustments to capacity generally do not need to be made, because the need for adjustment of dry capacities depends upon whether moisture content will remain in the 12 to 15% range or whether the panel will dry to lower moisture contents as a result of

the increase in temperature. If drying occurs, as is usually the case, the increase in strength due to drying can offset the loss in strength due to elevated temperature. For instance, temperatures of up to 150° F [66° C] or higher do occur under roof coverings of buildings on hot days, but they are accompanied by moisture content reductions which offset the strength loss so that high temperatures are not considered in the design of roof structures. To maintain a moisture content of 12% at 150° F [66° C], sustained relative humidity of around 80% would be

required. The designer needs to exercise judgment in determining whether high temperature and moisture content occur simultaneously, and the corresponding need for temperature adjustment of capacities.

4.5.4. Pressure treatment**Preservative treatment**

Capacities given in this document apply, without adjustment, to plywood pressure-impregnated with preservative chemicals and redried in accordance with American Wood Preservers Association (AWPA) Standard C-9¹⁰.

Note: This version is superseded by a more current edition. Check the current edition for updated design and application recommendations.

Appendix C: Construction and Deconstruction Manual

Kit of Parts

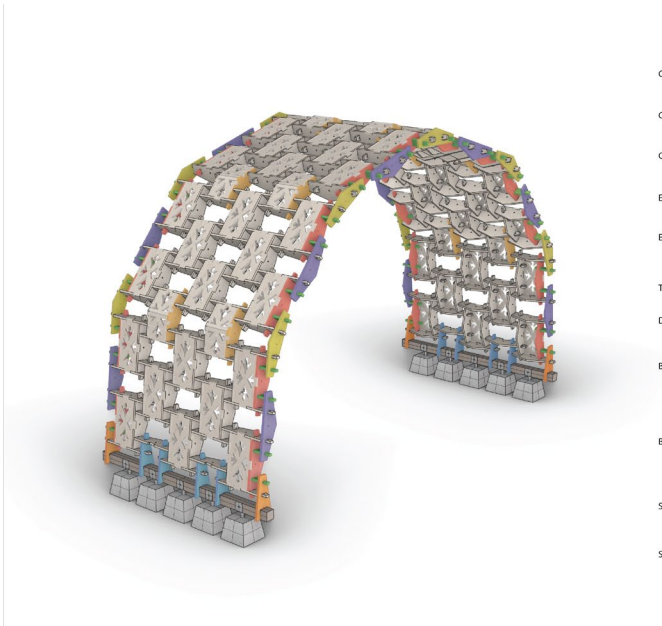

C1		x192
C2		x24
C3		x20
E1		x12
E2		x10
T1		x48
D1		x96
B1		x8
B2		x4
SP1		x48
SP2		x24

Frame Pieces:

Piece 1: C1

Piece 2: C2

Piece 3: E1

Piece 4: T1

Piece 5: D1

Piece 6: C3

Piece 7: E2

Piece 8: B2

Piece 9: B1

Piece 10: SP1

Piece 11: SP2

Base Piece Module (M1)

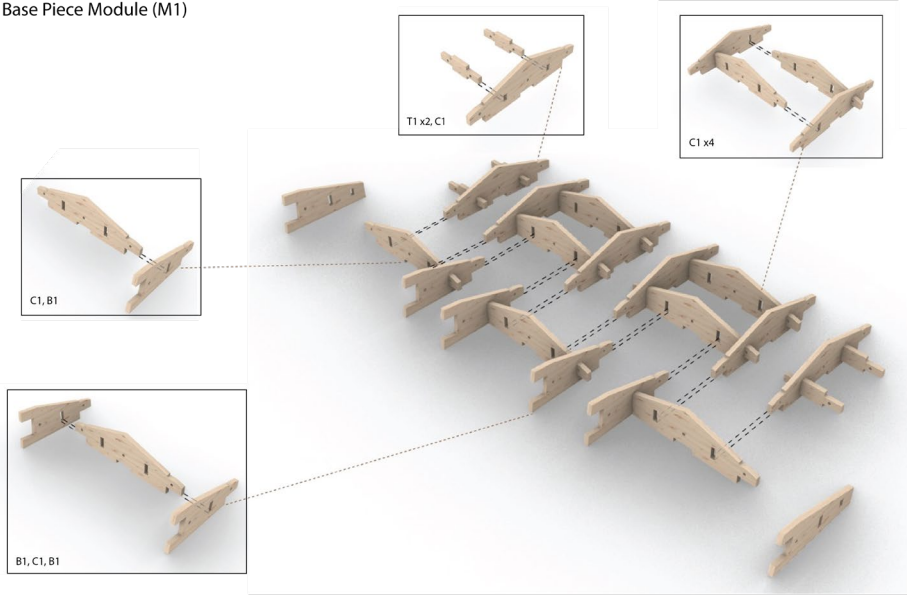

Typical Piece Module (M2)

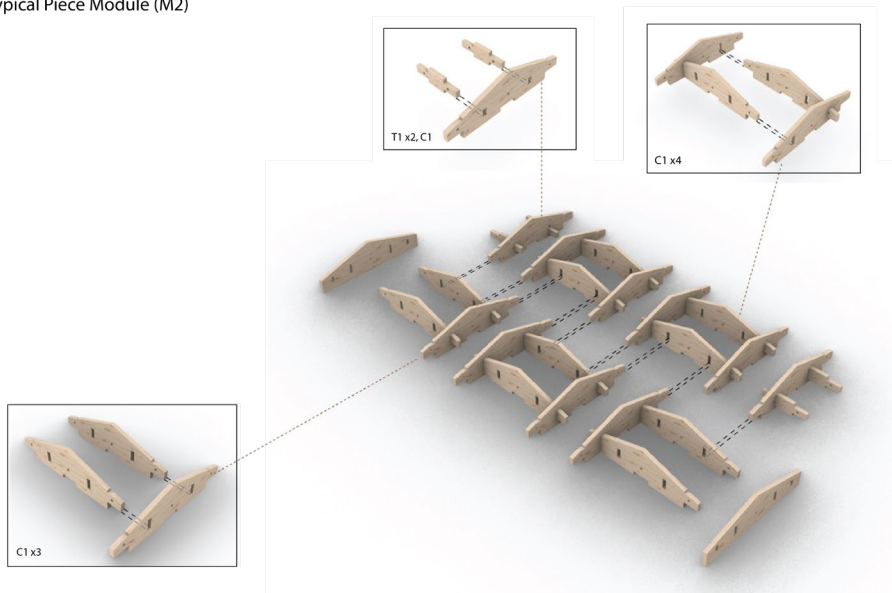

Modified Typical Piece Module (MM2)

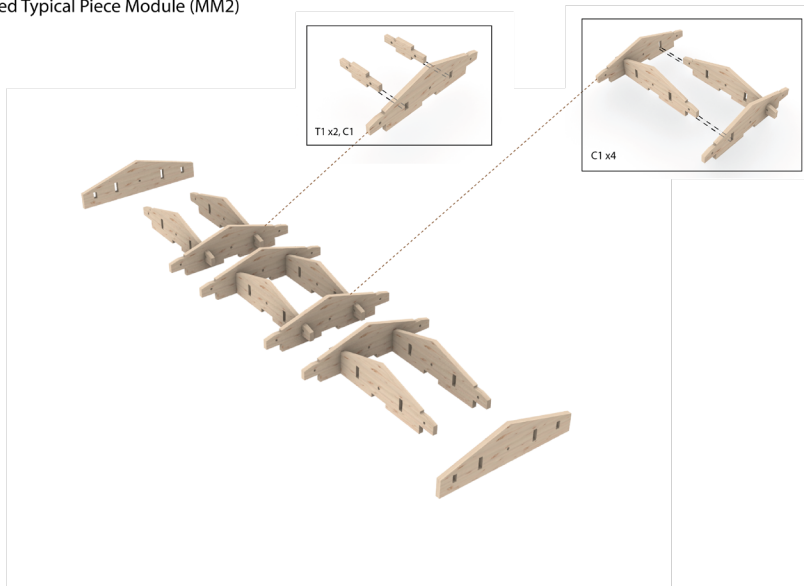

Angled Piece Module (M3)

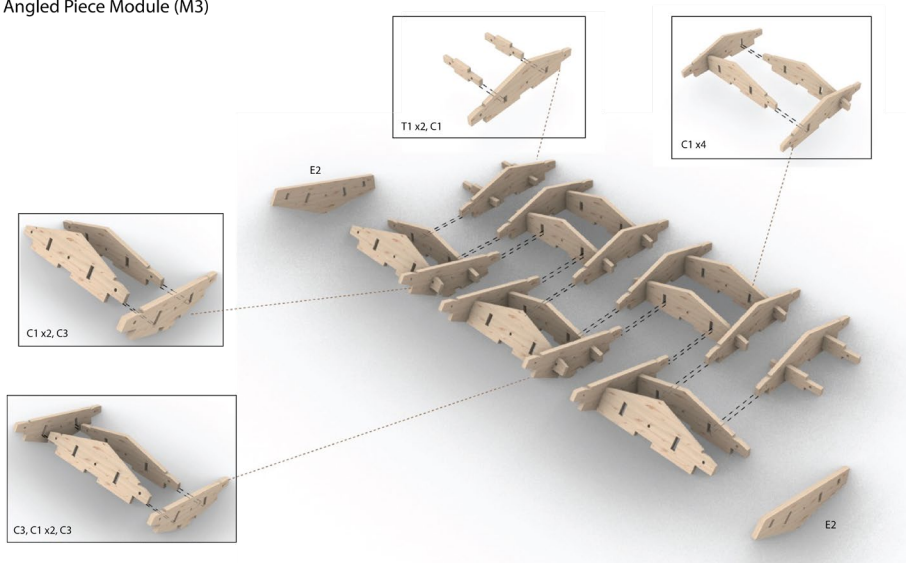

Wall Assembly (M1+M2+M3)

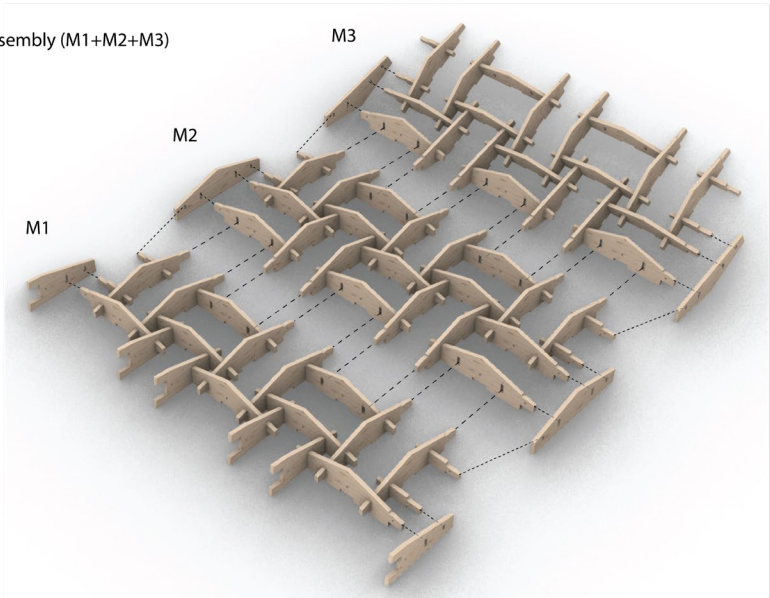

Upper Arch Assembly (M2+M3)

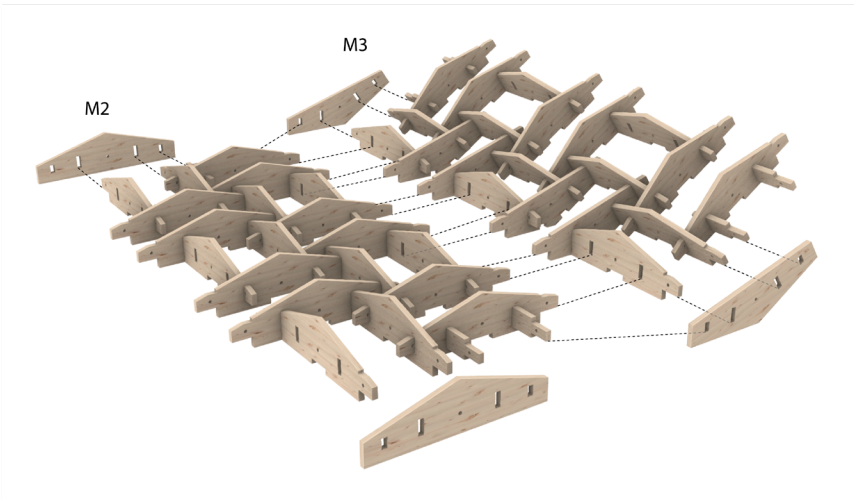

Keystone Assembly (M2+M3+MM2)

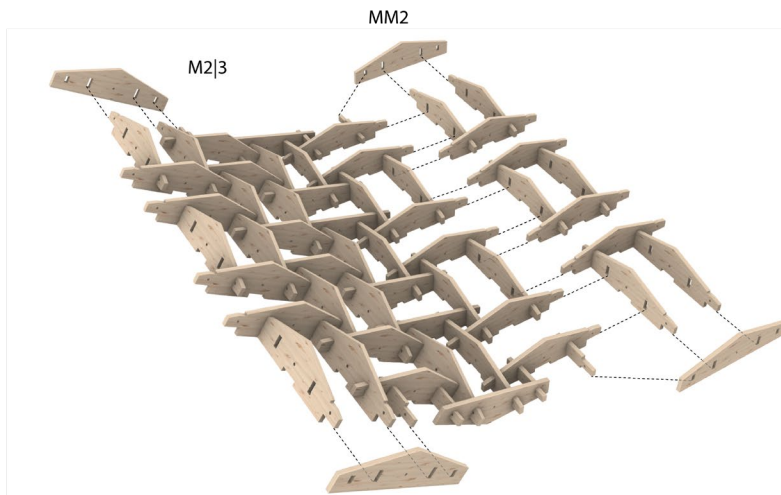

M1 (Base Module) = C1, C2, B1, B2, T1

M2 (Regular Module) = C1, C2, T1

M3 (Angle Module) = C1, C2, C3, T1

M4 (Keystone Module) = C1, C2, C3, E2, T1

M1 to M2, need E1

M2 to M3, need E2

M3 to M2, need E1

M2 to M4, need E1

Construction

Construction of modules

Assembly/shoring of frame from modules (m1 on ground, m2 with struts, stiffen,)

De-shoring

Step 1

4x4 Pressure Treated Lumber



Concrete Footing

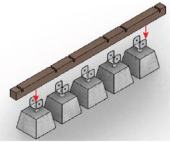
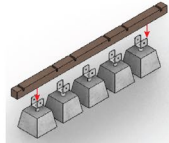

Step 2

M1

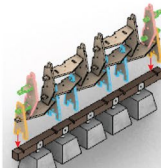
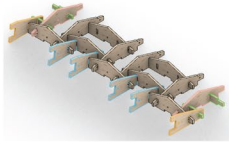

Step 1

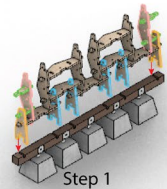

Step 1

Step 3

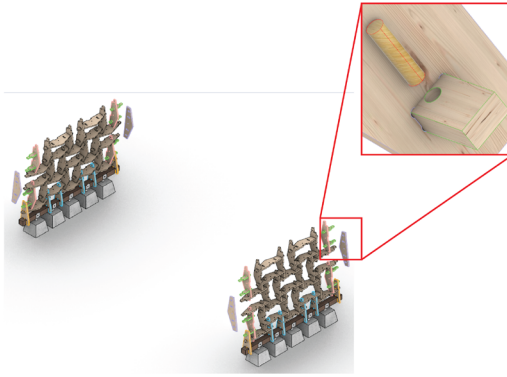
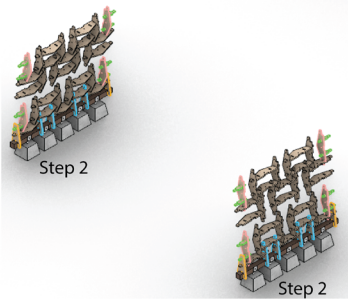
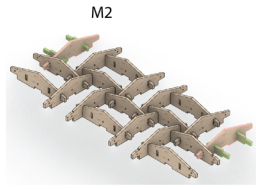

Step 5

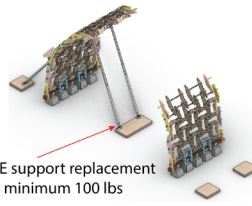
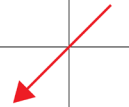
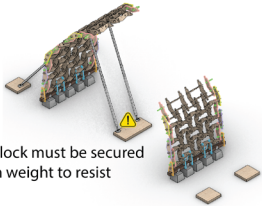
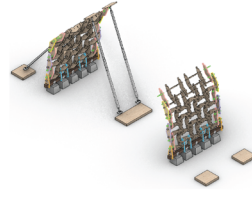
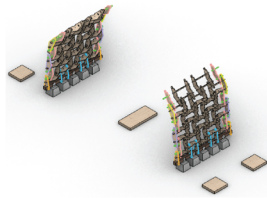
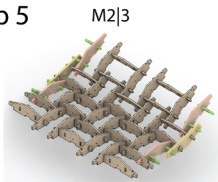

Step 6

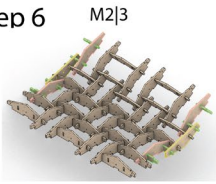

M2|3



E1

GIRAFFE GIR 3000



GIRAFFE GIR 4000

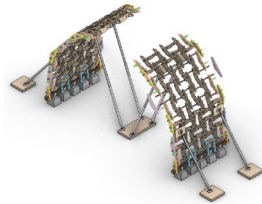
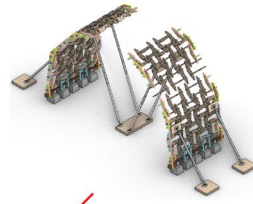
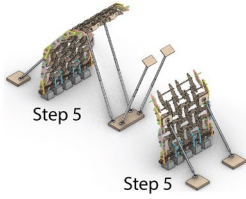

Step 7

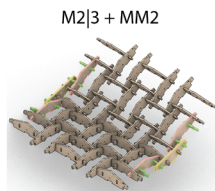

M2|3 + MM2



E1

Handcrank Forklift

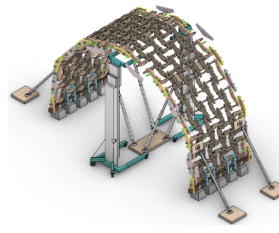
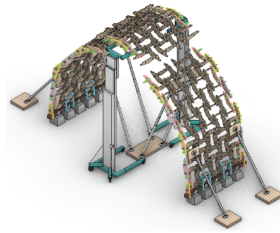
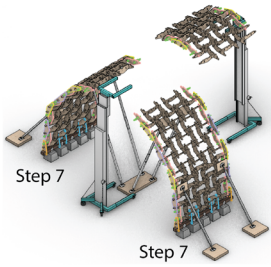

Step 8

SP1



SP2

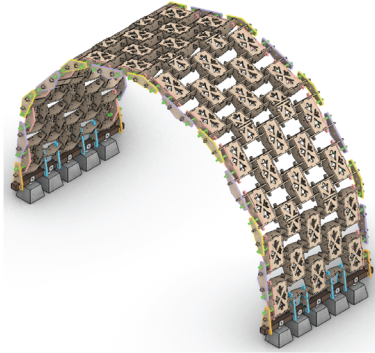
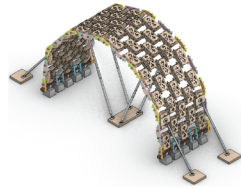
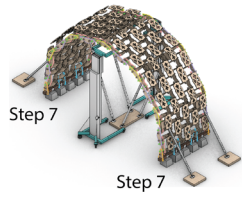

Deconstruction

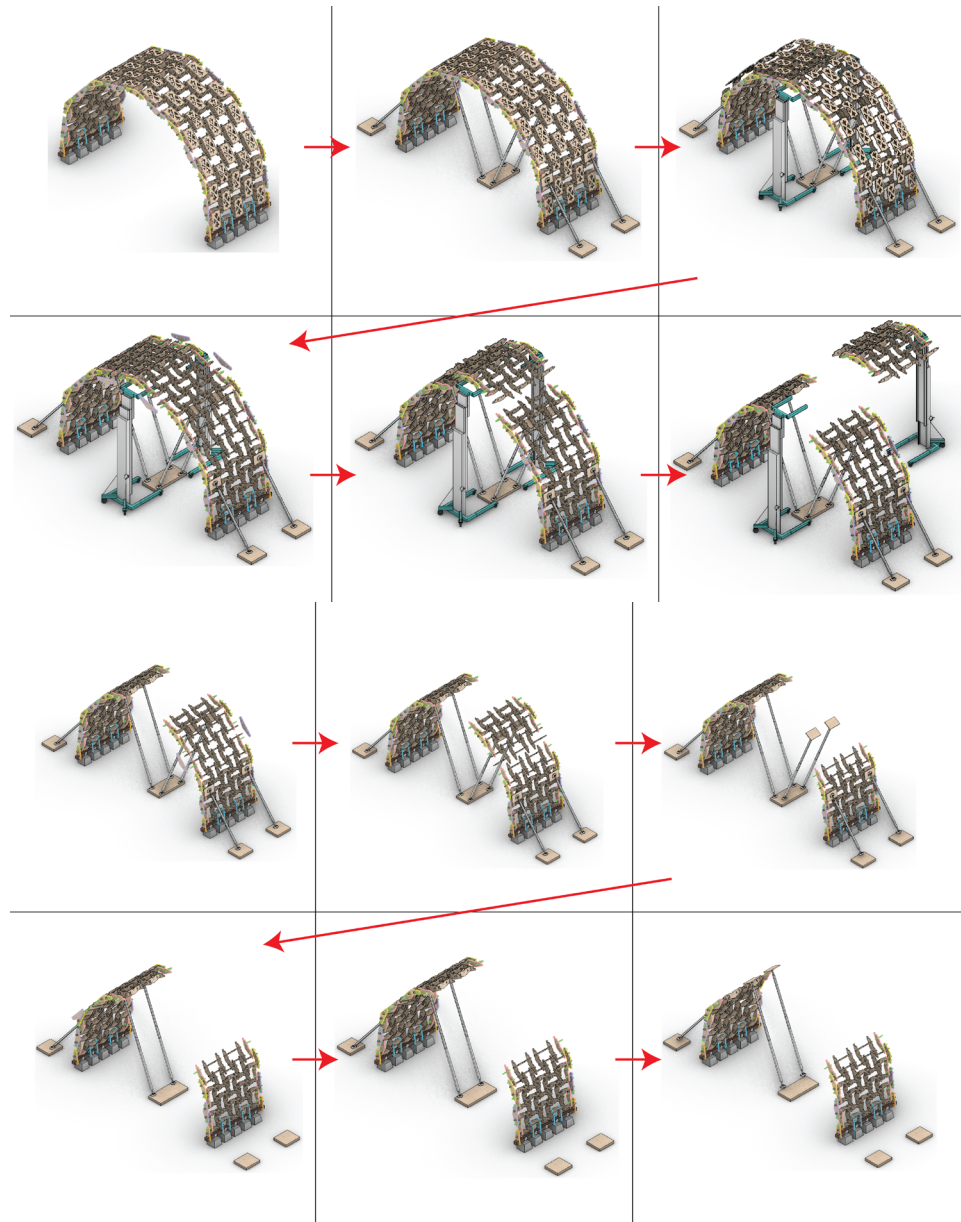

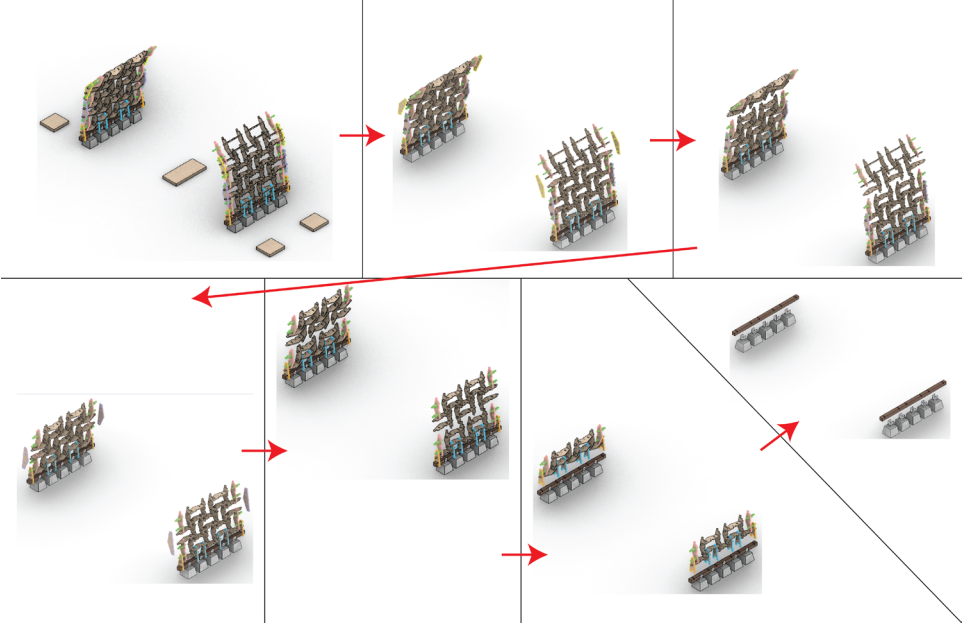

SCI Directors and Staff

Marc Schlossberg	SCI Co-Director, and Professor of Planning, Public Policy and Management, University of Oregon
Nico Larco	SCI Co-Director, and Professor of Architecture, University of Oregon
Megan Banks	SCYP Director, University of Oregon
Lindsey Hayward	SCYP Assistant Program Manager, University of Oregon
Zoe Taylor	Report Coordinator
Ian Dahl	Graphic Designers
Danielle Lewis	