

City of Milton Freewater

Special Transportation Area Plan and Transportation System Plan Update

Submitted to:
City of Milton-Freewater
ODOT

Prepared by:
Otak, Inc.
17355 SW Boones Ferry Road
Lake Oswego, Oregon 97035
Otak Project No. 12679

Kittelson & Associates, Inc.
610 SW Alder, Suite 700
Portland, OR 97205

June 30, 2005

Acknowledgements

This project is partially funded by a grant from the Transportation and Growth Management (TGM) Program, a joint program of the Oregon Department of Transportation and the Oregon Department of Land Conservation and Development. This TGM grant is financed, in part, by federal Transportation Equity Act for the 21st Century (TEA-21), local government, and the State of Oregon funds.

The contents of this document do not necessarily reflect views or policies of the State of Oregon.

Table of Contents

Summary Report
Plan and Supporting Graphics

Appendix

Adopted Ordinance
Kittelson and Associates Technical Memorandum
Funding Memorandum
Recommended Planting List
Redevelopment Options Memorandum
SHPO Memorandum
Economic and Existing Code Memorandum

Introduction

The intent of this project is to provide a STA Plan and TSP Update in cooperation with local businesses that maintains the through movement on Highway 11, while also making downtown more accessible and safe for local citizens. Planning was conducted for pedestrian and bicycle improvements to reduce local traffic on the highway and enhance local opportunities for walking and biking. In addition, development of zoning and development code amendments has been coordinated for consistency with the TSP to assure the transportation system is adequate to serve the future transportation needs.

This project evaluated effective development of compact commercial centers that are pedestrian-friendly, mixed-use, and balance local/through traffic needs. Ordinance revisions have been written to compliment the STA Plan and TSP Update, including a new downtown zone description.

The focus of this project is to guide the management of existing transportation facilities in the downtown and the design and implementation of future facilities for the next 20 years. This report identifies specific right of way improvements and prioritizes transportation projects for inclusion in the City's Capital Improvement Program.

Existing Conditions

The City has a population of 6,560 and is located on State Highway 11. The City is located 8 miles south of the Oregon/Washington border. The City has two established downtowns, reflecting the historical towns of Milton and Freewater. Milton is on the south side of the City and Freewater to the north. Outside downtown, commercial development extends along the Highway 11 corridor. The City's TSP was completed and adopted in 1999.

The area has had recent and growth and is projected for more. It is important to address access, circulation, and traffic problems now before they get even more difficult, and potentially expensive to solve. Main Street is currently four lanes, two lanes in each direction, with no center turn lane. There are no traffic signals or stop signs on Main Street within the study area.

Summary of Process

A Management Team was established to serve as the technical liaison to help guide the project and provide direction on technical and policy issues. A Technical Advisory Committee was also established to review work projects and at the conclusion of the project, make a recommendation.

This project started with a stakeholders' walking tour of the downtown "Main Street" commercial area to assess community needs and interests, identify local changes that have occurred to the downtown commercial area since the TSP was written, and identify alternatives for the STA Plan and TSP Update. Feedback was received from the stakeholders as to what their vision for Downtown Milton-Freewater included.

The design team then analyzed plans, policies, and data related to the commercial area conditions to identify project issues and opportunities. Items researched included the capacity of streets, sidewalks, parking and other spaces and how each of these is currently being used. Bike/pedestrian mobility, safety and access in relationship to neighborhoods, historic features, schools, recreation/parks, library, and other potential activity centers were also evaluated.

Underutilized and vacant parcel redevelopment opportunities on Main Street were also identified, including downtown alleyways and side streets. Existing and potential land use (planning and urban design) concerns, environmental issues, and conflicts with other modes were also identified as part of this study.

A Youth workshop was conducted to gather input from high school-aged youth on how they would like to see downtown develop. They were an engaging group that provided thoughtful and insightful ideas for improving downtown, both aesthetically and through land use improvements.

The public was then invited to Open House #1, where a presentation was given on walkable communities, focusing on street design, pedestrian crossings, and bike facilities. The presentation also included economic and community-building reasons to design for walkability. The workshop provided images of plaza/pocket parks, public art and other streetscape possibilities to help people communicate what their vision for downtown was.

After the Open House, redevelopment options were prepared illustrating various ways to develop Main Street based on the feedback received at the first public open house. These options included potential street, pedestrian and bicycle access design configurations, including circulation and crossing needs to downtown; different hardscape and landscape improvements; streetscape elements including street trees, bicycle racks, benches, illumination; and buffering/screening options.

A second Open House was conducted to present redevelopment options for downtown. A discussion was held at the Open House regarding land uses, types, densities, styles, analysis of costs, traffic operations, impact to codes and policies, and public infrastructure.

After the Preferred Redevelopment Option was established, existing and potential land use (planning design) concerns were then discussed in further detail. The code was then updated to reflect the changes necessary to support the plan.

The plan, as well as zoning and development code updates, was presented to the Planning Commission and City Council in Work Sessions for discussion and feedback. The proposed STA Plan and TSP Update, along with the code amendments, was then presented and adopted at a Joint Planning Commission/City Council Hearing.

Preferred Redevelopment Option

The Preferred Redevelopment Option combines converting Main Street to a three-lane facility through the Downtown District while keeping the remaining corridor four lanes and improving it with traffic calming features.

Traffic Signals

The City will need a strong advocate to get a pedestrian activated crossing signal placed in the Main Street corridor. ODOT may or may not approve a pedestrian activated crossing signal due to traffic volumes that currently do not reach the threshold for requiring one.

A full traffic signal will be hard to justify to ODOT. The community would likely need to close side streets to drive up traffic volumes enough to warrant a signal. For example, if a signal was placed at the intersection of 9th and Main, 8th and 10th streets would need to be closed. Initially it seems unlikely that ODOT would approve a full signal based on existing traffic volumes.

If the City decides to pay for and install an un-warranted traffic or crossing signal, it is possible they would be required to be responsible for any liabilities (i.e. a pedestrian gets hit in the crosswalk) that may occur.

As part of this project, a full report discussing traffic operations and analysis in detail has been prepared by Kittelson & Associates, Inc. and has been included in the appendix of this report.

Parking

It is essential to provide on-street parking in front of businesses in the Downtown and Civic Districts. The higher density of commercial establishments in the area contributes to the high parking demand. For most downtowns, the parking demand is highest during the mid-day period or just after lunchtime in the early afternoon. Public off-street

parking is available in the study area and is provided in four off-street parking lots in the corridor. These four lots provide approximately 130 parking spots for public use.

In addition, several private retail/commercial businesses in the study area have dedicated parking spaces for customers and employees. The majority of these lots are found at the north end of the corridor and supply approximately 180 business off-street parking spaces. In the future, if parking demand increases dramatically, it is possible that the private business parking spaces could be integrated into the public supply as part of an overall parking management plan for downtown.

As part of their analysis, Kittelson & Associates, Inc. included a Parking Inventory and Utilization Map (Figure 5) as part of their report.

Access

According to the 1999 OHP, if a section of statewide highway is designated as Special Transportation Area (STA), as planned for ORE 11 through Milton-Freewater, "direct street connections and shared on-street parking are encouraged" and "local auto, pedestrian, bicycle, and transit movement to the area are generally given more importance than the through movement of traffic." In case of public roadway spacing, the existing city block or the city block spacing as identified in the local comprehensive plan is an accepted norm. For private driveways, minimum driveway spacing of 175 feet, measured from center to center on the same side of the roadway is allowed.

A majority of the existing accesses do not meet the ODOT access spacing standard for an STA. Nonetheless, due to the low traffic volume in the area, and historically low number of crashes, the existing accesses are anticipated to operate safely and acceptably. Any future development in the corridor should be encouraged to meet the spacing standard and ensure that proposed driveways operate safely.

Safety and Traffic Issues

Traffic Speed – The speed at which vehicles, including large trucks, traveled through downtown was a primary concern during the planning process. Currently, vehicles travel above the speed limit through the corridor, partly because it "feels" faster due to the width of the right-of-way. Traffic calming measures have been introduced to "narrow" the visual distance between the curbs, including street trees, bump outs and a median. Introducing these traffic calming design elements will result in lowered speeds as people are become more aware of their surroundings.

Pedestrian Crossings – Pedestrians crossing a busy street without a signal for assistance was another primary concern voiced by citizens. The traffic calming design elements

discussed above will help reduce the speed of traffic. That, combined with well marked and enhanced crosswalks, will help pedestrians feel safer by making cars more aware of them. Bump outs and medians will also give pedestrians a safe refuge while waiting for a break in traffic.

Large Vehicle Access To Businesses In Downtown – Truck circulation to/from and within Downtown will be a consideration as detailed design begins. Considerations will include turning radii to and from businesses on ORE 11 and turning radii at intersections within the STA. The ODOT Highway Design Manual provides guidance on the standards for these features. The goal of the STA is to develop main street type access in downtown. This includes limiting the number of direct driveways onto and off-of ORE 11 and designing low speed turns at intersections. The design will not preclude large vehicles circulating within downtown. At corners, large vehicles may have to travel into the opposing lane on the minor street to complete the turn, or special design exceptions can be achieved with ODOT. Large vehicle direct access onto individual properties will become more constrained as downtown redevelops with STA compatible land uses; however designs can be developed to maintain access to specific properties.

Travel Lane Widths – Under the proposed plan, there is ample space within the current right-of-way to maintain 12-foot travel lanes within the STA. A 12-foot travel lane is consistent with ORE 11 lane widths outside the STA. Therefore large vehicles accommodated on ORE 11 outside of Downtown will also be accommodated through Downtown. In the event that overload or oversize vehicles are traveling through Milton-Freewater standard ODOT requirements would have to be fulfilled.

Loading Zones – Loading zones within the STA will also be identified as part of the detailed design. The location and number of the loading zones will be dependent on the distribution of businesses, and parking demand. The loading zone spaces can be permanent loading zone spaces, or they can be regular parking spaces during peak parking periods, and loading zone spaces during off-periods. As Downtown becomes more popular, it may be necessary to limit loading to specific off-peak hours (e.g. early in the morning).

Bicycle Facilities

There are currently no striped bicycle lanes through the study area. At the first Public Open House residents voiced strongly that they did not think it was appropriate to have striped bike lanes on Main Street. However, there are a few people in support of having bike lanes, striped or un-striped, as part of Main Street.

The existing Right-Of-Way does not have enough room to accommodate the existing four lanes of traffic, parking on both sides of the street and a striped bike lane the entire length of the corridor. Residents were unwilling to give up parking in order to provide bicycle lanes.

The proposed three lane configuration has enough room to accommodate travel lanes, parking on both sides of the street and marked bicycle lanes. However, residents again voiced at the first Public Open House that they did not want bike lanes on Main Street. In all cases they would prefer that bike routes be designated on parallel streets to Main Street, such as Columbia Street and Mill Street.

At the second Open House citizens again voted against incorporating striped bike lanes on Main Street. In addition to safety concerns due to possible conflicts with large trucks, the preferred option incorporates four lanes of traffic which does not allow enough room to also have bike lanes.

However, due to funding sources that may be tied to providing bicycle facilities, it was decided to allow bike facilities on the three lane configuration with alternate bike routes along Mill and Columbia (parallel to Main St.) along the four lane section.

Transit

Milton-Freewater recently started bus service again that provides local connection throughout Milton-Freewater as well as connections to Walla Walla. Proposed improvements should accommodate bus facilities and plan for future expansion of the transit system

Potential Development Projects

The Opera House has great potential for becoming a landmark for the downtown area of Milton-Freewater. There are several other buildings listed on the Historic Register in the area and a historic "focus" could be developed as a point of interest for visitors. The historic focus could help draw tourism spending which would in turn support commercial as well as arts, entertainment and recreation and accommodations and food service. The City should develop programs to assist owners and operators of these shops to upgrade their facilities through coordinated efforts which are sensitive to the historic and architectural values.

Streetscape improvements will need to be coordinated with State Historic Preservation Office prior to and during the engineering phase of the projects. Improvements, depending on the nature of the changes, which do not fit with the historical character or history of Milton-Freewater may impact decisions to be able to create a Historic District in the future. Proposed changes should be as unobtrusive as possible. Additional

information regarding SHPO coordination, including contact information, has been included in the appendix section of this report.

During the second Open House citizens responded favorably to allowing the residential areas in the Gateway Zones adjacent to Main Street to operate home-based businesses. In order for the downtown area to draw more business, flexibility should be given to the corridor to allow businesses to develop while still retaining the unique residential setting.

In addition, lots for potential redevelopment have been identified. Some of the lots are vacant and are ready for redevelopment while other lots are more appropriate for future redevelopment opportunities after their current land use changes.

Downtown District for Freewater

It is recommended that Freewater adopts a similar ordinance to Milton, addressing similar issues while making them specific to their area. Coordination between the two areas, especially due to their close proximity to each other, is encouraged. The local comprehensive plan recognizes the importance of redeveloping the two downtowns. The plan states that "a pressing commercial need is for redevelopment and upgrading of the two old downtowns. Major revitalization has taken place in the south and north districts. These efforts have helped to bring new businesses and shoppers to the areas. It is vital that other store owners and operators continue the trend started by these projects so that everyone can benefit from increased shopping activity in the community. The city has provided technical help to shopkeepers and the Chamber of Commerce to initiate and assist these efforts. This will remain a high priority."

Redevelopment of Alleyways

Currently, the alleyways in the project area are in various stages of improvement. Some of the alleyways are unimproved while others are paved. The City has a standard alleyway cross section and it is encouraged that as lots adjacent to alleys develop or re-develop the alleyways are brought up to City standards where possible.

For this study, the focus was placed on re-vitalizing Main Street to become a more vibrant and integral part of town. As improvements happen over time, it will be appropriate to look at how the alleyways can play a more integral role. As re-development occurs on Main Street it will affect the use of the alleyways. Some alleyways may be appropriately developed to accommodate vehicle circulation and access while others may be better suited for pedestrian connections. However, until the new use is determined it is difficult to make specific recommendations for the alleyways. It is strongly recommended that the focus remain on Main Street until such a time that it's appropriate to dedicate resources to the alleyways.

Currently the alleyways are utilitarian in nature and primarily serve vehicle access. They serve a secondary circulation system and could potentially be further developed to accommodate loading and unloading activities in certain blocks for businesses on Main Street, which would free up parking in front of the buildings. In the future, some of the alleyways could also provide pedestrian connections if they don't conflict with vehicle circulation.

However, it is also important for encouraging redevelopment opportunities that the City accommodate alley access to landlocked parcels where possible. This may help spur redevelopment opportunities where access issues had previously been a concern.

Creation of Greenspace and Pocket Parks

The creation of public spaces through pocket parks and greenways is encouraged as a way to enhance the downtown area and promote pedestrian activity. Potential "greenspace" areas have been identified on the plan. In addition, "pockets" of greenspace should be encouraged as new development moves in or existing buildings are replaced, as small spaces for tables and benches will help enhance the downtown core. In addition, greenspace can be used to encourage pedestrian links between main street and adjacent streets and alleys.

Impact to Codes and Policies

Three new zoning districts were created to assist in creating a pedestrian-oriented, mixed use downtown that preserves and enhances the historic buildings and existing residences. The development and design standards contained in the Downtown Business (DB), Main Street Residential (MSR), and Civic Overlay (CO) districts zoning are intended to assist with the revitalization of the downtown area. Buildings, streets and public spaces are required to be oriented toward the pedestrian, while not excluding the automobile, to support mixed use developments and provide a pedestrian-friendly character of the area. South and North Main Streets shall be the business and mixed-use centers of the community. South Main serves the additional role of being the civic center of the community.

The Main Street Residential (MSR) district is intended to preserve the residential feel of the district while allowing small-scale businesses that are compatible with the existing residential uses. The Main Street Residential (MSR) district shall support a mix of residential and small scale business. Land uses within the Main Street Residential (MSR) district shall be compatible in size and design with the residential character of the area. Small-scale businesses in the MSR district should be encouraged to locate in former residences.

The Downtown Business (DB) district is the place for people to gather and promote commercial activity. Improved pedestrian access and streetscape through the downtown will improve the district's image. Elements of design and appropriate mixed use development will enhance this goal. Mixed use developments should be permitted and encouraged in the Downtown Business (DB) District.

The Civic Overlay (CO) district contains special uses to emphasize the City's desire to concentrate civic facilities in the heart of the downtown. This section lists those uses allowable in the Civic Overlay (CO) district. The development standards in the Downtown Business (DB) district shall apply to all development in the Civic Overlay (CO) district.

Adopted ordinances, as well as a map showing zoning code changes, are included in the appendix of this report.

Economic Analysis

Currently, the Milton-Freewater economy revolves primarily around the regional agricultural-base which includes productive orchards, irrigated row crops and dry land wheat, pea and bean production. Related spin-off industries include food handling, processing, packaging, and shipping. Milton-Freewater's access to Interstate Highway 84, US Route 395, rail and water terminals enables regional agricultural goods to be efficiently shipped nationally, and exported to many countries around the world.

For downtown Milton-Freewater, the most favorable retail growth potential appears to be within the miscellaneous retail, and food and beverages categories. However, some general merchandise will also be supported by increased retail sales. The other/miscellaneous category could possibly include a modest-sized lodging facility and/or an additional independent bed-and-breakfast, which could potentially be added to support regional visitation trends.

Tourism and visitation spending plays an important role in supporting commercial development in Umatilla County and is accredited for supporting 1,720 jobs. The fastest growing segments that were supported by tourism spending over the 1991-2003 time period included "arts, entertainment and recreation" and "accommodations and food service".

The demand for office space in downtown Milton Freewater depends on growth in employment in the competitive market region and changes in household formations and work location preferences. As households get older, demand for professional services, such as medical, legal and financial services tends to rise. Other factors, such as availability and price of land/buildings, telecommunications and internet access also play into location decisions.

In the short-term (years 1-5), this commercial demand in downtown Milton Freewater could likely be accommodated in existing vacant or underutilized downtown buildings. In the longer-term, it is likely that some of the commercial office growth would require new buildings on vacant or redevelopment parcels.

The future outlook for office job growth and land needs are forecasted to show an improvement over the next 10 years. Steady growth in county wide tourism spending as well as moderate growth in local buying power holds promising potential for existing and new commercial, retail and lodging establishments.

A full Economic Analysis has been included in the appendix of this report.

Funding Information

As part of the funding information for this report, research was done for the following site furnishings: benches, litter receptacles, bike racks and drinking fountains. Product manufactures, contact information, and prices (not including installation) have been included in the Funding Memorandum included in the appendix of this report. The City currently has light fixtures and tree grates that have been used on previous projects. For a sense of continuity throughout the corridor it is recommended that the same product models and manufacturer are used on future improvements.

The City currently has an Urban Renewal District and has successfully provided programs in the past to assist business owners with making improvements. The mission of the Milton-Freewater Urban Renewal Agency is to eliminate blight and depreciating property values in the Area and in the process, attract private investments that will improve property values, create jobs well matched to the labor force and create opportunities for business expansion and development.

Two primary goals that have remained consistent throughout the life span of the URA are the elimination of blight and the creation of jobs. Money to help accomplish these goals is created through this agency via tax increment financing. The Milton-Freewater Urban Renewal will continue to be a very positive and viable tool in revitalizing the community.

The city also previously used a business improvement grant program that ran for three years, with up to \$2000 being reimbursed to the property owner for storefront improvements. The program worked with 75% being paid by the Urban Renewal Agency and 25% being paid by the property owner.

This program was recently revised to focus on the new frog branding effort recently started by the City. The program has now created a frog art reimbursement program for business owners paying \$125 for a carved wooden statue with a value of \$500.

The City should consider the following options to enhance or modify the existing downtown urban renewal district:

1. Re-establish the store front improvement program and consider making it available for residential frontage improvements - The vision for South Main Street and implementing zoning describe a pedestrian-friendly, economically vital, and nicely landscaped streetscape and front yard area along South Main. Providing financial assistance to achieve these objectives will help both investors and city interests move toward the vision. The plan and implementing zoning apply to both Downtown Business properties (that have storefronts) and Main Street Residential properties that have a residential character but may have small businesses in them. Extending frontage improvement incentives to the residential properties will help tie the entire area together with an improved look that is consistent with the plan.

2. Ensure the "life" of the district is consistent with the timing for public improvements - Many other Oregon communities that have improved their Main Streets have seen private investment that follows. One improvement leverages the other. Milton Freewater should make sure the downtown Urban Renewal district is active during and beyond the period where the streetscape improvements are finished, so that the City can capture the increment from the private investment that may follow.

3. Ensure that key "catalyst" properties are fully within the district boundaries - The current boundaries should be reviewed to ensure that the most likely redevelopment sites (consistent with the new zoning) are fully within the renewal district boundaries.

Another option to consider is working with the State Economic and Community Development Department and ODOT to form a Community Solutions Team to focus on ways to improve downtown Milton. In other areas of the state the Community Solutions Team has been successful in implementing infrastructure improvements to further community redevelopment. For more information, Mike Burton, Manager of the State Economic and Community Development Department, can be reached at 503-986-0129.

The Funding Memorandum included in the appendix describes in detail several programs available to help fund future improvements.

Project Prioritization and Descriptions

The improvements to Main Street have been broken out into three projects and prioritized as high, medium, and low importance projects. Identifying separate phases and breaking the project out into manageable pieces will allow the City to start making improvements, plan for future and identify funding sources. Descriptions of the projects are provided in the following paragraphs.

The high priority project is the South Gateway between SE 14th and SE 12th. This project was chosen as a high priority because it is easy to break out, relatively inexpensive to construct, and will help make a visual impact and generate excitement that more improvements will be made. This project creates a gateway element to announce the edge of the downtown area and to help reduce vehicle speeds. The intersection of SE 14th will need additional engineering and design work to determine how best to accommodate turning movement onto and off of Main Street. The intersection will likely include a landscape median that could be tied in visually with the adjacent park.

Improvements throughout the two blocks also include sidewalk improvements, street trees in planter strips, and bulb outs at the intersection of SE 12th. On street parking will remain along the two blocks. The designs of these proposed improvements, as well as future phases, are shown on drawings included in this report.

A transition median starting at SE 12th is also shown in the high priority project area, but would not be constructed until the second phase. The transition median facilitates the transition from four travel lanes down to two travel lanes and a median, which will not happen until the next phase.

The medium priority project is the Downtown District between SE 12th and SE 8th. This project is the "heart" of the corridor and will have a large impact on improving the visual aspect of the street, creating more pedestrian friendly spaces, and providing traffic calming effects.

Improvements throughout the four blocks change the lane configurations from four lanes down to two with a center median and turn lane. On street parking is provided as well as marked bike lanes in both directions. Bulb outs are provided at each intersection as well as sidewalk improvements, street trees in tree grates, and crosswalk improvements.

The transition medians, one at SE 12th and the other at SE 8th, will also need to be constructed during this phase. The transition medians will facilitate the transition from four travel lanes into two travel lanes and a median. These medians are not intended to be landscaped but will use striping to designate their boundaries.

The center medians are to be planted with street trees, low shrubs and groundcover. A listing of recommended plants for the corridor has been included in the appendix of this report. Prior to installation, the medians will need to be further coordinated with the community and businesses.

The low priority project is the Civic District and Main Street Residential area between SE 8th and SE 3rd. This area can be expanded from the Downtown District on a "block by block" basis as redevelopment occurs and/or funding becomes available.

Improvements throughout this area include sidewalk improvements, street trees in planter strips, and bulb outs at the intersections. On street parking will remain along the corridor as well. As part of this planning study, the community expressed concern of the intersection of Main Street and 3rd and would like this area to be further studied during the engineering phase.

The three projects have been further broken down in the next section, including a preliminary cost estimates for the improvements.

Cost Estimates (Capital Improvements Plan)

Cost estimates have been included for the improvement area. The estimates have been broken out into three projects and identified as high, medium, and low priority. The high priority project is the South Gateway between SE 14th and SE 12th, the medium priority project is the Downtown District between SE 12th and SE 8th, and the low priority project is the Civic District and Main Street Residential area between SE 8th and SE 3rd. These projects and cost estimates are updated to be included in the City's Capital Improvement Plan.

MAIN STREET PLAN

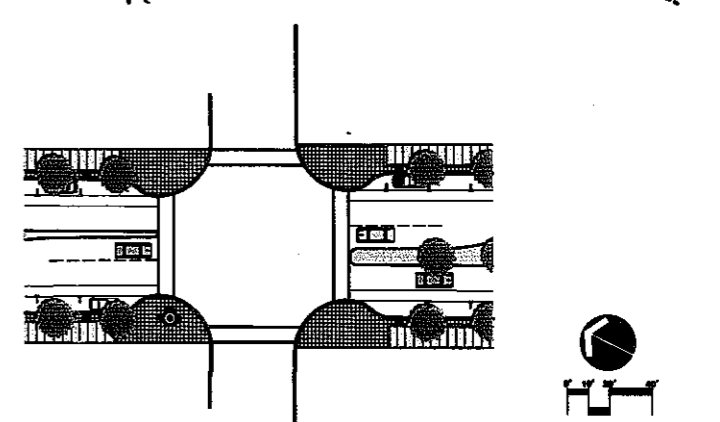
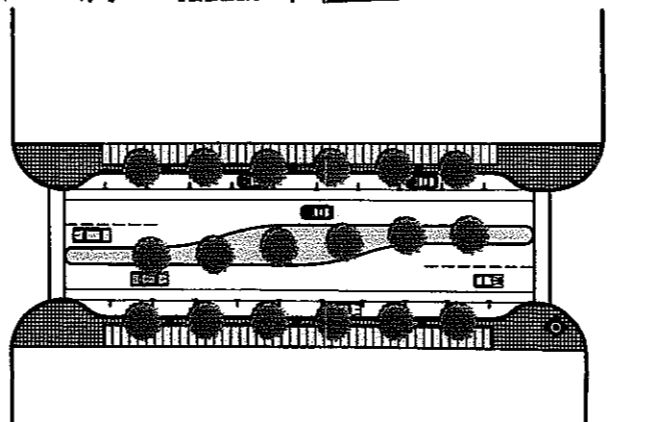
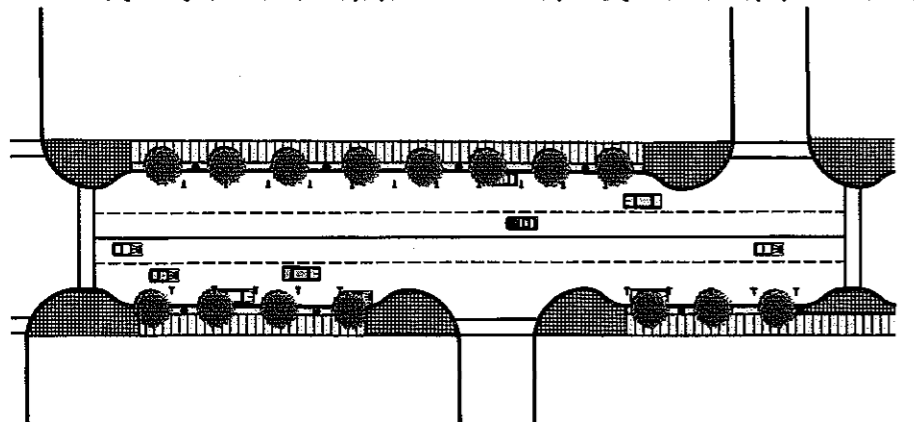
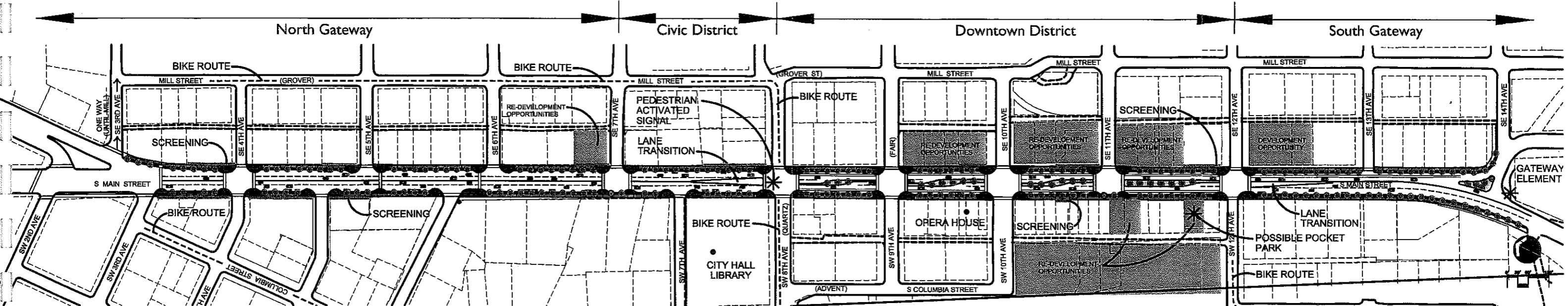

TYPICAL GATEWAY BLOCK

TYPICAL DOWNTOWN BLOCK

TYPICAL DOWNTOWN INTERSECTION

STREET SECTION OPTIONS

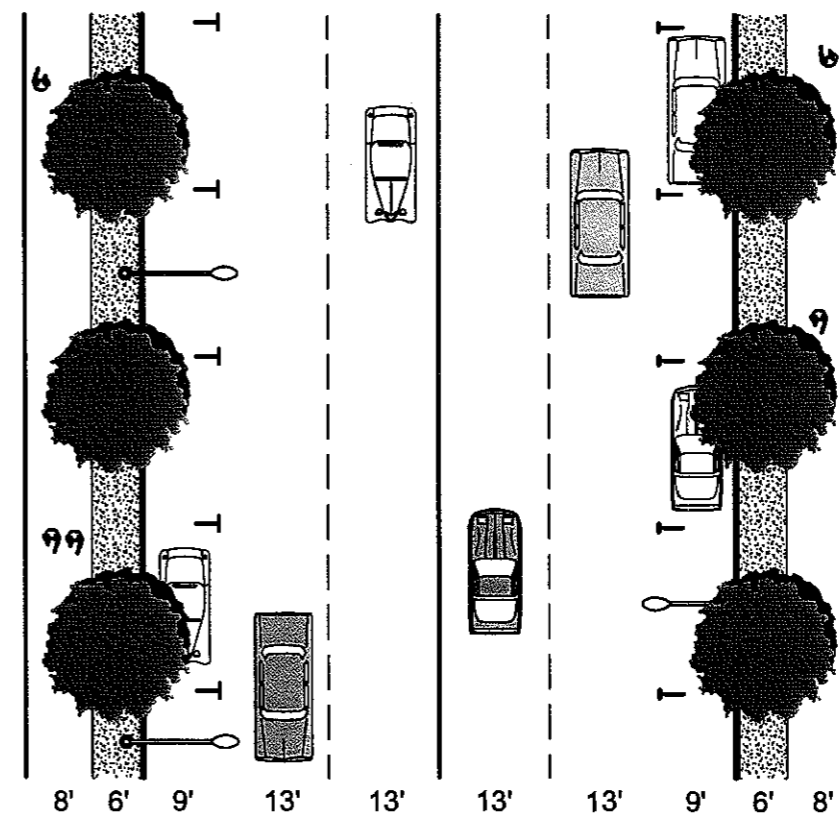
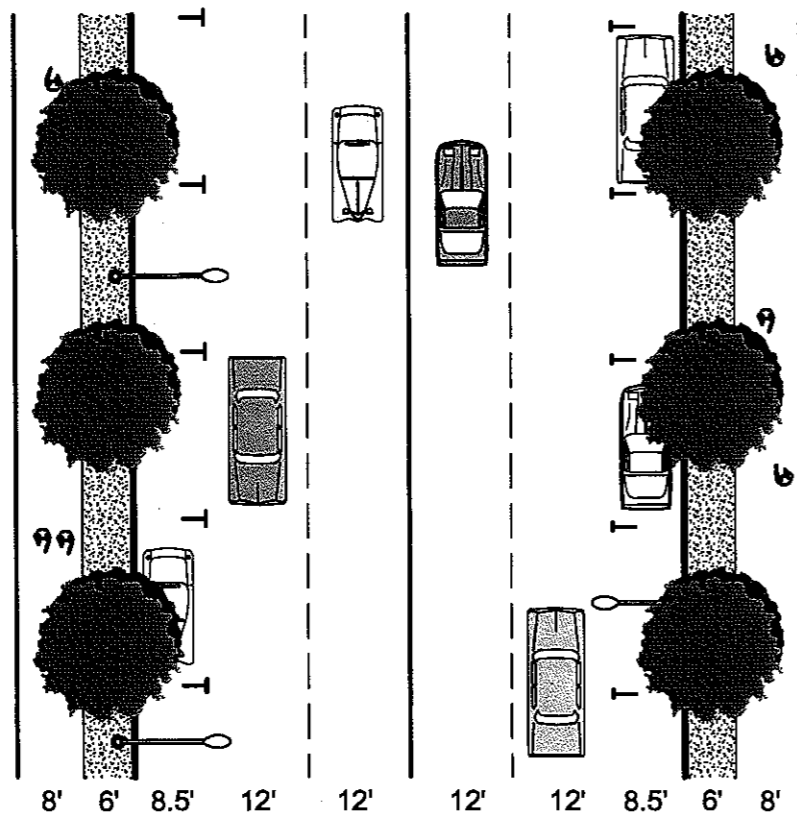
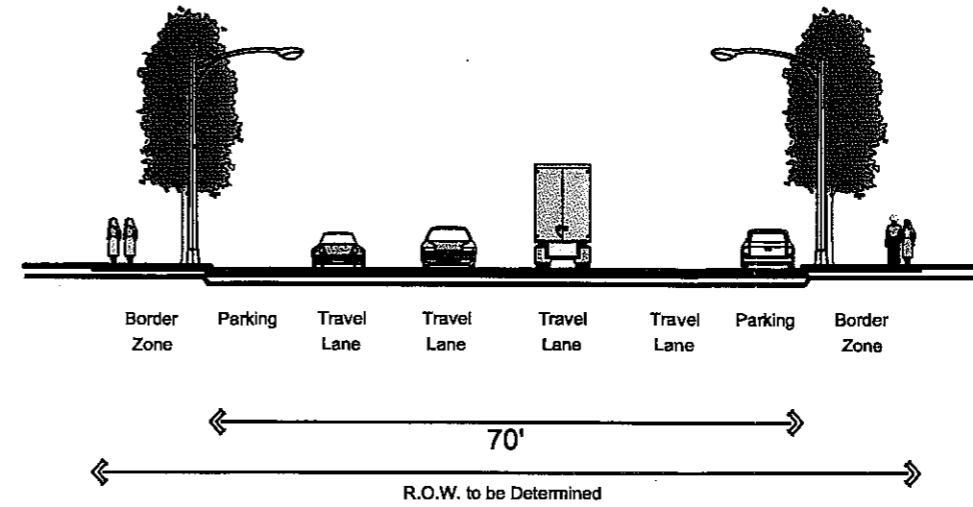
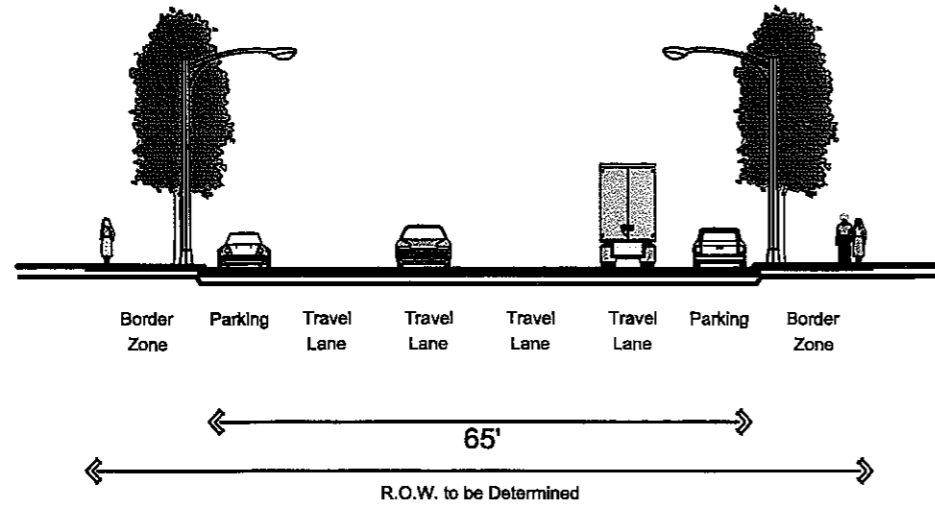

4 Lane Street
 No Turn Lane or Median
 Parking on Both Sides
 No Bike Lanes



Special Transportation Area Plan and Transportation System Plan Update



STREET SECTION OPTIONS

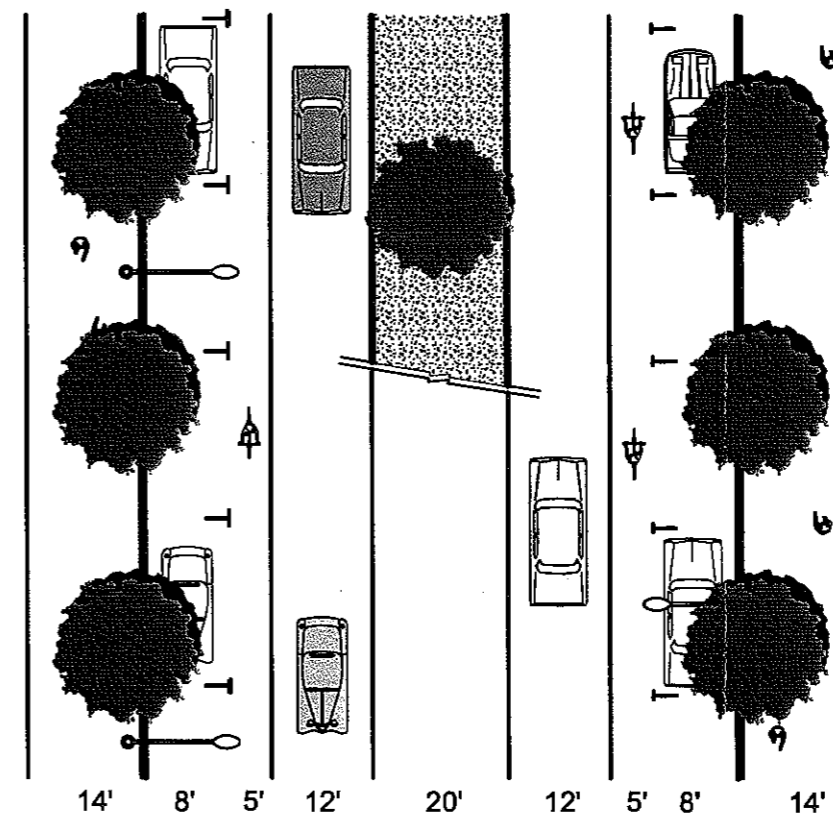
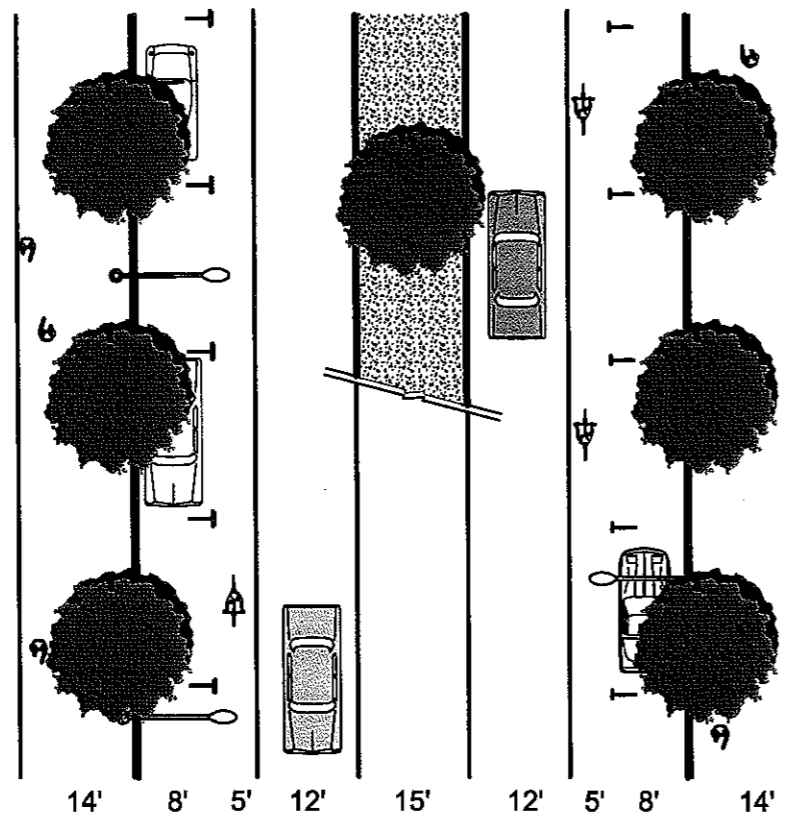
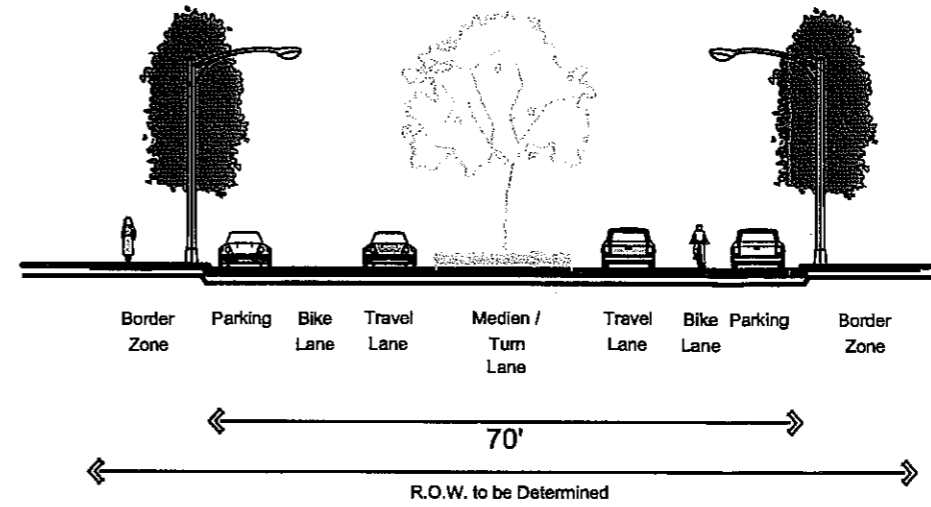
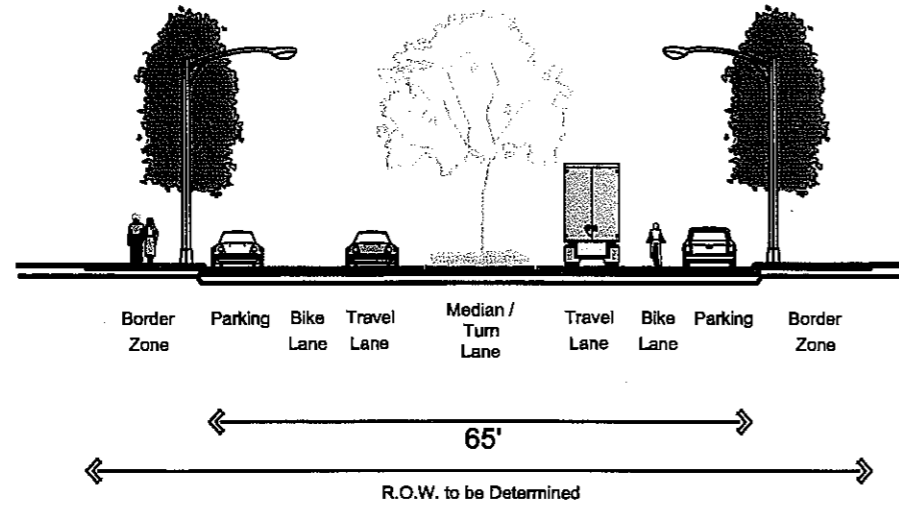

2 Lane Street
Center Turn Lane with Optional Median
Parking on Both Sides
With Bike Lanes



Special Transportation Area Plan and Transportation System Plan Update



STREET BORDER SECTION OPTIONS

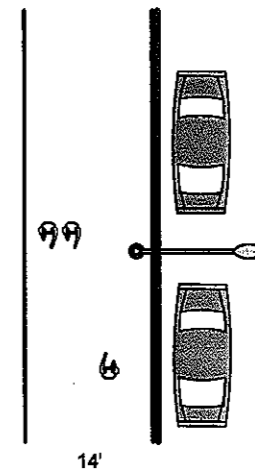
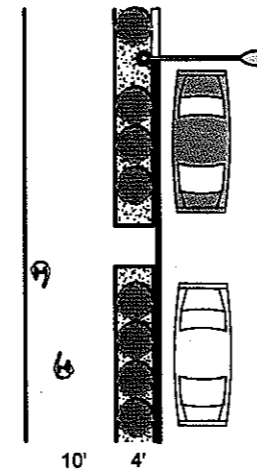
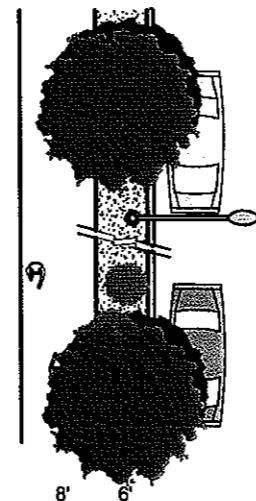
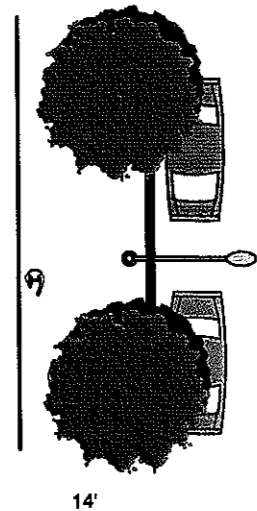
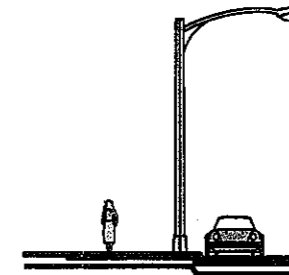
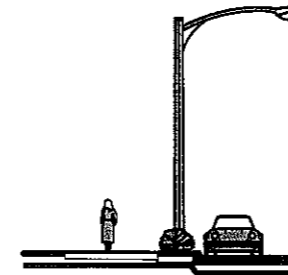
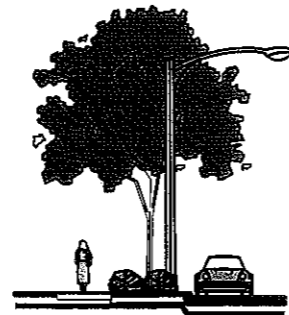
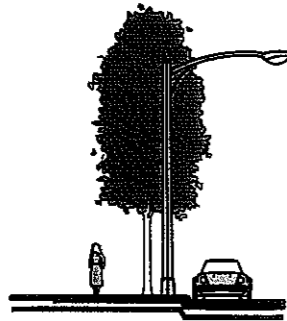

Sidewalk and Tree Grates

Sidewalk and 6' Planter Strip

Sidewalk and 4' Planter Strip

Sidewalk Only

STRONG PREFERENCE

STRONG PREFERENCE



Special Transportation Area Plan and Transportation System Plan Update



SIDEWALK PATTERN OPTIONS

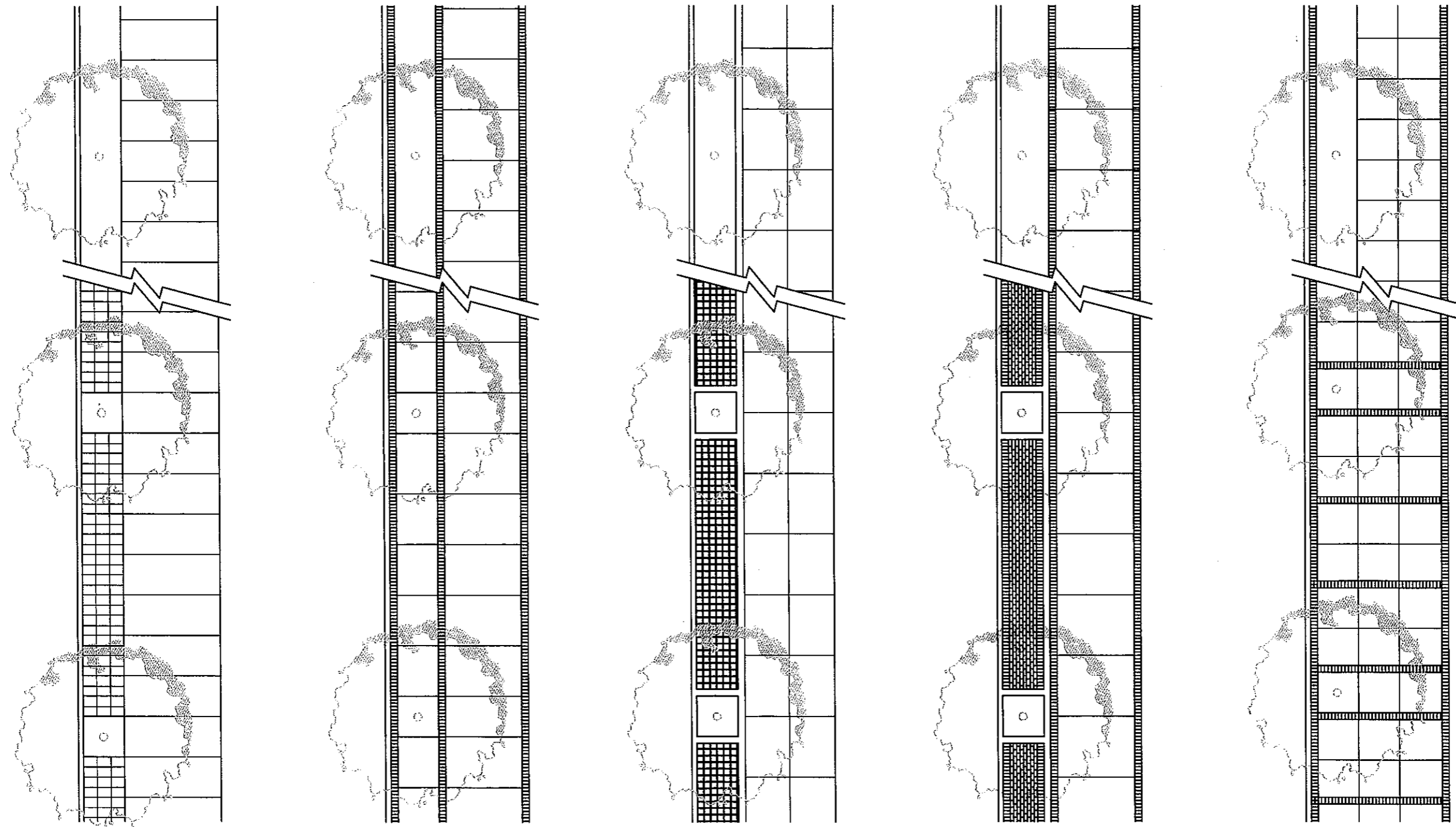

Special Transportation Area Plan and Transportation System Plan Update



CROSSING OPTIONS

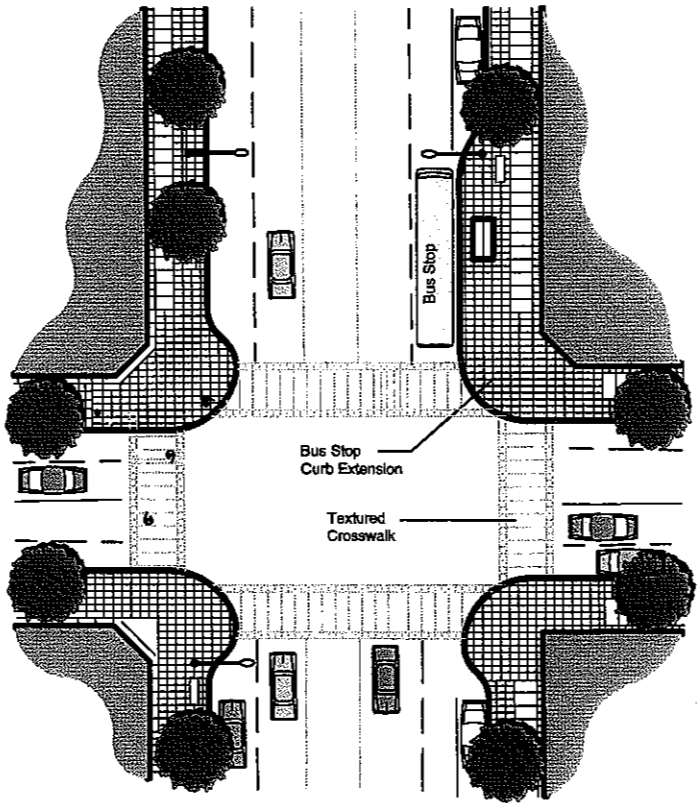
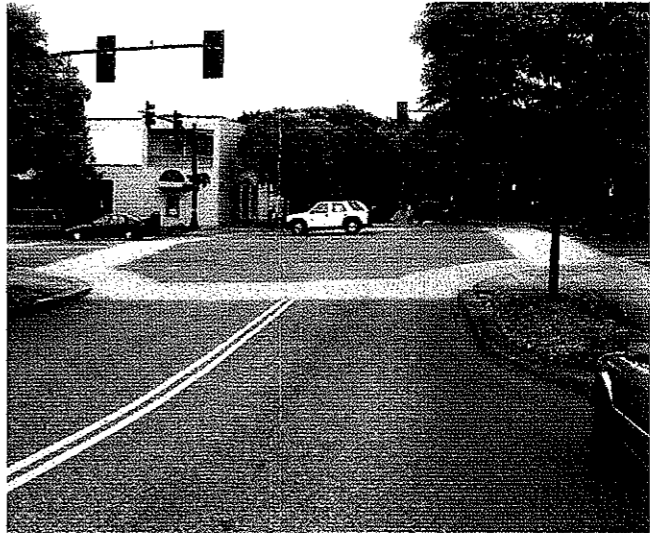
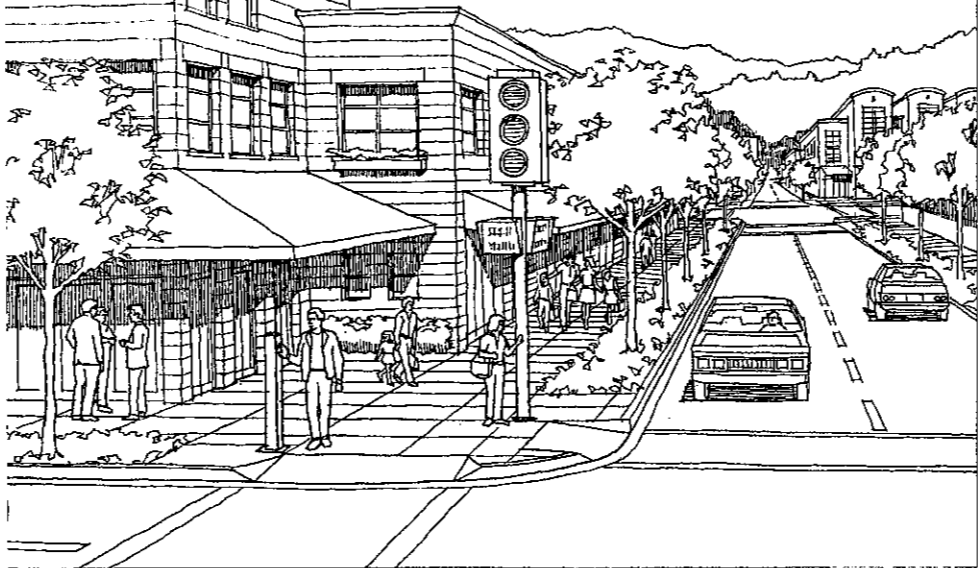

Curb Extension with
Parking on Both Sides
and Bus Stop
STRONG PREFERENCE



Special Transportation Area Plan and Transportation System Plan Update



STREET FURNISHINGS AND PUBLIC ART: STRONG PREFERENCE

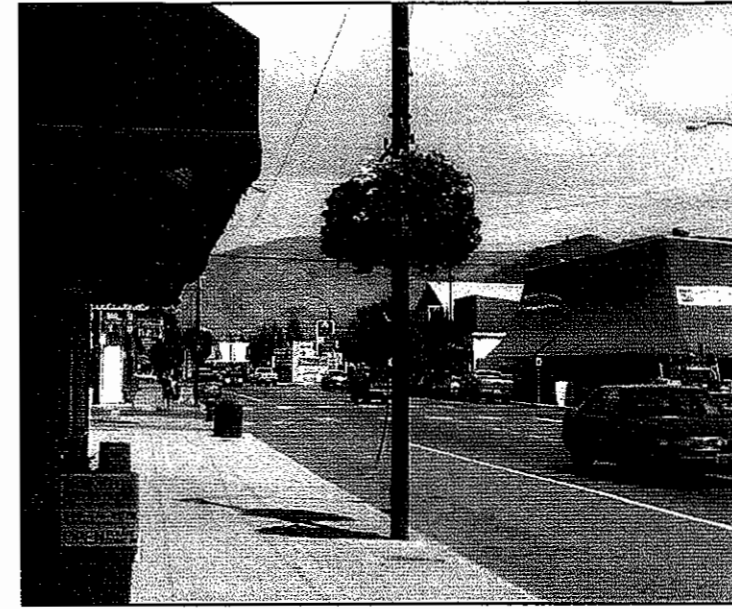
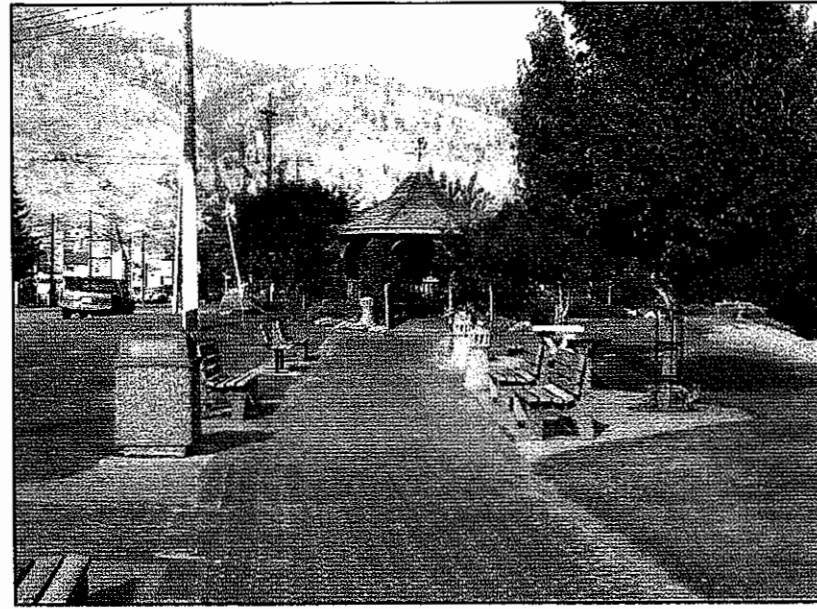

Special Transportation Area Plan and Transportation System Plan Update



STREET FURNISHINGS AND PUBLIC ART: SECONDARY PREFERENCE

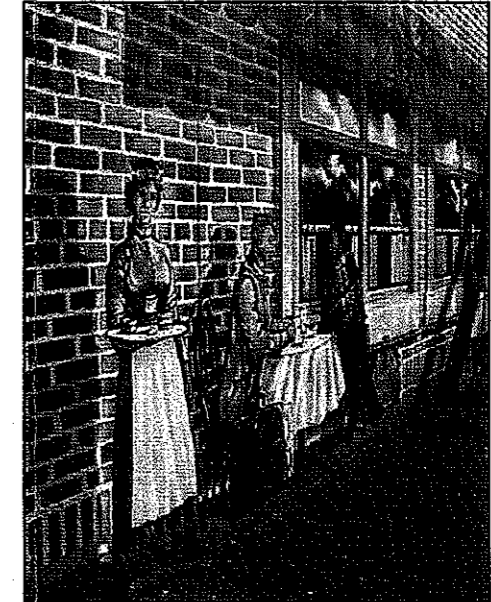
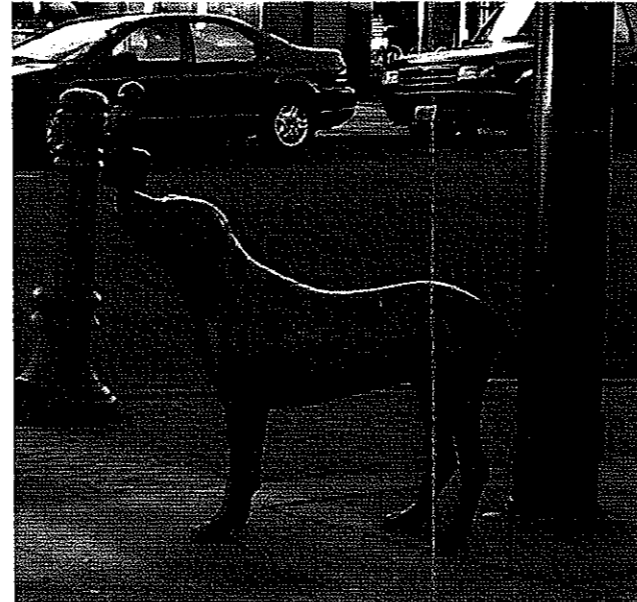

Special Transportation Area Plan and Transportation System Plan Update



LOGO OPTIONS

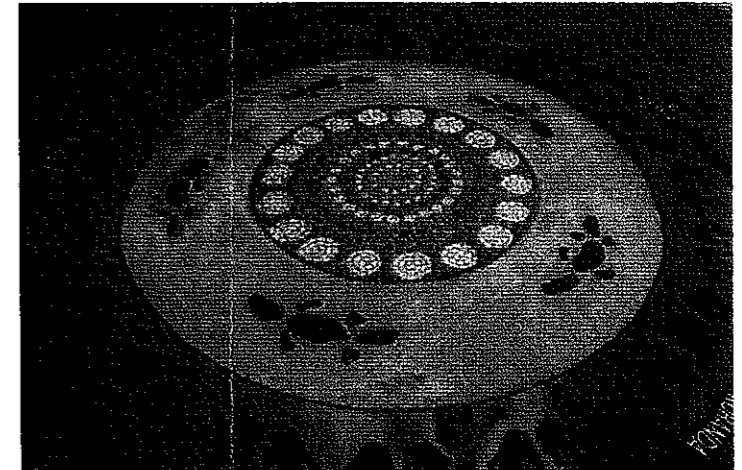
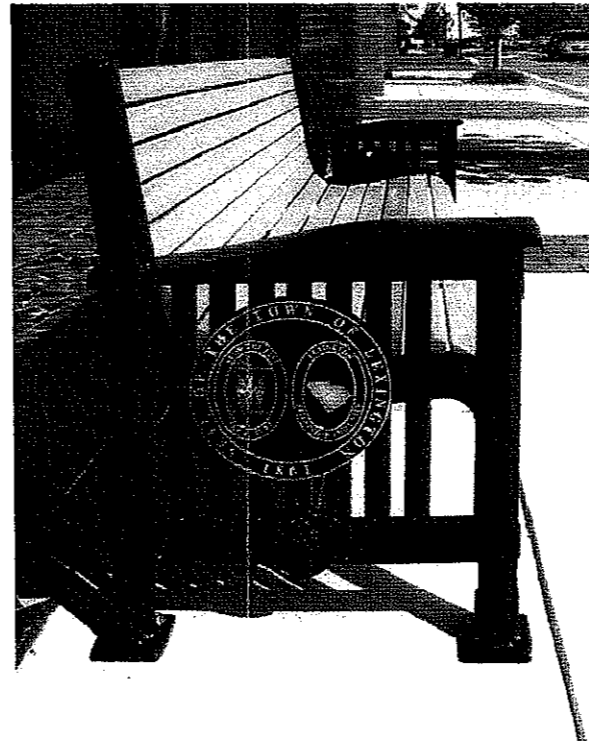
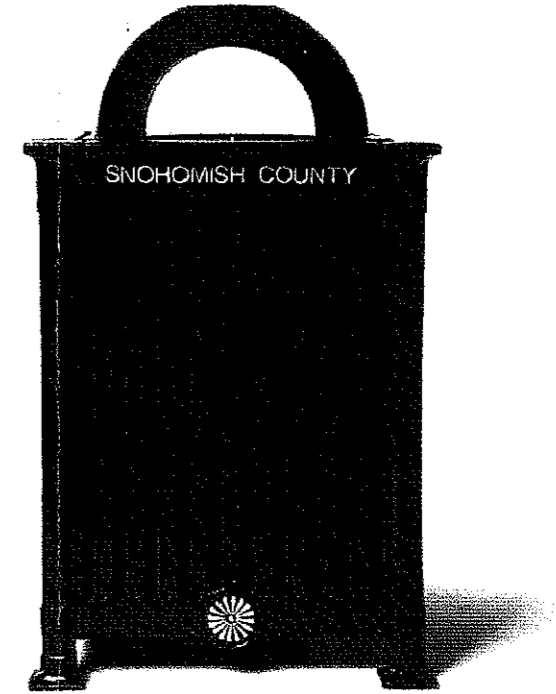
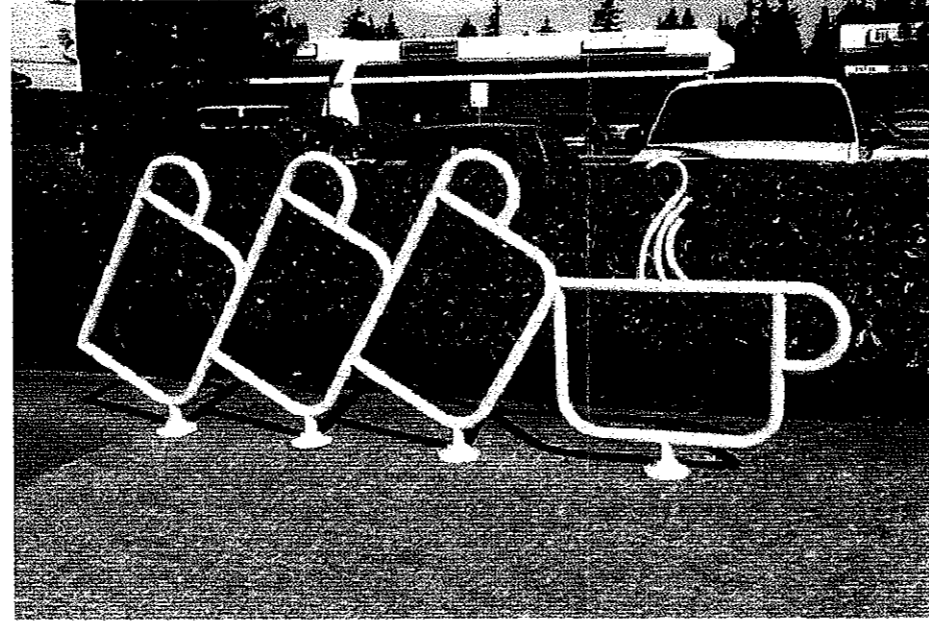
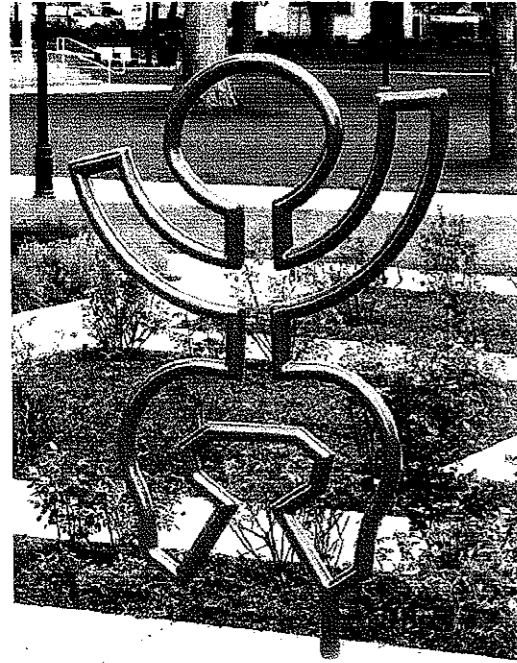

otak



Special Transportation Area Plan and Transportation System Plan Update



GATEWAY EXAMPLES

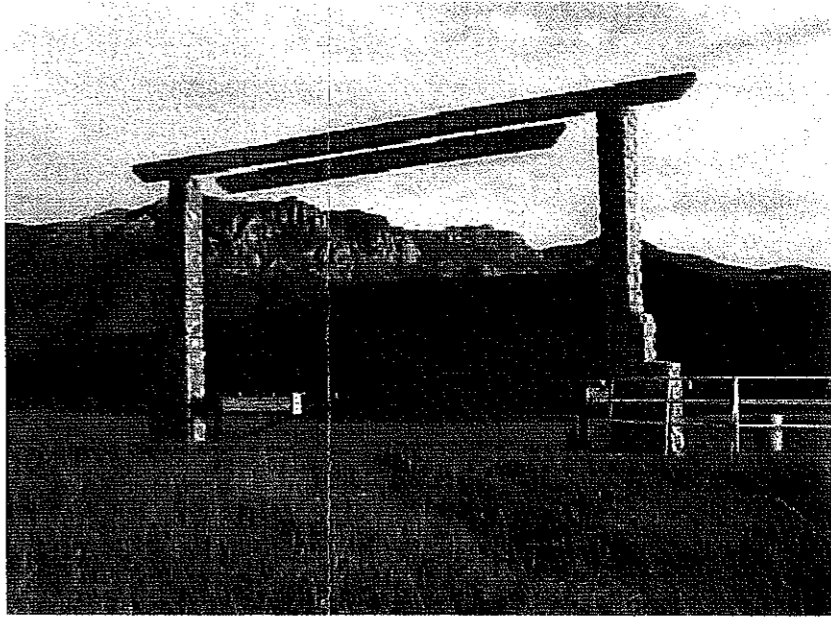
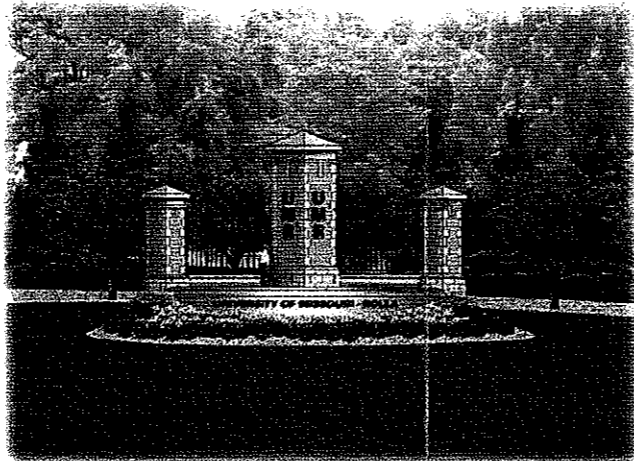
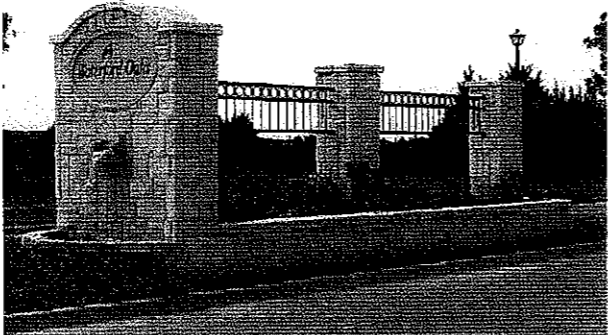
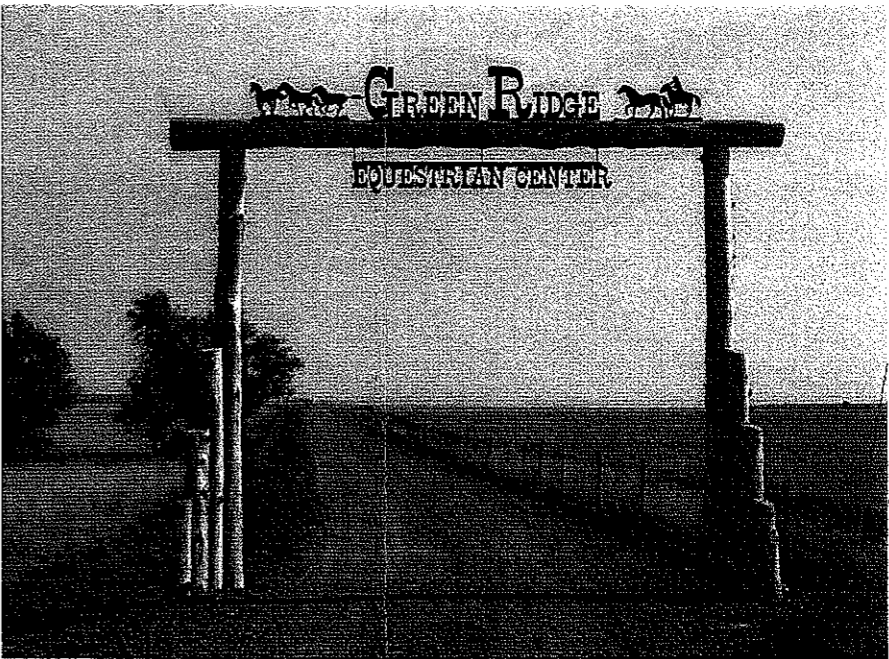
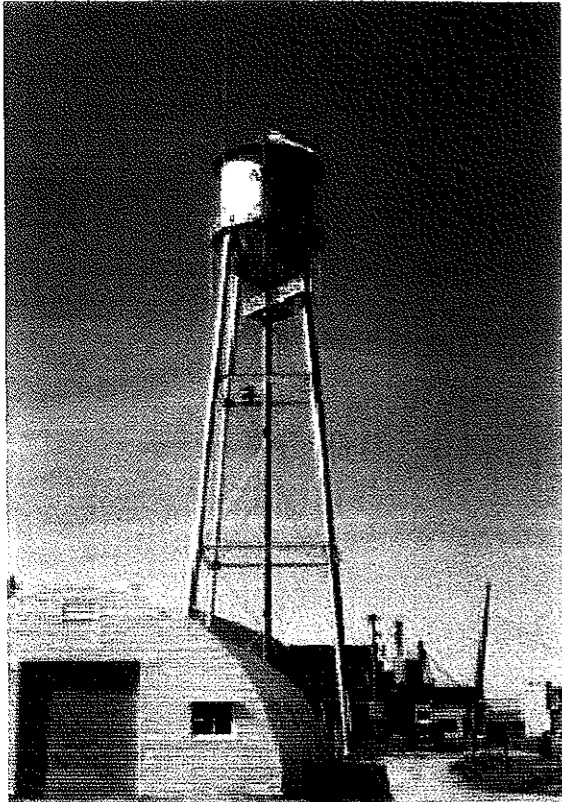

Special Transportation Area Plan and Transportation System Plan Update



STREET IMPROVEMENT PERSPECTIVES

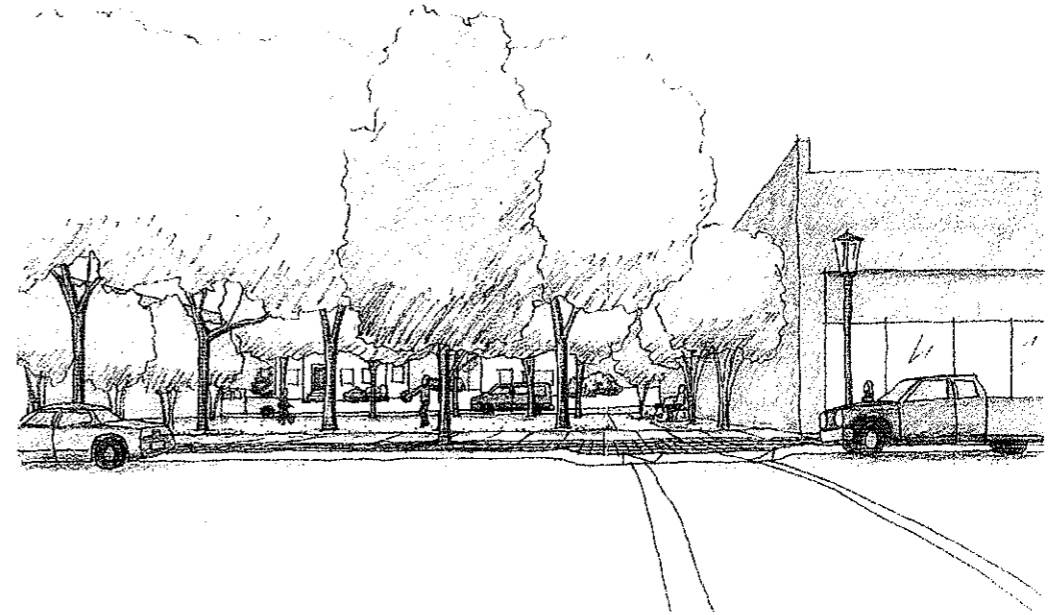
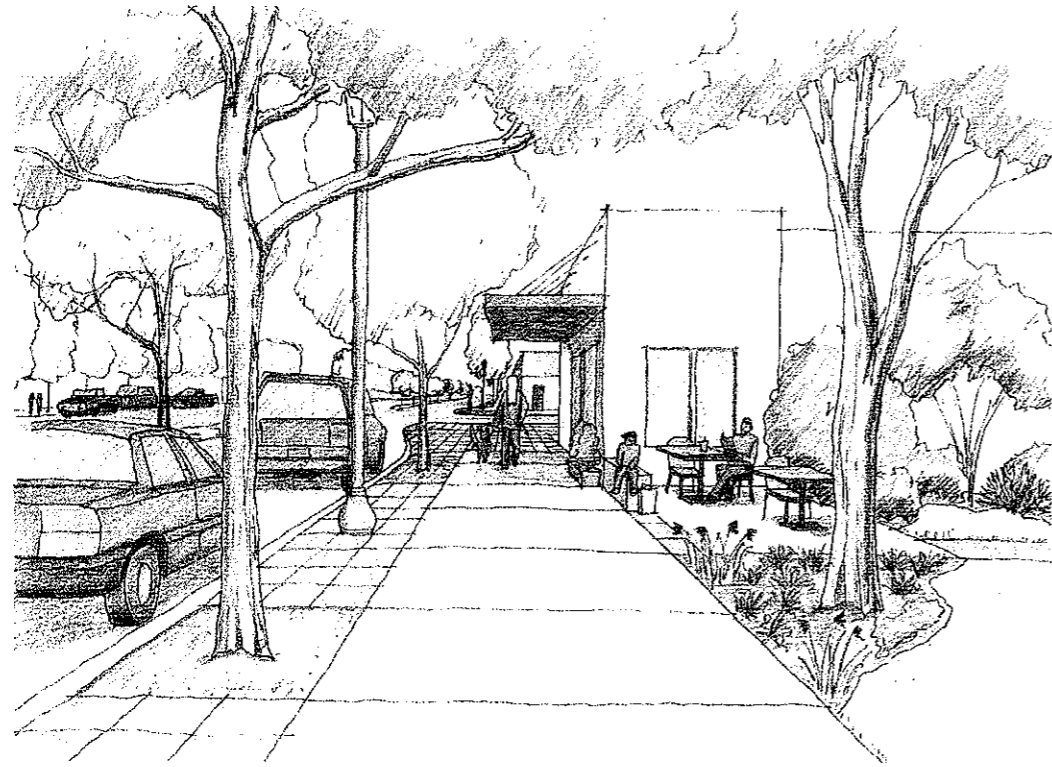

Special Transportation Area Plan and Transportation System Plan Update



BUILDING FACADE AND ALLEYWAY IMPROVEMENT PERSPECTIVES

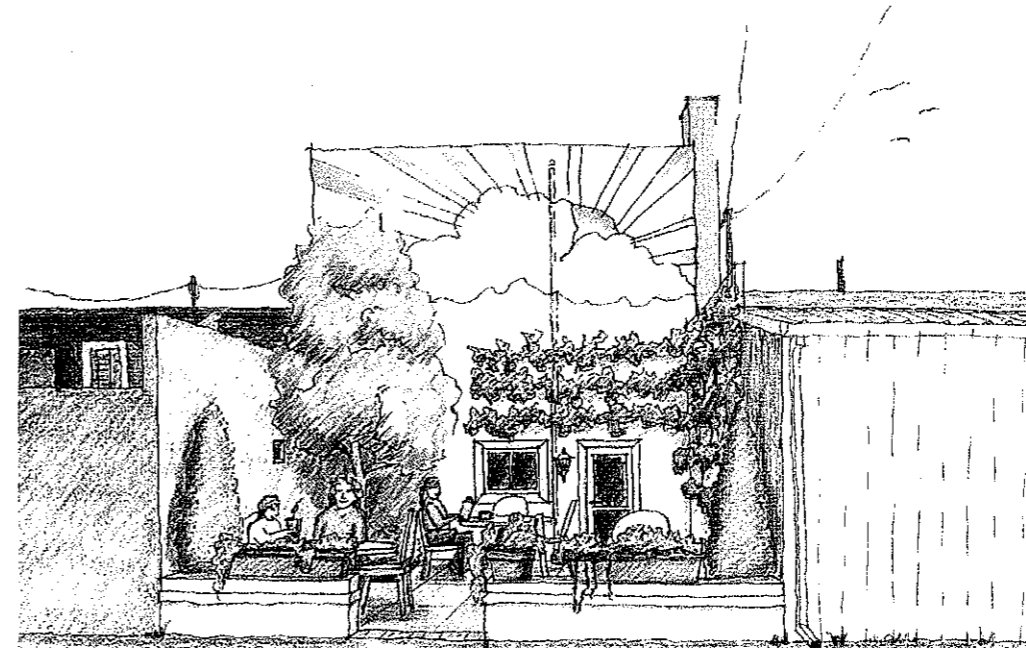
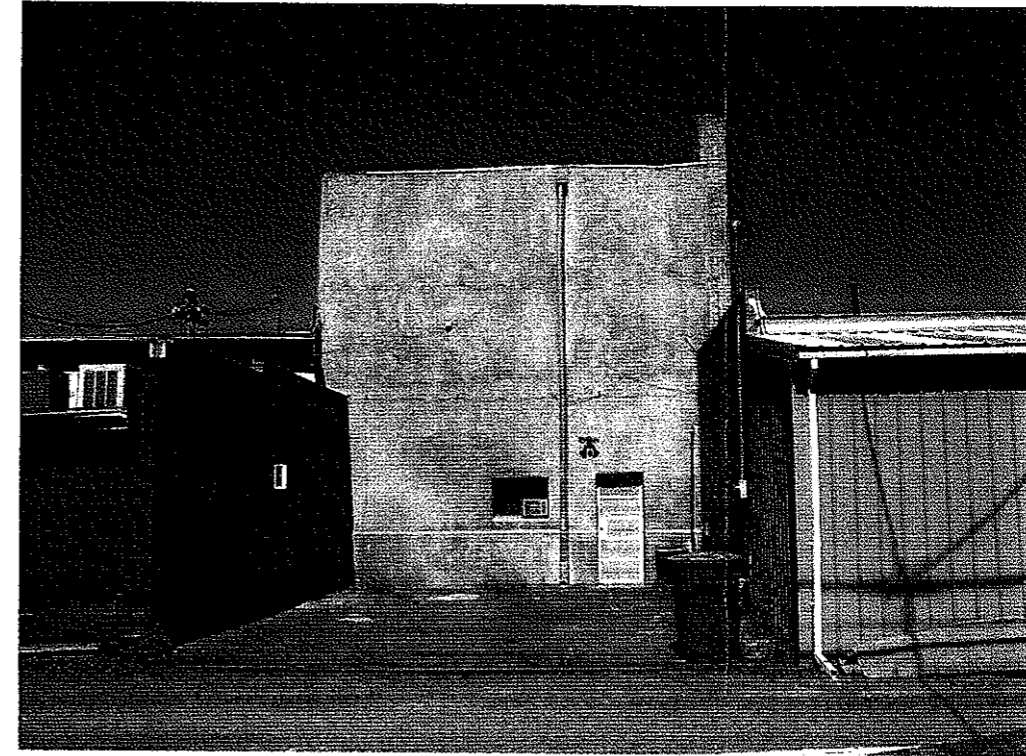





Special Transportation Area Plan and Transportation System Plan Update





PROPOSED ZONING

EXISTING

	R-2		C-1
	R-3		C-2
			I-M

NEW

	CV	CIVIC OVERLAY DISTRICT
	DB	DOWNTOWN BUSINESS
	MSR	MAIN STREET RESIDENTIAL

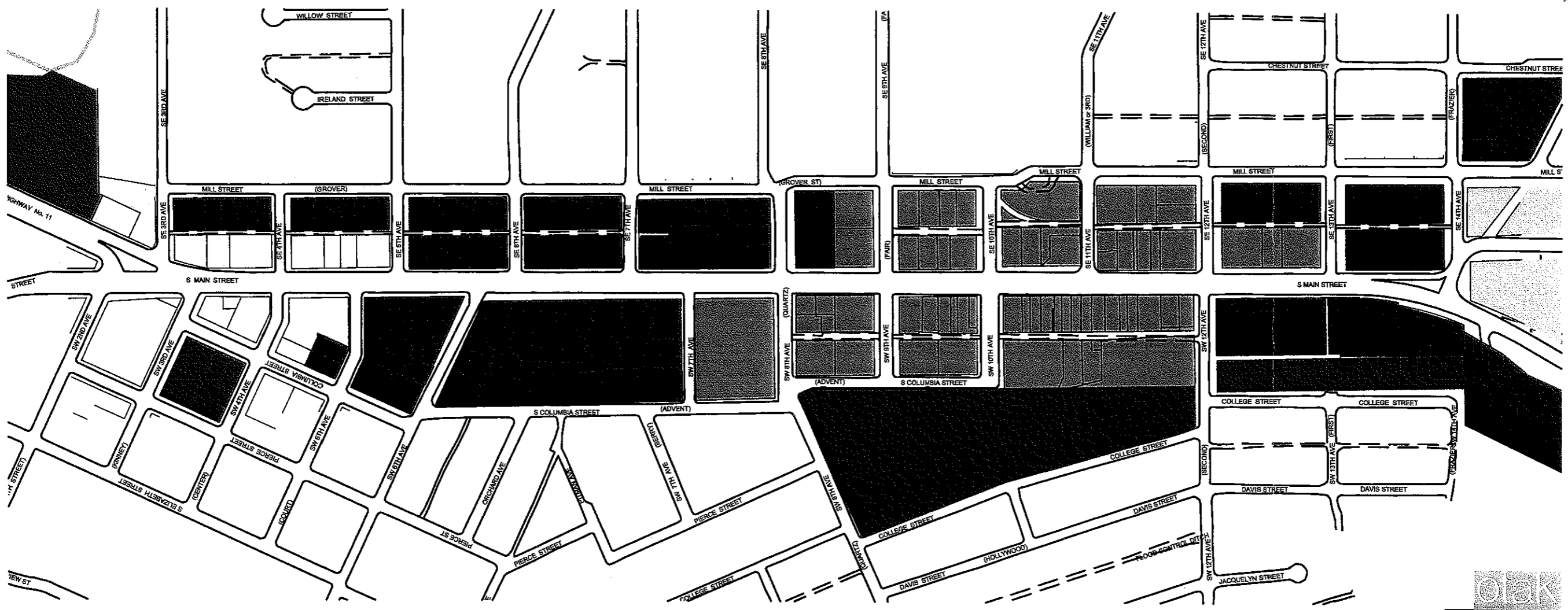

Special Transportation Area Plan and Transportation System Plan Update





KITTELSON & ASSOCIATES, INC.

TRANSPORTATION PLANNING/TRAFFIC ENGINEERING

610 SW ALDER, SUITE 700 • PORTLAND, OR 97205 • (503) 228-5230 • FAX (503) 273-8169

TECHNICAL MEMORANDUM

Milton Freewater STA and TSP Update Traffic Analysis

Date: June 2, 2005

Project #: 6743

To: Kay Van Sickle, OTAK

From: Elizabeth Wemple, P.E., Sagar Onta, P.E.

cc: Cheryl Jarvis-Smith, ODOT

INTRODUCTION

As a sub-consultant to OTAK, Kittelson & Associates, Inc. (KAI) conducted the traffic operations analysis for the update of the City of Milton-Freewater Transportation System Plan (TSP) to reflect the development of the City's Special Transportation Area (STA). The STA has been adopted by the Oregon Transportation Commission and extends from SE 14th Avenue at the south end of downtown to SW 2nd Avenue at the north end of downtown on ORE 11. The goals of the STA are to increase the vibrancy of Downtown Milton-Freewater, reduce vehicle travel speeds and encourage non-auto modes of transportation.

To assist the project team, KAI conducted an inventory of transportation related infrastructure and an analysis of existing transportation conditions. This analysis served as a foundation for developing and analyzing alternative transportation system improvements. KAI has also conducted an analysis of future year conditions in order to assess the impact of possible modifications to ORE 11 through downtown Milton-Freewater.

RECOMMENDATIONS

Based on the findings of the traffic operations analysis, it will be possible to convert ORE 11 to a three-lane facility from the vicinity of SW 8th Avenue to the vicinity of SW 14th Avenue. Under existing a.m. and p.m. peak hour conditions, if this configuration were implemented all study intersections would meet the ODOT volume-to-capacity ratio standard for Special Transportation Areas. By the forecast year of 2025 a.m. and p.m. peak hour conditions, all study intersections will continue to meet ODOT volume-to-capacity ratio standard.

EXISTING CONDITIONS

Transportation Facilities

As shown in Figure 1, the study area includes ORE 11 (i.e. S Main Street) from SW/SE 14th Avenue to SW/SE 2nd Avenue, Mill Street from SE 3rd Avenue to SE 14th Avenue, and Columbia Street from SW 10th Avenue to SE 3rd Avenue. Figure 2 shows intersection control within the study area. There are no bike lanes within the project study area.

Table 1 shows the functional classification and cross-sectional characteristics of the roadways within study area roadways. The classifications reported are those from the 1999 TSP (David Evans & Associates, Inc. 1999) and the 1999 Oregon Highway Plan (OHP).

Table 1 Existing Roadway Characteristics

Roadway	Jurisdiction	Classification	Cross-Section	Roadway Width	Posted Speed	Bike Lanes	Side-walk	On-Street Parking
OR 11 - S Main Street	ODOT	Statewide Highway - ODOT	4 Lanes	65' - 70'	25 mph	No	Yes	Yes
		Arterial - City	4 Lanes	65' - 70'	25 mph	No	Yes	Yes
SE 14 th - 15 th Ave	City	Collector - City	2 Lanes	35' - 40'	25 mph	No	Yes	Yes
SE 9 th Avenue	City	Collector - City	2 Lanes	40'	25 mph	No	Yes	Yes
Columbia Street	City	Local Street - City	3 Lanes	32' - 36'	25 mph	No	Yes	Yes
Mill Street	City	Local Street - City	2 Lanes	30'	25 mph	No	Yes	Yes
Other Streets	City	Local Street - City	2 Lanes	30' - 40'	25 mph	No	Yes	Yes

Vehicle Operations

The Oregon Department of Transportation (ODOT) collected intersection turning movement counts (14-hour data) in November 2004, December 2004 and January 2005. The raw traffic volumes were balanced across the project study intersections to better reflect anticipated gains and/or losses in traffic as traffic flows from one end of Downtown to the other.

Per ODOT standards, this memo presents the analysis of "30th highest hour traffic volumes". On an annual basis, hourly traffic counts will vary by month of the year, and week and day of the month. ODOT has historical data and seasonal factors for the majority of the roads throughout the state to convert a traffic count to its equivalent 30th highest hour volume. *Appendix A contains the raw, seasonally adjusted traffic counts and balancing analysis information.*

Figures 3 and 4 show the seasonally adjusted peak hour traffic volumes and resulting level of service for the weekday a.m. and p.m. peak hours, respectively. The level of service analysis was conducted according to 2000 Highway Capacity Manual procedures. The analysis was conducted based on a saturation flow rate of 1,800 vehicles per hour, as required by ODOT. ORE 11 within the study area is classified as a Statewide Highway in the 1999 OHP and as a STA according to the OTC. Accordingly, the volume to capacity ratio standard of a minor street approach to an

unsignalized intersection is equivalent to a district highway/local street standard of 0.95. At signalized intersections the volume to capacity ratio requirement for statewide highways within an STA is 0.90. *Appendix B includes the existing conditions level of service analysis calculation sheets.*

As shown in Figures 3 and 4, under the existing four-lane cross-section of ORE 11 from SW 14th Avenue to SW 2nd Avenue, all of the study intersection operate acceptably during both the weekday a.m. and p.m. peak hour periods. None of the study intersections were found to operate at high volume to capacity ratios.

Parking Supply and Demand

On-Street Parking

On-street parking supply by type, utilization, and block face was inventoried on Thursday, November 11, 2004, between 11:00 a.m. and 1:00 p.m. Figure 5 shows a summary of the parking supply inventory. In addition, this figure shows the utilization of these parking spaces on this typical weekday. Marked parallel parking spaces were observed between SW 8th Avenue and SW 12th Avenue. All other parking spaces are not marked, but available for parking.

For most Downtowns, parking demand is the highest during this mid-day period or just after lunchtime in the early afternoon. During the data collection period the highest parking demand was observed between SW 10th Avenue and SW 12th Avenue on ORE 11. The higher density of commercial establishments in the area contributes to the high parking demand. Otherwise on-street parking in downtown Milton-Freewater was well under capacity.

Off-Street Parking

Off-street parking data were collected on Friday, March 4, 2005, between 11:00 a.m. and 1:00 p.m. Figure 5 also shows the location of off-street public surface parking areas available in the study corridor. There are four off-street parking lots in the corridor. The northern most lot is located on the west side of ORE 11 between SW 5th Avenue and SE 5th Avenue, adjacent to an existing church. The lot is able to accommodate approximately 20 parking. The second off-street parking lot is located on the northeast quadrant of SE 7th Avenue/ORE 11 intersection and is able to accommodate approximately 10 parking spaces. The third public surface parking is located behind the City Hall and the Library between SW 7th Avenue and SW 8th Avenue, and is able to accommodate approximately 40 parking spaces. The old industrial mill site between SE 10th Avenue and SE 11th Avenue on SE Mill Street is the fourth off-street surface parking lot that can accommodate approximately 60 parking spaces. All the off-street parking spaces were well under utilized when the data was collected except the lot behind the City Hall, which was approximately 50% full.

The data collection effort also revealed several private retail/commercial businesses in the study area with dedicated parking spaces for the customer and employees. The majority of these lots are on the north end of the corridor, from SW 2nd Avenue to SW 6th Avenue, and a few others in the rest of town. A total of approximately 180 off-street business parking spaces are available in the study area. Of those, 130 off-street business parking spaces are located between SW 2nd

Avenue and SW 6th Avenue, 45 spaces are located between SE 7th Avenue and SE 8th Avenue and approximately 5 off-street business parking spaces are located from SE 8th Avenue to SE 14th Avenue. In the future, if parking demand increased dramatically, it is possible that the private business parking spaces could be integrated into the publicly available supply as part of an overall parking management plan for downtown Milton-Freewater.

Access

ODOT has access management policies to preserve mobility on State facilities. According to the 1999 Oregon Highway Plan, Oregon 11 through Downtown Milton-Freewater is classified as a statewide highway facility. Therefore according to ODOT access management policies there can be public access points (streets) every 550 feet. Private accesses points are discouraged.

According to the 1999 OHP, if a section of statewide highway is designated as Special Transportation Area (STA), as adopted for ORE 11 between SW 14th and SW 2nd, "direct street connections and shared on-street parking are encouraged" and "local auto, pedestrian, bicycle and transit movements to the area are generally given more importance than the through movement of traffic". In case of public roadway spacing, the existing city block or the city block spacing as identified in the local comprehensive plan is an accepted norm. For private driveways, minimum driveway spacing of 175 feet, measured from center to center on the same side of the roadway, is allowed.

Figure 6 shows the location of the existing accesses and their spacing in Downtown Milton-Freewater. As shown in the figure, majority of the existing accesses do not meet the ODOT access spacing standard for a STA. Nonetheless, due to the low traffic volume in the area, and historically low number of crashes, the existing accesses are anticipated to operate safely and acceptably.

As re-development within the STA occurs, the City of Milton-Freewater should plan to manage access points (i.e. consolidate and/or eliminate access points) to ORE 11 so that the ODOT STA access spacing standard is achieved. Optional access management strategies that could be considered with property redevelopment include:

- Eliminating multiple access points to one property;
- Implementing one shared access point to two or more properties;
- Modifying zoning requirements to avoid the need for on-site parking or circulation;
- Consolidating multiple properties to single lots for simplified access requirements; or
- Providing development benefits to property owners who eliminate their access point to ORE 11

Transit

There is no bus service in Downtown Milton-Freewater or service connecting Milton-Freewater and Walla Walla, Washington. One taxi service is available providing door-to-door transportation on request. Greyhound has recently discontinued its service in the area. There is one transit shelter on Ore 11 between SW 8th Avenue and SW 9th Avenue in Downtown Milton-Freewater, which is not in use.

Pedestrian and Bicycle Facilities

There are sidewalks on almost all streets in the study area except on the east side of Columbia Street from SW 6th Avenue to SW 7th Avenue. On SE 6th Avenue, partial sidewalk is present from S Main Street to the east end of the road.

Milton-Freewater staff indicated that most pedestrians cross ORE 11 at SW 8th, 9th, 10th and 12th Avenues in the downtown. The primary pedestrian generators in the downtown include: the library at SW 8th, Central Middle School on SW 2nd, and Grove Elementary School on SE 15th Avenue, and several churches along ORE 11 and in close proximity to the study area.

It is likely that the residents around Columbia Heights use the school crossing on SW 12th Avenue to travel to and from Grove Elementary School

There are no striped bicycle lanes in Downtown Milton-Freewater.

Pedestrian and bicycle facilities should be integrated into Downtown design concepts to encourage people to walk or bike to the many possible activity areas (e.g. library, City Hall, Church, schools, parks, etc.) in Downtown.

Crash Conditions

The crash history of ORE 11 from SW 14th Avenue to SW 2nd Avenue was reviewed in an effort to identify potential intersection safety issues. Crash records were obtained from the Oregon Department of Transportation's Transportation Data Section for the five-year period from January 1, 1999 through December 31, 2003. Table 2 summarizes details of the crash history at the project study intersections.

Overall, between 1999 and 2003 there were 18 reported crashes on the corridor. The majority of crashes occurred at the intersections of ORE 11/ SW 2nd Avenue (four crashes in the five-year period), ORE 11/SW 4th Avenue (four crashes in the five-year period) and ORE 11/SW 12th Avenue (three crashes in the five-year period). There were no fatal crashes identified in the ODOT data set. The crashes are evenly distributed between those causing injury and those causing only property damage. Based on the review of the crash data, no reoccurring crash patterns were observed in the data and no safety concerns were identified for the study area. In addition, the crash rates for each intersection (crashes per million entering vehicles) are also shown in Table 2. These intersection crash rates are relatively low, and reveal no apparent problems

For segments, ODOT maintains statewide data documenting crash rates per million vehicle miles by segment type. This data shows that for rural non-freeways the 2003 statewide average crash rate was 1.40 crashes per million vehicle miles. ORE 11 from SW 14th Avenue to SW 2nd Avenue is approximately 1.04 miles long; average daily traffic along this segment is approximately 11,000 vehicles per day. Given that there were 18 crashes between 1999 and 2003, the calculated crash rate is 0.86 crashes per million vehicle miles. This is below the statewide average and again does not reveal any high crash locations. *Appendix C includes the crash data provided by ODOT.*

Table 2 Summary of Intersection Crashes (1999-2003)

Intersection	Total	Collision Type				Severity			Peak-hour Volume	Crash Rate ³
		Rear End	Turning	Angle	Other ¹	PDO ²	Injury	Fatality		
ORE 11/SW 14 th Ave	1	1				1			1,090	0.05
ORE 11/SW 13 th Ave	0								1,175	0.00
ORE 11/SW 12 th Ave	3	1	2			2	1		1,235	0.13
ORE 11/SW 11 th Ave	1		1			1			1,235	0.04
ORE 11/SW 10 th Ave	1	1				1			1,250	0.04
ORE 11/SW 7 th Ave	1		1				1		1,220	0.04
ORE 11/SW 5 th Ave	2	1		1		1	1		1,300	0.08
ORE 11/SW 4 th Ave	4	2	2			1	3		1,305	0.17
ORE 11/SW 3 rd Ave	1		1				1		1,325	0.04
ORE 11/SW 2 nd Ave	4	2	1		1	2	2		1,600	0.14
Total	18	8	8	1	1	9	9	0		

¹ Other collision types include a collision with an animal, fixed object, mechanical failure, and other single-vehicle non-collisions.

² PDO represents "property damage only."

³ Crashes per million entering vehicles.

FUTURE CONDITIONS – NO CHANGE TO THE TRANSPORTATION SYSTEM

Traffic Volumes

The 2004 traffic volumes were forecast to 2025 conditions assuming a 1.6-percent per year growth factor. The factor was developed based on the review of the data obtained from the ODOT's permanent Automatic Traffic Recorder, Milton 30-021, located on ORE 11, 0.9 miles south of the Oregon-Washington state line (MP 34.46), ODOT Traffic Volume Tables, and the Milton-Freewater Transportation System Plan (TSP). This growth rate was compared to the traffic volumes and growth rates used in the 1999 TSP and the traffic volumes that were recently obtained by ODOT for this project. ODOT Transportation Planning Analysis Unit (TPAU) Staff have reviewed and approved this growth factor.

Vehicle Operations

Assuming no improvements to the existing transportation system in Downtown Milton-Freewater, forecast year 2025 traffic operations are shown in Figures 7 and 8 for weekday a.m. and p.m. peak hour periods, respectively. As shown in the figures, all of the intersections meet ODOT STA volume-to-capacity ratio standards. *See Appendix D.*

FUTURE CONDITIONS - OPTIONAL MODIFICATIONS TO ORE 11 THROUGH DOWNTOWN MILTON-FREEWATER

Recognizing that a goal of this project is to develop a transportation system that supports a "main-street" concept for downtown, three optional modifications to ORE 11 were identified:

- Convert ORE 11 to a three-lane facility;
- Maintain ORE 11 as a four-lane facility and provide curb extensions or median island at key intersections; or
- Change the alignment of ORE 11 at SW 14th and SW 2nd Avenues.

The following sections describe the alternatives and results of the transportation operation analysis. The options were considered separately, though potentially all could be integrated into the future plan.

As requested by ODOT, the results of the traffic operations analysis have been compared to standards outlined in the Oregon Highway Design Manual (HDM). ORE 11 in this area is classified as a Statewide Highway, and as a result of this project is becoming a Special Transportation Area. As outlined in Table 10-1 of the HDM, the volume to capacity ratio standard is at or less than 0.90 for the mainline. Further, according to Action 1F.1 bullet two of the Oregon Highway Plan, the stop-controlled approaches to the roadway must operate according to the District/Local Interest Road classification. Again, according to Table 10-1 of the Highway Design Manual, the stop-controlled approaches to the study intersections must operate at or less than a volume to capacity ratio of 0.95

Three-Lane Roadway Alternative

Two of the primary goals of the project are to reduce vehicular speeds and encourage non-motorized transportation in Downtown Milton-Freewater. Subject to many considerations, converting ORE 11 to a three-lane facility would provide more public space for pedestrian, bicycle and aesthetic use, and could slow travel speeds through downtown. Currently, ORE 11 is 65 feet wide in the study area. If the roadway were converted to a three-lane cross-section with two 12-foot travel lanes and one 14-foot center left-turn lane, approximately 27 feet would be available to accommodate 8-foot on-street parking and 5-foot bike lanes on both sides of the street.

The following documents the results of the traffic operations analysis assuming that ORE 11 from SW 14th to SW 2nd Avenue was converted to a three-lane facility. This analysis was conducted as a hypothetical situation in order to test the operational impacts of the conversion.

2004 Vehicle Operations as Three-Lane Roadway

Figures 9 and 10 show the near-term operational characteristics of the study intersection under a three-lane scenario. As shown in the figures, in the near term all the intersection would continue to operate under capacity during both the weekday a.m. and p.m. peak hour periods. See Appendix E.

2025 Vehicle Operations as Three-Lane Roadway

Figures 11 and 12 show the forecast year 2025 a.m. and p.m. peak hour traffic operations assuming ORE 11 through downtown Milton-Freewater were converted to a three-lane facility. As shown in the figures:

- During the weekday a.m. peak hour:
 - All intersections are forecast to operate according to ODOT HDM standards except the intersection of ORE 11/SW 14th Avenue. This intersection is forecast to operate with an a.m. peak hour v/c ratio of 0.95 – just meeting the ODOT standard for volume to capacity ratios within an STA. The three-lane alternative will include providing a separate left and right-turn lane at the westbound approach to the intersection. This will minimize vehicle queuing and delay at the intersection.

- During the weekday p.m. peak hour:
 - All intersections are forecast to operate acceptably except the intersections of SW 8th Avenue and SW 7th Avenue at ORE 11. The eastbound left turn movements will operate at-capacity during the weekday p.m. peak hour. Traffic signal warrants are not met at these locations, and with alternate routes available it is anticipated that motorists will divert to other intersections along ORE 11 to avoid delay. Modifying the alternative to allow two-stage gap acceptance would mitigate this condition.

These results reflect a conservative analysis that includes a relatively low peak hour factor based on existing conditions; seasonally adjusted volumes that are higher than currently observed peak hours, and conservatively balanced traffic volumes. Therefore it is likely that the intersections will operate better than reported here. Further with the downtown grid system, drivers will have options to use alternate routes to avoid delay if desired. Given this it is likely that if in the future drivers experience delay during peak hours, it will be for short periods of time. There will not likely be capacity issues causing excessive queuing. *See Appendix F.*

Advantages and Disadvantages

Advantages

A three-lane section through Downtown Milton-Freewater would:

- Reduce the travel speed in the area due to lower total pavement width;
- Enhance the safety of the roadway due to lower operational speed;
- Provide a more attractive cycling environment due to lower operational speed; and
- Provide additional public space for wider sidewalks and streetscape features.

Disadvantages

Potential disadvantages of converting to ORE 11 to a three-lane roadway include:

- Due to the reduction in speed, there is a potential for the traffic on ORE 11 to divert to parallel roadways in the area.
- There may be increases in traffic noise in the vicinity of the transition to the three-lane facility as motorists apply their brakes.

Curb Extensions and Median Islands Alternative

An alternative to changing ORE 11 from four lanes to three lanes would be maintaining the corridor cross-section and providing traffic calming features throughout the corridor. These features would decrease the crossing distance for pedestrians and provide visual cues for motorists to travel at slower speeds.

The most common method is to provide curb extensions to shadow on street parking. Alternatively, the travel lanes can be transitioned such that a median refuge island is created in the middle of the roadway for the pedestrians to use when crossing the roadway.

Vehicle Operations

Implementing traffic calming features would not impact vehicle capacity and therefore the system would operate as forecast in the 2025 no-build condition.

Advantages and Disadvantages

Advantages

The advantages of curb extensions are:

- Enhance pedestrian environment.
- Provide additional sidewalk space
- Inexpensive to implement
- Negligible impact on vehicular traffic operation

The advantages of median islands are:

- Provide refuge for pedestrian while crossing the roadway
- Relatively inexpensive to implement
- Negligible impact on vehicular traffic operation

Disadvantages

The disadvantages of curb extensions are:

- Will show less speed reduction benefits than changing the cross-section from a four-lane to three-lane road.
- Slight decrease in total parking supply.

The disadvantages of median islands are:

- Design of the roadway transition would be critical for good operation, and to ensure that vehicles do not drive over the median islands.
- Sidewalk space will not increase to enhance pedestrian environment.

Geometric Considerations Alternatives

The focus of this project has been on re-vitalizing the downtown core of Milton-Freewater – Ore 11 from SE 12th Avenue to SE 6th Avenue. As success is achieved, the City should consider possible additional gateway projects to further enhance the vibrancy of Downtown Milton-Freewater. For future reference, optional concepts are described below. Further detailed analysis of these concepts would be required prior to implementation.

ORE 11/SW 14th Avenue Intersection

The intersection of ORE 11/SW 14th Avenue serves as a gateway to Downtown Milton-Freewater. There is a relatively steep downgrade as ORE 11 approaches this intersection from the south. Just south of the intersection, the posted speed limit changes from 45 miles per hour to 25 miles per hour – although the roadway cross-section does not support this travel speed.

Modifying the intersection of SW 14th Avenue/ORE 11 to include either a roundabout, subject to right of way availability, or by re-aligning the horizontal curve to slow travel speeds are optional methods for reducing travel speeds in this area. Either option could serve as a gateway project for the community.

ORE 11/SW 2nd Avenue Intersection

This intersection also serves as a gateway to Downtown Milton-Freewater. The high skew and multiple streets coming together at this location require complex lane striping and signal phasing. As Milton-Freewater grows, possible modifications at this intersection should be considered to simplify traffic operations. Possible improvements include a modern roundabout, subject to right of way availability, or possible closure of streets and realignment of ORE 11.

RECOMMENDED PLAN

The recommended plan includes consolidating the number and types of land use zones within the STA. As an outcome, there will be more clarity and consistency in the types of development that will occur within the STA, and therefore the City will be more readily able to achieve their goal of a vibrant downtown. Further, the development allowed by the new zoning is of a density and nature consistent with current plans for growth in Downtown; therefore the annual growth factor of 1.6 percent per year that has been applied to the existing traffic volumes yields traffic volumes consistent with the proposed changes in zoning.

Figure 13 shows a schematic of the recommended future lane configurations on ORE 11 from SE 14th Avenue to SW 2nd Avenue. As shown ORE 11 would be converted to a three-lane facility from approximately SE 14th Avenue to SE 8th Avenue. North of SE 8th Avenue ORE 11 would remain a four-lane facility.

2004 Traffic Operations

Figures 14 and 15 show the forecast existing conditions a.m. and p.m. peak hour operating conditions under this plan. As shown all of the intersections will operate according to ODOT HDM standards for a STA. *See Appendix G.*

Figures 16 and 17 depict the forecast 2025 a.m. and p.m. peak hour traffic operating conditions assuming implementation of the recommended plan. In the future, with this plan implemented, it is forecast that all intersections will operate according to HDM standards. The intersection of SW 8th Avenue/ORE 11 has been modeled assuming ORE 11 is designed allowing for two-stage gap acceptance. *See Appendix H.*

Parking Conditions

The recommended plan maintains most on-street parking on ORE 11. Some parking spaces will be eliminated with construction of curb extensions. Currently there is ample parking in the study area. At this time, the City should not plan any change in parking management. As redevelopment occurs, City Staff should monitor on- and off-street parking utilization in Downtown to ensure that parking management policies are not required.

In the event that on-street parking utilization increases and exceeds 85-percent, parking management policies should be established to provide additional supply. While a detailed parking supply, demand and utilization analysis will be required if this occurs, possible parking management strategies include:

- Initiating and enforcing different parking duration limits in different areas of Downtown;
- Installing parking meters;
- Initiating neighborhood parking permit programs;
- Working with property owners to make private parking available to the public;
- Developing a city owned at-grade parking area.

Access Management

Under existing conditions, the spacing of access points to and from ORE 11 within the STA largely does not meet ODOT STA access spacing standards. As properties along the corridor redevelop, new properties are developed, or the City implements the recommended plan, the City will need to implement access management programs and policies to ultimately comply with ODOT standards. Possible access management strategies include:

- Eliminating multiple access points to one property;
- Implementing one shared access point to two or more properties;
- Modifying zoning requirements to avoid the need for on-site parking or circulation;

- Consolidating multiple properties to single lots for simplified access requirements; or
- Providing development benefits to property owners who eliminate their access point to ORE 11.

Queuing Conditions

Vehicle queuing conditions for the no-build and recommended alternative were analyzed and are summarized in Table 3. As shown in the table under existing conditions, p.m. peak hour vehicle queuing at the unsignalized intersections is limited to one to three vehicles at all locations. PM Peak hour vehicle queuing is longer at ORE 11/SW 2nd Avenue due to the traffic signal. However the access management at the westbound approach to this intersection allows for the vehicle queuing to occur without any other vehicle conflicts.

If the recommended plan were implemented under existing weekday p.m. peak hour traffic volumes, vehicle queuing at the unsignalized intersections with ORE 11 would change only at the ORE 11/8th Avenue intersection. Even at ORE 11/8th Avenue, the queuing increased only from 25 to 50 feet.

Under the forecast 2025 *no-build* p.m. peak hour conditions, queues will be approximately twice the length of queues under existing conditions. However, queues are limited to no more than four cars for all unsignalized intersections. For ORE 11/SW 2nd Ave, PM Peak hour 95th percentile queues of around 200 feet are projected, and this is within the capacity of existing intersection storage.

With the *recommended plan implemented*, forecast 2025 p.m. peak hour vehicle queues will increase somewhat over the no-build case, but remain at or under four cars for all unsignalized intersections in the study area. Further, relative to the no-build conditions it is forecast the recommended plan would increase minor-street queuing by at most two vehicles (ORE 11/SW 7th). Because the recommended plan allows for two-stage gap acceptance at ORE 11/SW 8th Avenue, the forecast vehicle queue at this location would decrease relative to the forecast *no-build* condition. *The results of the analysis are included in Appendix I.*

Table 3 Vehicle Queuing Conditions

	2004 PM, 4-lanes		2004 PM Recommended Plan		2025 PM, 4-lanes		2025 PM Recommended Plan	
	Critical Minor Street Movement	Queue Length ¹	Critical Minor Street Movement	Queue Length	Critical Minor Street Movement	Queue Length	Critical Minor Street Movement	Queue Length
ORE 11/ SW 14th Ave.	WB RT	50	WB Shared	50	WB RT	100	WB Shared	100
ORE 11/ SW 12th Ave.	EB Shared	25	EB Shared	25	EB Shared	50	EB Shared	75
ORE 11/ SW 10th Ave.	EB Shared	25	EB Shared	50	EB Shared	75	EB Shared	100
ORE 11/ SW 9th Ave.	WB Shared	25	WB Shared	25	EB Shared	25	EB Shared	50
ORE 11/ SW 8th Ave.	EB Shared	50	EB Shared	50	EB Shared	100	EB Shared	50
ORE 11/ SW 7th Ave.	EB Shared	25	EB Shared	25	EB Shared	50	EB Shared	100
ORE 11/ SW 4th Ave.	WB Shared	25	WB Shared	25	EB Shared	25	EB Shared	25
ORE 11/ SW 2nd Ave.	WB Shared	150	WB LT	150	WB Shared	200	WB LT	200

¹ Queue lengths shown are in feet, and represent the 95th percentile length. 25 feet equals one car length.

Highway Segment Designations and Objectives (1999 Oregon Highway Plan, 2004 amended Policy 1B)

As Milton-Freewater proceeds with implementing the STA on ORE 11 between SW 14th and SW 2nd, the following material from the 1999 Oregon Highway Plan, 2004 amended Policy 1B should serve as a guide:

A Special Transportation Area (STA) is a designated district of compact development located on a state highway within an urban growth boundary in which the need for appropriate local access outweighs the considerations of highway mobility except on designated Freight Highways where through highway mobility has greater importance.

While traffic moves through an STA and automobiles may play an important role in accessing an STA, convenience of movement within an STA is focused upon pedestrian, bicycle and transit modes. STAs look like traditional "Main Streets" and are generally located on both sides of a state highway. The primary objective of an STA is to provide access to and circulation amongst community activities, businesses and residences and to accommodate pedestrian, bicycle and transit movement along and across the highway. Direct street connections and shared on-street parking are encouraged. Local auto, pedestrian, bicycle and transit

movements to the area are generally as important as the through movement of traffic. Traffic speeds are slow, generally 25 miles per hour or less.

Location. STAs can be located within urban growth boundaries on District, Regional and Statewide Highways but not on Interstates or Expressways. An existing central business or commercial district in an unincorporated community as defined by OAR 660-022-0010(10) that meets the definition of an STA may also be classified as an STA. Larger communities may have more than one STA.

While STAs may include some properties that are currently developed for auto-dependent uses (e.g., drive thru restaurants, gas stations, car washes), areas where the predominant land use pattern is auto-dependent uses are generally not appropriate for STA designation. STAs that include properties developed for auto-dependent uses should include planning and zoning that provides for redevelopment of the properties over time to uses consistent with STA implementation.

Planning and Development Guidance for STAs. STAs should be planned and developed to reflect the following kinds of characteristics:

- Buildings spaced close together and located adjacent to the street with little or no setback;
- Sidewalks with ample width located adjacent to the highway and the buildings;
- People who arrive by car or transit find it convenient to walk from place to place within the area;
- On-street parking, structured parking, or shared, general purpose parking lots which are located behind or to the side of buildings;
- Streets designed with a pedestrian orientation for the ease of crossing by pedestrians;
- Public road connections that correspond to the existing city block; private driveways directly accessing the highway are discouraged;
- Adjacent land uses that provide for compact, mixed-use development with buildings oriented to the street;
- A well-developed parallel and interconnected street network to facilitate local automobile, bicycle, transit and pedestrian circulation except where topography severely constrains the potential for street connections;
- Speeds that typically do not exceed 25 miles per hour;
- Plans and provisions for infill and redevelopment;

- Provision for well-developed transit stops including van/bus stops, bicycle and pedestrian facilities, and including street amenities that support these modes.

The Oregon Highway Plan recognizes that a significant amount of coordination and collaboration will occur between ODOT and Milton-Freewater in order to implement and achieve the goals of the STA.

General Circulation

As the recommended plan is further refined, and detailed design/engineering begins, the following list of items should be considered as part of this process:

- Large Vehicle Access To Businesses In Downtown – Truck circulation to/from and within Downtown will be a consideration as detailed design begins. Considerations will include turning radii to and from businesses on ORE 11 and turning radii at intersections within the STA. The ODOT Highway Design Manual provides guidance on the standards for these features. The goal of the STA is to develop main street type access in downtown. This includes limiting the number of direct driveways onto and off-of ORE 11 and designing low speed turns at intersections. The design will not preclude large vehicles circulating within downtown. At corners, large vehicles may have to travel into the opposing lane on the minor street to complete the turn, or special design exceptions can be achieved with ODOT. Large vehicle direct access onto individual properties will become more constrained as downtown redevelops with STA compatible land uses; however designs can be developed to maintain access to specific properties.
- Travel Lane Widths – Under the proposed plan, there is ample space within the current right-of-way to maintain 12-foot travel lanes within the STA. A 12-foot travel lane is consistent with ORE 11 lane widths outside the STA. Therefore large vehicles accommodated on ORE 11 outside of Downtown will also be accommodated through Downtown. In the event that overload or oversize vehicles are traveling through Milton-Freewater standard ODOT requirements would have to be fulfilled.
- Loading Zones – Loading zones within the STA will also be identified as part of the detailed design. The location and number of the loading zones will be dependent on the distribution of businesses, and parking demand. The loading zone spaces can be permanent loading zone spaces, or they can be regular parking spaces during peak parking periods, and loading zone spaces during off-periods. As Downtown becomes more popular, it may be necessary to limit loading to specific off-peak hours (e.g. early in the morning).

Note this is an incomplete list of items that will be considered as part of the detailed design process. It has been presented in regards to specific questions raised as part of the project.

We trust that this report adequately addresses the transportation related questions for updating the City's Transportation System Plan and adopting the Special Transportation Area for ORE 11 from SW 14th to SW 2nd Avenue in Milton-Freewater. Should there be any additional questions, please contact us at 503-228-5230.

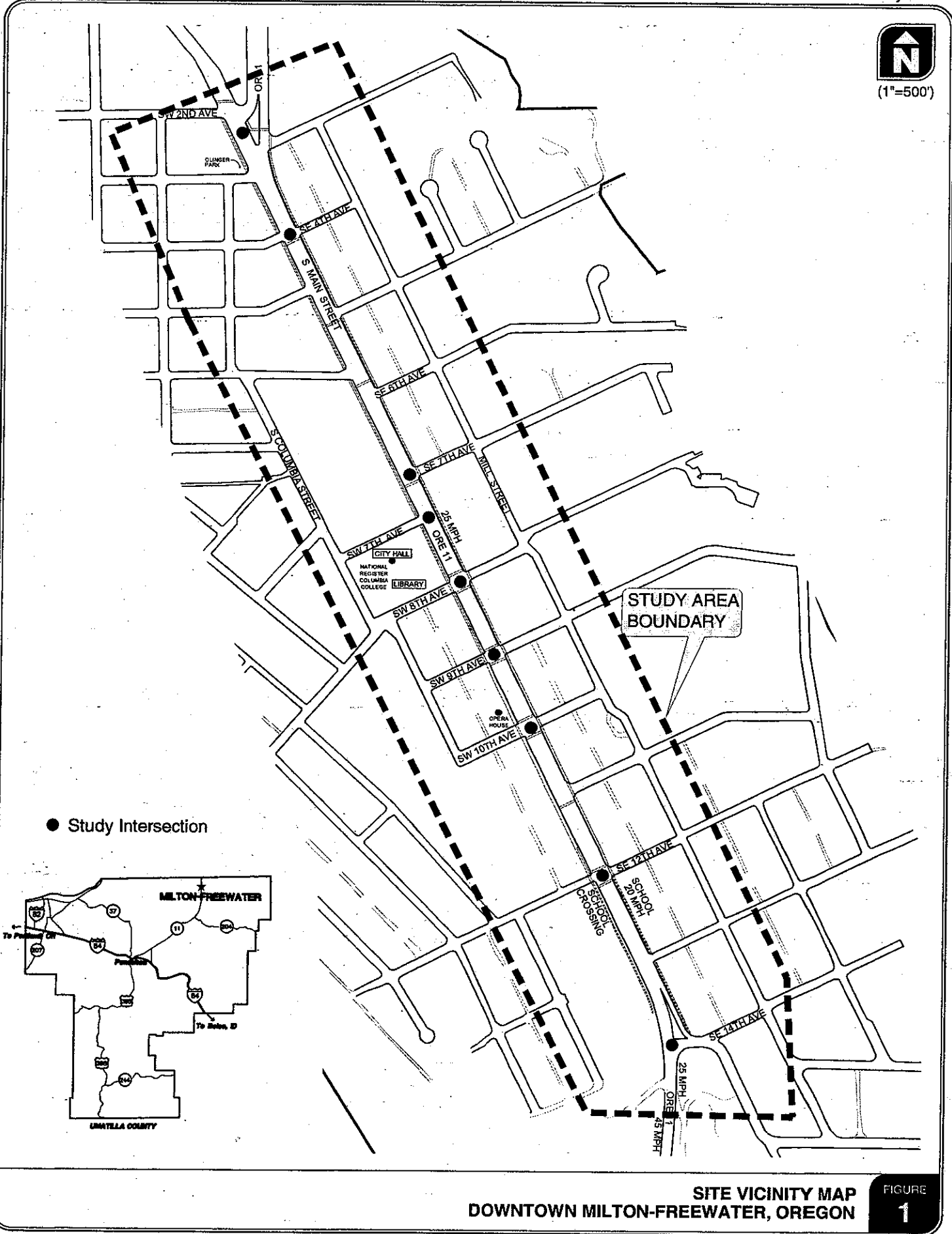

**SITE VICINITY MAP
DOWNTOWN MILTON-FREEWATER, OREGON**

**FIGURE
1**

H:\profile\67431\dwgs\figs\67431\FIGS.dwg Jun 02, 2005 - 5:11pm - jpark Layout Tab: FIG 01



(NO SCALE)

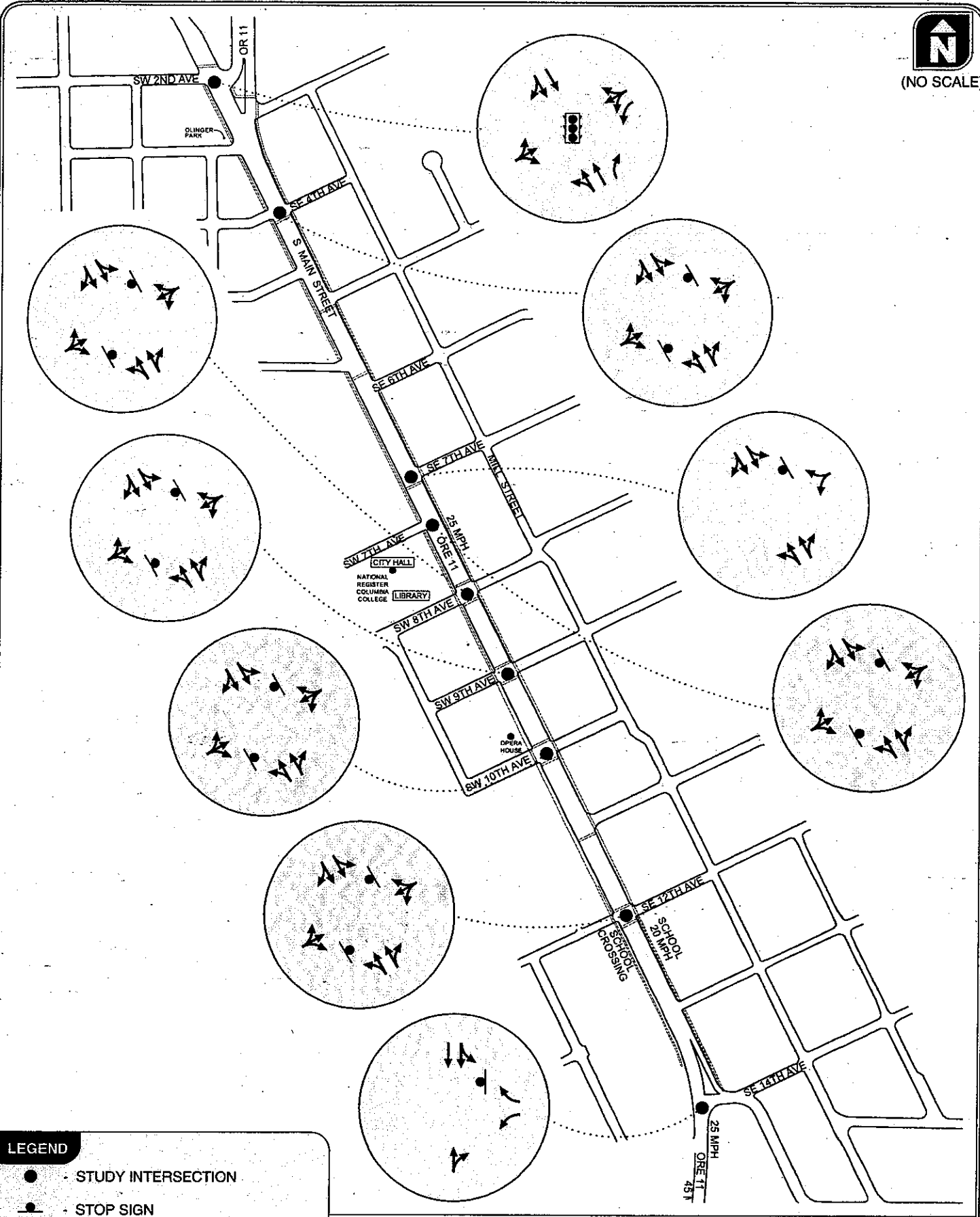

EXISTING FACILITIES AND LANE CONFIGURATION MAP MILTON-FREEWATER, OREGON

FIGURE 2

H:\profile\16743\dwg\figs\16743\FIGS.dwg Jun 02, 2005 - 5:11pm - ipanks Layout Tab: FIG 02

LEGEND

- - STUDY INTERSECTION
- - STOP SIGN
- 🚦 - TRAFFIC SIGNAL

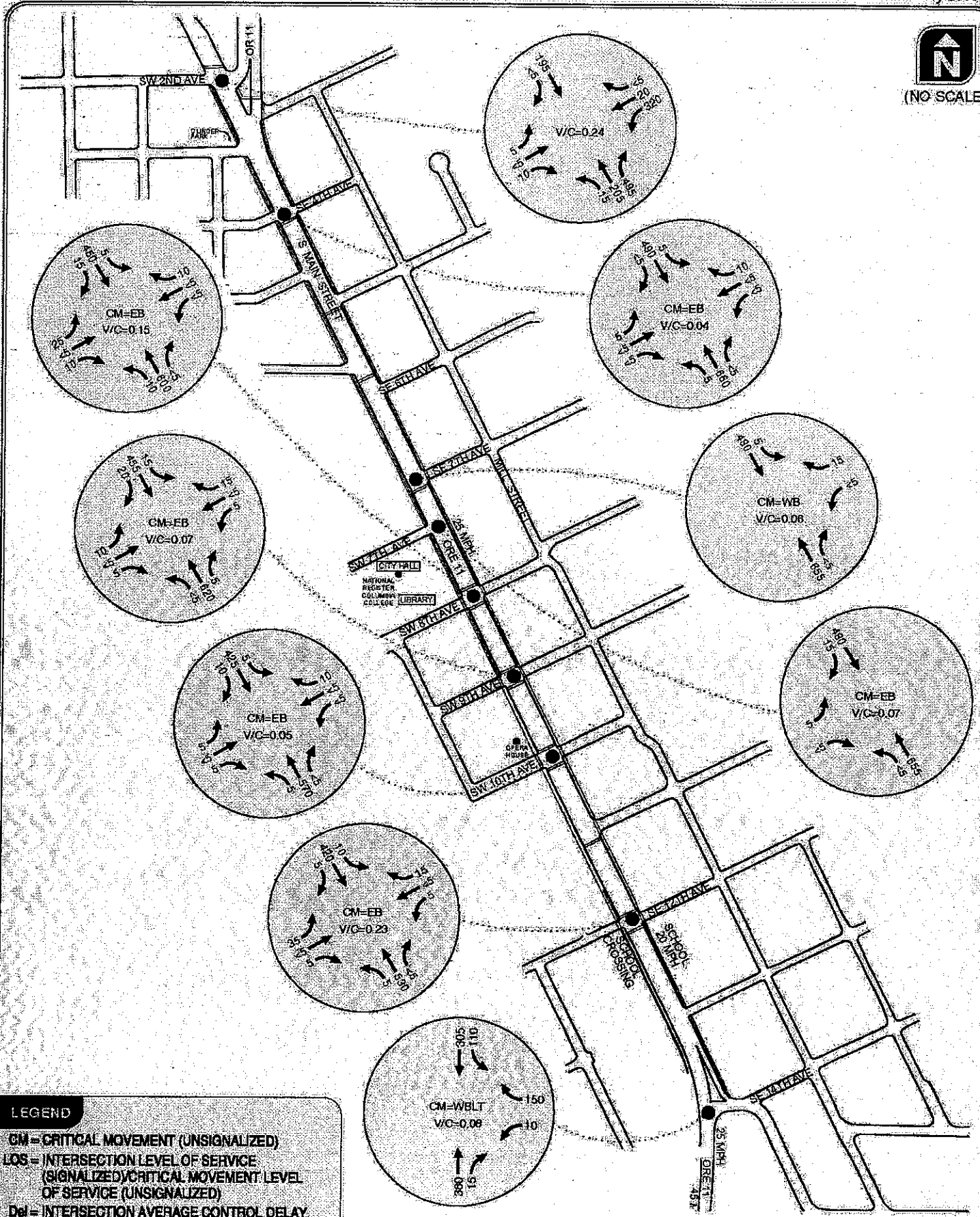

LEGEND

- CM = CRITICAL MOVEMENT (UNSIGNALIZED)
- LOS = INTERSECTION LEVEL OF SERVICE (SIGNALIZED)/CRITICAL MOVEMENT LEVEL OF SERVICE (UNSIGNALIZED)
- Del = INTERSECTION AVERAGE CONTROL DELAY (SIGNALIZED)/CRITICAL MOVEMENT CONTROL DELAY (UNSIGNALIZED)
- V/C = CRITICAL VOLUME-TO-CAPACITY RATIO

2004 EXISTING TRAFFIC CONDITIONS
WEEKDAY AM PEAK HOUR
MILTON-FREEWATER, OREGON

FIGURE
3

H:\profile\B\A\3\ch\fig16743763\S.dwg Jun 09 2005 9:42am open Layer: Top FIG.03

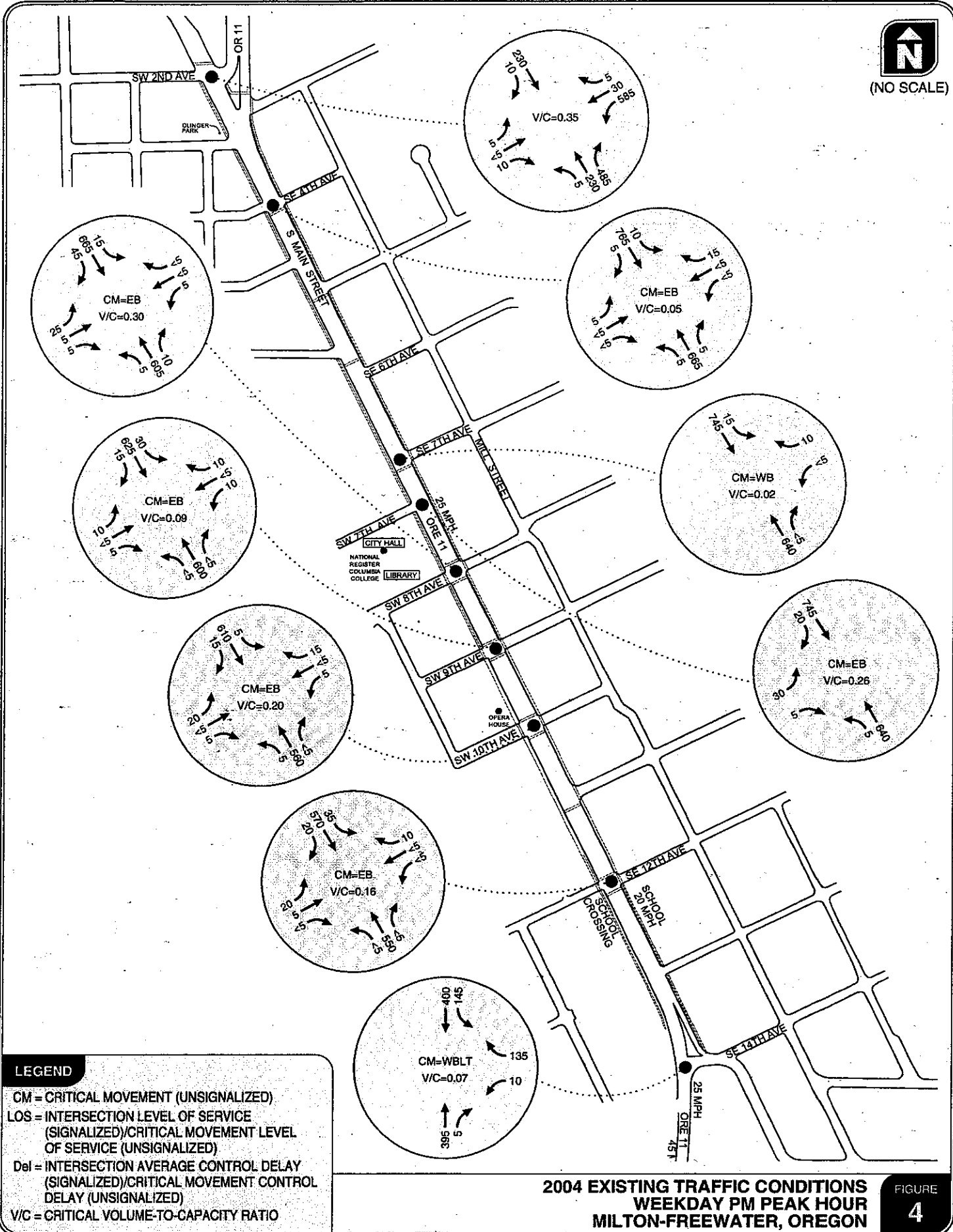

H:\profile\6743\dwgs\figs\6743\FIGSS.dwg Jun 03, 2005 - 9:42am - open Layout Tab: FIG 04

LEGEND



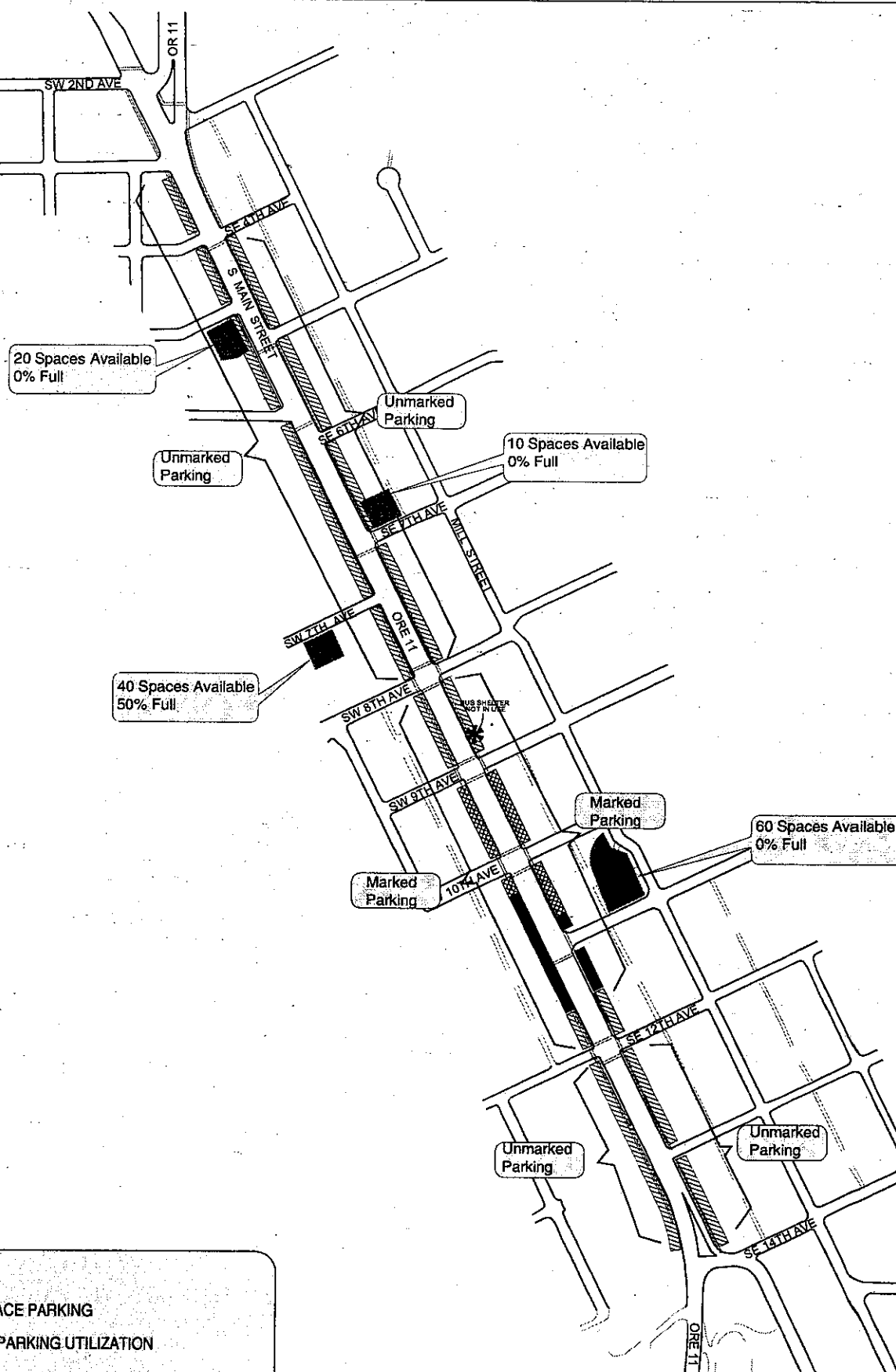

CM = CRITICAL MOVEMENT (UNSIGNALIZED)
 LOS = INTERSECTION LEVEL OF SERVICE (SIGNALIZED)/CRITICAL MOVEMENT LEVEL OF SERVICE (UNSIGNALIZED)
 Del = INTERSECTION AVERAGE CONTROL DELAY (SIGNALIZED)/CRITICAL MOVEMENT CONTROL DELAY (UNSIGNALIZED)
 V/C = CRITICAL VOLUME-TO-CAPACITY RATIO

**2004 EXISTING TRAFFIC CONDITIONS
 WEEKDAY PM PEAK HOUR
 MILTON-FREEWATER, OREGON**

**FIGURE
 4**



LEGEND

-  - SURFACE PARKING
-  - LOW PARKING UTILIZATION
-  - MEDIUM PARKING UTILIZATION
-  - HIGH PARKING UTILIZATION

PARKING INVENTORY AND UTILIZATION

MILTON-FREEWATER, OREGON

FIGURE 5

H:\profile\16743\dwgs\figs\16743FIG5.dwg Jun 02, 2005 - 5:11pm - jpark Layout Tab: FIG 05



(NO SCALE)

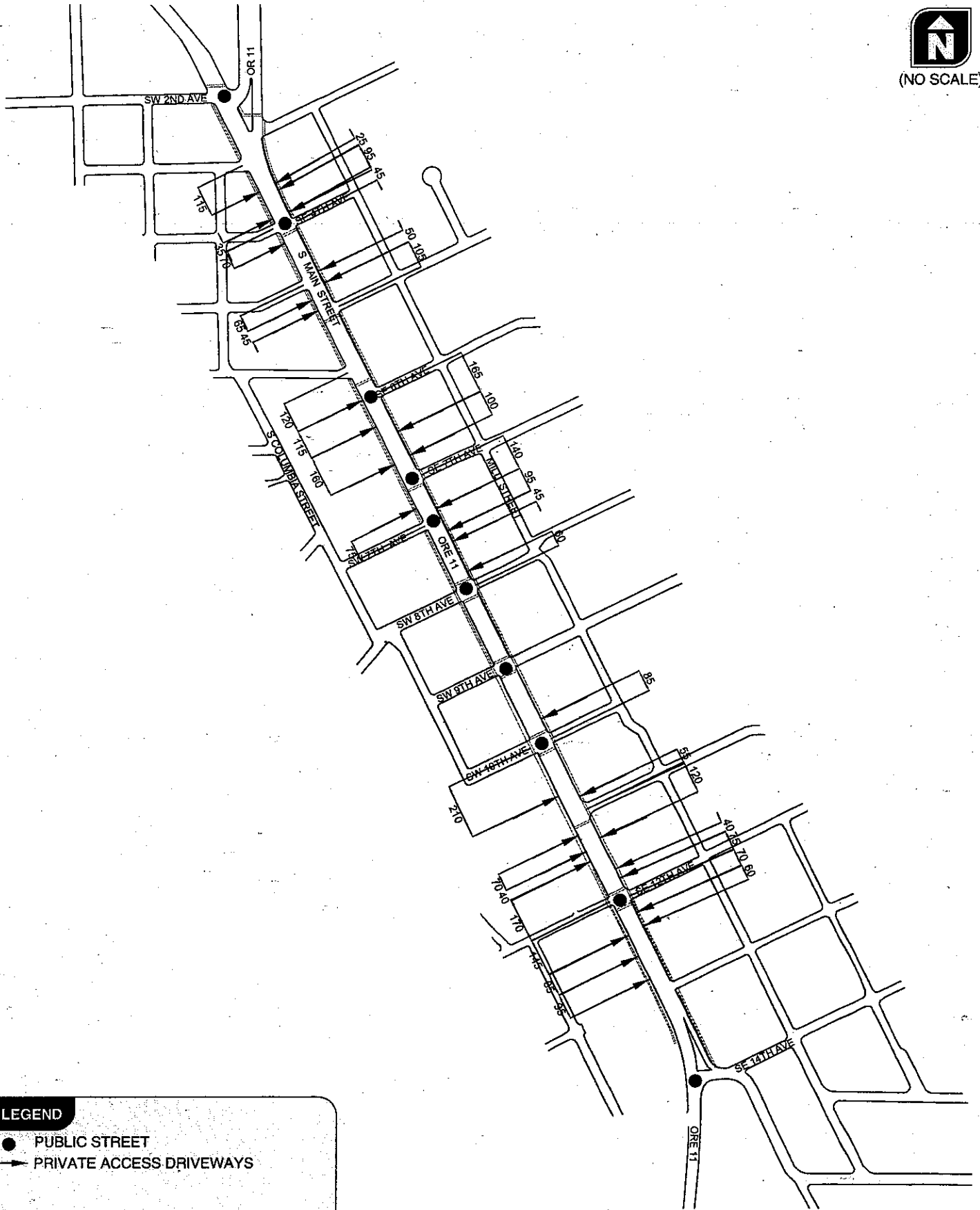

LEGEND

- PUBLIC STREET
- ➔ PRIVATE ACCESS DRIVEWAYS

**EXISTING ACCESS SPACING
MILTON-FREEWATER, OREGON**

**FIGURE
6**

H:\profile16749\dwg\figs\16749FIGS.dwg Jun 02, 2005 5:11pm - jpark Layout Tab: FIG 06

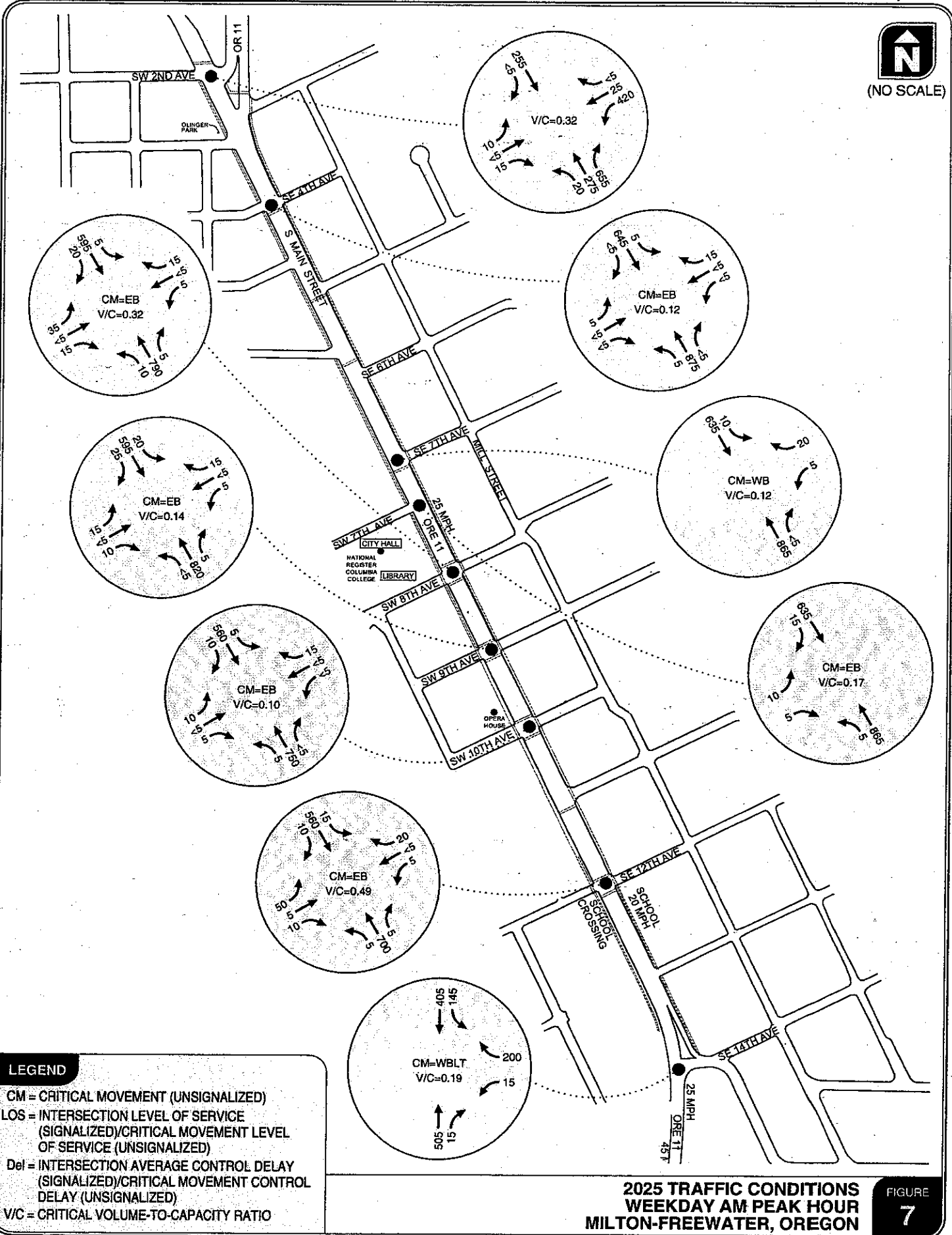

H:\profile\6749\dwgs\figs\6749\FIGS.dwg Jun 03, 2005 - 9:42am - open Layout Tab: FIG 07

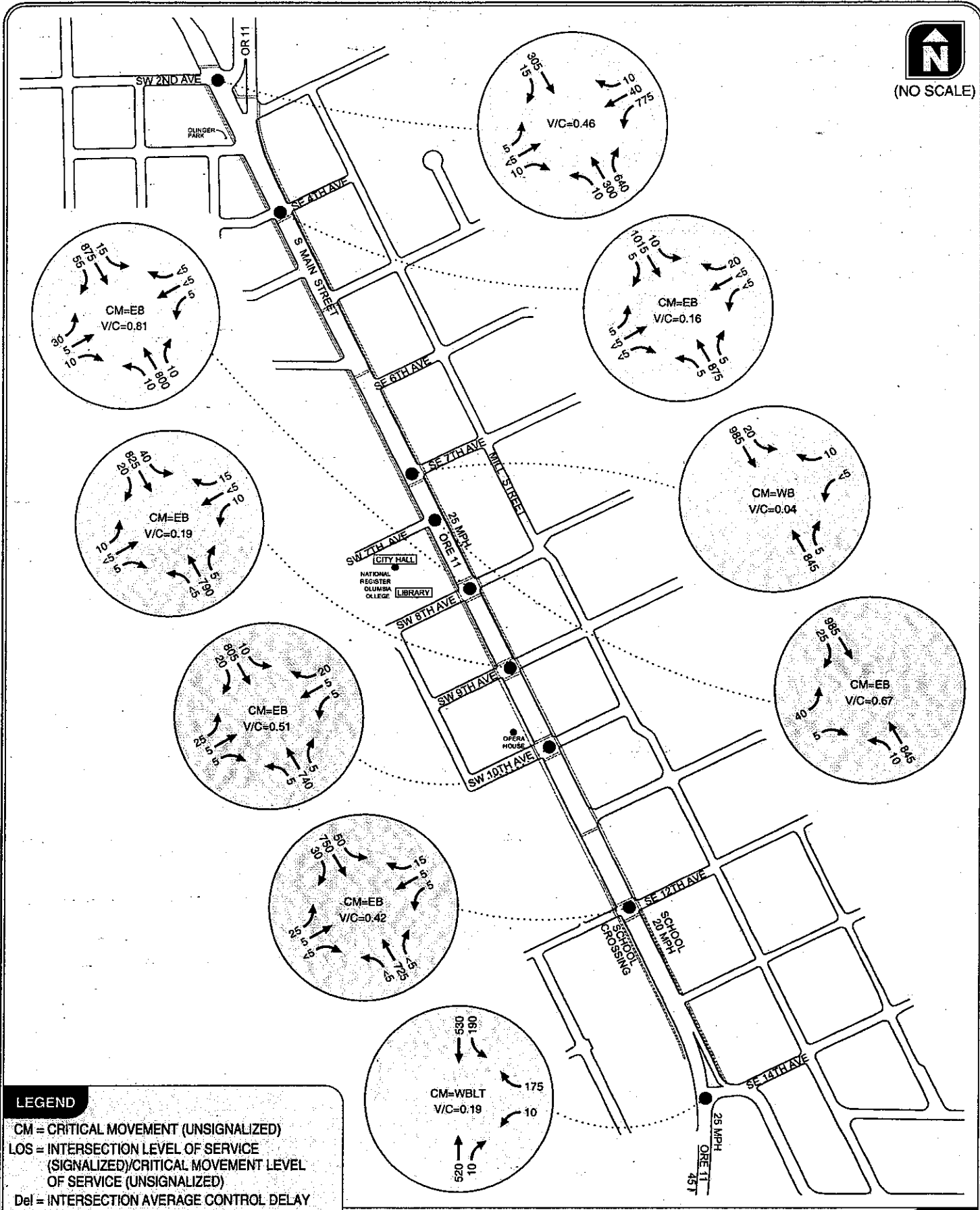

H:\profile\6743\dwg\figs\6743\FIGS.dwg Jun 03, 2005 - 9:42am - open Layout Tab: FIG 08

LEGEND

CM = CRITICAL MOVEMENT (UNSIGNALIZED)
 LOS = INTERSECTION LEVEL OF SERVICE (SIGNALIZED)/CRITICAL MOVEMENT LEVEL OF SERVICE (UNSIGNALIZED)
 Del = INTERSECTION AVERAGE CONTROL DELAY (SIGNALIZED)/CRITICAL MOVEMENT CONTROL DELAY (UNSIGNALIZED)
 V/C = CRITICAL VOLUME-TO-CAPACITY RATIO

**2025 TRAFFIC CONDITIONS
 WEEKDAY PM PEAK HOUR
 MILTON-FREEWATER, OREGON** FIGURE 8

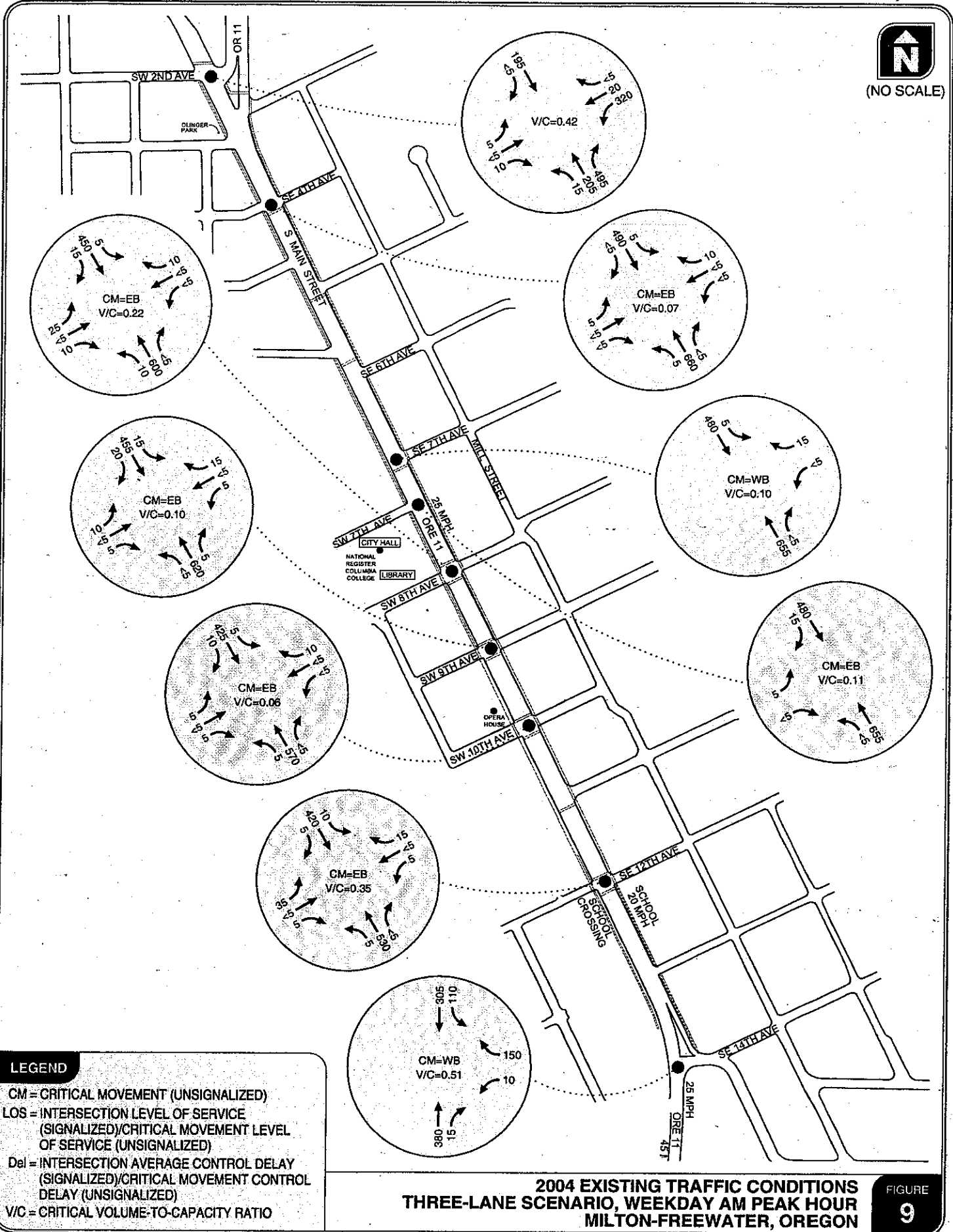

H:\profile\6743\dwg\figs\6743\FIGS.dwg Jun 03, 2005 - 9:42am - open Layout Tab: FIG 9

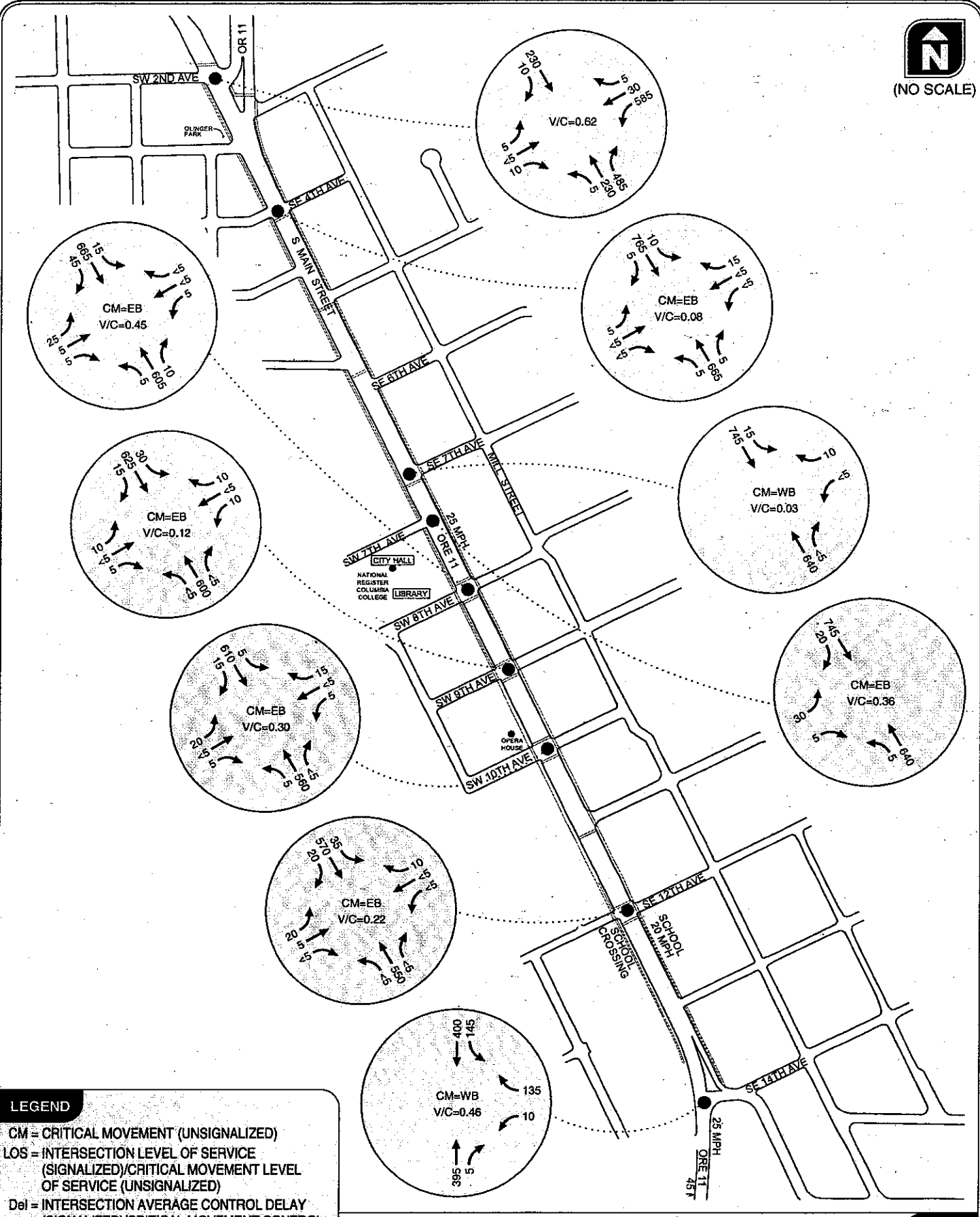

H:\profile\6743\dwgs\figs\16743FIGS.dwg Jun 03, 2005 - 9:50am - open Layout Tab: FIG 10

LEGEND

- CM = CRITICAL MOVEMENT (UNSIGNALIZED)
- LOS = INTERSECTION LEVEL OF SERVICE (SIGNALIZED)/CRITICAL MOVEMENT LEVEL OF SERVICE (UNSIGNALIZED)
- Del = INTERSECTION AVERAGE CONTROL DELAY (SIGNALIZED)/CRITICAL MOVEMENT CONTROL DELAY (UNSIGNALIZED)
- V/C = CRITICAL VOLUME-TO-CAPACITY RATIO

**2004 EXISTING TRAFFIC CONDITIONS
THREE-LANE SCENARIO, WEEKDAY PM PEAK HOUR
MILTON-FREEWATER, OREGON**

**FIGURE
10**

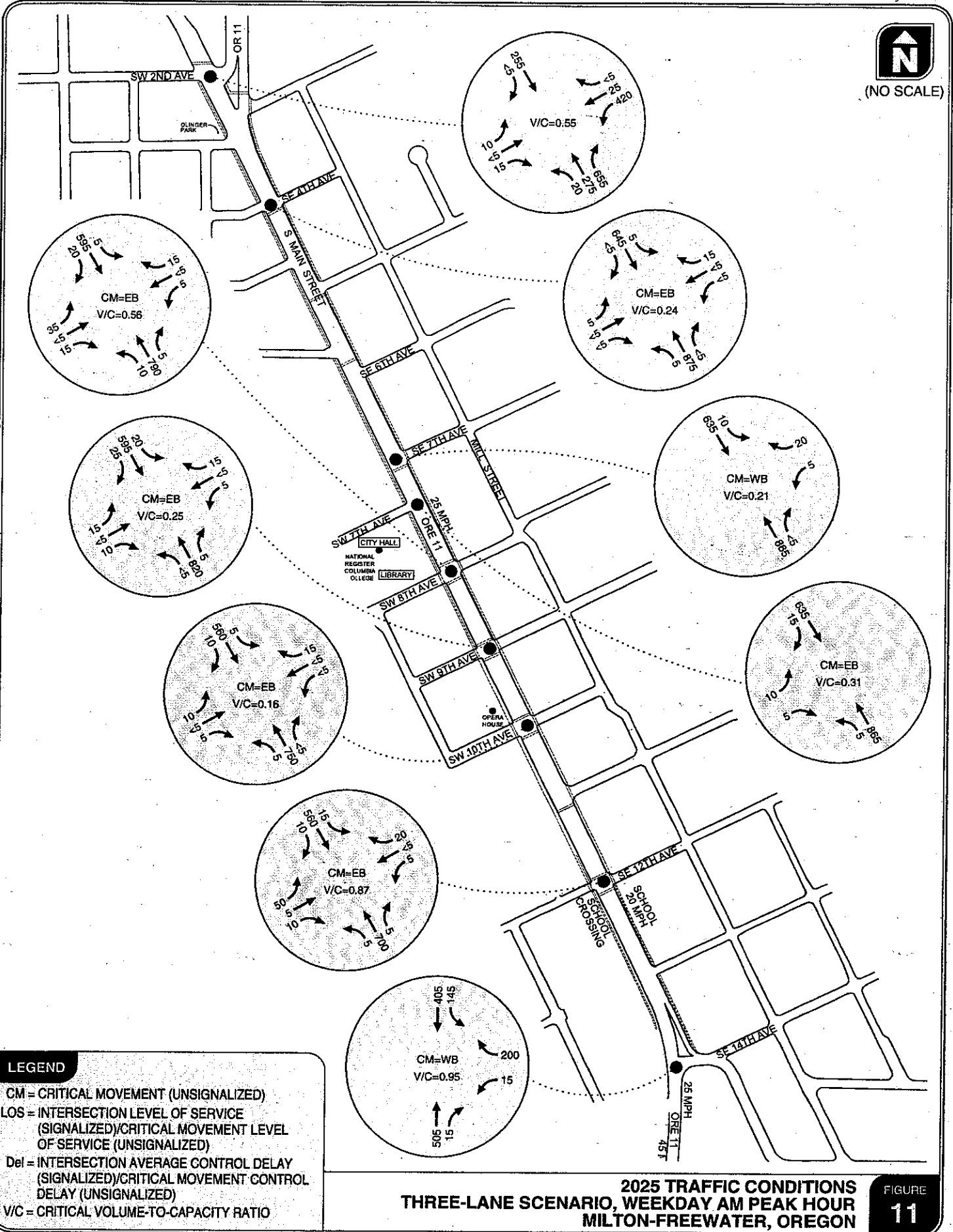

H:\profile16743\dwg\figs16743\FIGS.dwg Jun 03, 2005 - 9:42am - open Layout Tab: FIG 11

LEGEND

CM = CRITICAL MOVEMENT (UNSIGNALIZED)
 LOS = INTERSECTION LEVEL OF SERVICE (SIGNALIZED)/CRITICAL MOVEMENT LEVEL OF SERVICE (UNSIGNALIZED)
 Del = INTERSECTION AVERAGE CONTROL DELAY (SIGNALIZED)/CRITICAL MOVEMENT CONTROL DELAY (UNSIGNALIZED)
 V/C = CRITICAL VOLUME-TO-CAPACITY RATIO

**2025 TRAFFIC CONDITIONS
 THREE-LANE SCENARIO, WEEKDAY AM PEAK HOUR
 MILTON-FREEWATER, OREGON**

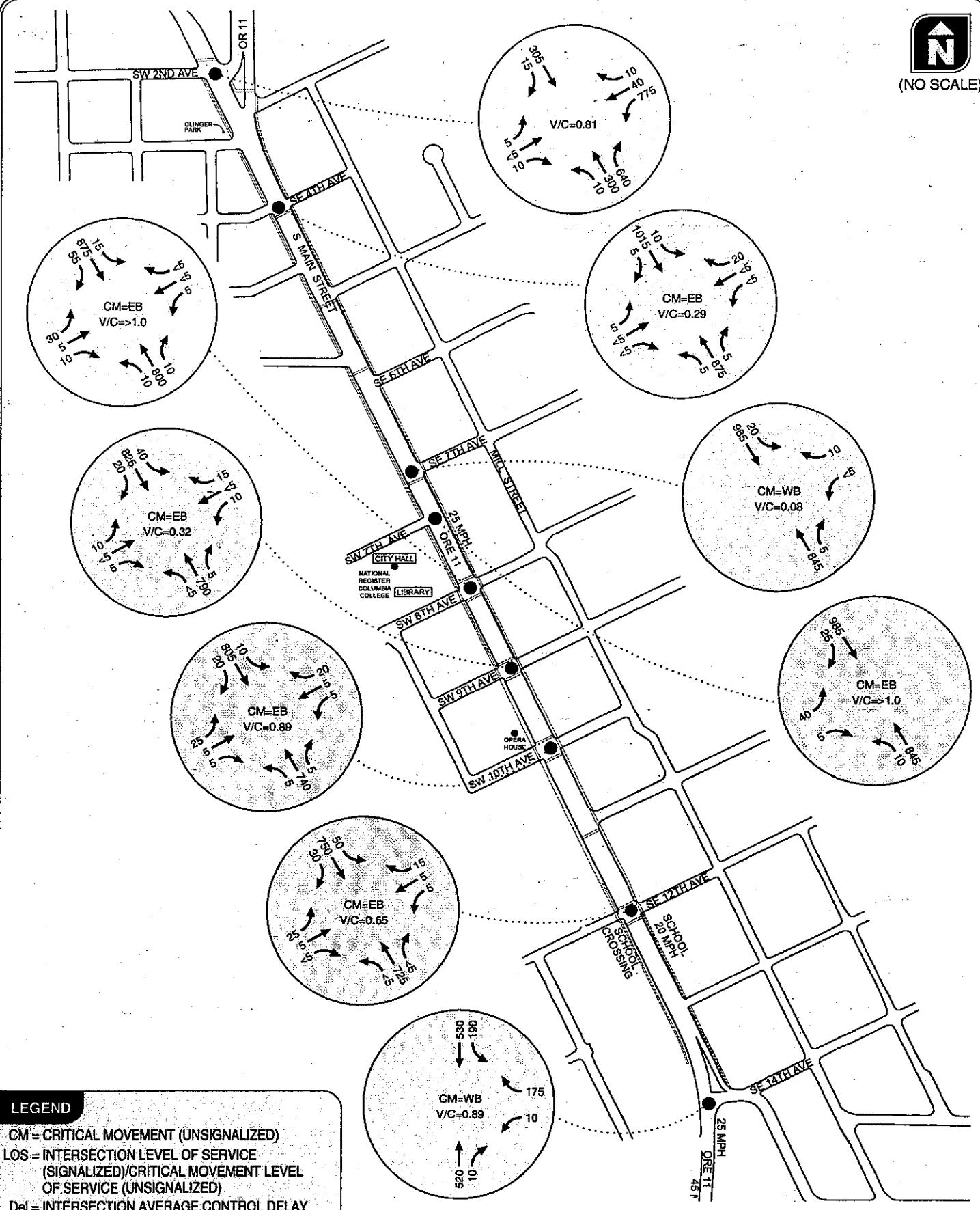

H:\projfile\67431\dws\figs\67431\FIGS.dwg Jun 03, 2005 - 9:42am - open Layout Tab: FIG 12

LEGEND



- CM = CRITICAL MOVEMENT (UNSIGNALIZED)
- LOS = INTERSECTION LEVEL OF SERVICE (SIGNALIZED)/CRITICAL MOVEMENT LEVEL OF SERVICE (UNSIGNALIZED)
- Del = INTERSECTION AVERAGE CONTROL DELAY (SIGNALIZED)/CRITICAL MOVEMENT CONTROL DELAY (UNSIGNALIZED)
- V/C = CRITICAL VOLUME-TO-CAPACITY RATIO

**2025 TRAFFIC CONDITIONS
THREE-LANE SCENARIO, WEEKDAY PM PEAK HOUR
MILTON-FREEWATER, OREGON**

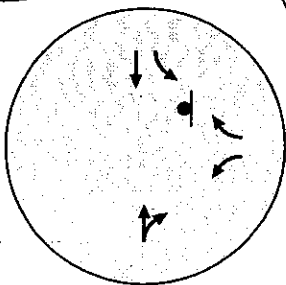
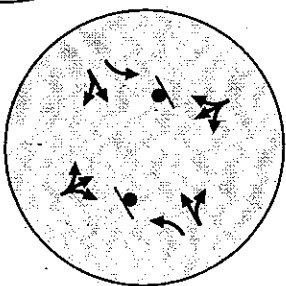
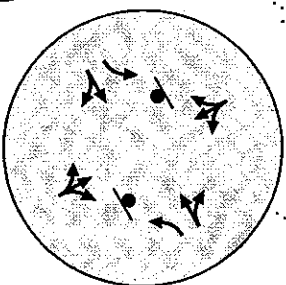
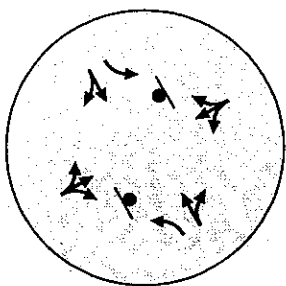
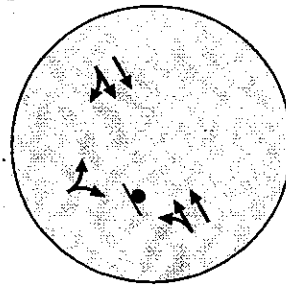
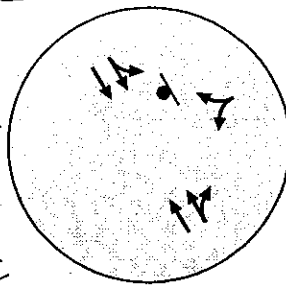
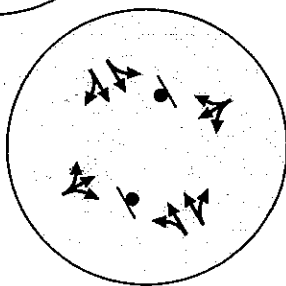
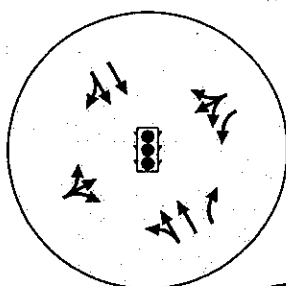
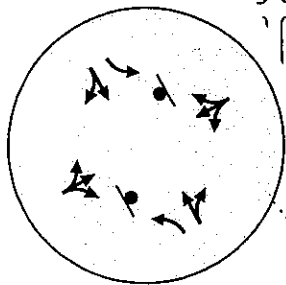
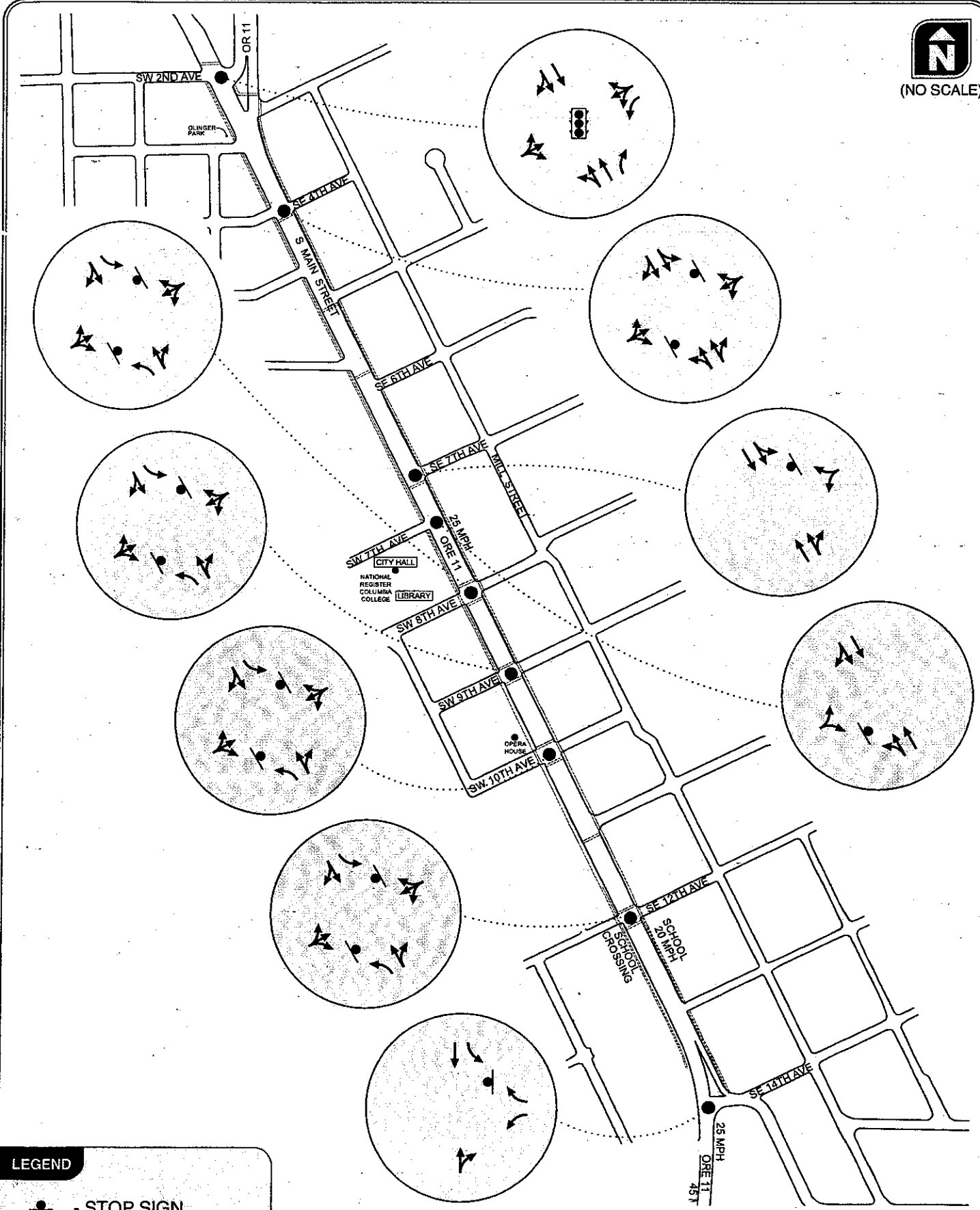
FIGURE
12



LEGEND

-  - STOP SIGN
-  - TRAFFIC SIGNAL

**RECOMMENDED SCENARIO
LANE CONFIGURATION
MILTON-FREEWATER, OREGON**

**FIGURE
13**

H:\profile\6743\dwgs\figs\6743\FIG13.dwg Jun 03, 2005 - 9:42am - open Layout Tab: FIG 13

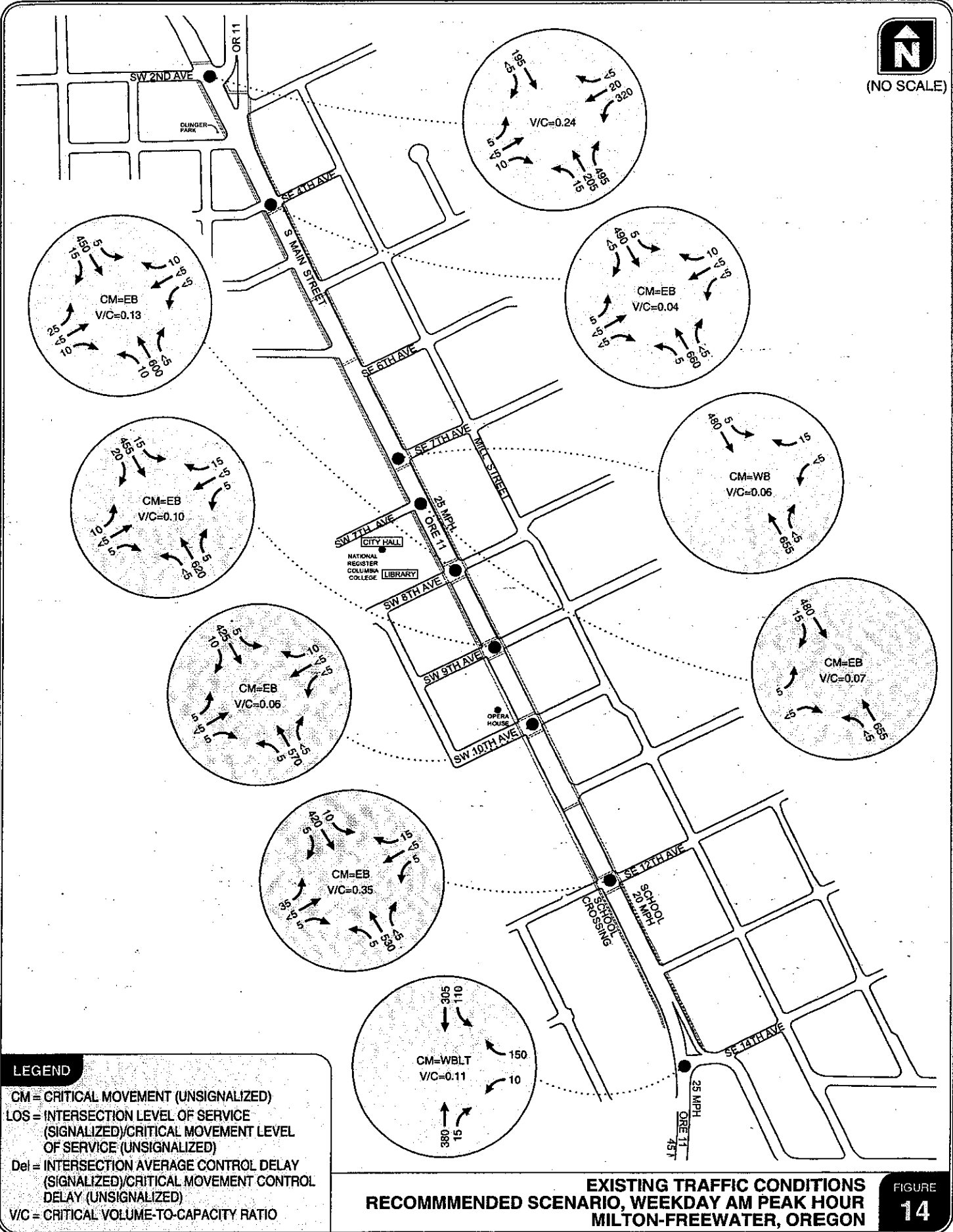

H:\profiles\16743\dwg\figs\16743\FIGS.dwg Jun 03, 2005 - 9:42am - open Layout Tab: FIG 14

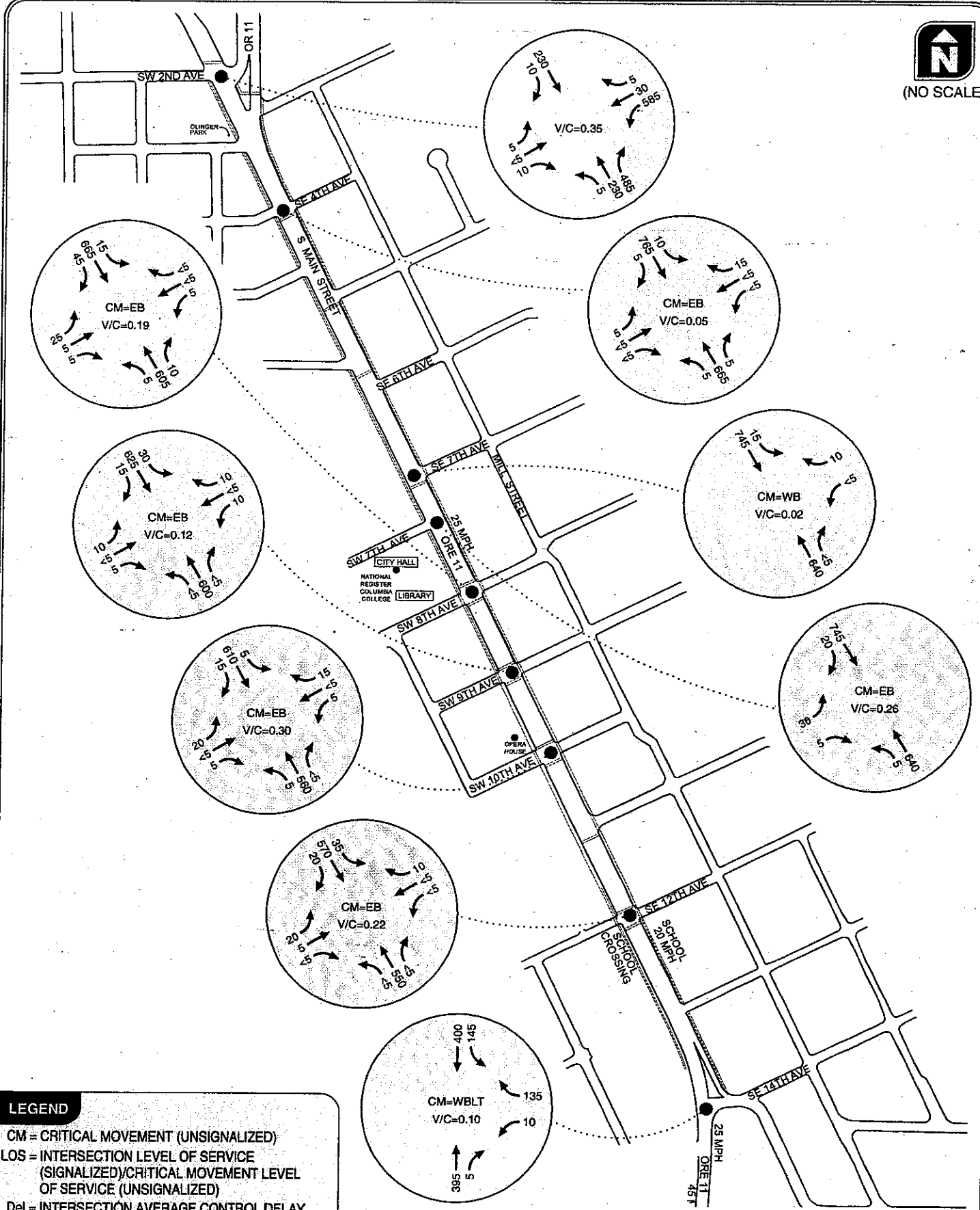

LEGEND

CM = CRITICAL MOVEMENT (UNSIGNALIZED)
 LOS = INTERSECTION LEVEL OF SERVICE (SIGNALIZED)/CRITICAL MOVEMENT LEVEL OF SERVICE (UNSIGNALIZED)
 Del = INTERSECTION AVERAGE CONTROL DELAY (SIGNALIZED)/CRITICAL MOVEMENT CONTROL DELAY (UNSIGNALIZED)
 V/C = CRITICAL VOLUME-TO-CAPACITY RATIO

**EXISTING TRAFFIC CONDITIONS
 RECOMMENDED SCENARIO, WEEKDAY PM PEAK HOUR
 MILTON-FREEWATER, OREGON**

FIGURE
15

H:\profile\6743\dwgs\figs\6743\FIGS.dwg Jun 03, 2005 - 9:42am - open Layout Tab: FIG 15

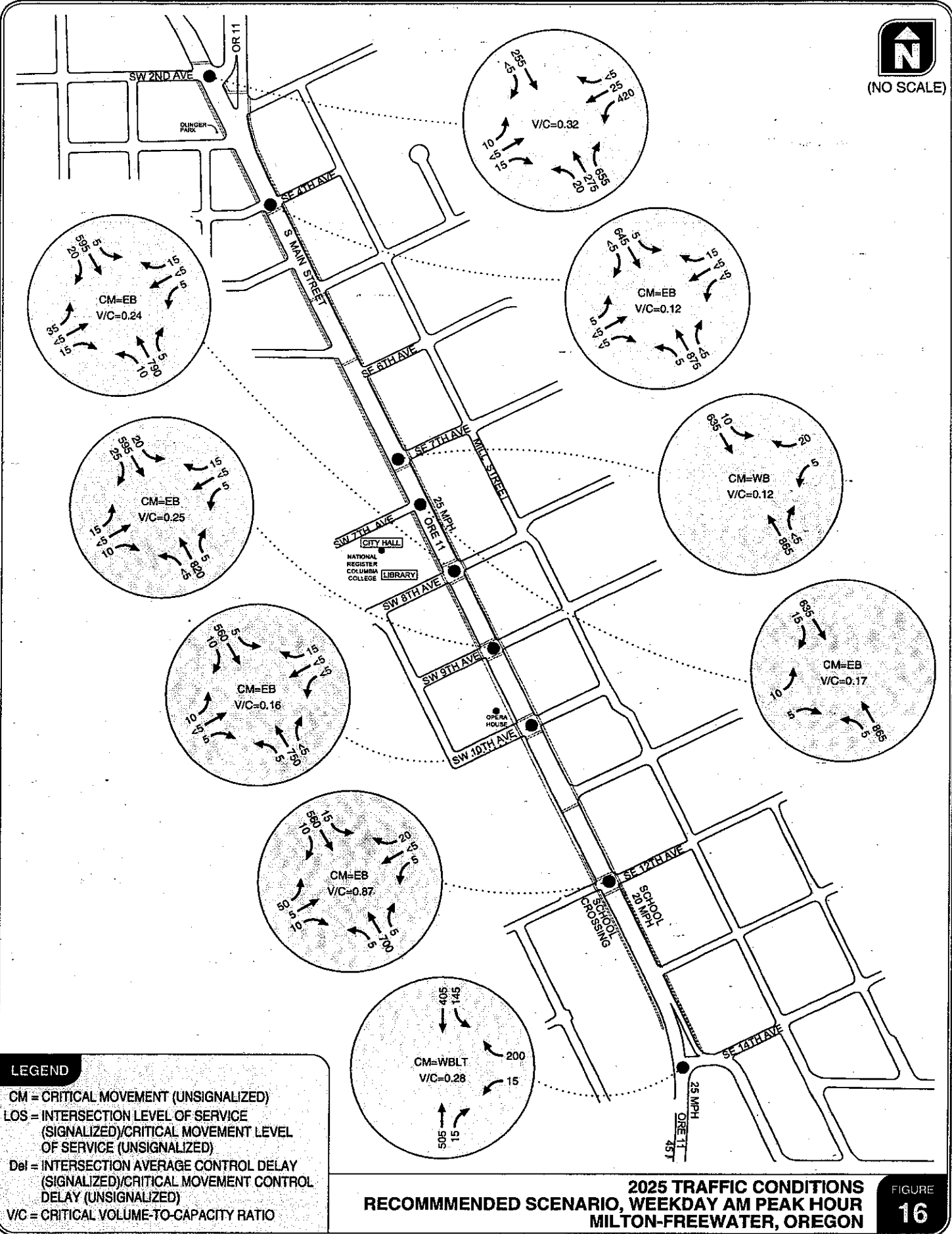

H:\projfile\6743\dwgs\figs\6743FIGS.dwg Jun 03, 2005 - 9:42am - open Layout Tab: FIG 16

LEGEND

- CM = CRITICAL MOVEMENT (UNSIGNALIZED)
- LOS = INTERSECTION LEVEL OF SERVICE (SIGNALIZED)/CRITICAL MOVEMENT LEVEL OF SERVICE (UNSIGNALIZED)
- Del = INTERSECTION AVERAGE CONTROL DELAY (SIGNALIZED)/CRITICAL MOVEMENT CONTROL DELAY (UNSIGNALIZED)
- V/C = CRITICAL VOLUME-TO-CAPACITY RATIO

**2025 TRAFFIC CONDITIONS
RECOMMENDED SCENARIO, WEEKDAY AM PEAK HOUR
MILTON-FREEWATER, OREGON**

**FIGURE
16**

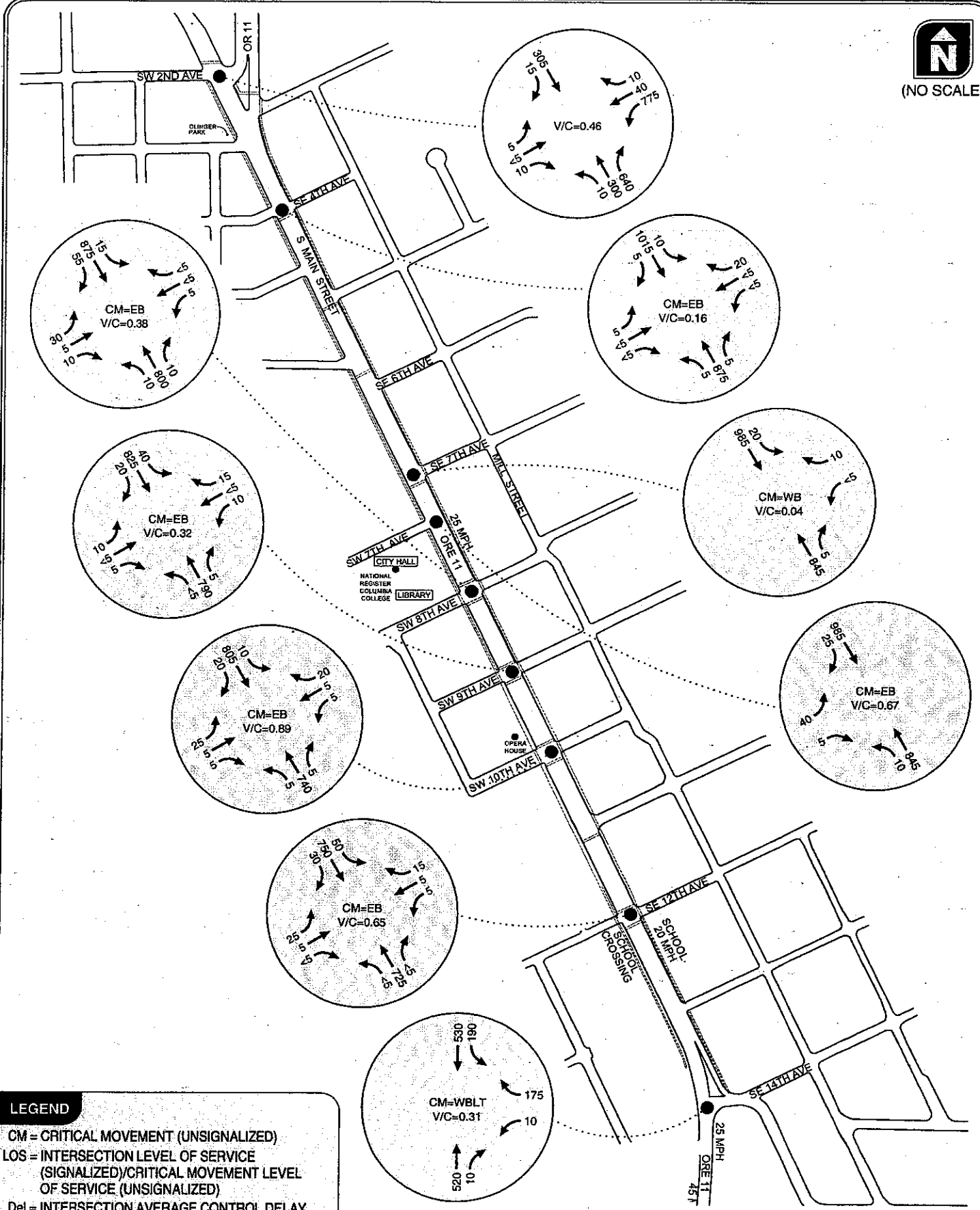

LEGEND

CM = CRITICAL MOVEMENT (UNSIGNALIZED)
 LOS = INTERSECTION LEVEL OF SERVICE (SIGNALIZED)/CRITICAL MOVEMENT LEVEL OF SERVICE (UNSIGNALIZED)
 Del = INTERSECTION AVERAGE CONTROL DELAY (SIGNALIZED)/CRITICAL MOVEMENT CONTROL DELAY (UNSIGNALIZED)
 V/C = CRITICAL VOLUME-TO-CAPACITY RATIO

**2025 TRAFFIC CONDITIONS
 RECOMMENDED SCENARIO, WEEKDAY PM PEAK HOUR
 MILTON-FREEWATER, OREGON**

**FIGURE
 17**

H:\profile\6743\dwgs\figs\6743\FIGS.dwg Jun 03, 2005 - 9:42am - open Layout Tab: FIG 17

Appendix A

Traffic Count Data

OR11at14th_Reduced.xls

TIME	SB			WB			NB			EB			Total	Hour Total	PHF
	RT	TH	LT	RT	TH	LT	RT	TH	LT	RT	TH	LT			
07:00-07:15A		67	28	16		1	1	88					201	860	0.70
07:15-07:30A		35	9	18		3	0	61					126	872	
07:30-07:45A		71	16	23		4	3	103					220	870	
07:45-08:00A		63	9	70		1	5	165					313	802	
08:00-08:15A		39	53	41		4	5	71					213	589	
08:15-08:30A		31	25	20		1	1	46					124		
08:30-08:45A		40	23	38		2	2	47					152		
08:45-09:00A		26	11	24		0	0	39					100		
AM PH Volumes		208	87	152		12	13	400					872		
04:00-04:15P		68	25	28		1	2	70					194	802	0.71
04:15-04:30P		109	56	35		1	0	80					281	796	
04:30-04:45P		62	25	24		3	3	46					163	652	
04:45-05:00P		61	22	16		3	1	61					164	632	
05:00-05:15P		78	39	12		1	2	56					188	639	
05:15-05:30P		40	22	28		3	0	44					137	610	
05:30-05:45P		61	26	14		1	0	41					143	589	
05:45-06:00P		54	31	16		2	0	68					171	494	
06:00-06:15P		49	45	24		3	1	37					159	406	
06:15-06:30P		45	21	18		2	4	26					116		
06:30-06:45P		12	11	5		1	1	18					48		
06:45-07:00P		26	19	17		1	0	20					83		
PM PH Volumes		300	128	103		8	6	257					802		

OR8 at S 12th Ave_Reduced.xls

TIME	SB			WB			NB			EB			Total	Hour Total	PHF
	RT	TH	LT	RT	TH	LT	RT	TH	LT	RT	TH	LT			
07:00-07:15A	0	61	1	1	0	1	1	55	0	2	0	3	125	616	0.86
07:15-07:30A	2	62	2	4	0	1	0	72	1	2	0	5	151		
07:30-07:45A	2	61	2	2	0	0	0	85	0	1	0	8	161		
07:45-08:00A	1	66	2	3	1	1	1	90	3	1	2	8	179		
AM PH Volumes	5	250	7	10	1	3	2	302	4	6	2	24	616		
04:00-04:15P	2	68	5	0	1	0	0	70	0	0	0	0	146	616	0.73
04:15-04:30P	6	109	4	2	1	1	0	80	0	0	2	6	211		
04:30-04:45P	1	63	9	2	0	1	0	45	0	0	0	1	122		
04:45-05:00P	4	60	5	2	0	0	0	61	1	0	1	3	137		
05:00-05:15P	3	78	1	3	0	0	0	57	0	0	1	1	144		
05:15-05:30P	1	41	2	0	1	1	0	42	0	0	0	2	90		
05:30-05:45P	3	55	1	0	0	0	0	39	0	1	1	0	100		
05:45-06:00P	6	52	1	0	0	0	0	68	1	2	0	7	137		
PM PH Volumes	13	300	23	6	2	2	0	256	1	0	3	10	616		

OR11at10th_Reduced.xls

TIME	SB			WB			NB			EB			Total	Hour Total	PHF
	RT	TH	LT	RT	TH	LT	RT	TH	LT	RT	TH	LT			
07:00-07:15A	0	82	1	0	0	0	0	69	2	2	0	0	156	860	0.70
07:15-07:30A	0	79	1	1	0	0	0	128	2	1	0	0	212	872	
07:30-07:45A	3	62	0	3	0	1	0	81	1	1	0	1	153	870	
07:45-08:00A	3	96	1	4	1	0	0	125	0	2	0	1	233	802	
08:00-08:15A	1	98	2	2	0	0	1	111	2	3	0	3	223	589	
08:15-08:30A	0	72	0	0	0	0	0	87	0	1	0	0	160		
08:30-08:45A	0	43	0	0	0	1	0	112	0	0	0	1	157		
08:45-09:00A	0	54	0	1	0	1	0	101	0	0	0	0	157		
AM PH Volumes	7	335	4	10	1	1	1	445	5	7	0	5	821		
04:00-04:15P	4	106	0	0	1	1	2	88	1	0	0	3	206	802	0.71
04:15-04:30P	3	95	3	3	0	1	0	110	0	2	0	5	222	796	
04:30-04:45P	5	112	2	2	0	0	1	110	0	4	1	8	245	652	
04:45-05:00P	4	116	3	4	0	4	0	84	1	0	0	3	219	632	
05:00-05:15P	5	125	1	5	2	1	1	94	2	0	0	6	242	639	
05:15-05:30P	3	171	1	4	0	0	0	141	2	0	1	0	323	610	
05:30-05:45P	0	58	0	0	0	0	0	47	0	0	0	1	106	589	
05:45-06:00P	1	53	0	0	1	0	0	69	0	0	0	3	127	494	
06:00-06:15P	3	111	0	0	0	0	2	54	4	1	0	2	177	406	
06:15-06:30P	2	102	0	0	0	0	0	71	0	0	0	3	178		
06:30-06:45P	1	88	1	1	0	1	0	71	1	0	0	4	168		
06:45-07:00P	1	47	1	2	0	1	1	56	0	1	0	1	111		
PM PH Volumes	17	524	7	15	2	5	2	429	5	4	2	17	1029		

OR11at9th_RECOUNT_Reduced.xls

TIME	SB			WB			NB			EB			Total	Hour Total	PHF
	RT	TH	LT	RT	TH	LT	RT	TH	LT	RT	TH	LT			
07:00-07:15A	2	85	1	2	0	1	0	88	0	1	0	1	181	714	0.91
07:15-07:30A	1	47	0	2	0	0	1	79	4	0	0	2	136	720	
07:30-07:45A	5	77	2	2	0	0	0	109	0	0	0	4	199	722	
07:45-08:00A	5	74	3	2	1	1	3	103	1	4	0	1	198	646	
08:00-08:15A	3	64	6	6	0	2	0	102	0	2	0	2	187	623	
08:15-08:30A	1	61	0	0	0	1	2	71	0	0	1	1	138		
08:30-08:45A	2	49	2	0	0	0	0	68	0	0	0	2	123		
08:45-09:00A	3	63	2	1	1	0	0	102	0	0	0	3	175		
AM PH Volumes	14	276	11	10	1	4	5	385	1	6	1	8	722		
04:00-04:15P	3	104	7	0	0	0	1	125	0	2	0	1	243	861	0.89
04:15-04:30P	3	94	6	3	0	4	0	83	0	2	0	3	198	816	
04:30-04:45P	4	100	5	1	0	2	1	118	0	1	0	0	232	848	
04:45-05:00P	0	87	4	5	0	2	0	87	0	0	0	3	188	791	
05:00-05:15P	4	104	1	0	0	0	1	88	0	0	0	0	198	794	
05:15-05:30P	2	124	4	1	0	3	0	94	0	1	0	1	230	723	
05:30-05:45P	2	94	2	3	0	0	1	71	2	0	0	0	175	665	
05:45-06:00P	3	83	4	5	0	0	0	94	0	1	0	1	191	604	
06:00-06:15P	0	55	5	0	0	1	0	65	0	0	0	1	127	526	
06:15-06:30P	0	74	7	5	0	0	2	83	0	0	0	1	172		
06:30-06:45P	0	53	4	2	0	0	3	52	0	0	0	0	114		
06:45-07:00P	4	55	4	3	0	0	0	47	0	0	0	0	113		
PM PH Volumes	10	385	22	9	0	8	2	413	0	5	0	7	861		

OR11at8th_Reduced.xls

TIME	SB			WB			NB			EB			Total	Hour Total	PHF
	RT	TH	LT	RT	TH	LT	RT	TH	LT	RT	TH	LT			
07:00-07:15A	1	74	3	3	0	0	0	63	2	2	0	5	153	787	0.88
07:15-07:30A	4	53	0	3	0	0	0	97	0	0	0	7	164	835	
07:30-07:45A	4	82	1	6	1	2	1	134	2	3	0	12	248	873	
07:45-08:00A	2	87	0	2	0	0	1	121	3	3	0	3	222	813	
08:00-08:15A	3	76	1	2	0	0	0	109	1	2	0	7	201	807	
08:15-08:30A	3	78	1	1	0	0	0	113	2	3	0	1	202		
08:30-08:45A	2	86	1	2	0	1	0	91	4	0	0	1	188		
08:45-09:00A	2	82	3	0	0	1	0	115	2	3	1	7	216		
AM PH Volumes	12	323	3	11	1	2	2	477	8	11	0	23	873		
04:00-04:15P	13	94	1	0	0	0	4	91	2	0	0	2	207	964	0.81
04:15-04:30P	10	120	2	1	1	1	0	119	0	2	2	9	267	1003	
04:30-04:45P	12	157	5	0	0	2	5	124	1	0	0	4	310	926	
04:45-05:00P	5	83	1	0	0	0	2	81	3	2	0	3	180	832	
05:00-05:15P	10	133	3	0	0	0	2	90	2	2	1	3	246	868	
05:15-05:30P	5	102	5	0	0	0	1	71	1	1	0	4	190	835	
05:30-05:45P	6	104	3	2	0	0	0	88	2	1	0	10	216	846	
05:45-06:00P	7	99	1	1	0	0	0	93	5	3	0	7	216	765	
06:00-06:15P	10	99	5	2	0	0	0	92	3	1	0	1	213	680	
06:15-06:30P	6	91	2	5	1	0	0	85	1	0	0	10	201		
06:30-06:45P	6	54	5	1	0	0	0	67	1	1	0	0	135		
06:45-07:00P	5	53	1	0	0	1	0	65	2	1	0	3	131		
PM PH Volumes	37	493	11	1	1	3	9	414	6	6	3	19	1003		

OR11at7th_Reduced.xls

TIME	SB			WB			NB			EB			Total	Hour Total	PHF
	RT	TH	LT	RT	TH	LT	RT	TH	LT	RT	TH	LT			
07:00-07:15A	3	72	0	2	0	0	0	91	0	1	0	1	170	785	0.66
07:15-07:30A	3	51	1	2	0	0	0	66	0	0	0	3	126		
07:30-07:45A	3	76	2	7	2	0	0	100	0	0	0	1	191		
07:45-08:00A	1	113	2	1	0	0	1	175	2	1	0	2	298		
AM PH Volumes	10	312	5	12	2	0	1	432	2	2	0	7	785		
04:00-04:15P	7	137	4	0	0	0	0	112	1	3	0	13	277	1023	0.86
04:15-04:30P	4	107	2	1	1	0	2	134	1	0	2	6	260		
04:30-04:45P	3	148	2	2	0	0	0	136	1	0	1	6	299		
04:45-05:00P	2	105	5	4	0	0	0	67	3	0	0	1	187		
05:00-05:15P	1	157	0	5	0	0	0	108	0	0	0	2	273		
05:15-05:30P	3	126	2	3	0	0	1	87	2	1	0	1	226		
05:30-05:45P	2	105	6	1	0	0	0	71	1	0	0	4	190		
05:45-06:00P	5	111	4	3	0	0	1	89	0	0	0	3	216		
PM PH Volumes	16	497	13	7	1	0	2	449	6	3	3	26	1023		

OR8 at S 4th Ave_Reduced.xls

TIME	SB			WB			NB			EB			Total	Hour Total	PHF
	RT	TH	LT	RT	TH	LT	RT	TH	LT	RT	TH	LT			
07:00-07:15A	0	63	1	0	1	0	1	69	1	1	0	1	138	837	0.78
07:15-07:30A	0	76	1	4	0	1	0	114	1	0	0	1	198		
07:30-07:45A	1	87	0	1	0	0	0	140	1	0	0	1	231		
07:45-08:00A	0	119	2	3	0	0	0	145	0	0	0	1	270		
AM PH Volumes	1	345	4	8	1	1	1	468	3	1	0	4	837		
04:00-04:15P	1	156	0	4	1	0	0	136	1	0	0	2	301	1169	0.87
04:15-04:30P	2	180	3	2	0	0	0	148	2	0	0	0	337		
04:30-04:45P	1	105	3	2	0	0	3	89	1	1	0	1	206		
04:45-05:00P	0	173	1	2	0	0	0	148	0	0	0	1	325		
05:00-05:15P	3	159	2	3	0	0	0	118	0	0	0	1	286		
05:15-05:30P	1	173	5	1	0	1	0	113	0	0	0	0	294		
05:30-05:45P	2	130	2	2	0	0	0	94	0	1	0	0	231		
05:45-06:00P	0	157	1	1	0	0	5	130	4	0	0	0	298		
PM PH Volumes	4	614	7	10	1	0	3	521	4	1	0	4	1169		

OR11at2nd_RECOUNT_Reduced.xls

TIME	SB			WB			NB			EB			Total	Hour Total	PHF
	RT	TH	LT	RT	TH	LT	RT	TH	LT	RT	TH	LT			
07:00-07:15A	0	25	0	0	3	67	38	27	5	0	0	0	165	969	0.90
07:15-07:30A	0	35	0	1	7	57	81	44	5	3	0	4	237	1050	
07:30-07:45A	0	41	0	0	4	68	123	40	6	7	0	3	292	937	
07:45-08:00A	0	51	0	0	7	69	98	47	2	1	0	0	275	922	
08:00-08:15A	0	32	0	0	1	68	105	39	1	0	0	0	246	803	
08:15-08:30A	1	16	0	0	0	45	46	15	0	1	0	0	124		
08:30-08:45A	1	30	0	0	1	84	117	39	2	3	0	0	277		
08:45-09:00A	0	23	0	4	3	44	56	20	0	3	2	1	156		
AM PH Volumes	0	159	0	1	19	262	407	170	14	11	0	7	1050		
04:00-04:15P	5	43	0	1	11	130	105	42	1	0	0	0	338	1327	0.92
04:15-04:30P	1	42	0	2	5	126	125	55	0	3	0	3	362	1304	
04:30-04:45P	5	52	0	0	10	116	82	46	4	3	0	2	320	1235	
04:45-05:00P	1	52	0	3	5	109	86	44	2	3	2	0	307	1178	
05:00-05:15P	3	53	0	1	12	143	70	23	3	5	0	2	315	1173	
05:15-05:30P	0	35	0	0	10	131	83	29	1	3	0	1	293	1139	
05:30-05:45P	1	41	0	1	6	111	77	21	1	2	0	2	263	1060	
05:45-06:00P	1	62	0	0	8	129	60	34	4	2	0	2	302	956	
06:00-06:15P	2	30	0	1	9	121	72	40	1	5	0	0	281	839	
06:15-06:30P	2	34	0	2	7	85	50	24	4	4	0	2	214		
06:30-06:45P	4	15	0	1	6	68	47	15	1	1	0	1	159		
06:45-07:00P	0	29	0	0	5	78	38	27	3	1	0	4	185		
PM PH Volumes	12	189	0	6	31	481	398	187	7	9	2	5	1327		

Appendix B

**Existing Traffic Condition
Analysis Worksheets**

Kittelson & Associates, Inc. - Project # 6743
Milton-Freewater STA and TSP Update, Milton-Freewater, OR
2004 Existing Traffic Condition, Weeday AM Peak Hour

Scenario: AM Scenario Report
Command: AM
Volume: AM
Geometry: EX
Impact Fee: Default Impact Fee
Trip Generation: Default Trip Generation
Trip Distribution: Default Trip Distribution
Paths: Default Paths
Routes: Default Routes
Configuration: Default Configuration

Kittelson & Associates, Inc. - Project # 6743
Milton-Freewater STA and TSP Update, Milton-Freewater, OR
2004 Existing Traffic Condition, Weeday AM Peak Hour

Impact Analysis Report
Level Of Service

Intersection	Base		Future		Change in
	LOS	Del/Veh C	LOS	Del/Veh C	
# 1 OR 11/ 14th Ave	C	16.9 0.000	C	16.9 0.000	+ 0.000 D/V
# 2 Main Street-OR11/ 12th Ave	C	24.2 0.000	C	24.2 0.000	+ 0.000 D/V
# 3 Main Street - OR 11/ 10th Ave	C	16.4 0.000	C	16.4 0.000	+ 0.000 D/V
# 4 Main Street - OR 11/ 9th Ave	C	18.2 0.000	C	18.2 0.000	+ 0.000 D/V
# 5 Main Street-OR11/ 8th Ave	C	19.7 0.000	C	19.7 0.000	+ 0.000 D/V
# 6 OR 11/7th Ave - Eastbound	C	24.5 0.000	C	24.5 0.000	+ 0.000 D/V
# 7 OR 11/7th Avenue - Westbound	B	14.0 0.000	B	14.0 0.000	+ 0.000 D/V
# 8 OR 11/ 4th Avenue	D	26.2 0.000	D	26.2 0.000	+ 0.000 D/V
# 9 Main Street/OR11/ 2nd Ave	C	20.4 0.239	C	20.4 0.239	+ 0.000 D/V

Kittelson & Associates, Inc. - Project # 6743
Milton-Freewater STA and TSP Update, Milton-Freewater, OR
2004 Existing Traffic Condition, Weeday AM Peak Hour

Signal Warrant Summary Report

Intersection	Base Met [Del / Vol]	Future Met [Del / Vol]
# 1 OR 11/ 14th Ave	???	No / No
# 2 Main Street-OR11/ 12th Ave	???	No / No
# 3 Main Street - OR 11/ 10th Ave	???	No / No
# 4 Main Street - OR 11/ 9th Ave	???	No / No
# 5 Main Street-OR11/ 8th Ave	???	No / No
# 6 OR 11/7th Ave - Eastbound	???	No / No
# 7 OR 11/7th Avenue - Westbound	???	No / No
# 8 OR 11/ 4th Avenue	???	No / No

Kittelson & Associates, Inc. - Project # 6743
Milton-Freewater STA and TSP Update, Milton-Freewater, OR
2004 Existing Traffic Condition, Weeday AM Peak Hour

Peak Hour Delay Signal Warrant Report

Intersection #1 OR 11/ 14th Ave

Future Volume Alternative: Peak Hour Warrant NOT Met

Approach:	North Bound	South Bound	East Bound	West Bound
Movement:	L - T - R	L - T - R	L - T - R	L - T - R
Control:	Uncontrolled	Uncontrolled	Stop Sign	Stop Sign
Lanes:	0 0 0 1 0	0 1 1 0 0	0 0 0 0 0	1 0 0 0 1
Final Vol.:	0 544 19	154 437 0	0 0 0 0	17 0 217
ApproachDel:	xxxxxx	xxxxxx	xxxxxx	16.9

Approach[westbound][lanes=2][control=Stop]
 Signal Warrant Rule #1: [vehicle-hours=1.1]
 FAIL - Vehicle-hours less than 5 for two or more lane approach.
 Signal Warrant Rule #2: [approach volume=234]
 SUCCEED - Approach volume >= 150 for two or more lane approach.
 Signal Warrant Rule #3: [approach count=3][total volume=1388]
 SUCCEED - Total volume greater than or equal to 650 for intersection
 with less than four approaches.

Kittelson & Associates, Inc. - Project # 6743
Milton-Freewater STA and TSP Update, Milton-Freewater, OR
2004 Existig Traffic Condition, Weeday AM Peak Hour

Peak Hour Volume Signal Warrant Report [Urban]

Intersection #1 OR 11/ 14th Ave

Future Volume Alternative: Peak Hour Warrant NOT Met

Approach:	North Bound	South Bound	East Bound	West Bound
Movement:	L - T - R	L - T - R	L - T - R	L - T - R
Control:	Uncontrolled	Uncontrolled	Stop Sign	Stop Sign
Lanes:	0 0 0 1 0	0 1 1 0 0	0 0 0 0 0	1 0 0 0 1
Final Vol.:	0 544 19	154 437 0	0 0 0 0	17 0 217
Major Street Volume:	1154			
Minor Approach Volume:	234			
Minor Approach Volume Threshold:	313			

Kittelson & Associates, Inc. - Project # 6743
Milton-Freewater STA and TSP Update, Milton-Freewater, OR
2004 Existig Traffic Condition, Weeday AM Peak Hour

Peak Hour Delay Signal Warrant Report

Intersection #2 Main Street-OR11/ 12th Ave

Future Volume Alternative: Peak Hour Warrant NOT Met

Approach:	North Bound	South Bound	East Bound	West Bound
Movement:	L - T - R	L - T - R	L - T - R	L - T - R
Control:	Uncontrolled	Uncontrolled	Stop Sign	Stop Sign
Lanes:	0 1 0 1 0	0 1 0 1 0	0 0 1 0 0	0 0 1 0 0
Final Vol.:	5 664 3	13 528 9	45 3 8	4 1 19
ApproachDel:	xxxxxx	xxxxxx	24.2	13.7

Approach[eastbound] [lanes=1] [control=Stop]
Signal Warrant Rule #1: [vehicle-hours=0.4]
FAIL - Vehicle-hours less than 4 for one lane approach.
Signal Warrant Rule #2: [approach volume=55]
FAIL - Approach volume less than 100 for one lane approach.
Signal Warrant Rule #3: [approach count=4][total volume=1299]
SUCCEED - Total volume greater than or equal to 800 for intersection with four or more approaches.

Approach[westbound] [lanes=1] [control=Stop]
Signal Warrant Rule #1: [vehicle-hours=0.1]
FAIL - Vehicle-hours less than 4 for one lane approach.
Signal Warrant Rule #2: [approach volume=24]
FAIL - Approach volume less than 100 for one lane approach.
Signal Warrant Rule #3: [approach count=4][total volume=1299]
SUCCEED - Total volume greater than or equal to 800 for intersection with four or more approaches.

Kittelson & Associates, Inc. - Project # 6743
Milton-Freewater STA and TSP Update, Milton-Freewater, OR
2004 Existing Traffic Condition, Weeday AM Peak Hour

Peak Hour Volume Signal Warrant Report (Urban)

Intersection #2 Main Street-OR11/ 12th Ave

Future Volume Alternative: Peak Hour Warrant NOT Met

Approach:	North Bound	South Bound	East Bound	West Bound
Movement:	L - T - R	L - T - R	L - T - R	L - T - R
Control:	Uncontrolled	Uncontrolled	Stop Sign	Stop Sign
Lanes:	0 1 0 1 0	0 1 0 1 0	0 0 1 0 0	0 0 1 0 0
Final Vol.:	5 664 3	13 528 9	45 3 8	4 1 19

Major Street Volume: 1221
Minor Approach Volume: 55
Minor Approach Volume Threshold: 216

Kittelson & Associates, Inc. - Project # 6743
Milton-Freewater STA and TSP Update, Milton-Freewater, OR
2004 Existing Traffic Condition, Weeday AM Peak Hour

Peak Hour Delay Signal Warrant Report

Intersection #3 Main Street - OR 11/ 10th Ave

Future Volume Alternative: Peak Hour Warrant NOT Met

Approach:	North Bound	South Bound	East Bound	West Bound
Movement:	L - T - R	L - T - R	L - T - R	L - T - R
Control:	Uncontrolled	Uncontrolled	Stop Sign	Stop Sign
Lanes:	0 1 0 1 0	0 1 0 1 0	0 0 1 0 0	0 0 1 0 0
Final Vol.:	6 647 1	5 482 9	8 1 6	1 1 13
ApproachDel:	xxxxxx	xxxxxx	16.4	12.4

Approach[eastbound] [lanes=1] [control=Stop]
Signal Warrant Rule #1: [vehicle-hours=0.1]
FAIL - Vehicle-hours less than 4 for one lane approach.
Signal Warrant Rule #2: [approach volume=15]
FAIL - Approach volume less than 100 for one lane approach.
Signal Warrant Rule #3: [approach count=4] [total volume=1179]
SUCCEED - Total volume greater than or equal to 800 for intersection with four or more approaches.

Approach[westbound] [lanes=1] [control=Stop]
Signal Warrant Rule #1: [vehicle-hours=0.1]
FAIL - Vehicle-hours less than 4 for one lane approach.
Signal Warrant Rule #2: [approach volume=15]
FAIL - Approach volume less than 100 for one lane approach.
Signal Warrant Rule #3: [approach count=4] [total volume=1179]
SUCCEED - Total volume greater than or equal to 800 for intersection with four or more approaches.

Kittelson & Associates, Inc. - Project # 6743
Milton-Freewater STA and TSP Update, Milton-Freewater, OR
2004 Existig Traffic Condition, Weeday AM Peak Hour

Peak Hour Volume Signal Warrant Report (Urban)

Intersection #3 Main Street - OR 11/ 10th Ave

Future Volume Alternative: Peak Hour Warrant NOT Met

Approach:	North Bound	South Bound	East Bound	West Bound
Movement:	L - T - R	L - T - R	L - T - R	L - T - R
Control:	Uncontrolled	Uncontrolled	Stop Sign	Stop Sign
Lanes:	0 1 0 1 0	0 1 0 1 0	0 0 1 0 0	0 0 1 0 0
Final Vol.:	6 647 1	5 482 9	8 1 6	1 1 13
Major Street Volume:	1150			
Minor Approach Volume:	15			
Minor Approach Volume Threshold:	237			

Kittelson & Associates, Inc. - Project # 6743
Milton-Freewater STA and TSP Update, Milton-Freewater, OR
2004 Existig Traffic Condition, Weeday AM Peak Hour

Peak Hour Delay Signal Warrant Report

Intersection #4 Main Street - OR 11/ 9th Ave

Future Volume Alternative: Peak Hour Warrant NOT Met

Approach:	North Bound	South Bound	East Bound	West Bound
Movement:	L - T - R	L - T - R	L - T - R	L - T - R
Control:	Uncontrolled	Uncontrolled	Stop Sign	Stop Sign
Lanes:	0 1 0 1 0	0 1 0 1 0	0 0 1 0 0	0 0 1 0 0
Final Vol.:	1 681 5	16 497 21	12 1 7	4 1 14
ApproachDel:	xxxxxx	xxxxxx	18.2	14.6

Approach[Eastbound] [lanes=1] [control=Stop]
Signal Warrant Rule #1: [vehicle-hours=0.1]
FAIL - Vehicle-hours less than 4 for one lane approach.
Signal Warrant Rule #2: [approach volume=20]
FAIL - Approach volume less than 100 for one lane approach.
Signal Warrant Rule #3: [approach count=4][total volume=1262]
SUCCEED - Total volume greater than or equal to 800 for intersection with four or more approaches.

Approach[Westbound] [lanes=1] [control=Stop]
Signal Warrant Rule #1: [vehicle-hours=0.1]
FAIL - Vehicle-hours less than 4 for one lane approach.
Signal Warrant Rule #2: [approach volume=20]
FAIL - Approach volume less than 100 for one lane approach.
Signal Warrant Rule #3: [approach count=4][total volume=1262]
SUCCEED - Total volume greater than or equal to 800 for intersection with four or more approaches.

Kittelson & Associates, Inc. - Project # 6743
Milton-Freewater STA and TSP Update, Milton-Freewater, OR
2004 Existing Traffic Condition, Weeday AM Peak Hour

Peak Hour Volume Signal Warrant Report [Urban]

Intersection #4 Main Street - OR 11/ 9th Ave

Future Volume Alternative: Peak Hour Warrant NOT Met

Approach:	North Bound	South Bound	East Bound	West Bound
Movement:	L - T - R	L - T - R	L - T - R	L - T - R
Control:	Uncontrolled	Uncontrolled	Stop Sign	Stop Sign
Lanes:	0 1 0 1 0	0 1 0 1 0	0 0 1 0 0	0 0 1 0 0
Final Vol.:	1 681 5	16 497 21	12 1 7	4 1 14

Major Street Volume: 1222
Minor Approach Volume: 20
Minor Approach Volume Threshold: 216

Kittelson & Associates, Inc. - Project # 6743
Milton-Freewater STA and TSP Update, Milton-Freewater, OR
2004 Existing Traffic Condition, Weeday AM Peak Hour

Peak Hour Delay Signal Warrant Report

Intersection #5 Main Street-OR11/ 8th Ave

Future Volume Alternative: Peak Hour Warrant NOT Met

Approach:	North Bound	South Bound	East Bound	West Bound
Movement:	L - T - R	L - T - R	L - T - R	L - T - R
Control:	Uncontrolled	Uncontrolled	Stop Sign	Stop Sign
Lanes:	0 1 0 1 0	0 1 0 1 0	0 0 1 0 0	0 0 1 0 0
Final Vol.:	9 682 2	3 512 17	28 1 13	2 1 14
ApproachDel:	xxxxxx	xxxxxx	19.7	13.5

Approach [eastbound] [lanes=1] [control=Stop]
Signal Warrant Rule #1: [vehicle-hours=0.2]
FAIL - Vehicle-hours less than 4 for one lane approach.
Signal Warrant Rule #2: [approach volume=42]
FAIL - Approach volume less than 100 for one lane approach.
Signal Warrant Rule #3: [approach count=4] [total volume=1285]
SUCCEED - Total volume greater than or equal to 800 for intersection with four or more approaches.

Approach [westbound] [lanes=1] [control=Stop]
Signal Warrant Rule #1: [vehicle-hours=0.1]
FAIL - Vehicle-hours less than 4 for one lane approach.
Signal Warrant Rule #2: [approach volume=17]
FAIL - Approach volume less than 100 for one lane approach.
Signal Warrant Rule #3: [approach count=4] [total volume=1285]
SUCCEED - Total volume greater than or equal to 800 for intersection with four or more approaches.

Kittelson & Associates, Inc. - Project # 6743
Milton-Freewater STA and TSP Update, Milton-Freewater, OR
2004 Existing Traffic Condition, Weeday AM Peak Hour

Peak Hour Volume Signal Warrant Report [Urban]

Intersection #5 Main Street-OR11/ 8th Ave

Future Volume Alternative: Peak Hour Warrant NOT Met

Approach:	North Bound			South Bound			East Bound			West Bound							
Movement:	L	T	R	L	T	R	L	T	R	L	T	R					
Control:	Uncontrolled			Uncontrolled			Stop Sign			Stop Sign							
Lanes:	0	1	0	1	0	1	0	0	0	1	0	0	0	0	1	0	0
Final Vol.:	9	682	2	3	512	17	28	1	13	2	1	14					
Major Street Volume:	1226																
Minor Approach Volume:	42																
Minor Approach Volume Threshold:	215																

Kittelson & Associates, Inc. - Project # 6743
Milton-Freewater STA and TSP Update, Milton-Freewater, OR
2004 Existing Traffic Condition, Weeday AM Peak Hour

Peak Hour Delay Signal Warrant Report

Intersection #6 OR 11/7th Ave - Eastbound

Future Volume Alternative: Peak Hour Warrant NOT Met

Approach:	North Bound			South Bound			East Bound			West Bound							
Movement:	L	T	R	L	T	R	L	T	R	L	T	R					
Control:	Uncontrolled			Uncontrolled			Stop Sign			Stop Sign							
Lanes:	0	1	0	1	0	1	0	0	0	1	0	0	0	0	1	0	0
Final Vol.:	3	937	0	0	688	19	10	1	3	0	0	0					
ApproachDel:	xxxxxx			xxxxxx			24.5			xxxxxx							

Approach [eastbound] [lanes=1] [control=Stop]
 Signal Warrant Rule #1: [vehicle-hours=0.1]
 FAIL - Vehicle-hours less than 4 for one lane approach.
 Signal Warrant Rule #2: [approach volume=14]
 FAIL - Approach volume less than 100 for one lane approach.
 Signal Warrant Rule #3: [approach count=3][total volume=1661]
 SUCCEED - Total volume greater than or equal to 650 for intersection,
 with less than four approaches.

Kittelson & Associates, Inc. - Project # 6743
Milton-Freewater STA and TSP Update, Milton-Freewater, OR
2004 Existig Traffic Condition, Weeday AM Peak Hour

Peak Hour Volume Signal Warrant Report [Urban]

Intersection #6 OR 11/7th Ave - Eastbound

Future Volume Alternative: Peak Hour Warrant NOT Met

Approach:	North Bound	South Bound	East Bound	West Bound
Movement:	L - T - R	L - T - R	L - T - R	L - T - R
Control:	Uncontrolled	Uncontrolled	Stop Sign	Stop Sign
Lanes:	0 1 0 1 0	0 1 0 1 0	0 0 1 0 0	0 0 1 0 0
Final Vol.:	3 937 0	0 688 19	10 1 3	0 0 0 0

Major Street Volume: 1646
Minor Approach Volume: 14
Minor Approach Volume Threshold: 113

Kittelson & Associates, Inc. - Project # 6743
Milton-Freewater STA and TSP Update, Milton-Freewater, OR
2004 Existig Traffic Condition, Weeday AM Peak Hour

Peak Hour Delay Signal Warrant Report

Intersection #7 OR 11/7th Avenue - Westbound

Future Volume Alternative: Peak Hour Warrant NOT Met

Approach:	North Bound	South Bound	East Bound	West Bound
Movement:	L - T - R	L - T - R	L - T - R	L - T - R
Control:	Uncontrolled	Uncontrolled	Stop Sign	Stop Sign
Lanes:	0 1 0 1 0	0 1 0 1 0	0 0 0 0 0	0 0 1 0 0
Final Vol.:	0 937 1	10 688 0	0 0 0 0	0 0 1 0 23
ApproachDel:	xxxxxx	xxxxxx	xxxxxx	14.0

Approach [westbound] [lanes=1] [control=Stop]
Signal Warrant Rule #1: [vehicle hours=0.1]
FAIL - Vehicle-hours less than 4 for one lane approach.
Signal Warrant Rule #2: [approach volume=26]
FAIL - Approach volume less than 100 for one lane approach.
Signal Warrant Rule #3: [approach count=3] [total volume=1662]
SUCCEED - Total volume greater than or equal to 650 for intersection with less than four approaches.

Kittelson & Associates, Inc. - Project # 6743
Milton-Freewater STA and TSP Update, Milton-Freewater, OR
2004 Existing Traffic Condition, Weeday AM Peak Hour

Peak Hour Volume Signal Warrant Report (Urban)

Intersection #7 OR 11/7th Avenue - Westbound

Future Volume Alternative: Peak Hour Warrant NOT Met

Approach:	North Bound	South Bound	East Bound	West Bound
Movement:	L - T - R	L - T - R	L - T - R	L - T - R
Control:	Uncontrolled	Uncontrolled	Stop Sign	Stop Sign
Lanes:	0 1 0 1 0	0 1 0 1 0	0 0 0 0 0	0 0 1 0 0
Final Vol.:	0 937 1	10 688 0	0 0 0 0	3 0 23

Major Street Volume: 1636
Minor Approach Volume: 26
Minor Approach Volume Threshold: 115

Kittelson & Associates, Inc. - Project # 6743
Milton-Freewater STA and TSP Update, Milton-Freewater, OR
2004 Existing Traffic Condition, Weeday AM Peak Hour

Peak Hour Delay Signal Warrant Report

Intersection #8 OR 11/ 4th Avenue

Future Volume Alternative: Peak Hour Warrant NOT Met

Approach:	North Bound	South Bound	East Bound	West Bound
Movement:	L - T - R	L - T - R	L - T - R	L - T - R
Control:	Uncontrolled	Uncontrolled	Stop Sign	Stop Sign
Lanes:	0 1 0 1 0	0 1 0 1 0	0 0 1 0 0	0 0 1 0 0
Final Vol.:	4 849 1	6 628 1	6 1 1	1 1 13
ApproachDel:	xxxxxx	xxxxxx	26.2	15.1

Approach[eastbound] [lanes=1] [control=Stop]
Signal Warrant Rule #1: [vehicle-hours=0.1]
FAIL - Vehicle-hours less than 4 for one lane approach.
Signal Warrant Rule #2: [approach volume=9]
FAIL - Approach volume less than 100 for one lane approach.
Signal Warrant Rule #3: [approach count=4][total volume=1514]
SUCCEED - Total volume greater than or equal to 800 for intersection with four or more approaches.

Approach[westbound] [lanes=1] [control=Stop]
Signal Warrant Rule #1: [vehicle-hours=0.1]
FAIL - Vehicle-hours less than 4 for one lane approach.
Signal Warrant Rule #2: [approach volume=15]
FAIL - Approach volume less than 100 for one lane approach.
Signal Warrant Rule #3: [approach count=4][total volume=1514]
SUCCEED - Total volume greater than or equal to 800 for intersection with four or more approaches.

Kittelson & Associates, Inc. - Project # 6743
Milton-Freewater STA and TSP Update, Milton-Freewater, OR
2004 Existig Traffic Condition, Weeday AM Peak Hour

Peak Hour Volume Signal Warrant Report (Urban)

Intersection #8 OR 11/ 4th Avenue

Future Volume Alternative: Peak Hour Warrant NOT Met

Approach:	North Bound	South Bound	East Bound	West Bound
Movement:	L - T - R	L - T - R	L - T - R	L - T - R
Control:	Uncontrolled	Uncontrolled	Stop Sign	Stop Sign
Lanes:	0 1 0 1 0	0 1 0 1 0	0 0 1 0 0	0 0 1 0 0
Final Vol.:	4 849 1	6 628 1	6 1 1	1 1 13
Major Street Volume:	1490			
Minor Approach Volume:	15			
Minor Approach Volume Threshold:	147			

Kittelson & Associates, Inc. - Project # 6743
Milton-Freewater STA and TSP Update, Milton-Freewater, OR
2004 Existig Traffic Condition, Weeday AM Peak Hour

Level Of Service Computation Report

2000 HCM Unsignalized Method (Base Volume Alternative)

Intersection #1 OR 11/ 14th Ave

Average Delay (sec/veh): 3.9 Worst Case Level Of Service: C (16.9)

Approach:	North Bound	South Bound	East Bound	West Bound
Movement:	L - T - R	L - T - R	L - T - R	L - T - R
Control:	Uncontrolled	Uncontrolled	Stop Sign	Stop Sign
Rights:	Include	Include	Include	Channel
Lanes:	0 0 0 1 0	0 1 1 0 0	0 0 0 0 0	1 0 0 0 1

Volume Module:	>> Count	Date:	1 Dec 2004	<<
Base Vol:	0 323 13	108 259	0	0 0 0
Growth Adj:	1.00 1.18 1.00	1.00 1.18 1.00	1.00	1.00 1.00 1.00
Initial Bse:	0 381 13	108 306	0	0 0 0
User Adj:	1.00 1.00 1.00	1.00 1.00 1.00	1.00	1.00 1.00 1.00
PHF Adj:	0.70 0.70 0.70	0.70 0.70 0.70	0.70	0.70 0.70 0.70
PHF Volume:	0 544 19	154 437	0	0 0 0
Reduct Vol:	0 0 0	0 0 0	0	0 0 0
Final Vol.:	0 544 19	154 437	0	0 0 0

Critical Gap Module:	Critical Gp:	xxxxx xxxx xxxxx	4.1 xxxx xxxxx xxxxx xxxx xxxxx	6.4 xxxx 6.2
FollowUpTim:	xxxxx xxxx xxxxx	2.2 xxxx xxxxx xxxxx xxxx xxxxx	3.5 xxxx 3.3	

Capacity Module:	Cnflct Vol:	xxxx xxxx xxxxx	563 xxxx xxxxx xxxx xxxx xxxxx	1081 xxxx 554
Potent Cap.:	xxxx xxxx xxxxx	1008 xxxx xxxxx xxxx xxxx xxxxx	241 xxxx 532	
Move Cap.:	xxxx xxxx xxxxx	1008 xxxx xxxxx xxxx xxxx xxxxx	210 xxxx 532	
Volume/Cap:	xxxx xxxx xxxxx	0.15 xxxx xxxxx xxxx xxxx xxxxx	0.08 xxxx 0.41	

Level Of Service Module:	Queue:	xxxxx xxxx xxxxx	0.5 xxxx xxxxx xxxxx xxxx xxxxx	0.3 xxxx 2.0
Stopped Del:	xxxxx xxxx xxxxx	9.2 xxxx xxxxx xxxxx xxxx xxxxx	23.6 xxxx 16.3	
LOS by Move:	* * *	A * * * * * C * C		
Movement:	LT - LTR - RT	LT - LTR - RT LT - LTR - RT LT - LTR - RT		
Shared Cap.:	xxxx xxxx xxxxx	xxxx xxxx xxxxx xxxx xxxx xxxxx xxxx xxxx xxxxx		
Shared Queue:	xxxx xxxx xxxxx	0.5 xxxx xxxxx xxxxx xxxx xxxxx xxxxx xxxx xxxxx		
Shrd StpDel:	xxxxx xxxx xxxxx	9.2 xxxx xxxxx xxxxx xxxx xxxxx xxxxx xxxx xxxxx		
Shared LOS:	* * *	A * * * * * * * * * *		
ApproachDel:	xxxxxx	xxxxxx xxxxxx	16.9	
ApproachLOS:	*	* * C		

Kittelson & Associates, Inc. - Project # 6743
Milton-Freewater STA and TSP Update, Milton-Freewater, OR
2004 Existig Traffic Condition, Weeday AM Peak Hour

Level Of Service Computation Report
2000 HCM Unsignalized Method (Base Volume Alternative)

Intersection #2 Main Street-OR11/ 12th Ave

Average Delay (sec/veh): 1.4 Worst Case Level Of Service: C [24.2]

Approach:	North Bound	South Bound	East Bound	West Bound
Movement:	L - T - R	L - T - R	L - T - R	L - T - R
Control:	Uncontrolled	Uncontrolled	Stop Sign	Stop Sign
Rights:	Include	Include	Include	Include
Lanes:	0 1 0 1 0	0 1 0 1 0	0 0 1 0 0	0 0 1 0 0

Volume Module:	>> Count Date:	7 Dec 2004 <<
Base Vol:	4 450 2	10 358 7 36 2 6 3 1 15
Growth Adj:	1.00 1.18 1.00	1.00 1.18 1.00 1.00 1.00 1.00 1.00 1.00 1.00
Initial Bse:	4 531 2	10 422 7 36 2 6 3 1 15
User Adj:	1.00 1.00 1.00	1.00 1.00 1.00 1.00 1.00 1.00 1.00 1.00 1.00
PHF Adj:	0.80 0.80 0.80	0.80 0.80 0.80 0.80 0.80 0.80 0.80 0.80 0.80
PHF Volume:	5 664 3	13 528 9 45 3 8 4 1 19
Reduct Vol:	0 0 0	0 0 0 0 0 0 0 0 0
Final Vol.:	5 664 3	13 528 9 45 3 8 4 1 19

Critical Gap Module:	
Critical Gp:	4.1 xxxx xxxxx 4.1 xxxx xxxxx 7.5 6.5 6.9 7.5 6.5 6.9
FollowUpTim:	2.2 xxxx xxxxx 2.2 xxxx xxxxx 3.5 4.0 3.3 3.5 4.0 3.3

Capacity Module:	
Cnflct Vol:	537 xxxx xxxxx 666 xxxx xxxxx 900 1234 268 965 1237 333
Potent Cap.:	1027 xxxx xxxxx 919 xxxx xxxxx 234 175 730 209 175 663
Move Cap.:	1027 xxxx xxxxx 919 xxxx xxxxx 222 172 730 202 171 663
Volume/Cap:	0.00 xxxx xxxxx 0.01 xxxx xxxxx 0.20 0.01 0.01 0.02 0.01 0.03

Level Of Service Module:	
Queue:	0.0 xxxx xxxxx 0.0 xxxx xxxxx xxxxx xxxxx xxxxx xxxxx xxxxx xxxxx
Stopped Del:	8.5 xxxx xxxxx 9.0 xxxx xxxxx xxxxx xxxxx xxxxx xxxxx xxxxx xxxxx
LOS by Move:	A * * A * * A * * A * * A * * A * *
Movement:	LT - LTR - RT LT - LTR - RT LT - LTR - RT LT - LTR - RT
Shared Cap.:	xxxx xxxx xxxxx xxxxx xxxxx xxxxx 242 xxxxx xxxxx 439 xxxxx
SharedQueue:	0.0 xxxx xxxxx 0.0 xxxx xxxxx xxxxx 0.9 xxxxx xxxxx 0.2 xxxxx
Shrd StpDel:	8.5 xxxx xxxxx 9.0 xxxx xxxxx xxxxx 24.2 xxxxx xxxxx 13.7 xxxxx
Shared LOS:	A * * A * * C * * B * *
ApproachDel:	xxxxxx xxxxxx 24.2 13.7
ApproachLOS:	* * C B

Kittelson & Associates, Inc. - Project # 6743
Milton-Freewater STA and TSP Update, Milton-Freewater, OR
2004 Existig Traffic Condition, Weeday AM Peak Hour

Level Of Service Computation Report
2000 HCM Unsignalized Method (Base Volume Alternative)

Intersection #3 Main Street - OR 11/ 10th Ave

Average Delay (sec/veh): 0.4 Worst Case Level Of Service: C [16.4]

Approach:	North Bound	South Bound	East Bound	West Bound
Movement:	L - T - R	L - T - R	L - T - R	L - T - R
Control:	Uncontrolled	Uncontrolled	Stop Sign	Stop Sign
Rights:	Include	Include	Include	Include
Lanes:	0 1 0 1 0	0 1 0 1 0	0 0 1 0 0	0 0 1 0 0

Volume Module:	>> Count Date:	18 Nov 2004 <<
Base Vol:	5 495 1	4 369 8 7 1 5 1 1 11
Growth Adj:	1.00 1.15 1.00	1.00 1.15 1.00 1.00 1.00 1.00 1.00 1.00 1.00
Initial Bse:	5 569 1	4 424 8 7 1 5 1 1 11
User Adj:	1.00 1.00 1.00	1.00 1.00 1.00 1.00 1.00 1.00 1.00 1.00 1.00
PHF Adj:	0.88 0.88 0.88	0.88 0.88 0.88 0.88 0.88 0.88 0.88 0.88 0.88
PHF Volume:	6 647 1	5 482 9 8 1 6 1 1 13
Reduct Vol:	0 0 0	0 0 0 0 0 0 0 0 0
Final Vol.:	6 647 1	5 482 9 8 1 6 1 1 13

Critical Gap Module:	
Critical Gp:	4.1 xxxx xxxxx 4.1 xxxx xxxxx 7.5 6.5 6.9 7.5 6.5 6.9
FollowUpTim:	2.2 xxxx xxxxx 2.2 xxxx xxxxx 3.5 4.0 3.3 3.5 4.0 3.3

Capacity Module:	
Cnflct Vol:	491 xxxx xxxxx 648 xxxx xxxxx 831 1155 246 910 1159 324
Potent Cap.:	1068 xxxx xxxxx 934 xxxx xxxxx 262 195 755 230 194 672
Move Cap.:	1068 xxxx xxxxx 934 xxxx xxxxx 254 193 755 225 192 672
Volume/Cap:	0.01 xxxx xxxxx 0.00 xxxx xxxxx 0.03 0.01 0.01 0.01 0.01 0.02

Level Of Service Module:	
Queue:	0.0 xxxx xxxxx 0.0 xxxx xxxxx xxxxx xxxxx xxxxx xxxxx xxxxx xxxxx
Stopped Del:	8.4 xxxx xxxxx 8.9 xxxx xxxxx xxxxx xxxxx xxxxx xxxxx xxxxx xxxxx
LOS by Move:	A * * A * * A * * A * * A * * A * *
Movement:	LT - LTR - RT LT - LTR - RT LT - LTR - RT LT - LTR - RT
Shared Cap.:	xxxx xxxx xxxxx 439 xxxxx xxxxx xxxxx 330 xxxxx xxxxx 500 xxxxx
SharedQueue:	0.0 xxxx xxxxx 0.0 xxxx xxxxx xxxxx 0.1 xxxxx xxxxx 0.1 xxxxx
Shrd StpDel:	8.4 xxxx xxxxx 8.9 xxxx xxxxx xxxxx 16.4 xxxxx xxxxx 12.4 xxxxx
Shared LOS:	A * * A * * C * * B * *
ApproachDel:	xxxxxx xxxxxx 16.4 12.4
ApproachLOS:	* * C B

Kittelson & Associates, Inc. - Project # 6743
 Milton-Freewater STA and TSP Update, Milton-Freewater, OR
 2004 Existig Traffic Condition, Weeday AM Peak Hour

Level Of Service Computation Report
 2000 HCM Unsignalized Method (Base Volume Alternative)

Intersection #4 Main Street - OR 11/ 9th Ave

Average Delay (sec/veh): 0.6 Worst Case Level Of Service: C [18.2]

Approach:	North Bound	South Bound	East Bound	West Bound
Movement:	L - T - R	L - T - R	L - T - R	L - T - R
Control:	Uncontrolled	Uncontrolled	Stop Sign	Stop Sign
Rights:	Include	Include	Include	Include
Lanes:	0 1 0 1 0	0 1 0 1 0	0 0 1 0 0	0 0 1 0 0
Volume Module: >> Count Date: 22 Dec 2004 <<				
Base Vol:	1 508 5	15 371 19	11 1 6	4 1 13
Growth Adj:	1.00 1.22 1.00	1.00 1.22 1.00	1.00 1.00 1.00	1.00 1.00 1.00
Initial Bse:	1 620 5	15 453 19	11 1 6	4 1 13
User Adj:	1.00 1.00 1.00	1.00 1.00 1.00	1.00 1.00 1.00	1.00 1.00 1.00
PHF Adj:	0.91 0.91 0.91	0.91 0.91 0.91	0.91 0.91 0.91	0.91 0.91 0.91
PHF Volume:	1 681 5	16 497 21	12 1 7	4 1 14
Reduct Vol:	0 0 0	0 0 0	0 0 0	0 0 0
Final Vol.:	1 681 5	16 497 21	12 1 7	4 1 14
Critical Gap Module:				
Critical Gp:	4.1 xxxx xxxxx	4.1 xxxx xxxxx	7.5 6.5 6.9	7.5 6.5 6.9
FollowUpTim:	2.2 xxxx xxxxx	2.2 xxxx xxxxx	3.5 4.0 3.3	3.5 4.0 3.3
Capacity Module:				
Cnflct Vol:	518 xxxx xxxxx	687 xxxx xxxxx	884 1230 259	968 1237 343
Potent Cap.:	1044 xxxx xxxxx	903 xxxx xxxxx	240 176 740	208 175 653
Move Cap.:	1044 xxxx xxxxx	903 xxxx xxxxx	230 173 740	202 171 653
Volume/Cap:	0.00 xxxx xxxxx	0.02 xxxx xxxxx	0.05 0.01 0.01	0.02 0.01 0.02
Level Of Service Module:				
Queue:	0.0 xxxx xxxxx	0.1 xxxx xxxxx	xxxxx xxxxx xxxxx xxxxx xxxxx xxxxx xxxxx xxxxx	xxxxx xxxxx xxxxx xxxxx xxxxx xxxxx xxxxx xxxxx
Stopped Del:	8.5 xxxx xxxxx	9.1 xxxx xxxxx	xxxxx xxxxx xxxxx xxxxx xxxxx xxxxx xxxxx xxxxx	xxxxx xxxxx xxxxx xxxxx xxxxx xxxxx xxxxx xxxxx
LOS by Move:	A * *	A * *	* * *	* * *
Movement:	LT - LTR - RT	LT - LTR - RT	LT - LTR - RT	LT - LTR - RT
Shared Cap.:	xxxx xxxxx xxxxx	xxxx xxxxx xxxxx	292 xxxxx xxxxx	395 xxxxx
SharedQueue:	0.0 xxxx xxxxx	0.1 xxxx xxxxx	0.2 xxxxx xxxxx	0.2 xxxxx
Shrd StpDel:	8.5 xxxx xxxxx	9.1 xxxx xxxxx	18.2 xxxxx xxxxx	14.6 xxxxx
Shared LOS:	A * *	A * *	C * *	B * *
ApproachDel:	xxxxxx	xxxxxx	18.2	14.6
ApproachLOS:	*	*	C	B

Kittelson & Associates, Inc. - Project # 6743
 Milton-Freewater STA and TSP Update, Milton-Freewater, OR
 2004 Existig Traffic Condition, Weeday AM Peak Hour

Level Of Service Computation Report
 2000 HCM Unsignalized Method (Base Volume Alternative)

Intersection #5 Main Street - OR 11/ 8th Ave

Average Delay (sec/veh): 0.9 Worst Case Level Of Service: C [19.7]

Approach:	North Bound	South Bound	East Bound	West Bound
Movement:	L - T - R	L - T - R	L - T - R	L - T - R
Control:	Uncontrolled	Uncontrolled	Stop Sign	Stop Sign
Rights:	Include	Include	Include	Include
Lanes:	0 1 0 1 0	0 1 0 1 0	0 0 1 0 0	0 0 1 0 0
Volume Module: >> Count Date: 29 Nov 2004 <<				
Base Vol:	8 522 2	3 392 15	25 1 11	2 1 12
Growth Adj:	1.00 1.15 1.00	1.00 1.15 1.00	1.00 1.00 1.00	1.00 1.00 1.00
Initial Bse:	8 600 2	3 451 15	25 1 11	2 1 12
User Adj:	1.00 1.00 1.00	1.00 1.00 1.00	1.00 1.00 1.00	1.00 1.00 1.00
PHF Adj:	0.88 0.88 0.88	0.88 0.88 0.88	0.88 0.88 0.88	0.88 0.88 0.88
PHF Volume:	9 682 2	3 512 17	28 1 13	2 1 14
Reduct Vol:	0 0 0	0 0 0	0 0 0	0 0 0
Final Vol.:	9 682 2	3 512 17	28 1 13	2 1 14
Critical Gap Module:				
Critical Gp:	4.1 xxxx xxxxx	4.1 xxxx xxxxx	7.5 6.5 6.9	7.5 6.5 6.9
FollowUpTim:	2.2 xxxx xxxxx	2.2 xxxx xxxxx	3.5 4.0 3.3	3.5 4.0 3.3
Capacity Module:				
Cnflct Vol:	529 xxxx xxxxx	684 xxxx xxxxx	887 1230 265	965 1238 342
Potent Cap.:	1034 xxxx xxxxx	905 xxxx xxxxx	238 176 734	209 174 654
Move Cap.:	1034 xxxx xxxxx	905 xxxx xxxxx	230 174 734	203 172 654
Volume/Cap:	0.01 xxxx xxxxx	0.00 xxxx xxxxx	0.12 0.01 0.02	0.01 0.01 0.02
Level Of Service Module:				
Queue:	0.0 xxxx xxxxx	0.0 xxxx xxxxx	xxxxx xxxxx xxxxx xxxxx xxxxx xxxxx xxxxx xxxxx	xxxxx xxxxx xxxxx xxxxx xxxxx xxxxx xxxxx xxxxx
Stopped Del:	8.5 xxxx xxxxx	9.0 xxxx xxxxx	xxxxx xxxxx xxxxx xxxxx xxxxx xxxxx xxxxx xxxxx	xxxxx xxxxx xxxxx xxxxx xxxxx xxxxx xxxxx xxxxx
LOS by Move:	A * *	A * *	* * *	* * *
Movement:	LT - LTR - RT	LT - LTR - RT	LT - LTR - RT	LT - LTR - RT
Shared Cap.:	xxxx xxxxx xxxxx	xxxx xxxxx xxxxx	286 xxxxx xxxxx	441 xxxxx
SharedQueue:	0.0 xxxx xxxxx	0.0 xxxx xxxxx	0.5 xxxxx xxxxx	0.1 xxxxx
Shrd StpDel:	8.5 xxxx xxxxx	9.0 xxxx xxxxx	19.7 xxxxx xxxxx	13.5 xxxxx
Shared LOS:	A * *	A * *	C * *	B * *
ApproachDel:	xxxxxx	xxxxxx	19.7	13.5
ApproachLOS:	*	*	C	B

Kittelson & Associates, Inc. - Project # 6743
 Milton-Freewater STA and TSP Update, Milton-Freewater, OR
 2004 Existing Traffic Condition, Weeday AM Peak Hour

Level Of Service Computation Report
 2000 HCM Unsignalized Method (Base Volume Alternative)

 Intersection #6 OR 11/7th Ave - Eastbound

Average Delay (sec/veh): 0.2 Worst Case Level Of Service: C [24.5]

Approach:	North Bound			South Bound			East Bound			West Bound		
Movement:	L	T	R	L	T	R	L	T	R	L	T	R
Control:	Uncontrolled			Uncontrolled			Stop Sign			Stop Sign		
Rights:	Include			Include			Include			Include		
Lanes:	0	1	0	1	0	1	0	0	1	0	0	1

Volume Module:	North Bound			South Bound			East Bound			West Bound		
Base Vol:	2	556	0	0	408	13	7	1	2	0	0	0
Growth Adj:	1.00	1.18	1.00	1.00	1.18	1.00	1.00	1.00	1.00	1.00	1.00	1.00
Initial Bse:	2	656	0	0	481	13	7	1	2	0	0	0
User Adj:	1.00	1.00	1.00	1.00	1.00	1.00	1.00	1.00	1.00	1.00	1.00	1.00
PHF Adj:	0.70	0.70	0.70	0.70	0.70	0.70	0.70	0.70	0.70	0.70	0.70	0.70
PHF Volume:	3	937	0	0	688	19	10	1	3	0	0	0
Reduct Vol:	0	0	0	0	0	0	0	0	0	0	0	0
Final Vol.:	3	937	0	0	688	19	10	1	3	0	0	0

Critical Gap Module:	North Bound			South Bound			East Bound			West Bound		
Critical Gp:	4.1	xxxx	xxxxx	xxxxx	xxxx	xxxxx	6.8	6.5	6.9	xxxxx	xxxx	xxxxx
FollowUpTim:	2.2	xxxx	xxxxx	xxxxx	xxxx	xxxxx	3.5	4.0	3.3	xxxxx	xxxx	xxxxx

Capacity Module:	North Bound			South Bound			East Bound			West Bound		
Cnflct Vol:	706	xxxx	xxxxx	xxxx	xxxx	xxxxx	1171	1640	353	xxxx	xxxx	xxxxx
Potent Cap.:	888	xxxx	xxxxx	xxxx	xxxx	xxxxx	189	101	649	xxxx	xxxx	xxxxx
Move Cap.:	888	xxxx	xxxxx	xxxx	xxxx	xxxxx	188	101	649	xxxx	xxxx	xxxxx
Volume/Cap:	0.00	xxxx	xxxxx	xxxx	xxxx	xxxxx	0.05	0.01	0.00	xxxx	xxxx	xxxxx

Level Of Service Module:	North Bound			South Bound			East Bound			West Bound		
Queue:	0.0	xxxx	xxxxx	xxxxx	xxxx	xxxxx	xxxxx	xxxx	xxxxx	xxxxx	xxxx	xxxxx
Stopped Del:	9.1	xxxx	xxxxx	xxxxx	xxxx	xxxxx	xxxxx	xxxx	xxxxx	xxxxx	xxxx	xxxxx
LOS by Move:	A	*	*	*	*	*	*	*	*	*	*	*
Movement:	LT	LTR	RT	LT	LTR	RT	LT	LTR	RT	LT	LTR	RT
Shared Cap.:	xxxx	xxxx	xxxxx	xxxx	xxxx	xxxxx	199	xxxxx	xxxx	0	xxxxx	xxxxx
Shared Queue:	0.0	xxxx	xxxxx	0.0	xxxx	xxxxx	0.2	xxxxx	xxxx	xxxxx	xxxx	xxxxx
Shrd StpDel:	9.1	xxxx	xxxxx	9.0	xxxx	xxxxx	24.5	xxxxx	xxxx	xxxxx	xxxx	xxxxx
Shared LOS:	A	*	*	A	*	*	C	*	*	*	*	*
ApproachDel:	xxxxxx			xxxxxx			24.5			xxxxxx		
ApproachLOS:	*			*			C			*		

Kittelson & Associates, Inc. - Project # 6743
 Milton-Freewater STA and TSP Update, Milton-Freewater, OR
 2004 Existing Traffic Condition, Weeday AM Peak Hour

Level Of Service Computation Report
 2000 HCM Unsignalized Method (Base Volume Alternative)

 Intersection #7 OR 11/7th Avenue - Westbound

Average Delay (sec/veh): 0.3 Worst Case Level Of Service: B [14.0]

Approach:	North Bound			South Bound			East Bound			West Bound		
Movement:	L	T	R	L	T	R	L	T	R	L	T	R
Control:	Uncontrolled			Uncontrolled			Stop Sign			Stop Sign		
Rights:	Include			Include			Include			Include		
Lanes:	0	1	0	1	0	1	0	0	0	0	0	1

Volume Module:	North Bound			South Bound			East Bound			West Bound		
Base Vol:	0	556	1	7	408	0	0	0	0	2	0	16
Growth Adj:	1.00	1.18	1.00	1.00	1.18	1.00	1.00	1.00	1.00	1.00	1.00	1.00
Initial Bse:	0	656	1	7	481	0	0	0	0	2	0	16
User Adj:	1.00	1.00	1.00	1.00	1.00	1.00	1.00	1.00	1.00	1.00	1.00	1.00
PHF Adj:	0.70	0.70	0.70	0.70	0.70	0.70	0.70	0.70	0.70	0.70	0.70	0.70
PHF Volume:	0	937	1	10	688	0	0	0	0	3	0	23
Reduct Vol:	0	0	0	0	0	0	0	0	0	0	0	0
Final Vol.:	0	937	1	10	688	0	0	0	0	3	0	23

Critical Gap Module:	North Bound			South Bound			East Bound			West Bound		
Critical Gp:	xxxxx	xxxx	xxxxx	4.1	xxxx	xxxxx	xxxxx	xxxx	xxxxx	6.8	xxxx	6.9
FollowUpTim:	xxxxx	xxxx	xxxxx	2.2	xxxx	xxxxx	xxxxx	xxxx	xxxxx	3.5	xxxx	3.3

Capacity Module:	North Bound			South Bound			East Bound			West Bound		
Cnflct Vol:	xxxx	xxxx	xxxxx	939	xxxx	xxxxx	xxxx	xxxx	xxxxx	1302	xxxx	469
Potent Cap.:	xxxx	xxxx	xxxxx	726	xxxx	xxxxx	xxxx	xxxx	xxxxx	155	xxxx	546
Move Cap.:	xxxx	xxxx	xxxxx	726	xxxx	xxxxx	xxxx	xxxx	xxxxx	153	xxxx	546
Volume/Cap:	xxxx	xxxx	xxxxx	0.01	xxxx	xxxxx	xxxx	xxxx	xxxxx	0.02	xxxx	0.04

Level Of Service Module:	North Bound			South Bound			East Bound			West Bound		
Queue:	xxxxx	xxxx	xxxxx	0.0	xxxx	xxxxx	xxxxx	xxxx	xxxxx	xxxxx	xxxx	xxxxx
Stopped Del:	xxxxx	xxxx	xxxxx	10.0	xxxx	xxxxx	xxxxx	xxxx	xxxxx	xxxxx	xxxx	xxxxx
LOS by Move:	*	*	*	B	*	*	*	*	*	*	*	*
Movement:	LT	LTR	RT	LT	LTR	RT	LT	LTR	RT	LT	LTR	RT
Shared Cap.:	xxxx	xxxx	xxxxx	xxxx	xxxx	xxxxx	xxxx	xxxx	xxxxx	xxxx	425	xxxxx
Shared Queue:	0.0	xxxx	xxxxx	0.0	xxxx	xxxxx	xxxx	xxxx	xxxxx	xxxxx	0.2	xxxxx
Shrd StpDel:	9.0	xxxx	xxxxx	10.0	xxxx	xxxxx	xxxx	xxxx	xxxxx	xxxxx	14.0	xxxxx
Shared LOS:	A	*	*	B	*	*	*	*	*	*	B	*
ApproachDel:	xxxxxx			xxxxxx			xxxxxx			14.0		
ApproachLOS:	*			*			*			B		

Kittelson & Associates, Inc. - Project # 6743
Milton-Freewater STA and TSP Update, Milton-Freewater, OR
2004 Existing Traffic Condition, Weeday AM Peak Hour

Level Of Service Computation Report
2000 HCM Unsignalized Method (Base Volume Alternative)

Intersection #8 OR 117 / 4th Avenue

Average Delay (sec/veh): 0.4 Worst Case Level Of Service: D1 (26.2)

Approach: North Bound South Bound East Bound West Bound
Movement: L - T - R L - T - R L - T - R L - T - R

Control: Uncontrolled Uncontrolled Stop Sign Stop Sign
Rights: Include Include Include Include
Lanes: 0 1 0 1 0 0 1 0 1 0 0 0 1 0 0 0 0 1 0 0

Volume Module:
Base Vol: 3 576 1 5 426 1 5 1 1 1 1 1 10
Growth Adj: 1.00 1.15 1.00 1.00 1.15 1.00 1.00 1.00 1.00 1.00 1.00 1.00
Initial Bse: 3 662 1 5 490 1 5 1 1 1 1 10
User Adj: 1.00 1.00 1.00 1.00 1.00 1.00 1.00 1.00 1.00 1.00 1.00 1.00
PHF Adj: 0.78 0.78 0.78 0.78 0.78 0.78 0.78 0.78 0.78 0.78 0.78 0.78
PHF Volume: 4 849 1 6 628 1 6 1 1 1 1 13
Reduct Vol: 0 0 0 0 0 0 0 0 0 0 0 0
Final Vol.: 4 849 1 6 628 1 6 1 1 1 1 13

Critical Gap Module:
Critical Gp: 4.1 xxxx xxxxx 4.1 xxxx xxxxx 7.5 6.5 6.9 7.5 6.5 6.9
FollowUpTim: 2.2 xxxx xxxxx 2.2 xxxx xxxxx 3.5 4.0 3.3 3.5 4.0 3.3

Capacity Module:
Conflict Vol: 629 xxxx xxxxx 851 xxxx xxxxx 1074 1500 315 1185 1500 425
Potent Cap.: 949 xxxx xxxxx 784 xxxx xxxxx 177 123 687 147 123 583
Move Cap.: 949 xxxx xxxxx 784 xxxx xxxxx 170 122 687 144 122 583
Volume/Cap: 0.00 xxxx xxxxx 0.01 xxxx xxxxx 0.04 0.01 0.00 0.01 0.01 0.02

Level Of Service Module:
Queue: 0.0 xxxx xxxxx 0.0 xxxx xxxxx xxxxx xxxxx xxxxx xxxxx xxxxx xxxxx
Stopped Del: 8.8 xxxx xxxxx 9.6 xxxx xxxxx xxxxx xxxxx xxxxx xxxxx xxxxx xxxxx
LOS by Move: A * * A * * A * * A * * A * * A * *
Movement: LT - LTR - RT LT - LTR - RT LT - LTR - RT LT - LTR - RT
Shared Cap.: xxxx xxxx xxxxx xxxx xxxx xxxxx 179 xxxxx xxxxx 371 xxxxx
SharedQueue: 0.0 xxxx xxxxx 0.0 xxxx xxxxx xxxxx 0.2 xxxxx xxxxx 0.1 xxxxx
Shrd StpDel: 8.8 xxxx xxxxx 9.6 xxxx xxxxx xxxxx 26.2 xxxxx xxxxx 15.1 xxxxx
Shared LOS: A * * A * * A * * D * * C * *
ApproachDel: xxxxxx xxxxxx 26.2 15.1
ApproachLOS: * * * D C

Kittelson & Associates, Inc. - Project # 6743
Milton-Freewater STA and TSP Update, Milton-Freewater, OR
2004 Existing Traffic Condition, Weeday AM Peak Hour

Level Of Service Computation Report
2000 HCM Operations Method (Base Volume Alternative)

Intersection #9 Main Street/OR117 / 2nd Ave

Cycle (sec): 100 Critical Vol./Cap. (X): 0.239
Loss Time (sec): 12 (Y+R = 4 sec) Average Delay (sec/veh): 20.4
Optimal Cycle: 29 Level Of Service: C

Approach: North Bound South Bound East Bound West Bound
Movement: L - T - R L - T - R L - T - R L - T - R

Control: Permitted Permitted Split Phase Split Phase
Rights: Ignore Include Include Include
Min. Green: 0 0 0 0 0 0 0 0 0 0 0 0
Lanes: 0 1 1 0 1 0 0 1 1 0 0 0 1 0 1 0 0

Volume Module: >> Count Date: 30 Nov 2004 <<
Base Vol: 14 170 407 0 159 1 7 0 11 262 19 1
Growth Adj: 1.00 1.22 1.22 1.00 1.22 1.00 1.00 1.00 1.00 1.22 1.00 1.00
Initial Bse: 14 207 497 0 194 1 7 0 11 320 19 1
User Adj: 1.00 1.00 0.00 1.00 1.00 1.00 1.00 1.00 1.00 1.00 1.00 1.00
PHF Adj: 0.90 0.90 0.00 0.90 0.90 0.90 0.90 0.90 0.90 0.90 0.90 0.90
PHF Volume: 16 230 0 0 216 1 8 0 12 355 21 1
Reduct Vol: 0 0 0 0 0 0 0 0 0 0 0 0
Reduced Vol: 16 230 0 0 216 1 8 0 12 355 21 1
PCE Adj: 1.00 1.00 0.00 1.00 1.00 1.00 1.00 1.00 1.00 1.00 1.00 1.00
MLF Adj: 1.00 1.00 0.00 1.00 1.00 1.00 1.00 1.00 1.00 1.00 1.00 1.00
Final Vol.: 16 230 0 0 216 1 8 0 12 355 21 1

Saturation Flow Module:
Sat/Lane: 1800 1800 1800 1800 1800 1800 1800 1800 1800 1800 1800 1800
Adjustment: 0.87 0.87 1.00 1.00 0.93 0.93 0.88 1.00 0.88 0.94 0.94 0.94
Lanes: 0.13 1.87 1.00 0.00 1.99 0.01 0.39 0.00 0.61 1.89 0.10 0.01
Final Sat.: 198 2926 1800 0 3331 17 618 0 971 3182 178 9

Capacity Analysis Module:
Vol/Sat: 0.08 0.08 0.00 0.00 0.06 0.06 0.01 0.00 0.01 0.11 0.12 0.12
Crit Moves: ****
Green/Cycle: 0.33 0.33 0.00 0.00 0.33 0.33 0.05 0.00 0.05 0.50 0.50 0.50
Volume/Cap: 0.24 0.24 0.00 0.00 0.20 0.20 0.24 0.00 0.24 0.22 0.24 0.24
Delay/Veh: 24.5 24.5 0.0 0.0 24.1 24.1 46.9 0.0 46.9 14.3 14.4 14.4
User DelAdj: 1.00 1.00 1.00 1.00 1.00 1.00 1.00 1.00 1.00 1.00 1.00 1.00
AdjDel/Veh: 24.5 24.5 0.0 0.0 24.1 24.1 46.9 0.0 46.9 14.3 14.4 14.4
HCM2kAvg: 3 3 0 0 2 2 1 0 1 3 4 4

Kittelson & Associates, Inc. - Project # 6743
Milton-Freewater STA and TSP Update, Milton-Freewater, OR
2004 Existing Traffic Conditions, Weekday PM Peak Hour

Scenario: PM Scenario Report

Command: PM
Volume: PM
Geometry: EX
Impact Fee: Default Impact Fee
Trip Generation: Default Trip Generation
Trip Distribution: Default Trip Distribution
Paths: Default Paths
Routes: Default Routes
Configuration: Default Configuration

Traffix 7.7.1115 (c) 2004 Dowling Assoc. Licensed to KITTELSON, PORTLAND

Kittelson & Associates, Inc. - Project # 6743
Milton-Freewater STA and TSP Update, Milton-Freewater, OR
2004 Existing Traffic Conditions, Weekday PM Peak Hour

Impact Analysis Report
Level Of Service

Intersection	Base		Future		Change in
	Del/ LOS	V/ Veh C	Del/ LOS	V/ Veh C	
# 1 OR 11/ 14th Ave	C	16.3 0.000	C	16.3 0.000	+ 0.000 D/V
# 2 Main Street-OR11/ 12th Ave	D	31.6 0.000	D	31.6 0.000	+ 0.000 D/V
# 3 Main Street - OR 11/ 10th Ave	D	33.1 0.000	D	33.1 0.000	+ 0.000 D/V
# 4 Main Street - OR 11/ 9th Ave	C	24.6 0.000	C	24.6 0.000	+ 0.000 D/V
# 5 Main Street-OR11/ 8th Ave	E	42.0 0.000	E	42.0 0.000	+ 0.000 D/V
# 6 OR 11/7th Ave - Eastbound	D	34.6 0.000	D	34.6 0.000	+ 0.000 D/V
# 7 OR 11/7th Avenue - Westbound	B	12.4 0.000	B	12.4 0.000	+ 0.000 D/V
# 8 OR 11/ 4th Avenue	D	34.8 0.000	D	34.8 0.000	+ 0.000 D/V
# 9 Main Street/OR11/ 2nd Ave	B	19.6 0.345	B	19.6 0.345	+ 0.000 D/V

Traffix 7.7.1115 (c) 2004 Dowling Assoc. Licensed to KITTELSON, PORTLAND

Kittelson & Associates, Inc. - Project # 6743
Milton-Freewater STA and TSP Update, Milton-Freewater, OR
2004 Existing Traffic Conditions, Weekday PM Peak Hour

Level Of Service Computation Report
2000 HCM Unsignalized Method (Base Volume Alternative)

Intersection #1 OR 11/ 14th Ave

Average Delay (sec/veh): 3.4 Worst Case Level Of Service: CI [16.3]

Table with 4 columns: North Bound, South Bound, East Bound, West Bound. Rows include Movement, Control, Rights, and Lanes.

Volume Module: >> Count Date: 1 Dec 2004 <<. Table with 4 columns: North Bound, South Bound, East Bound, West Bound. Rows include Base Vol, Growth Adj, Initial Bse, User Adj, PHF Adj, PHF Volume, Reduct Vol, Final Vol.

Critical Gap Module: Table with 4 columns: North Bound, South Bound, East Bound, West Bound. Rows include Critical Gp, FollowUpTim.

Capacity Module: Table with 4 columns: North Bound, South Bound, East Bound, West Bound. Rows include Conflict Vol, Potent Cap., Move Cap., Volume/Cap.

Level Of Service Module: Table with 4 columns: North Bound, South Bound, East Bound, West Bound. Rows include Queue, Stopped Del, LOS by Move, Movement, Shared Cap., Shared Queue, Shrd StpDel, Shared LOS, ApproachDel, ApproachLOS.

Kittelson & Associates, Inc. - Project # 6743
Milton-Freewater STA and TSP Update, Milton-Freewater, OR
2004 Existing Traffic Conditions, Weekday PM Peak Hour

Level Of Service Computation Report
2000 HCM Unsignalized Method (Base Volume Alternative)

Intersection #2 Main Street-OR11/ 12th Ave

Average Delay (sec/veh): 1.1 Worst Case Level Of Service: DI [31.6]

Table with 4 columns: North Bound, South Bound, East Bound, West Bound. Rows include Movement, Control, Rights, and Lanes.

Volume Module: >> Count Date: 7 Dec 2004 <<. Table with 4 columns: North Bound, South Bound, East Bound, West Bound. Rows include Base Vol, Growth Adj, Initial Bse, User Adj, PHF Adj, PHF Volume, Reduct Vol, Final Vol.

Critical Gap Module: Table with 4 columns: North Bound, South Bound, East Bound, West Bound. Rows include Critical Gp, FollowUpTim.

Capacity Module: Table with 4 columns: North Bound, South Bound, East Bound, West Bound. Rows include Conflict Vol, Potent Cap., Move Cap., Volume/Cap.

Level Of Service Module: Table with 4 columns: North Bound, South Bound, East Bound, West Bound. Rows include Queue, Stopped Del, LOS by Move, Movement, Shared Cap., Shared Queue, Shrd StpDel, Shared LOS, ApproachDel, ApproachLOS.

Kittelston & Associates, Inc. - Project # 6743
Milton-Freewater STA and TSP Update, Milton-Freewater, OR
2004 Existing Traffic Conditions, Weekday PM Peak Hour

Level Of Service Computation Report
2000 HCM Unsignalized Method (Base Volume Alternative)

Intersection #3 Main Street - OR 11/ 10th Ave

Average Delay (sec/veh): 1.1 Worst Case Level Of Service: D [33.1]

Table with 4 columns: North Bound, South Bound, East Bound, West Bound. Rows include Movement, Control, Rights, Lanes, and Volume Module.

Table with 4 columns: North Bound, South Bound, East Bound, West Bound. Rows include Base Vol, Growth Adj, Initial Bse, User Adj, PHF Adj, PHF Volume, and Reduct Vol.

Table with 4 columns: North Bound, South Bound, East Bound, West Bound. Rows include Critical Gap Module and FollowUpTim.

Table with 4 columns: North Bound, South Bound, East Bound, West Bound. Rows include Capacity Module, Conflict Vol, Potent Cap, Move Cap, and Volume/Cap.

Table with 4 columns: North Bound, South Bound, East Bound, West Bound. Rows include Level Of Service Module, Queue, Stopped Del, LOS by Move, Movement, Shared Cap, Shared Queue, Shrd StpDel, Shared LOS, ApproachDel, and ApproachLOS.

Kittelston & Associates, Inc. - Project # 6743
Milton-Freewater STA and TSP Update, Milton-Freewater, OR
2004 Existing Traffic Conditions, Weekday PM Peak Hour

Level Of Service Computation Report
2000 HCM Unsignalized Method (Base Volume Alternative)

Intersection #4 Main Street - OR 11/ 9th Ave

Average Delay (sec/veh): 0.8 Worst Case Level Of Service: C [24.6]

Table with 4 columns: North Bound, South Bound, East Bound, West Bound. Rows include Movement, Control, Rights, Lanes, and Volume Module.

Table with 4 columns: North Bound, South Bound, East Bound, West Bound. Rows include Base Vol, Growth Adj, Initial Bse, User Adj, PHF Adj, PHF Volume, and Reduct Vol.

Table with 4 columns: North Bound, South Bound, East Bound, West Bound. Rows include Critical Gap Module and FollowUpTim.

Table with 4 columns: North Bound, South Bound, East Bound, West Bound. Rows include Capacity Module, Conflict Vol, Potent Cap, Move Cap, and Volume/Cap.

Table with 4 columns: North Bound, South Bound, East Bound, West Bound. Rows include Level Of Service Module, Queue, Stopped Del, LOS by Move, Movement, Shared Cap, Shared Queue, Shrd StpDel, Shared LOS, ApproachDel, and ApproachLOS.

Kittelson & Associates, Inc. - Project # 6743
Milton-Freewater STA and TSP Update, Milton-Freewater, OR
2004 Existing Traffic Conditions, Weekday PM Peak Hour

Level Of Service Computation Report
2000 HCM Unsignalized Method (Base Volume Alternative)

Intersection #5 Main Street-OR11/ 8th Ave

Average Delay (sec/veh): 1.3 Worst Case Level Of Service: E [42.0]

Table with 4 columns: North Bound, South Bound, East Bound, West Bound. Rows include Movement, Control, Rights, and Lanes.

Table with 4 columns: North Bound, South Bound, East Bound, West Bound. Rows include Volume Module, Base Vol, Growth Adj, Initial Bse, User Adj, PHF Adj, PHF Volume, and Reduct Vol.

Table with 4 columns: North Bound, South Bound, East Bound, West Bound. Rows include Critical Gap Module and FollowUpTim.

Table with 4 columns: North Bound, South Bound, East Bound, West Bound. Rows include Capacity Module, Conflict Vol, Potent Cap., Move Cap., and Volume/Cap.

Table with 4 columns: North Bound, South Bound, East Bound, West Bound. Rows include Level Of Service Module, Queue, Stopped Del, LOS by Move, Movement, Shared Cap., Shared Queue, Shrd StpDel, Shared LOS, ApproachDel, and ApproachLOS.

Kittelson & Associates, Inc. - Project # 6743
Milton-Freewater STA and TSP Update, Milton-Freewater, OR
2004 Existing Traffic Conditions, Weekday PM Peak Hour

Level Of Service Computation Report
2000 HCM Unsignalized Method (Base Volume Alternative)

Intersection #6 OR 11/7th Ave Eastbound

Average Delay (sec/veh): 0.9 Worst Case Level Of Service: D [34.6]

Table with 4 columns: North Bound, South Bound, East Bound, West Bound. Rows include Movement, Control, Rights, and Lanes.

Table with 4 columns: North Bound, South Bound, East Bound, West Bound. Rows include Volume Module, Base Vol, Growth Adj, Initial Bse, User Adj, PHF Adj, PHF Volume, and Reduct Vol.

Table with 4 columns: North Bound, South Bound, East Bound, West Bound. Rows include Critical Gap Module and FollowUpTim.

Table with 4 columns: North Bound, South Bound, East Bound, West Bound. Rows include Capacity Module, Conflict Vol, Potent Cap., Move Cap., and Volume/Cap.

Table with 4 columns: North Bound, South Bound, East Bound, West Bound. Rows include Level Of Service Module, Queue, Stopped Del, LOS by Move, Movement, Shared Cap., Shared Queue, Shrd StpDel, Shared LOS, ApproachDel, and ApproachLOS.

Kittelson & Associates, Inc. - Project # 6743
Milton-Freewater STA and TSP Update, Milton-Freewater, OR
2004 Existing Traffic Conditions, Weekday PM Peak Hour

Level Of Service Computation Report
2000 HCM Unsignalized Method (Base Volume Alternative)

Intersection #7 OR 11/7th Avenue - Westbound

Average Delay (sec/veh): 0.2 Worst Case Level Of Service: B [12.4]

Table with 4 columns: North Bound, South Bound, East Bound, West Bound. Rows include Movement (L-T-R), Control, Rights, and Lanes.

Volume Module table with 4 columns: North Bound, South Bound, East Bound, West Bound. Rows include Base Vol, Growth Adj, Initial Bse, User Adj, PHF Adj, PHF Volume, Reduct Vol, and Final Vol.

Critical Gap Module table with 4 columns: North Bound, South Bound, East Bound, West Bound. Rows include Critical Gap and FollowUp Time.

Capacity Module table with 4 columns: North Bound, South Bound, East Bound, West Bound. Rows include Conflict Vol, Potent Cap, Move Cap, and Volume/Cap.

Level Of Service Module table with 4 columns: North Bound, South Bound, East Bound, West Bound. Rows include Queue, Stopped Del, LOS by Move, Movement, Shared Cap, Shared Queue, Shrd StpDel, Shared LOS, ApproachDel, and ApproachLOS.

Kittelson & Associates, Inc. - Project # 6743
Milton-Freewater STA and TSP Update, Milton-Freewater, OR
2004 Existing Traffic Conditions, Weekday PM Peak Hour

Level Of Service Computation Report
2000 HCM Unsignalized Method (Base Volume Alternative)

Intersection #8 OR 11/ 4th Avenue

Average Delay (sec/veh): 0.4 Worst Case Level Of Service: D [34.8]

Table with 4 columns: North Bound, South Bound, East Bound, West Bound. Rows include Movement (L-T-R), Control, Rights, and Lanes.

Volume Module table with 4 columns: North Bound, South Bound, East Bound, West Bound. Rows include Base Vol, Growth Adj, Initial Bse, User Adj, PHF Adj, PHF Volume, Reduct Vol, and Final Vol.

Critical Gap Module table with 4 columns: North Bound, South Bound, East Bound, West Bound. Rows include Critical Gap and FollowUp Time.

Capacity Module table with 4 columns: North Bound, South Bound, East Bound, West Bound. Rows include Conflict Vol, Potent Cap, Move Cap, and Volume/Cap.

Level Of Service Module table with 4 columns: North Bound, South Bound, East Bound, West Bound. Rows include Queue, Stopped Del, LOS by Move, Movement, Shared Cap, Shared Queue, Shrd StpDel, Shared LOS, ApproachDel, and ApproachLOS.

Kittelson & Associates, Inc. - Project # 6743
 Milton-Freewater STA and TSP Update, Milton-Freewater, OR
 2004 Existing Traffic Conditions, Weekday PM Peak Hour

Level Of Service Computation Report
 2000 HCM Operations Method (Base Volume Alternative)

 Intersection #9 Main Street/OR11/ 2nd Ave

Cycle (sec): 100 Critical Vol./Cap. (X): 0.345
 Loss Time (sec): 12 (Y+R = 4 sec) Average Delay (sec/veh): 19.6
 Optimal Cycle: 33 Level Of Service: B

Approach:	North Bound				South Bound				East Bound				West Bound							
Movement:	L	T	R		L	T	R		L	T	R		L	T	R					
Control:	Permitted				Permitted				Split Phase				Split Phase							
Rights:	Ignore				Include				Include				Include							
Min. Green:	0	0	0		0	0	0		0	0	0		0	0	0					
Lanes:	0	1	1	0	1	0	0	1	1	0	0	0	1	0	0	1	0	1	0	0

Volume Module: >> Count Date: 30 Nov 2004 <<

Base Vol:	7	187	398	0	189	12	5	0	9	481	31	6
Growth Adj:	1.00	1.22	1.22	1.00	1.22	1.00	1.00	1.00	1.00	1.22	1.00	1.00
Initial Bse:	7	228	486	0	231	12	5	0	9	587	31	6
User Adj:	1.00	1.00	0.00	1.00	1.00	1.00	1.00	1.00	1.00	1.00	1.00	1.00
PHF Adj:	0.92	0.92	0.00	0.92	0.92	0.92	0.92	0.92	0.92	0.92	0.92	0.92
PHF Volume:	8	248	0	0	251	13	5	0	10	638	34	7
Reduct Vol:	0	0	0	0	0	0	0	0	0	0	0	0
Reduced Vol:	8	248	0	0	251	13	5	0	10	638	34	7
PCE Adj:	1.00	1.00	0.00	1.00	1.00	1.00	1.00	1.00	1.00	1.00	1.00	1.00
MLF Adj:	1.00	1.00	0.00	1.00	1.00	1.00	1.00	1.00	1.00	1.00	1.00	1.00
Final Vol.:	8	248	0	0	251	13	5	0	10	638	34	7

Saturation Flow Module:

Sat/Lane:	1800	1800	1800	1800	1800	1800	1800	1800	1800	1800	1800	1800
Adjustment:	0.88	0.88	1.00	1.00	0.92	0.92	0.88	1.00	0.88	0.93	0.93	0.93
Lanes:	0.06	1.94	1.00	0.00	1.90	0.10	0.36	0.00	0.64	1.89	0.09	0.02
Final Sat.:	94	3073	1800	0	3164	165	565	0	1017	3177	158	31

Capacity Analysis Module:

Vol/Sat:	0.08	0.08	0.00	0.00	0.08	0.08	0.01	0.00	0.01	0.20	0.21	0.21
Crit Moves:	****			****			****			****		
Green/Cycle:	0.23	0.23	0.00	0.00	0.23	0.23	0.03	0.00	0.03	0.62	0.62	0.62
Volume/Cap:	0.35	0.35	0.00	0.00	0.34	0.34	0.35	0.00	0.35	0.32	0.35	0.35
Delay/Veh:	32.2	32.2	0.0	0.0	32.1	32.1	52.4	0.0	52.4	9.2	9.4	9.4
User DelAdj:	1.00	1.00	1.00	1.00	1.00	1.00	1.00	1.00	1.00	1.00	1.00	1.00
AdjDel/Veh:	32.2	32.2	0.0	0.0	32.1	32.1	52.4	0.0	52.4	9.2	9.4	9.4
HCM2kAvg:	4	4	0	0	4	4	1	0	1	5	6	6

Appendix C

Crash Data

TRANSPORTATION DATA SECTION - CRASH ANALYSIS AND REPORTING UNIT
 CONTINUOUS SYSTEM CRASH LISTING
 OR 11 (Route 11, Hwy 8) at SW 12th Avenue in Milton-Freewater
 1999 - 2003

COUNTY CITY URBAN AREA	CLASS		CONN # FIRST STREET SECOND STREET	RD CHAR DIRECT LOCTN	INT-TYP (MEDIAN) LEGS (#LANES)	INT-REL TRAF- CNTL	OFFRD RDNBT DRVWY	WTHR SURF LIGHT	CRASH COLL SVRTY	VEHICLE USE-TRLR OWNER V# TYPE	MOVE FROM TO	PRTC P# TYPE	INJ SVRTY	A S			ERROR	ACT	
	COMPNT MLG TYP MILEPNT													G E X RES	LICNS PED- LOC				
/2000 UMATILLA MILTON-FREEWATER MILT-FRE UA	14			INTER	CROSS														
	0	S	MAIN ST	SW		N	N	CLR	S-1STOP	1	NONE 0	STRGHT							
	0	30.01	SE 12TH AVE	06	0			DRY	REAR		PRVTE SW NE	1	DRV	NONE	50 M	OR-Y		014	000
								DAY	PDO		PSNGR CA					OR<25			
										2	NONE 0	STOP							
											PRVTE SW NE	1	DRV	NONE	40 F	OR-Y		000	012
											PSNGR CA					OR<25			
/2002 UMATILLA MILTON-FREEWATER MILT-FRE UA	14			INTER	CROSS														
	0	S	MAIN ST	CN		N	N	CLR	O-1TURN	1	NONE 0	STRGHT							
	0	30.01	SE 12TH AVE	02	0			DRY	TURN		PRVTE SE NW	1	DRV	NONE	39 M	OR-Y		000	000
								DAY	PDO		PSNGR CA					OR<25			
										2	NONE 0	TURN-L							
											PRVTE NW NE	1	DRV	NONE	45 M	OR-Y		004	000
											PSNGR CA					OR<25			
/2003 UMATILLA MILTON-FREEWATER MILT-FRE UA	14			INTER	CROSS														
	0		MAIN ST	CN		N	N	CLR	O-1TURN	1	NONE 0	STRGHT							
	0	30.01	12TH AVE	02	0			DRY	TURN		PRVTE SE NW	1	DRV	INJB	30 M	OTH-Y		000	000
								DAY	INJ		PSNGR CA					N-RES			
										2	NONE 0	TURN-L							
											PRVTE NW NE	1	DRV	NONE	46 M	OTH-Y		004	000
											PSNGR CA					N-RES			

TRANSPORTATION DATA SECTION - CRASH ANALYSIS AND REPORTING UNIT
CONTINUOUS SYSTEM CRASH LISTING
OR 11 (Route 11, Hwy 8) at SW 11th Avenue in Milton-Freewater
1999 - 2003

COUNTY CITY URBAN AREA	CLASS		RD CHAR DIRECT LOCTN	INT-TYP (MEDIAN) INT-REL LEGS TRAF- (#LANES) CNTL		OFFRD RNDDBT DRVWY	WTHR SURF LIGHT	CRASH COLL SVRTY	VEHICLE USE-TRLR OWNER		MOVE FROM TO	PRTC INJ SVRTY	A S G E LICNS PED E X RES LOC		ERROR	ACT
	COMPNT MLG TYP MILEPNT	CONN # FIRST STREET SECOND STREET		INT-REL TRAF- CNTL	VEHICLE TYPE				VEHICLE TYPE	EX RES			LOC			
/2003 UMATILLA	14		INTER	3-LEG	N	N	CLR	ANGL-OT	1	NONE 0	STRGHT					
MILTON-FREEWATER	0	S MAIN ST	CN		STOP SIGN	N	DRY	TURN		PRVTE	NW SE					001
MILT-FRE UA	0	30.07 SE 11TH AVE	04	0		N	DAY	PDO		PSNGR CA		1	DRV	NONE	87 M OR-Y OR<25	000
										2	NONE 0	TURN-L				011
										PSNGR CA	SW NW	1	DRV	NONE	19 F OR-Y OR<25	028

TRANSPORTATION DATA SECTION - CRASH ANALYSIS AND REPORTING UNIT
 CONTINUOUS SYSTEM CRASH LISTING
 OR 11 (Route 11, Hwy 8) at SW 10th Avenue in Milton-Freewater
 1999 - 2003

COUNTY CITY URBAN AREA	CLASS		RD CHAR DIRECT LOCTN	INT-TYP (MEDIAN) LEGS		INT-REL TRAF- CNTL	OFFRD RNDBT DRVWY	WTHR SURF LIGHT	CRASH COLL SVRTY	VEHICLE		MOVE FROM TO	PRTC INJ SVRTY	A S G E LICNS PED	E X RES LOC	ERROR	ACT
	COMPNT MLG TYP MILEPNT	CONN # FIRST STREET SECOND STREET		VEHICLE USE-TRLR OWNER	V# TYPE												
/2002 UMATILLA	14		INTER	CROSS	N	N	CLR	S-1STOP	1	NONE	0	STRGHT					
MILTON-FREEWATER	0	S MAIN ST	N		NONE	N	DRY	REAR		PRVTE		NW SE					000
MILT-FRE UA	0	30.13 SE 10TH AVE	06	0		N	DAY	PDO		PSNGR	CA		1	DRV	NONE	74 F OR-Y OR>25	043
									2	NONE	0	STOP					
										PRVTE		NW SE					011
										PSNGR	CA		1	DRV	NONE	54 M OTH-Y N-RES	000

TRANSPORTATION DATA SECTION - CRASH ANALYSIS AND REPORTING UNIT
 CONTINUOUS SYSTEM CRASH LISTING
 OR 11 (Route 11, Hwy 8) at SW 5th Avenue in Milton-Freewater
 1999 - 2003

COUNTY	CLASS	CONN #	RD CHAR	INT-TYP	INT-REL	OFFRD	WTHR	CRASH	VEHICLE	MOVE	AS	INJ	GE	PED	ERROR	ACT	
CITY	MLG TYP	FIRST STREET	DIRECT	(MEDIAN)	TRAF-	RNDBT	SURF	COLL	USE-TRLR	FROM	E X	RES	LICNS	LOC			
URBAN AREA	MILEPNT	SECOND STREET	LOCTN	(#LANES)	CNTL	DRVWY	LIGHT	SVRTY	V#	TYPE	TO	P#	TYPE	SVRTY			
/2001 UMATILLA	14		INTER	4-LEG	N	N	CLR	S-1STOP	1	NONE 0	STRGHT						
MILTON-FREEWATER	0	S MAIN ST	NW		NONE	N	DRY	REAR		PRVTE	NW SE					000	
MILT-FRE UA	0 30.50	SW 5TH AVE	06	0		N	DAY	PDO		PSNGR CA		1	DRV	NONE	29 F	OR-Y OR<25	026
									2	NONE 0	STOP						
										PRVTE	NW SE	1	DRV	NONE	26 M	OR-Y OR<25	000
										PSNGR CA							
/2001 UMATILLA	14		INTER	CROSS	N	N	CLR	ANGL-OT	1	NONE 0	STRGHT						
MILTON-FREEWATER	0	S MAIN ST	CN		STOP SIGN	N	DRY	ANGL		PRVTE	SE NW					000	
MILT-FRE UA	0 30.50	SW 5TH AVE	02	0		N	DAY	INJ		PSNGR CA		1	DRV	INJA	22 F	OTH-Y N-RES	000
									2	NONE 0	STRGHT						
										PRVTE	NE SW	1	DRV	NONE	79 M	OR-Y OR>25	021
										PSNGR CA							

TRANSPORTATION DATA SECTION - CRASH ANALYSIS AND REPORTING UNIT
 CONTINUOUS SYSTEM CRASH LISTING
 OR 11 (Route 11, Hwy 8) at SW 4th Avenue in Milton-Freewater
 1999 - 2003

COUNTY CITY URBAN AREA	CLASS		CONN # FIRST STREET SECOND STREET	RD CHAR DIRECT LOCTN	INT-TYP (MEDIAN) LEGS (#LANES)	INT-REL TRAF- CNTL	OFFRD RNDBT DRVWY	WTHR SURF LIGHT	CRASH COLL SVRTY	VEHICLE USE-TRLR OWNER TYPE	MOVE FROM TO	PRTC P#	INJ SVRTY	A S		ERROR	ACT
	COMPNT MLG TYP MILEPNT	MLG TYP MILEPNT												E X	RES		
/1999 UMATILLA MILTON-FREEWATER MILT-FRE UA	14			INTER	CROSS	N	N	CLR	S-1STOP	1 NONE 0	STRGHT						
	0	S MAIN ST		SE		NONE	N	DRY	REAR	PRVTE	SE NW						000
	0	30.55 SW 4TH AVE		06	0		N	DLIT	INJ	PSNGR CA		1	DRV	NONE	43 F OR-Y OR<25	043	
										2 NONE 0	STOP						
										PRVTE	SE NW						011
										PSNGR CA		1	DRV	NONE	51 M OR-Y OR<25	000	
												2	PSN	INJC	13 F		
/1999 UMATILLA MILTON-FREEWATER MILT-FRE UA	14			INTER	CROSS	N	N	CLR	S-1STOP	1 NONE 0	STRGHT						
	0	S MAIN ST		SE		NONE	N	DRY	REAR	PRVTE	SE NW						000
	0	30.55 SE 4TH AVE		06	0		N	DAY	INJ	PSNGR CA		1	DRV	INJC	41 F OR-Y OR>25	047	
										2 NONE 0	STOP						
										PRVTE	SE NW						011
										PSNGR CA		1	DRV	INJC	41 F OR-Y OR<25	000	
/2000 UMATILLA MILTON-FREEWATER MILT-FRE UA	14			INTER	CROSS	N	N	CLR	O-1TURN	1 NONE 0	TURN-L						
	0	S MAIN ST		CN		NONE	N	DRY	TURN	PRVTE	NW NE						000
	0	30.55 SE 4TH AVE		02	0		N	DAY	PDO	PSNGR CA		1	DRV	NONE	25 M N-VAL N-RES	004	
										2 NONE 0	STRGHT						
										PRVTE	SE NW						000
										PSNGR CA		1	DRV	NONE	20 F OR-Y OR<25	000	
/2001 UMATILLA MILTON-FREEWATER MILT-FRE UA	14			INTER	CROSS	N	N	CLD	BIKE								
	0	S MAIN ST		CN		STOP SIGN	N	DRY	TURN								000
	0	30.55 SW 4TH AVE		03	0		N	DAY	INJ								000
											STRGHT						
											NE SW		1	BIK	INJC	48 M	000
										1 NONE 0	TURN-L						
										PRVTE	NW NE						000
										PSNGR CA		1	DRV	NONE	65 M OTH-Y N-RES	027	

TRANSPORTATION DATA SECTION - CRASH ANALYSIS AND REPORTING UNIT
 CONTINUOUS SYSTEM CRASH LISTING
 OR 11 (Route 11, Hwy 8) at SW 3rd Avenue in Milton-Freewater
 1999 - 2003

COUNTY CITY URBAN AREA	CLASS		CONN # FIRST STREET SECOND STREET	RD CHAR DIRECT LOCTN	INT-TYP (MEDIAN) LEGS (#LANES)	INT-REL TRAF- CNTL	OFFRD RNDBT DRVWY	WTHR SURF LIGHT	CRASH COLL SVRTY	VEHICLE USE-TRLR OWNER V# TYPE	MOVE FROM TO	PRTC P#- TYPE	INJ SVRTY	A S G E E X RES	LICNS PED LOC	ERROR	ACT
	COMPNT MLG TYP MILEPNT	STREET															
/2001 UMATILLA	14			INTER	3-LEG	N	N	CLR	ANGL-OT	1	NONE	0	STRGHT				
MILTON-FREEWATER	0	S	MAIN ST	CN		STOP SIGN	N	DRY	TURN		PRVTE	N	S				000
MILT-FRE UA	0	30.59	SW 3RD AVE	03	0		N	DAY	INJ		PSNGR CA	1	DRV	INJC	33	F OR-Y OR<25	000
										2	NONE	0	TURN-L				
											PRVTE	W	N				000
											PSNGR CA	1	DRV	NONE	85	F OR-Y OR<25	021

TRANSPORTATION DATA SECTION - CRASH ANALYSIS AND REPORTING UNIT
 CONTINUOUS SYSTEM CRASH LISTING
 OR 11 (Route 11, Hwy 8) at SW 2nd Avenue in Milton-Freewater
 1999 - 2003

COUNTY CITY URBAN AREA	CLASS COMPNT MLG TYP MILEPNT	CONN # FIRST STREET SECOND STREET	RD CHAR DIRECT LOCTN	INT-TYP (MEDIAN) LEGS (#LANES)	INT-REL TRAF CNTL	OFFRD RNDET DRVWY	WTHR SURF LIGHT	CRASH COLL SVRTY	VEHICLE USE-TRLR OWNER V# TYPE	MOVE FROM TO	PRTC P#	INJ SVRTY	A S G E E X RES	PED LICNS LOC	ERROR	ACT
/1999 UMATILLA MILTON-FREEWATER MILT-FRE UA	14 0	COLUMBIA ST S MAIN ST	INTER NE 06	CROSS 0	N UNKNOWN	N N	CLR DRY DAY	S-STRGH S'S-O INJ	1 NONE 1 PRVTE	STRGHT NE SW	1	DRV NONE	32 M OTH-Y N-RES	045	000	
	2 NONE 0 PRVTE PSNGR CA								STRGHT NE SW	1						DRV INJC
/2002 UMATILLA MILTON-FREEWATER MILT-FRE UA	14 0	COLUMBIA ST S MAIN ST	INTER NE 06	CROSS 0	N TRF SIGNAL	N N	CLR DRY DAY	S-1STOP REAR INJ	1 NONE 0 PRVTE	STRGHT NE SW	1	DRV NONE	67 M OR-Y OR<25	043	000	
	2 NONE 0 PRVTE PSNGR CA								STOP NE SW	1						DRV INJC
/2001 UMATILLA MILTON-FREEWATER MILT-FRE UA	14 0	COLUMBIA ST S MAIN ST	INTER SE 06	CROSS 0	N TRF SIGNAL	N N	CLR DRY DAY	S-1STOP REAR PDO	1 NONE 0 PRVTE	STRGHT SE NW	1	DRV NONE	40 M OR-Y OR>25	026	000	
	2 NONE 0 PRVTE PSNGR CA								STOP SE NW	1						DRV NONE
/2003 UMATILLA MILTON-FREEWATER MILT-FRE UA	14 0	COLUMBIA ST MAIN ST	INTER CN 04	CROSS 0	N TRF SIGNAL	N N	CLD DRY DAY	S-OTHER TURN PDO	1 NONE 1 PRVTE	TURN-L NE SE	1	DRV NONE	68 M OR-Y OR<25	044	000 000	
	2 NONE 0 PRVTE PSNGR CA								TURN-L NE SE	1						DRV NONE

Short Description	Long Description
ACTION	No action or non-warranted
SKIDDED	Skidded
OFF STOP VEH	Getting on or off stopped or parked vehicle
OVHNG STR OBJ	Overhanging load struck another vehicle, etc.
SLWED DOWN	Slowed down
AVOIDING MANV	Avoiding maneuver
PARALLEL PKNG	Parallel parking
ANGLE PKNG	Angle parking
PASSNGR INTERFERED	Passenger interfering with driver
STP IN TRAF/ NO LFT	Stopped in traffic not waiting to make a left turn
STP FOR LFT TURN	Stopped because of left turn signal or waiting, etc.
STP WHILE TURNING	Stopped while executing a turn
PROCEED A/ STOPPING	Proceed after stopping for a stop sign/flashing red.
TURN ON RED	Turned on red after stopping
LOST CONTROL	Lost control of vehicle
ENTR FRM ALLEY/DRWY	Entering street or highway from alley or driveway
ENTR ALLEY FROM RD	Entering alley or driveway from street or highway
BEFORE ENT OBJ BF/ENT	Before entering roadway, struck pedestrian, etc. on sidewalk or shoulder
UNDRIVERLESS VEHICLE	Car ran away - no driver
STRUCK OBJ PRIOR COL	Struck, or was struck by, vehicle or pedestrian in prior collision before acc. stabiliz
VEHICLE STALLED	Vehicle stalled
DEAD BY UNASSOCIATED CAUSE	Dead by unassociated cause
FATIGUED, SLEEPY, ASLEEP	Fatigued, sleepy, asleep
BLINDED BY SUN	Driver blinded by sun
BLINDED BY HEADLIGHTS	Driver blinded by headlights
PHYSICALLY ILL	Physically ill
CROSSED OVER MEDIAN	Vehicle crossed, plunged over, or through median barrier
PURSUING OTHER VEH	Pursuing or attempting to stop another vehicle
PASSING SITUATION	Passing situation
VEHICLE PARKED BEYOND CURB OR SHOULDER	Vehicle parked beyond curb or shoulder
CROSSED MEDIAN	Vehicle crossed earth or grass median
CROSSING AT INTERSECTION - NO TRAFFIC SIGNAL PRESENT	Crossing at intersection - no traffic signal present
CROSSING AT INTERSECTION - TRAFFIC SIGNAL PRESENT	Crossing at intersection - traffic signal present
CROSSING AT INTERSECTION - DIAGONALLY	Crossing at intersection - diagonally
CROSSING BETWEEN INTERSECTIONS	Crossing between intersections
DRIVER'S ATTENTION DISTRACTED	Driver's attention distracted
WALKING, RUNNING, RIDING, ETC., ON SHOULDER WITH TRAFFIC	Walking, running, riding, etc., on shoulder WITH traffic
WALKING, RUNNING, RIDING, ETC., ON SHOULDER FACING TRAFFIC	Walking, running, riding, etc., on shoulder FACING traffic
WALKING, RUNNING, RIDING, ETC., ON PAVEMENT WITH TRAFFIC	Walking, running, riding, etc., on pavement WITH traffic
WALKING, RUNNING, RIDING, ETC., ON PAVEMENT FACING TRAFFIC	Walking, running, riding, etc., on pavement FACING traffic
PLAYING IN STREET OR ROAD	Playing in street or road
PUSHING OR WORKING ON VEHICLE IN ROAD OR ON SHOULDER	Pushing or working on vehicle in road or on shoulder
WORKING IN ROADWAY OR ALONG SHOULDER	Working in roadway or along shoulder
STANDING OR LYING IN ROADWAY	Standing or lying in roadway
ENTERING / STARTING IN TRAFFIC LANE FROM OFF-ROAD	Entering / starting in traffic lane from off-road
OTHER ACTION	Other action
UNKNOWN ACTION	Unknown action

Short Description	Long Description
NOT APPLICABLE	No cause associated at this level
TOO FAST FOR CONDITIONS	Speed too fast for conditions
NO YIELD ROW	Did not yield right-of-way
NO STOP SIGN	Passed stop sign or red flasher
NO R-A-G	Disregarded R-A-G traffic signal.
WRONG SIDE	Drove left of center on two-way road
IMPROPER PASSING	Improper overtaking
FOLLOWING TOO CLOSE	Followed too closely
IMPROPER TURN	Made improper turn
DRUGS	Alcohol or Drug Involved
OTHER DRIVE ERR	Other improper driving
MECHANICAL DEFECT	Mechanical defect
OTHER	Other (not improper driving)
IMPROPER CHANGE	Improper change of traffic lanes
IMPROPER PARKING	Vehicle improperly parked
DEFECTIVE STEERING	Defective steering mechanism
DEFECTIVE BRAKES	Inadequate or no brakes
SHIFTED	Vehicle lost load or load shifted
TIRE FAILURE	Tire Failure
PHANTOM VEHICLE	Phantom / Non-contact Vehicle
INATTENTION	Inattention

Item Description	Long Description
ERROR	No error
WIDE TURN	Wide turn
CUT CORNER	Cut corner on turn
BEY TRN	Failed to obey mandatory traffic turn signal, sign or lane markings
LN FNT TRAF	Left turn in front of oncoming traffic
LN PROHIB	Left turn where prohibited
WRNG LN	Turned from wrong lane
WRONG LN	Turned into wrong lane
U-TURN	U-turned illegally
STOP	Improperly stopped in traffic lane
FAIL SIG	Improper signal or failure to signal
BACKING	Backing improperly (Not parking)
PARKED	Improperly parked
STRT PARK	Improper start leaving parked position
STRT STOP	Improper start from stopped position
NO LIGHTS	Improper or no lights (vehicle in traffic)
DIM LIGHTS	Failed to dim lights (until 4/1/97) / Inattention (after 4/1/97)
UNSAFE VEH	Driving unsafe vehicle (no other error apparent)
MAN N/CLR	Entering, exiting parked position with insufficient clearance or other improper parking maneuver
DR SIG	Disregarded other driver's signal
TRF SIG	Disregarded traffic signal
STP SGN	Disregarded stop sign or flashing red
WRN SGN	Disregarded warning sign, flares or flashing amber
POL/FLG	Disregarded police officer or flagman
SIR/EMR	Disregarded siren or warning of emergency vehicle
RR SIG	Disregarded RR signal, RR sign, or RR flagman
VOID STP V	Failed to avoid stopped or parked vehicle ahead other than school bus
LD ROW BIK	Did not have right-of-way over pedalcyclist
R-O-W	Did not have right-of-way
LD ROW PED	Failed to yield right-of-way to pedestrian
SS ON CURVE	Passing on a curve
SS WRNG SID	Passing on the wrong side
SS TANGENT	Passing on straight road under unsafe conditions
SS STP4PED	Passed vehicle stopped at crosswalk for pedestrian
SS AT INTER	Passing at intersection
SS ON HILL	Passing on crest of hill
SS N/PASSNG	Passing in "No Passing" zone
SS ONC TRAF	Passing in front of oncoming traffic
CUTTING IN	Cutting in (two lanes - two way only)
WRONG SIDE	Driving on wrong side of the road
THRU MEDN	Driving through safety zone or over island
TP SCHLBUS	Failed to stop for school bus

.LW TO CLOS	Following too closely (Must be on Officer's Report)
RD/DR WRNG	Straddling or driving on wrong lanes
'LANE CHG	Improper change of traffic lanes
NG WY/1 WA	Wrong way on one-way roadway (Vehicle is deliberately traveling on wrong side)
ASIC RULE	Driving too fast for conditions (Not excessive speed)
↓ DOOR TRAF	Opened door into adjacent traffic lane
AIN'T SPEED	Citation issued for "Failure to maintain reasonable speed"
EXCESSIVE	Excessive Speed
CKLESS DRVN	Reckless driving
RELSS DRVN	Careless driving
IT NO SGNL	Crossing at intersection -- no traffic signal present
IT W/ SGNL	Crossing at intersection -- traffic signal present
IT DIAGNL	Crossing at intersection - diagonally
TWN INTER	Crossing between intersections
SHLD W/TRAF	Walking, running, riding, etc., on shoulder WITH traffic
SHLD A/TRAF	Walking, running, riding, etc., on shoulder FACING traffic
SHAVE W/TRAF	Walking, running, riding, etc., on pavement WITH traffic
SHAVE A/TRAF	Walking, running, riding, etc., on pavement FACING traffic
PLAY IN RDWY	Playing in street or road
SH MV IN RD	Pushing or working on vehicle in road or on shoulder
WK IN RD	Working in roadway or along shoulder
STND IN RD	Standing or lying in roadway
DISREG POL/FLG	Disregarding Police (eluding)
FAILED LANE	Failed to maintain lane
RAN OFF RD	Ran off road
MISJUDGE CLR	Driver misjudged clearance
OVERCORRECT	Over Correcting
INATTENTION	Inattention (4/1/1997)
OVERLOAD	Overloading or improper loading of vehicle with cargo or passengers
UNABLE DETERM DISRG TCD	Unable to determine which driver disregarded traffic control device

Medium Description	Long Description
ILL/JUMPED MV	Occupant fell, jumped or was ejected from moving vehicle
INGR INTERFERED	Passenger interfered with driver
IML INTERFERED	Animal or insect in vehicle interfered with driver
ED INVOLVED	Pedestrian involved (Non-pedestrian accident)
IBSEQUENT PED	"Sub-Ped": pedestrian injured subsequent to collision, etc.
EDALCYCLE INV	Tricycle-Bicycle involved
TCHHIKER	Hitchhiker (soliciting a ride)
INGR TOWED	Passenger being towed or pushed on conveyance
WOFF STOP VEH	Getting on or off stopped or-parked vehicle (occupants only)
IBSEQ OVERTURN	Overtuned after first harmful event
EH BEING PUSHED	Vehicle being pushed
EH TOWED/TOWING	Vehicle towed or had been towing another vehicle
ORCED BY IMPACT	Vehicle forced by impact into another vehicle, pedalcyclist or pedestrian
/ SET IN MOTION	Vehicle set in motion by non-driver (child released brakes, etc.)
ILROAD ROW	At or on railroad right-of-way (not Light Rail)
3HT RAIL ROW	At or on Light-Rail right-of-way
AIN HIT VEH	Train struck vehicle
EH HIT TRAIN	Vehicle struck train
EH HIT RR CAR	Vehicle struck railroad car on roadway
CKKNIFE	Jackknife; trailer or towed vehicle struck towing vehicle
AILER O'TURN	Trailer or towed vehicle overturned
ILR CONN BROKE	Trailer connection broke
ETCHD TRLR STRKNG	Detached trailing object struck other vehicle, non-motorist, or object
DOOR OPN IN TRAF	Vehicle door opened into adjacent traffic lane
HEEL CAME OFF	Wheel came off
OOD FLEW UP	Hood flew up
OAD SHIFTED	Lost load, load moved or shifted
RE FAILURE	Tire Failure
ET	Pet: cat, dog and similar
/ESTOCK	Stock: cow, calf, bull, steer, sheep, etc.
ORSE	Horse, mule, or donkey
ORSE & RIDER	Horse and rider
AME NO DEER/ELK	Wild animal, game (includes birds; not deer or elk)
ER OR ELK	Deer or elk, wapiti
IIMAL-DRAWN VEH	Animal-drawn vehicle
ILVERT/MANHOLE	Culvert, open low or high manhole
PACT CUSHION	Impact attenuator
ARKING METER	Parking meter
JRB	Curb (also narrow sidewalks on bridges)
3GLE BAR N/MED	Jiggle bars or traffic snake for channelization

JARDRAIL	Guard rail (not metal median barrier)
EDIAN BARRIER	Median barrier (raised or metal)
ALL	Retaining wall or tunnel wall
RIDGE RAIL	Bridge railing (on bridge and approach)
RIDGE ABUTMENT	Bridge abutment (approach ends)
RIDGE COLUMN	Bridge pillar or column (even though struck protective guard rail first)
RIDGE GIRDER	Bridge girder (horizontal structure overhead)
AFFIC ISLAND	Traffic raised island
ORE	Gore
OLE-UNKNOWN	Pole – type unknown
OLE-UTILITY	Pole – power or telephone
OLE-ST LIGHT	Pole – street light only
OLE-TRAF SIGNAL	Pole – traffic signal and ped signal only
OLE-SIGN BRIDGE	Pole – sign bridge
OP/YIELD SIGN	Stop or yield sign
HER SIGN	Other sign, including street signs
DRANT	Hydrant
ELINEATOR	Delineator or marker (reflector posts)
AILBOX	Mailbox
EE/STUMP	Tree, stump or shrubs
GTN OVER RDWY	Tree branch or other vegetation overhead, etc.
BLE ACROSS RD	Wire or cable across or over the road
MP SIGN/BARR	Temporary sign or barricade in road, etc.
RM SIGN/BARR	Permanent sign or barricade in/off road
IDE/ROCKS	Slides, rocks off or on road, falling rocks
REIGN OBJECT	Foreign obstruction/debris in road (not gravel)
UIP WORKING	Equipment working in/off road
HER EQUIPMENT	Other equipment in or off road (includes parked trailer, boat)
AINTNGE EQUIP	Wrecker, street sweeper, snow plow or sanding equipment
HER WALL	Rock, brick or other solid wall
REGULAR PAVEMENT	Speed bump, other bump, pothold or pavement irregularity
VE IN	Bridge or road cave in
GH WATER	High Water
OW BANK	Snow Bank
OLE/RDWY EDGE	Chuckhole in road, low or high shoulder at pavement edge
JT SLOPE/DITCH	Cut slope or ditch embankment
BJ FRM OTHR VEH	Struck by rock or other object set in motion by other vehicle (incl. lost loads)
HER MOVING OBJ	Struck by other moving or flying object
OH OBSCURE VIEW	Vehicle obscured view
OG OBSCURE VIEW	Vegetation obscured view
OD OBSCURE VIEW	View obscured by fence, sign, phone booth, etc.
ND GUST	Wind Gust
MERSION	Vehicle immersed in body of water
RE/EXPLOSION	Fire or Explosion

OTHER	Accidents related to another separate accident
VO WAY ONE SIDE	Two-way traffic on divided roadway all routed to one side
PHANTOM VEH	Other (phantom) non-contact vehicle (on PAR or report)
CELLPHONE-POLICE	Cell phone (on PAR or driver in use)
ADJL GRAD DR LIC	Teenage driver in violation of graduated license pgm
GUY WIRE	Guy wire
BERM	Berm (earthen or gravel mound)
GRAVEL IN RDWY	Gravel in roadway
ABRUPT EDGE	Abrupt edge
CELLPHONE-WITNSS	Cell Phone use witnessed by other participant
UNK FIX OBJ	Unknown type of fixed object
OTHER OBJ NOT FIXED	Other or unknown object, not fixed
PASNGR OUTSIDE VEHICLE	Passenger riding on vehicle exterior
PASNGR ON PEDALCYCLE	Passenger riding on pedalcycle
PEDESTRIAN IN NON-MOTORIZED WHEELCHAIR	Pedestrian in non-motorized wheelchair
PEDESTRIAN IN MOTORIZED WHEELCHAIR	Pedestrian in motorized wheelchair
NON-MOTORIST STRUCK VEH	Non-motorist struck vehicle
STREET CAR/TROLLEY STRUCK VEH	Street Car/Trolley (on rails and/or overhead wire system) struck vehicle
VEHICLE STRUCK STREET CAR/TROLLEY	Vehicle struck Street Car/Trolley (on rails and/or overhead wire system)
AT OR ON STREET CAR/TROLLEY RIGHT-OF-WAY	At or on Street Car/Trolley right-of-way
SHOULDER GAVE WAY	Shoulder gave way

Appendix D

**2025 PM Peak No-Build
Traffic Operations Analysis
Worksheets**

Kittelston & Associates, Inc. - Project # 6743
Milton-Freewater STA and TSP Update, Milton-Freewater, OR
2025 Future Traffic Condition, Weeday AM Peak Hour

Scenario Report

Scenario: AM
Command: AM
Volume: AM
Geometry: EX
Impact Fee: Default Impact Fee
Trip Generation: Default Trip Generation
Trip Distribution: Default Trip Distribution
Paths: Default Paths
Routes: Default Routes
Configuration: Default Configuration

Kittelston & Associates, Inc. - Project # 6743
Milton-Freewater STA and TSP Update, Milton-Freewater, OR
2025 Future Traffic Condition, Weeday AM Peak Hour

Impact Analysis Report
Level Of Service

Intersection	Base		Future		Change in
	LOS	Del/Veh C	LOS	Del/Veh C	
# 1 OR 11/ 14th Ave	D	30.7 0.000	D	30.7 0.000	+ 0.000 D/V
# 2 Main Street-OR11/ 12th Ave	F	51.9 0.000	F	51.9 0.000	+ 0.000 D/V
# 3 Main Street - OR 11/ 10th Ave	C	23.3 0.000	C	23.3 0.000	+ 0.000 D/V
# 4 Main Street - OR 11/ 9th Ave	D	28.0 0.000	D	28.0 0.000	+ 0.000 D/V
# 5 Main Street-OR11/ 8th Ave	D	33.9 0.000	D	33.9 0.000	+ 0.000 D/V
# 6 OR 11/7th Ave - Eastbound	E	44.1 0.000	E	44.1 0.000	+ 0.000 D/V
# 7 OR 11/7th Avenue - Westbound	C	18.9 0.000	C	18.9 0.000	+ 0.000 D/V
# 8 OR 11/ 4th Avenue	E	47.4 0.000	E	47.4 0.000	+ 0.000 D/V
# 9 Main Street/OR11/ 2nd Ave	C	21.1 0.316	C	21.1 0.316	+ 0.000 D/V

Kittelson & Associates, Inc. - Project # 6743
Milton-Freewater STA and TSP Update, Milton-Freewater, OR
2025 Future Traffic Condition, Weeday AM Peak Hour

Level Of Service Computation Report
2000 HCM Unsignalized Method (Base Volume Alternative)

Intersection #1 OR 11/ 14th Ave

Average Delay (sec/veh): 6.3 Worst Case Level Of Service: D [30.7]

Table with columns: Approach, Movement, Control, Rights, Lanes, Volume Module, Base Vol, Growth Adj, Initial Bse, User Adj, PHF Adj, PHF Volume, Reduct Vol, Final Vol. Rows for North, South, East, West bounds.

Critical Gap Module: Critical Gp, FollowUpTim

Capacity Module: Cnflct Vol, Potent Cap., Move Cap., Volume/Cap.

Level Of Service Module: Queue, Stopped Del, LOS by Move, Movement, Shared Cap., Shared Queue, Shrd StpDel, Shared LOS, Approach Del, Approach LOS

Kittelson & Associates, Inc. - Project # 6743
Milton-Freewater STA and TSP Update, Milton-Freewater, OR
2025 Future Traffic Condition, Weeday AM Peak Hour

Level Of Service Computation Report
2000 HCM Unsignalized Method (Base Volume Alternative)

Intersection #2 Main Street-OR11/ 12th Ave

Average Delay (sec/veh): 2.7 Worst Case Level Of Service: F [51.9]

Table with columns: Approach, Movement, Control, Rights, Lanes, Volume Module, Base Vol, Growth Adj, Initial Bse, User Adj, PHF Adj, PHF Volume, Reduct Vol, Final Vol. Rows for North, South, East, West bounds.

Critical Gap Module: Critical Gp, FollowUpTim

Capacity Module: Cnflct Vol, Potent Cap., Move Cap., Volume/Cap.

Level Of Service Module: Queue, Stopped Del, LOS by Move, Movement, Shared Cap., Shared Queue, Shrd StpDel, Shared LOS, Approach Del, Approach LOS

Kittelson & Associates, Inc. - Project # 6743
Milton-Freewater STA and TSP Update, Milton-Freewater, OR
2025 Future Traffic Condition, Weeday AM Peak Hour

Level Of Service Computation Report
2000 HCM Unsignalized Method (Base Volume Alternative)

Intersection #3 Main Street - OR 11/ 10th Ave

Average Delay (sec/veh): 0.6 Worst Case Level Of Service: C [23.3]

Table with 4 columns: North Bound, South Bound, East Bound, West Bound. Rows include Approach, Movement, Control, Rights, and Lanes.

Volume Module: >> Count Date: 18 Nov 2004 <<. Table with 4 columns and 10 rows of traffic volume data.

Critical Gap Module: Table with 4 columns and 2 rows of critical gap and follow-up time data.

Capacity Module: Table with 4 columns and 4 rows of capacity and volume/capacity data.

Level Of Service Module: Table with 4 columns and 10 rows of queue, delay, and LOS data.

Kittelson & Associates, Inc. - Project # 6743
Milton-Freewater STA and TSP Update, Milton-Freewater, OR
2025 Future Traffic Condition, Weeday AM Peak Hour

Level Of Service Computation Report
2000 HCM Unsignalized Method (Base Volume Alternative)

Intersection #4 Main Street - OR 11/ 9th Ave

Average Delay (sec/veh): 0.9 Worst Case Level Of Service: D [28.0]

Table with 4 columns: North Bound, South Bound, East Bound, West Bound. Rows include Approach, Movement, Control, Rights, and Lanes.

Volume Module: >> Count Date: 22 Dec 2004 <<. Table with 4 columns and 10 rows of traffic volume data.

Critical Gap Module: Table with 4 columns and 2 rows of critical gap and follow-up time data.

Capacity Module: Table with 4 columns and 4 rows of capacity and volume/capacity data.

Level Of Service Module: Table with 4 columns and 10 rows of queue, delay, and LOS data.

Kittelson & Associates, Inc. - Project # 6743
Milton-Freewater STA and TSP Update, Milton-Freewater, OR
2025 Future Traffic Condition, Weeday AM Peak Hour

Level Of Service Computation Report
2000 HCM Unsignalized Method (Base Volume Alternative)

Intersection #5 Main Street-OR11/ 8th Ave

Average Delay (sec/veh): 1.4 Worst Case Level Of Service: D [33.9]

Table with columns for Approach (North, South, East, West Bound) and Movement (L, T, R). Rows include Control, Rights, Lanes, Volume Module, Base Vol, Growth Adj, Initial Bse, User Adj, PHF Adj, PHF Volume, Reduct Vol, and Final Vol.

Critical Gap Module: Table with columns for Critical Gp and FollowUpTim.

Capacity Module: Table with columns for Conflict Vol, Potent Cap, Move Cap, and Volume/Cap.

Level Of Service Module: Table with columns for Queue, Stopped Del, LOS by Move, Movement, Shared Cap, Shared Queue, Shrd StpDel, Shared LOS, ApproachDel, and ApproachLOS.

Kittelson & Associates, Inc. - Project # 6743
Milton-Freewater STA and TSP Update, Milton-Freewater, OR
2025 Future Traffic Condition, Weeday AM Peak Hour

Level Of Service Computation Report
2000 HCM Unsignalized Method (Base Volume Alternative)

Intersection #6 OR 11/7th Ave - Eastbound

Average Delay (sec/veh): 0.4 Worst Case Level Of Service: E [44.1]

Table with columns for Approach (North, South, East, West Bound) and Movement (L, T, R). Rows include Control, Rights, Lanes, Volume Module, Base Vol, Growth Adj, Initial Bse, User Adj, PHF Adj, PHF Volume, Reduct Vol, and Final Vol.

Critical Gap Module: Table with columns for Critical Gp and FollowUpTim.

Capacity Module: Table with columns for Conflict Vol, Potent Cap, Move Cap, and Volume/Cap.

Level Of Service Module: Table with columns for Queue, Stopped Del, LOS by Move, Movement, Shared Cap, Shared Queue, Shrd StpDel, Shared LOS, ApproachDel, and ApproachLOS.

Kittelson & Associates, Inc. - Project # 6743
Milton-Freewater STA and TSP Update, Milton-Freewater, OR
2025 Future Traffic Condition, Weeday AM Peak Hour

Level Of Service Computation Report
2000 HCM Unsignalized Method (Base Volume Alternative)

Intersection #7 OR 11/7th Avenue - Westbound

Average Delay (sec/veh): 0.4 Worst Case Level Of Service: C [18.9]

Table with 4 columns: North Bound, South Bound, East Bound, West Bound. Rows include Approach, Movement, Control, Rights, and Lanes.

Volume Module table with 4 columns: North Bound, South Bound, East Bound, West Bound. Rows include Base Vol, Growth Adj, Initial Bse, User Adj, PHF Adj, PHF Volume, Reduct Vol, and Final Vol.

Critical Gap Module table with 4 columns: North Bound, South Bound, East Bound, West Bound. Rows include Critical Gap and FollowUpTim.

Capacity Module table with 4 columns: North Bound, South Bound, East Bound, West Bound. Rows include Conflict Vol, Potent Cap, Move Cap, and Volume/Cap.

Level Of Service Module table with 4 columns: North Bound, South Bound, East Bound, West Bound. Rows include Queue, Stopped Del, LOS by Move, Movement, Shared Cap, Shared Queue, Shrd StpDel, Shared LOS, ApproachDel, and ApproachLOS.

Kittelson & Associates, Inc. - Project # 6743
Milton-Freewater STA and TSP Update, Milton-Freewater, OR
2025 Future Traffic Condition, Weeday AM Peak Hour

Level Of Service Computation Report
2000 HCM Unsignalized Method (Base Volume Alternative)

Intersection #8 OR 11/ 4th Avenue

Average Delay (sec/veh): 0.6 Worst Case Level Of Service: E [47.4]

Table with 4 columns: North Bound, South Bound, East Bound, West Bound. Rows include Approach, Movement, Control, Rights, and Lanes.

Volume Module table with 4 columns: North Bound, South Bound, East Bound, West Bound. Rows include Base Vol, Growth Adj, Initial Bse, User Adj, PHF Adj, PHF Volume, Reduct Vol, and Final Vol.

Critical Gap Module table with 4 columns: North Bound, South Bound, East Bound, West Bound. Rows include Critical Gap and FollowUpTim.

Capacity Module table with 4 columns: North Bound, South Bound, East Bound, West Bound. Rows include Conflict Vol, Potent Cap, Move Cap, and Volume/Cap.

Level Of Service Module table with 4 columns: North Bound, South Bound, East Bound, West Bound. Rows include Queue, Stopped Del, LOS by Move, Movement, Shared Cap, Shared Queue, Shrd StpDel, Shared LOS, ApproachDel, and ApproachLOS.

Kittelson & Associates, Inc. - Project # 6743
 Milton-Freewater STA and TSP Update, Milton-Freewater, OR
 2025 Future Traffic Condition, Weeday AM Peak Hour

Level Of Service Computation Report
 2000 HCM Operations Method (Base Volume Alternative)

 Intersection #9 Main Street/OR11/ 2nd Ave

Cycle (sec): 100 Critical Vol./Cap. (X): 0.316
 Loss Time (sec): 12 (Y+R = 4 sec) Average Delay (sec/veh): 21.1
 Optimal Cycle: 32 Level Of Service: C

Approach:	North Bound			South Bound			East Bound			West Bound		
Movement:	L	T	R	L	T	R	L	T	R	L	T	R
Control:	Permitted			Permitted			Split Phase			Split Phase		
Rights:	Ignore			Include			Include			Include		
Min. Green:	0	0	0	0	0	0	0	0	0	0	0	0
Lanes:	0	1	1	0	0	1	0	0	1	1	0	1

Volume Module: >> Count Date: 30 Nov 2004 <<

Base Vol:	14	170	407	0	159	1	7	0	11	262	19	1
Growth Adj:	1.32	1.61	1.61	1.32	1.61	1.32	1.32	1.32	1.32	1.61	1.32	1.32
Initial Bse:	18	274	655	0	256	1	9	0	15	422	25	1
User Adj:	1.00	1.00	0.00	1.00	1.00	1.00	1.00	1.00	1.00	1.00	1.00	1.00
PHF Adj:	0.90	0.90	0.00	0.90	0.90	0.90	0.90	0.90	0.90	0.90	0.90	0.90
PHF Volume:	21	304	0	0	285	1	10	0	16	469	28	1
Reduct Vol:	0	0	0	0	0	0	0	0	0	0	0	0
Reduced Vol:	21	304	0	0	285	1	10	0	16	469	28	1
PCE Adj:	1.00	1.00	0.00	1.00	1.00	1.00	1.00	1.00	1.00	1.00	1.00	1.00
MLF Adj:	1.00	1.00	0.00	1.00	1.00	1.00	1.00	1.00	1.00	1.00	1.00	1.00
Final Vol.:	21	304	0	0	285	1	10	0	16	469	28	1

Saturation Flow Module:

Sat/Lane:	1800	1800	1800	1800	1800	1800	1800	1800	1800	1800	1800	1800
Adjustment:	0.86	0.86	1.00	1.00	0.93	0.93	0.88	1.00	0.88	0.94	0.94	0.94
Lanes:	0.13	1.87	1.00	0.00	1.99	0.01	0.39	0.00	0.61	1.89	0.10	0.01
Final Sat.:	196	2898	1800	0	3331	17	618	0	971	3182	178	9

Capacity Analysis Module:

Vol/Sat:	0.10	0.10	0.00	0.00	0.09	0.09	0.02	0.00	0.02	0.15	0.16	0.16
Crit Moves:	****			****			****			****		
Green/Cycle:	0.33	0.33	0.00	0.00	0.33	0.33	0.05	0.00	0.05	0.50	0.50	0.50
Volume/Cap:	0.32	0.32	0.00	0.00	0.26	0.26	0.32	0.00	0.32	0.30	0.32	0.32
Delay/Veh:	25.1	25.1	0.0	0.0	24.5	24.5	47.8	0.0	47.8	15.0	15.2	15.2
User DelAdj:	1.00	1.00	1.00	1.00	1.00	1.00	1.00	1.00	1.00	1.00	1.00	1.00
AdjDel/Veh:	25.1	25.1	0.0	0.0	24.5	24.5	47.8	0.0	47.8	15.0	15.2	15.2
HCM2k Avg:	4	4	0	0	3	3	1	0	1	5	5	5

Kittelson & Associates, Inc. - Project # 6743
Milton-Freewater STA and TSP Update, Milton-Freewater, OR
2025 Total Traffic Conditions, Weekday PM Peak Hour

Scenario Report

Scenario: PM
Command: PM
Volume: PM
Geometry: EX
Impact Fee: Default Impact Fee
Trip Generation: Default Trip Generation
Trip Distribution: Default Trip Distribution
Paths: Default Paths
Routes: Default Routes
Configuration: Default Configuration

Kittelson & Associates, Inc. - Project # 6743
Milton-Freewater STA and TSP Update, Milton-Freewater, OR
2025 Total Traffic Conditions, Weekday PM Peak Hour

Impact Analysis Report
Level Of Service

Intersection	Base		Future		Change in
	Del/ LOS	V/ C	Del/ LOS	V/ C	
# 1 OR 11/ 14th Ave	D	27.5 0.000	D	27.5 0.000	+ 0.000 D/V
# 2 Main Street-OR11/ 12th Ave	F	73.7 0.000	F	73.7 0.000	+ 0.000 D/V
# 3 Main Street - OR 11/ 10th Ave	F	88.3 0.000	F	88.3 0.000	+ 0.000 D/V
# 4 Main Street - OR 11/ 9th Ave	E	46.7 0.000	E	46.7 0.000	+ 0.000 D/V
# 5 Main Street-OR11/ 8th Ave	F	162.9 0.000	F	162.9 0.000	+ 0.000 D/V
# 6 OR 11/7th Ave - Eastbound	F	102.4 0.000	F	102.4 0.000	+ 0.000 D/V
# 7 OR 11/7th Avenue - Westbound	C	15.4 0.000	C	15.4 0.000	+ 0.000 D/V
# 8 OR 11/ 4th Avenue	F	74.5 0.000	F	74.5 0.000	+ 0.000 D/V
# 9 Main Street/OR11/ 2nd Ave	C	20.6 0.456	C	20.6 0.456	+ 0.000 D/V

Kittelson & Associates, Inc. - Project # 6743
Milton-Freewater STA and TSP Update, Milton-Freewater, OR
2025 Total Traffic Conditions, Weekday PM Peak Hour

Level Of Service Computation Report
2000 HCM Unsignalized Method (Base Volume Alternative)

Intersection #1 OR 117 14th Ave

Average Delay (sec/veh): 5.1 Worst Case Level Of Service: D [27.5]

Table with 4 columns: North Bound, South Bound, East Bound, West Bound. Rows include Approach, Movement, Control, Rights, and Lanes.

Volume Module: >> Count Date: 1 Dec 2004 <<. Table with 4 columns and 8 rows of traffic volume data.

Critical Gap Module: Table with 4 columns and 2 rows of critical gap and follow-up time data.

Capacity Module: Table with 4 columns and 4 rows of capacity and volume/capacity data.

Level Of Service Module: Table with 4 columns and 8 rows of queue, stopped delay, and LOS data.

Kittelson & Associates, Inc. - Project # 6743
Milton-Freewater STA and TSP Update, Milton-Freewater, OR
2025 Total Traffic Conditions, Weekday PM Peak Hour

Level Of Service Computation Report
2000 HCM Unsignalized Method (Base Volume Alternative)

Intersection #2 Main Street-OR117 12th Ave

Average Delay (sec/veh): 1.9 Worst Case Level Of Service: F [73.7]

Table with 4 columns: North Bound, South Bound, East Bound, West Bound. Rows include Approach, Movement, Control, Rights, and Lanes.

Volume Module: >> Count Date: 7 Dec 2004 <<. Table with 4 columns and 8 rows of traffic volume data.

Critical Gap Module: Table with 4 columns and 2 rows of critical gap and follow-up time data.

Capacity Module: Table with 4 columns and 4 rows of capacity and volume/capacity data.

Level Of Service Module: Table with 4 columns and 8 rows of queue, stopped delay, and LOS data.

Kittelson & Associates, Inc. - Project # 6743
Milton-Freewater STA and TSP Update, Milton-Freewater, OR
2025 Total Traffic Conditions, Weekday PM Peak Hour

Level Of Service Computation Report
2000 HCM Unsignalized Method (Base Volume Alternative)

Intersection #3 Main Street - OR 11/ 10th Ave

Average Delay (sec/veh): 2.4 Worst Case Level Of Service: F [88.3]

Table with columns: Approach: North Bound, South Bound, East Bound, West Bound; Movement: L-T-R; Control: Uncontrolled, Stop Sign; Rights: Include; Lanes: 0 1 0 1 0

Volume Module: >> Count Date: 18 Nov 2004 << Base Vol: 5 488 2 7 531 17 19 2 4 5 2 17 Growth Adj: 1.32 1.52 1.32 1.32 1.32 1.32 1.32 1.32 1.32 1.32 1.32 1.32 Initial Bse: 7 741 3 9 806 22 25 3 5 7 3 22 User Adj: 1.00 1.00 1.00 1.00 1.00 1.00 1.00 1.00 1.00 1.00 1.00 1.00 PHF Adj: 0.80 0.80 0.80 0.80 0.80 0.80 0.80 0.80 0.80 0.80 0.80 0.80 PHF Volume: 8 926 3 12 1008 28 31 3 7 8 3 28 Reduct Vol: 0 0 0 0 0 0 0 0 0 0 0 0 Final Vol.: 8 926 3 12 1008 28 31 3 7 8 3 28

Critical Gap Module: Critical Gp: 4.1 xxxx xxxxx 4.1 xxxx xxxxx 7.5 6.5 6.9 7.5 6.5 6.9 FollowUpTim: 2.2 xxxx xxxxx 2.2 xxxx xxxxx 3.5 4.0 3.3 3.5 4.0 3.3

Capacity Module: Cnflct Vol: 1036 xxxx xxxxx 929 xxxx xxxxx 1526 1990 518 1473 2003 465 Potent Cap.: 667 xxxx xxxxx 732 xxxx xxxxx 81 60 503 88 59 544 Move Cap.: 667 xxxx xxxxx 732 xxxx xxxxx 72 58 503 82 57 544 Volume/Cap: 0.01 xxxx xxxx 0.02 xxxx xxxx 0.44 0.06 0.01 0.10 0.06 0.05

Level Of Service Module: Queue: 0.0 xxxx xxxxx 0.0 xxxx xxxxx xxxxx xxxx xxxxx xxxxx xxxx xxxxx Stopped Del: 10.5 xxxx xxxxx 10.0 xxxx xxxxx xxxxx xxxx xxxxx xxxxx xxxx xxxxx LOS by Move: B * * A * * Movement: LT - LTR - RT LT - LTR - RT LT - LTR - RT LT - LTR - RT Shared Cap.: xxxx xxxx xxxxx xxxx xxxx xxxxx xxxx 81 xxxxx xxxx 188 xxxxx Shared Queue: 0.0 xxxx xxxxx 0.0 xxxx xxxxx xxxxx 2.2 xxxxx xxxxx 0.8 xxxxx Shrd StpDel: 10.5 xxxx xxxxx 10.0 xxxx xxxxx xxxxx 88.3 xxxxx xxxxx 29.1 xxxxx Shared LOS: B * * A * * F * * D * * ApproachDel: xxxxxx xxxxxx 88.3 29.1 ApproachLOS: * * F D

Kittelson & Associates, Inc. - Project # 6743
Milton-Freewater STA and TSP Update, Milton-Freewater, OR
2025 Total Traffic Conditions, Weekday PM Peak Hour

Level Of Service Computation Report
2000 HCM Unsignalized Method (Base Volume Alternative)

Intersection #4 Main Street - OR 11/ 9th Ave

Average Delay (sec/veh): 1.3 Worst Case Level Of Service: E [46.7]

Table with columns: Approach: North Bound, South Bound, East Bound, West Bound; Movement: L-T-R; Control: Uncontrolled, Stop Sign; Rights: Include; Lanes: 0 1 0 1 0

Volume Module: >> Count Date: 22 Nov 2004 << Base Vol: 1 522 2 31 542 14 9 1 5 8 1 11 Growth Adj: 1.32 1.52 1.32 1.32 1.52 1.32 1.32 1.32 1.32 1.32 1.32 1.32 Initial Bse: 1 792 3 41 823 18 12 1 7 11 1 15 User Adj: 1.00 1.00 1.00 1.00 1.00 1.00 1.00 1.00 1.00 1.00 1.00 1.00 PHF Adj: 0.89 0.89 0.89 0.89 0.89 0.89 0.89 0.89 0.89 0.89 0.89 0.89 PHF Volume: 1 890 3 46 924 21 13 1 7 12 1 16 Reduct Vol: 0 0 0 0 0 0 0 0 0 0 0 0 Final Vol.: 1 890 3 46 924 21 13 1 7 12 1 16

Critical Gap Module: Critical Gp: 4.1 xxxx xxxxx 4.1 xxxx xxxxx 7.5 6.5 6.9 7.5 6.5 6.9 FollowUpTim: 2.2 xxxx xxxxx 2.2 xxxx xxxxx 3.5 4.0 3.3 3.5 4.0 3.3

Capacity Module: Cnflct Vol: 945 xxxx xxxxx 893 xxxx xxxxx 1476 1923 473 1450 1932 447 Potent Cap.: 722 xxxx xxxxx 755 xxxx xxxxx 88 66 538 92 65 559 Move Cap.: 722 xxxx xxxxx 755 xxxx xxxxx 80 62 538 85 61 559 Volume/Cap: 0.00 xxxx xxxx 0.06 xxxx xxxx 0.17 0.02 0.01 0.14 0.02 0.03

Level Of Service Module: Queue: 0.0 xxxx xxxxx 0.2 xxxx xxxxx xxxxx xxxx xxxxx xxxxx xxxx xxxxx Stopped Del: 10.0 xxxx xxxxx 10.1 xxxx xxxxx xxxxx xxxx xxxxx xxxxx xxxx xxxxx LOS by Move: A * * B * * Movement: LT - LTR - RT LT - LTR - RT LT - LTR - RT LT - LTR - RT Shared Cap.: xxxx xxxx xxxxx xxxx xxxx xxxxx xxxx 108 xxxxx xxxx 153 xxxxx Shared Queue: 0.0 xxxx xxxxx 0.2 xxxx xxxxx xxxxx 0.7 xxxxx xxxxx 0.7 xxxxx Shrd StpDel: 10.0 xxxx xxxxx 10.1 xxxx xxxxx xxxxx 46.7 xxxxx xxxxx 34.1 xxxxx Shared LOS: A * * B * * E * * D * * ApproachDel: xxxxxx xxxxxx 46.7 34.1 ApproachLOS: * * E D

Kittelson & Associates, Inc. - Project # 6743
 Milton-Freewater STA and TSP Update, Milton-Freewater, OR
 2025 Total Traffic Conditions, Weekday PM Peak Hour

Level Of Service Computation Report
 2000 HCM Unsignalized Method (Base Volume Alternative)

 Intersection #5 Main Street-OR11/ Bth Ave

Average Delay (sec/veh): 4.3 Worst Case Level Of Service: F[162.9]

Approach:	North Bound			South Bound			East Bound			West Bound		
Movement:	L	T	R	L	T	R	L	T	R	L	T	R
Control:	Uncontrolled			Uncontrolled			Stop Sign			Stop Sign		
Rights:	Include			Include			Include			Include		
Lanes:	0	1	0	1	0	1	0	0	1	0	0	1
Volume Module: >> Count Date: 29 Nov 2004 <<												
Base Vol:	6	527	9	13	578	43	24	3	6	3	1	1
Growth Adj:	1.32	1.52	1.32	1.32	1.52	1.32	1.32	1.32	1.32	1.32	1.32	1.32
Initial Bse:	8	800	12	17	877	57	32	4	8	4	1	1
User Adj:	1.00	1.00	1.00	1.00	1.00	1.00	1.00	1.00	1.00	1.00	1.00	1.00
PHF Adj:	0.81	0.81	0.81	0.81	0.81	0.81	0.81	0.81	0.81	0.81	0.81	0.81
PHF Volume:	10	988	15	21	1083	70	39	5	10	5	2	2
Reduct Vol:	0	0	0	0	0	0	0	0	0	0	0	0
Final Vol.:	10	988	15	21	1083	70	39	5	10	5	2	2

Critical Gap Module:

Critical Gp:	4.1	xxxx	xxxxx	4.1	xxxx	xxxxx	7.5	6.5	6.9	7.5	6.5	6.9
FollowUpTim:	2.2	xxxx	xxxxx	2.2	xxxx	xxxxx	3.5	4.0	3.3	3.5	4.0	3.3

Capacity Module:

Cnflct Vol:	1153	xxxx	xxxxx	1002	xxxx	xxxxx	1675	2182	577	1601	2210	501
Potent Cap.:	602	xxxx	xxxxx	687	xxxx	xxxxx	62	45	460	71	44	515
Move Cap.:	602	xxxx	xxxxx	687	xxxx	xxxxx	58	43	460	61	41	515
Volume/Cap:	0.02	xxxx	xxxx	0.03	xxxx	xxxx	0.67	0.11	0.02	0.08	0.04	0.00

Level Of Service Module:

Queue:	0.0	xxxx	xxxxx	0.1	xxxx	xxxxx	xxxxx	xxxx	xxxxx	xxxxx	xxxx	xxxxx
Stopped Del:	11.1	xxxx	xxxxx	10.4	xxxx	xxxxx	xxxxx	xxxx	xxxxx	xxxxx	xxxx	xxxxx
LOS by Move:	B	*	*	B	*	*	*	*	*	*	*	*
Movement:	LT - LTR - RT	LT - LTR - RT	LT - LTR - RT	LT - LTR - RT	LT - LTR - RT	LT - LTR - RT	LT - LTR - RT	LT - LTR - RT	LT - LTR - RT	LT - LTR - RT	LT - LTR - RT	
Shared Cap.:	xxxx	xxxx	xxxxx	xxxx	xxxx	xxxxx	xxxx	67	xxxxx	xxxx	66	xxxxx
Shared Queue:	0.0	xxxx	xxxxx	0.1	xxxx	xxxxx	xxxxx	3.8	xxxxx	xxxxx	0.4	xxxxx
Shrd StpDel:	11.1	xxxx	xxxxx	10.4	xxxx	xxxxx	xxxxx	163	xxxxx	xxxxx	66.6	xxxxx
Shared LOS:	B	*	*	B	*	*	*	F	*	F	*	*
ApproachDel:	xxxxxx	xxxxxx		xxxxxx	xxxxxx		162.9		66.6			
ApproachLOS:	*	*		*	*		F		F			

Kittelson & Associates, Inc. - Project # 6743
 Milton-Freewater STA and TSP Update, Milton-Freewater, OR
 2025 Total Traffic Conditions, Weekday PM Peak Hour

Level Of Service Computation Report
 2000 HCM Unsignalized Method (Base Volume Alternative)

 Intersection #6 OR 11/7th Ave - Eastbound

Average Delay (sec/veh): 2.7 Worst Case Level Of Service: F[102.4]

Approach:	North Bound			South Bound			East Bound			West Bound		
Movement:	L	T	R	L	T	R	L	T	R	L	T	R
Control:	Uncontrolled			Uncontrolled			Stop Sign			Stop Sign		
Rights:	Include			Include			Include			Include		
Lanes:	0	1	0	1	0	1	0	0	1	0	0	1
Volume Module:												
Base Vol:	6	544	0	0	631	20	31	3	3	0	0	0
Growth Adj:	1.32	1.56	1.32	1.32	1.56	1.32	1.32	1.32	1.32	1.32	1.32	1.32
Initial Bse:	8	847	0	0	983	26	41	4	4	0	0	0
User Adj:	1.00	1.00	1.00	1.00	1.00	1.00	1.00	1.00	1.00	1.00	1.00	1.00
PHF Adj:	0.86	0.86	0.86	0.86	0.86	0.86	0.86	0.86	0.86	0.86	0.86	0.86
PHF Volume:	9	985	0	0	1143	31	48	5	5	0	0	0
Reduct Vol:	0	0	0	0	0	0	0	0	0	0	0	0
Final Vol.:	9	985	0	0	1143	31	48	5	5	0	0	0

Critical Gap Module:

Critical Gp:	4.1	xxxx	xxxxx	xxxxx	xxxx	xxxxx	6.8	6.5	6.9	xxxxx	xxxx	xxxxx
FollowUpTim:	2.2	xxxx	xxxxx	xxxxx	xxxx	xxxxx	3.5	4.0	3.3	xxxxx	xxxx	xxxxx

Capacity Module:

Cnflct Vol:	1174	xxxx	xxxxx	xxxx	xxxx	xxxxx	1669	2162	587	xxxx	xxxx	xxxxx
Potent Cap.:	591	xxxx	xxxxx	xxxx	xxxx	xxxxx	89	48	458	xxxx	xxxx	xxxxx
Move Cap.:	591	xxxx	xxxxx	xxxx	xxxx	xxxxx	88	47	458	xxxx	xxxx	xxxxx
Volume/Cap:	0.02	xxxx	xxxx	xxxx	xxxx	xxxx	0.54	0.10	0.01	xxxx	xxxx	xxxxx

Level Of Service Module:

Queue:	0.0	xxxx	xxxxx	xxxxx	xxxx	xxxxx	xxxxx	xxxx	xxxxx	xxxxx	xxxx	xxxxx
Stopped Del:	11.2	xxxx	xxxxx	xxxxx	xxxx	xxxxx	xxxxx	xxxx	xxxxx	xxxxx	xxxx	xxxxx
LOS by Move:	B	*	*	*	*	*	*	*	*	*	*	*
Movement:	LT - LTR - RT	LT - LTR - RT	LT - LTR - RT	LT - LTR - RT	LT - LTR - RT	LT - LTR - RT	LT - LTR - RT	LT - LTR - RT	LT - LTR - RT	LT - LTR - RT	LT - LTR - RT	
Shared Cap.:	xxxx	xxxx	xxxxx	xxxx	xxxx	xxxxx	xxxx	87	xxxxx	xxxx	0	xxxxx
Shared Queue:	0.0	xxxx	xxxxx	0.0	xxxx	xxxxx	xxxxx	3.1	xxxxx	xxxxx	xxxx	xxxxx
Shrd StpDel:	11.2	xxxx	xxxxx	9.0	xxxx	xxxxx	xxxxx	102	xxxxx	xxxxx	xxxx	xxxxx
Shared LOS:	B	*	*	A	*	*	F	*	*	*	*	*
ApproachDel:	xxxxxx	xxxxxx		xxxxxx	xxxxxx		102.4		xxxxxx			
ApproachLOS:	*	*		*	*		F		*			

Kittelson & Associates, Inc. - Project # 6743
Milton-Freewater STA and TSP Update, Milton-Freewater, OR
2025 Total Traffic Conditions, Weekday PM Peak Hour

Level Of Service Computation Report
2000 HCM Unsignalized Method (Base Volume Alternative)

Intersection #7 OR 11/7th Avenue - Westbound

Average Delay (sec/veh): 0.2 Worst Case Level Of Service: C [15.4]

Table with 4 columns: North Bound, South Bound, East Bound, West Bound. Rows include Movement, Control, Rights, and Lanes.

Volume Module table with 12 columns and 8 rows including Base Vol, Growth Adj, Initial Bse, User Adj, PHF Adj, PHF Volume, Reduct Vol, and Final Vol.

Critical Gap Module table with 4 columns and 2 rows including Critical Gp and FollowUpTim.

Capacity Module table with 4 columns and 4 rows including Conflict Vol, Potent Cap., Move Cap., and Volume/Cap.

Level Of Service Module table with 12 columns and 10 rows including Queue, Stopped Del, LOS by Move, Movement, Shared Cap., Shared Queue, Shrd StpDel, Shared LOS, ApproachDel, and ApproachLOS.

Kittelson & Associates, Inc. - Project # 6743
Milton-Freewater STA and TSP Update, Milton-Freewater, OR
2025 Total Traffic Conditions, Weekday PM Peak Hour

Level Of Service Computation Report
2000 HCM Unsignalized Method (Base Volume Alternative)

Intersection #8 OR 11/ 4th Avenue

Average Delay (sec/veh): 0.6 Worst Case Level Of Service: F [74.5]

Table with 4 columns: North Bound, South Bound, East Bound, West Bound. Rows include Movement, Control, Rights, and Lanes.

Volume Module table with 12 columns and 8 rows including Base Vol, Growth Adj, Initial Bse, User Adj, PHF Adj, PHF Volume, Reduct Vol, and Final Vol.

Critical Gap Module table with 4 columns and 2 rows including Critical Gp and FollowUpTim.

Capacity Module table with 4 columns and 4 rows including Conflict Vol, Potent Cap., Move Cap., and Volume/Cap.

Level Of Service Module table with 12 columns and 10 rows including Queue, Stopped Del, LOS by Move, Movement, Shared Cap., Shared Queue, Shrd StpDel, Shared LOS, ApproachDel, and ApproachLOS.

Kittelson & Associates, Inc. - Project # 6743
 Milton-Freewater STA and TSP Update, Milton-Freewater, OR
 2025 Total Traffic Conditions, Weekday PM Peak Hour

Level Of Service Computation Report
 2000 HCM Operations Method (Base Volume Alternative)

 Intersection #9 Main Street/OR11/ 2nd Ave

Cycle (sec): 100 Critical Vol./Cap. (X): 0.456
 Loss Time (sec): 12 (Y+R = 4 sec) Average Delay (sec/veh): 20.6
 Optimal Cycle: 38 Level Of Service: C

Approach:	North Bound			South Bound			East Bound			West Bound		
Movement:	L	T	R	L	T	R	L	T	R	L	T	R
Control:	Permitted			Permitted			Split Phase			Split Phase		
Rights:	Ignore			Include			Include			Include		
Min. Green:	0	0	0	0	0	0	0	0	0	0	0	0
Lanes:	0	1	1	0	0	1	0	0	1	1	0	1

Volume Module:	>>	Count	Date:	30 Nov 2004	<<													
Base Vol:	7	187	398	0	189	12	5	0	9	481	31	6						
Growth Adj:	1.32	1.61	1.61	1.32	1.61	1.32	1.32	1.32	1.32	1.61	1.32	1.32						
Initial Bse:	9	301	641	0	304	16	7	0	12	775	41	8						
User Adj:	1.00	1.00	0.00	1.00	1.00	1.00	1.00	1.00	1.00	1.00	1.00	1.00						
PHF Adj:	0.92	0.92	0.00	0.92	0.92	0.92	0.92	0.92	0.92	0.92	0.92	0.92						
PHF Volume:	10	327	0	0	331	17	7	0	13	842	44	9						
Reduct Vol:	0	0	0	0	0	0	0	0	0	0	0	0						
Reduced Vol:	10	327	0	0	331	17	7	0	13	842	44	9						
PCE Adj:	1.00	1.00	0.00	1.00	1.00	1.00	1.00	1.00	1.00	1.00	1.00	1.00						
MLF Adj:	1.00	1.00	0.00	1.00	1.00	1.00	1.00	1.00	1.00	1.00	1.00	1.00						
Final Vol.:	10	327	0	0	331	17	7	0	13	842	44	9						

Saturation Flow Module:												
Sat/Lane:	1800	1800	1800	1800	1800	1800	1800	1800	1800	1800	1800	1800
Adjustment:	0.88	0.88	1.00	1.00	0.92	0.92	0.88	1.00	0.88	0.93	0.93	0.93
Lanes:	0.06	1.94	1.00	0.00	1.90	0.10	0.36	0.00	0.64	1.89	0.09	0.02
Final Sat.:	94	3060	1800	0	3164	165	565	0	1017	3177	158	31

Capacity Analysis Module:												
Vol/Sat:	0.11	0.11	0.00	0.00	0.10	0.10	0.01	0.00	0.01	0.26	0.28	0.28
Crit Moves:	****						****			****		
Green/Cycle:	0.23	0.23	0.00	0.00	0.23	0.23	0.03	0.00	0.03	0.62	0.62	0.62
Volume/Cap:	0.46	0.46	0.00	0.00	0.45	0.45	0.46	0.00	0.46	0.43	0.46	0.46
Delay/Veh:	36.2	33.3	0.0	0.0	33.1	33.1	55.2	0.0	55.2	10.1	10.3	10.3
User DelAdj:	1.00	1.00	1.00	1.00	1.00	1.00	1.00	1.00	1.00	1.00	1.00	1.00
AdjDel/Veh:	36.2	33.3	0.0	0.0	33.1	33.1	55.2	0.0	55.2	10.1	10.3	10.3
HCM2kAvg:	5	5	0	0	5	5	1	0	1	7	8	8

Traffic 7.7.1115 (c) 2004 Dowling Assoc. Licensed to KITTELSON, PORTLAND

Appendix E

2004 Traffic Operations Analysis Worksheets – Three-Lane Option

Kittelton & Associates, Inc. - Project #6743
 Milton-Freewater STA and TSP Update - Milton-Freewater, OR
 2004 Three-Lane Traffic Condition, Weekday AM Peak Hour

Scenario Report

Scenario: AM-3Lane
 Command: AM-3Lane
 Volume: AM
 Geometry: 3-lane
 Impact Fee: Default Impact Fee
 Trip Generation: Default Trip Generation
 Trip Distribution: Default Trip Distribution
 Paths: Default Paths
 Routes: Default Routes
 Configuration: Default Configuration

Kittelton & Associates, Inc. - Project #6743
 Milton-Freewater STA and TSP Update - Milton-Freewater, OR
 2004 Three-Lane Traffic Condition, Weekday AM Peak Hour

Impact Analysis Report
Level Of Service

Intersection	Base		Future		Change in:
	Del/ LOS	V/ Veh C	Del/ LOS	V/ Veh C	
# 1 OR 11/ 14th Ave	C	20.9 0.000	C	20.9 0.000	+ 0.000 D/V
# 2 Main Street-OR11/ 12th Ave	E	38.4 0.000	E	38.4 0.000	+ 0.000 D/V
# 3 Main Street - OR 11/ 10th Ave	C	21.4 0.000	C	21.4 0.000	+ 0.000 D/V
# 4 Main Street - OR 11/ 9th Ave	D	25.2 0.000	D	25.2 0.000	+ 0.000 D/V
# 5 Main Street-OR11/ 8th Ave	D	29.3 0.000	D	29.3 0.000	+ 0.000 D/V
# 6 OR 11/7th Ave - Eastbound	E	36.3 0.000	E	36.3 0.000	+ 0.000 D/V
# 7 OR 11/7th Avenue - Westbound	C	20.0 0.000	C	20.0 0.000	+ 0.000 D/V
# 8 OR 11/ 4th Avenue	E	40.1 0.000	E	40.1 0.000	+ 0.000 D/V
# 9 Main Street/OR11/ 2nd Ave	C	21.7 0.417	C	21.7 0.417	+ 0.000 D/V

Kittelson & Associates, Inc. - Project #6743
Milton-Freewater STA and TSP Update - Milton-Freewater, OR
2004 Three-Lane Traffic Condition, Weekday AM Peak Hour

Level Of Service Computation Report
2000 HCM Unsignalized Method (Base Volume Alternative)

Intersection #1 OR 117 14th Ave

Average Delay (sec/veh): 4.6 Worst Case Level Of Service: C [20.9]

Table with columns: Approach, Movement, Control, Rights, Lanes, Volume Module, Base Vol, Growth Adj, Initial Bse, User Adj, PHF Adj, PHF Volume, Reduct Vol, Final Vol. Rows for North, South, East, West bounds.

Critical Gap Module: Critical Gp, FollowUpTim

Capacity Module: Cnflct Vol, Potent Cap, Move Cap, Volume/Cap

Level Of Service Module: Queue, Stopped Del, LOS by Move, Movement, Shared Cap, Shared Queue, Shrd StpDel, Shared LOS, ApproachDel, ApproachLOS

Kittelson & Associates, Inc. - Project #6743
Milton-Freewater STA and TSP Update - Milton-Freewater, OR
2004 Three-Lane Traffic Condition, Weekday AM Peak Hour

Level Of Service Computation Report
2000 HCM Unsignalized Method (Base Volume Alternative)

Intersection #2 Main Street-OR11/ 12th Ave

Average Delay (sec/veh): 2.1 Worst Case Level Of Service: E [38.4]

Table with columns: Approach, Movement, Control, Rights, Lanes, Volume Module, Base Vol, Growth Adj, Initial Bse, User Adj, PHF Adj, PHF Volume, Reduct Vol, Final Vol. Rows for North, South, East, West bounds.

Critical Gap Module: Critical Gp, FollowUpTim

Capacity Module: Cnflct Vol, Potent Cap, Move Cap, Volume/Cap

Level Of Service Module: Queue, Stopped Del, LOS by Move, Movement, Shared Cap, Shared Queue, Shrd StpDel, Shared LOS, ApproachDel, ApproachLOS

Kittelson & Associates, Inc. - Project #6743
Milton-Freewater STA and TSP Update - Milton-Freewater, OR
2004 Three-Lane Traffic Condition, Weekday AM Peak Hour

Level Of Service Computation Report
2000 HCM Unsignalized Method (Base Volume Alternative)

Intersection #3 Main Street - OR 11/ 10th Ave

Average Delay (sec/veh): 0.5 Worst Case Level Of Service: C [21.4]

Table with 4 columns: Approach: North Bound, South Bound, East Bound, West Bound. Rows include Movement, Control, Rights, and Lanes.

Table with 4 columns: Volume Module, Count, Date, and another Count. Rows include Base Vol, Growth Adj, Initial Bse, User Adj, PHF Adj, PHF Volume, Reduct Vol, and Final Vol.

Table with 4 columns: Critical Gap, FollowUpTim, and two sets of values. Rows include Critical Gap Module and FollowUpTim.

Table with 4 columns: Capacity Module, Conflict Vol, Potent Cap., Move Cap., and Volume/Cap. Rows include Conflict Vol, Potent Cap., Move Cap., and Volume/Cap.

Table with 4 columns: Level Of Service Module, Queue, Stopped Del, LOS by Move, Movement, Shared Cap., Shared Queue, Shrd StpDel, Shared LOS, ApproachDel, and ApproachLOS.

Kittelson & Associates, Inc. - Project #6743
Milton-Freewater STA and TSP Update - Milton-Freewater, OR
2004 Three-Lane Traffic Condition, Weekday AM Peak Hour

Level Of Service Computation Report
2000 HCM Unsignalized Method (Base Volume Alternative)

Intersection #4 Main Street - OR 11/ 9th Ave

Average Delay (sec/veh): 0.8 Worst Case Level Of Service: D [25.2]

Table with 4 columns: Approach: North Bound, South Bound, East Bound, West Bound. Rows include Movement, Control, Rights, and Lanes.

Table with 4 columns: Volume Module, Count, Date, and another Count. Rows include Base Vol, Growth Adj, Initial Bse, User Adj, PHF Adj, PHF Volume, Reduct Vol, and Final Vol.

Table with 4 columns: Critical Gap, FollowUpTim, and two sets of values. Rows include Critical Gap Module and FollowUpTim.

Table with 4 columns: Capacity Module, Conflict Vol, Potent Cap., Move Cap., and Volume/Cap. Rows include Conflict Vol, Potent Cap., Move Cap., and Volume/Cap.

Table with 4 columns: Level Of Service Module, Queue, Stopped Del, LOS by Move, Movement, Shared Cap., Shared Queue, Shrd StpDel, Shared LOS, ApproachDel, and ApproachLOS.

Kittelson & Associates, Inc. - Project #6743
Milton-Freewater STA and TSP Update - Milton-Freewater, OR
2004 Three-Lane Traffic Condition, Weekday AM Peak Hour

Level Of Service Computation Report
2000 HCM Unsignalized Method (Base Volume Alternative)

Intersection #5 Main Street-DR11/ Bth Ave

Average Delay (sec/veh): 1.3 Worst Case Level Of Service: D [29.3]

Table with columns: Approach: North Bound, South Bound, East Bound, West Bound; Movement: L-T-R; Control: Uncontrolled, Stop Sign; Rights: Include, Include, Include, Include; Lanes: 1 0 0 1 0, 1 0 0 1 0, 0 0 1! 0 0, 0 0 1! 0 0

Volume Module: >> Count Date: 29 Nov 2004 <<
Base Vol: 8 522 2 3 392 15 25 1 11 2 1 12
Growth Adj: 1.00 1.15 1.00 1.00 1.15 1.00 1.00 1.00 1.00 1.00 1.00 1.00
Initial Bse: 8 600 2 3 451 15 25 1 11 2 1 12
User Adj: 1.00 1.00 1.00 1.00 1.00 1.00 1.00 1.00 1.00 1.00 1.00 1.00
PHF Adj: 0.88 0.88 0.88 0.88 0.88 0.88 0.88 0.88 0.88 0.88 0.88 0.88
PHF Volume: 9 682 2 3 512 17 28 1 13 2 1 14
Reduct Vol: 0 0 0 0 0 0 0 0 0 0 0 0
Final Vol.: 9 682 2 3 512 17 28 1 13 2 1 14

Critical Gap Module:
Critical Gp: 4.1 xxxx xxxxx 4.1 xxxx xxxxx 7.1 6.5 6.2 7.1 6.5 6.2
FollowUpTim: 2.2 xxxx xxxxx 2.2 xxxx xxxxx 3.5 4.0 3.3 3.5 4.0 3.3

Capacity Module:
Conflict Vol: 529 xxxx xxxxx 684 xxxx xxxxx 1236 1230 521 1236 1238 683
Potent Cap.: 1038 xxxx xxxxx 909 xxxx xxxxx 154 179 560 154 177 453
Move Cap.: 1038 xxxx xxxxx 909 xxxx xxxxx 147 177 560 149 175 453
Volume/Cap: 0.01 xxxx xxxxx 0.00 xxxx xxxxx 0.19 0.01 0.02 0.02 0.01 0.03

Level Of Service Module:
Queue: 0.0 xxxx xxxxx 0.0 xxxx xxxxx xxxxx xxxxx xxxxx xxxxx xxxxx xxxxx
Stopped Del: 8.5 xxxx xxxxx 9.0 xxxx xxxxx xxxxx xxxxx xxxxx xxxxx xxxxx xxxxx
LOS by Move: A * * A * * * * * * * * * * * * * * * * * *
Movement: LT - LTR - RT LT - LTR - RT LT - LTR - RT LT - LTR - RT
Shared Cap.: xxxx xxxx xxxxx xxxx xxxx xxxxx xxxxx 190 xxxxx xxxxx 328 xxxxx
SharedQueue:xxxxx xxxx xxxxx xxxxx xxxx xxxxx xxxxx 0.8 xxxxx xxxxx 0.2 xxxxx
Shrd StpDel:xxxxx xxxx xxxxx xxxxx xxxx xxxxx xxxxx 29.3 xxxxx xxxxx 16.6 xxxxx
Shared LOS: *
ApproachDel: xxxxxx xxxxxx 29.3 16.6
ApproachLOS: *

Kittelson & Associates, Inc. - Project #6743
Milton-Freewater STA and TSP Update - Milton-Freewater, OR
2004 Three-Lane Traffic Condition, Weekday AM Peak Hour

Level Of Service Computation Report
2000 HCM Unsignalized Method (Base Volume Alternative)

Intersection #6 DR 11/7th Ave Eastbound

Average Delay (sec/veh): 0.3 Worst Case Level Of Service: E [36.3]

Table with columns: Approach: North Bound, South Bound, East Bound, West Bound; Movement: L-T-R; Control: Uncontrolled, Stop Sign; Rights: Include, Include, Include, Include; Lanes: 1 0 0 1 0, 1 0 0 1 0, 0 0 1! 0 0, 0 0 1! 0 0

Volume Module:
Base Vol: 2 556 0 0 408 13 7 1 2 0 0 0
Growth Adj: 1.00 1.18 1.00 1.00 1.18 1.00 1.00 1.00 1.00 1.00 1.00 1.00
Initial Bse: 2 656 0 0 481 13 7 1 2 0 0 0
User Adj: 1.00 1.00 1.00 1.00 1.00 1.00 1.00 1.00 1.00 1.00 1.00 1.00
PHF Adj: 0.70 0.70 0.70 0.70 0.70 0.70 0.70 0.70 0.70 0.70 0.70 0.70
PHF Volume: 3 937 0 0 688 19 10 1 3 0 0 0
Reduct Vol: 0 0 0 0 0 0 0 0 0 0 0 0
Final Vol.: 3 937 0 0 688 19 10 1 3 0 0 0

Critical Gap Module:
Critical Gp: 4.1 xxxx xxxxx xxxxx xxxx xxxxx 6.4 6.5 6.2 xxxxx xxxxx xxxxx
FollowUpTim: 2.2 xxxx xxxxx xxxxx xxxx xxxxx 3.5 4.0 3.3 xxxxx xxxx xxxxx

Capacity Module:
Conflict Vol: 706 xxxx xxxxx xxxxx xxxx xxxxx 1640 1640 697 xxxx xxxx xxxxx
Potent Cap.: 892 xxxx xxxxx xxxx xxxx xxxxx 111 101 444 xxxx xxxx xxxxx
Move Cap.: 892 xxxx xxxxx xxxx xxxx xxxxx 111 101 444 xxxx xxxx xxxxx
Volume/Cap: 0.00 xxxx xxxxx xxxxx xxxx xxxxx 0.09 0.01 0.01 xxxx xxxx xxxxx

Level Of Service Module:
Queue: 0.0 xxxx xxxxx xxxxx xxxx xxxxx xxxxx xxxx xxxxx xxxxx xxxx xxxxx
Stopped Del: 9.0 xxxx xxxxx xxxxx xxxx xxxxx xxxxx xxxx xxxxx xxxxx xxxx xxxxx
LOS by Move: A * * * * * * * * * * * * * * * * * *
Movement: LT - LTR - RT LT - LTR - RT LT - LTR - RT LT - LTR - RT
Shared Cap.: xxxx xxxx xxxxx xxxx xxxx xxxxx xxxxx 129 xxxxx xxxx 0 xxxxx
SharedQueue:xxxxx xxxx xxxxx xxxxx xxxx xxxxx xxxxx 0.4 xxxxx xxxxx xxxx xxxxx
Shrd StpDel:xxxxx xxxx xxxxx xxxxx xxxx xxxxx xxxxx 36.3 xxxxx xxxxx xxxx xxxxx
Shared LOS: *
ApproachDel: xxxxxx xxxxxx 36.3 xxxxxx
ApproachLOS: *

Kittelson & Associates, Inc. - Project #6743
Milton-Freewater STA and TSP Update - Milton-Freewater, OR
2004 Three-Lane Traffic Condition, Weekday AM Peak Hour

Level Of Service Computation Report
2000 HCM Unsignalized Method (Base Volume Alternative)

Intersection #7 OR 11/7th Avenue - Westbound

Average Delay (sec/veh): 0.4 Worst Case Level Of Service: C [20.0]

Table with 4 columns: North Bound, South Bound, East Bound, West Bound. Rows include Approach, Movement, Control, Rights, Lanes.

Volume Module table with 12 columns and 10 rows including Base Vol, Growth Adj, Initial Bse, User Adj, PHF Adj, PHF Volume, Reduct Vol, Final Vol.

Critical Gap Module table with 6 columns and 2 rows including Critical Gp, FollowUpTim.

Capacity Module table with 12 columns and 4 rows including Conflict Vol, Potent Cap, Move Cap, Volume/Cap.

Level Of Service Module table with 12 columns and 10 rows including Queue, Stopped Del, LOS by Move, Movement, Shared Cap, Shared Queue, Shrd StpDel, Shared LOS, ApproachDel, ApproachLOS.

Kittelson & Associates, Inc. - Project #6743
Milton-Freewater STA and TSP Update - Milton-Freewater, OR
2004 Three-Lane Traffic Condition, Weekday AM Peak Hour

Level Of Service Computation Report
2000 HCM Unsignalized Method (Base Volume Alternative)

Intersection #8 OR 11/ 4th Avenue

Average Delay (sec/veh): 0.5 Worst Case Level Of Service: E [40.1]

Table with 4 columns: North Bound, South Bound, East Bound, West Bound. Rows include Approach, Movement, Control, Rights, Lanes.

Volume Module table with 12 columns and 10 rows including Base Vol, Growth Adj, Initial Bse, User Adj, PHF Adj, PHF Volume, Reduct Vol, Final Vol.

Critical Gap Module table with 6 columns and 2 rows including Critical Gp, FollowUpTim.

Capacity Module table with 12 columns and 4 rows including Conflict Vol, Potent Cap, Move Cap, Volume/Cap.

Level Of Service Module table with 12 columns and 10 rows including Queue, Stopped Del, LOS by Move, Movement, Shared Cap, Shared Queue, Shrd StpDel, Shared LOS, ApproachDel, ApproachLOS.

Kittelson & Associates, Inc. - Project #6743
Milton-Freewater STA and TSP Update - Milton-Freewater, OR
2004 Three-Lane Traffic Condition, Weekday AM Peak Hour

Level Of Service Computation Report
2000 HCM Operations Method (Base Volume Alternative)

Intersection #9 Main Street/OR11/ 2nd Ave

Cycle (sec): 100 Critical Vol./Cap. (X): 0.417
Loss Time (sec): 12 (Y+R = 4 sec) Average Delay (sec/veh): 21.7
Optimal Cycle: 36 Level Of Service: C

Approach:	North Bound			South Bound			East Bound			West Bound		
Movement:	L	T	R	L	T	R	L	T	R	L	T	R
Control:	Permitted			Permitted			Split Phase			Split Phase		
Rights:	Ignore			Include			Include			Include		
Min. Green:	0	0	0	0	0	0	0	0	0	0	0	0
Lanes:	0	1	0	0	1	0	0	0	1	0	0	1

Volume Module: >> Count Date: 30 Nov 2004 <<

Base Vol:	14	170	407	0	159	1	7	0	11	262	19	1
Growth Adj:	1.00	1.22	1.22	1.00	1.22	1.00	1.00	1.00	1.00	1.22	1.00	1.00
Initial Bse:	14	207	497	0	194	1	7	0	11	320	19	1
User Adj:	1.00	1.00	0.00	1.00	1.00	1.00	1.00	1.00	1.00	1.00	1.00	1.00
PHF Adj:	0.90	0.90	0.00	0.90	0.90	0.90	0.90	0.90	0.90	0.90	0.90	0.90
PHF Volume:	16	230	0	0	216	1	8	0	12	355	21	1
Reduced Vol:	0	0	0	0	0	0	0	0	0	0	0	0
Reduced Vol:	16	230	0	0	216	1	8	0	12	355	21	1
PCE Adj:	1.00	1.00	0.00	1.00	1.00	1.00	1.00	1.00	1.00	1.00	1.00	1.00
MLF Adj:	1.00	1.00	0.00	1.00	1.00	1.00	1.00	1.00	1.00	1.00	1.00	1.00
Final Vol.:	16	230	0	0	216	1	8	0	12	355	21	1

Saturation Flow Module:

Sat/Lane:	1800	1800	1800	1800	1800	1800	1800	1800	1800	1800	1800	1800
Adjustment:	0.96	0.96	1.00	1.00	0.98	0.98	0.88	1.00	0.88	0.93	0.97	0.97
Lanes:	0.06	0.94	1.00	0.00	0.99	0.01	0.39	0.00	0.61	1.00	0.95	0.05
Final Sat.:	109	1618	1800	0	1753	9	618	0	971	1676	1664	88

Capacity Analysis Module:

Vol/Sat:	0.14	0.14	0.00	0.00	0.12	0.12	0.01	0.00	0.01	0.21	0.01	0.01
Crit Moves:	****			****			****			****		
Green/Cycle:	0.34	0.34	0.00	0.00	0.34	0.34	0.03	0.00	0.03	0.51	0.51	0.51
Volume/Cap:	0.42	0.42	0.00	0.00	0.36	0.36	0.42	0.00	0.42	0.42	0.02	0.02
Delay/Veh:	25.8	25.8	0.0	0.0	25.1	25.1	53.4	0.0	53.4	15.7	12.3	12.3
User DelAdj:	1.00	1.00	1.00	1.00	1.00	1.00	1.00	1.00	1.00	1.00	1.00	1.00
AdjDel/Veh:	25.8	25.8	0.0	0.0	25.1	25.1	53.4	0.0	53.4	15.7	12.3	12.3
HCM2kAvg:	6	6	0	0	5	5	1	0	1	7	0	0

Kittelson & Associates, Inc. Project # 6743
 Milton-Freewater STP and TSP Update Plan, Milton-Freewater, OR
 2004 Three-Lane Traffic Condition, Weekday PM Peak Hour

Scenario Report

Scenario: PM-3Lane
 Command: PM-3Lane
 Volume: PM
 Geometry: 3-lane
 Impact Fee: Default Impact Fee
 Trip Generation: Default Trip Generation
 Trip Distribution: Default Trip Distribution
 Paths: Default Paths
 Routes: Default Routes
 Configuration: Default Configuration

Kittelson & Associates, Inc. Project # 6743
 Milton-Freewater STP and TSP Update Plan, Milton-Freewater, OR
 2004 Three-Lane Traffic Condition, Weekday PM Peak Hour

Impact Analysis Report
Level Of Service

Intersection	Base		Future		Change in
	LOS	Veh C	LOS	Veh C	
# 1 OR 11/ 14th Ave	C	19.9 0.000	C	19.9 0.000	+ 0.000 D/V
# 2 Main Street-OR11/ 12th Ave	E	44.8 0.000	E	44.8 0.000	+ 0.000 D/V
# 3 Main Street - OR 11/ 10th Ave	F	52.4 0.000	F	52.4 0.000	+ 0.000 D/V
# 4 Main Street - OR 11/ 9th Ave	D	34.6 0.000	D	34.6 0.000	+ 0.000 D/V
# 5 Main Street-OR11/ 8th Ave	F	72.1 0.000	F	72.1 0.000	+ 0.000 D/V
# 6 OR 11/7th Ave - Eastbound	F	53.0 0.000	F	53.0 0.000	+ 0.000 D/V
# 7 OR 11/7th Avenue - Westbound	C	16.6 0.000	C	16.6 0.000	+ 0.000 D/V
# 8 OR 11/ 4th Avenue	F	51.1 0.000	F	51.1 0.000	+ 0.000 D/V
# 9 Main Street/OR11/ 2nd Ave	C	23.5 0.615	C	23.5 0.615	+ 0.000 D/V

Kittelson & Associates, Inc. Project # 6743
Milton-Freewater STP and TSP Update Plan, Milton-Freewater, OR
2004 Three-Lane Traffic Condition, Weekday PM Peak Hour

Level Of Service Computation Report
2000 HCM Unsignalized Method (Base Volume Alternative)

Intersection #1 OR 11/ 14th Ave

Average Delay (sec/veh): 3.9 Worst Case Level Of Service: C [19.9]

Table with 4 columns: North Bound, South Bound, East Bound, West Bound. Rows include Movement, Control, Rights, Lanes.

Volume Module: >> Count Date: 1 Dec 2004 <<. Rows include Base Vol, Growth Adj, Initial Bse, User Adj, PHF Adj, PHF Volume, Reduct Vol, Final Vol.

Critical Gap Module: Critical Gp, FollowUpTim. Values: 4.1, 2.2, 6.4, 3.5.

Capacity Module: Cnflct Vol, Potent Cap., Move Cap., Volume/Cap. Values: 562, 1009, 110, 0.20.

Level Of Service Module: Queue, Stopped Del, LOS by Move, Movement, Shared Cap., Shared Queue, Shrd StpDel, Shared LOS, ApproachDel, ApproachLOS.

Kittelson & Associates, Inc. Project # 6743
Milton-Freewater STP and TSP Update Plan, Milton-Freewater, OR
2004 Three-Lane Traffic Condition, Weekday PM Peak Hour

Level Of Service Computation Report
2000 HCM Unsignalized Method (Base Volume Alternative)

Intersection #2 Main Street-OR11/ 12th Ave

Average Delay (sec/veh): 1.3 Worst Case Level Of Service: E [44.8]

Table with 4 columns: North Bound, South Bound, East Bound, West Bound. Rows include Movement, Control, Rights, Lanes.

Volume Module: >> Count Date: 7 Dec 2004 <<. Rows include Base Vol, Growth Adj, Initial Bse, User Adj, PHF Adj, PHF Volume, Reduct Vol, Final Vol.

Critical Gap Module: Critical Gp, FollowUpTim. Values: 4.1, 2.2, 7.1, 3.5, 6.5, 4.0, 6.2, 3.3.

Capacity Module: Cnflct Vol, Potent Cap., Move Cap., Volume/Cap. Values: 641, 944, 110, 0.05.

Level Of Service Module: Queue, Stopped Del, LOS by Move, Movement, Shared Cap., Shared Queue, Shrd StpDel, Shared LOS, ApproachDel, ApproachLOS.

Kittelson & Associates, Inc. Project # 6743
Milton-Freewater STP and TSP Update Plan, Milton-Freewater, OR
2004 Three-Lane Traffic Condition, Weekday PM Peak Hour

Level Of Service Computation Report
2000 HCM Unsignalized Method (Base Volume Alternative)

Intersection #3 Main Street - OR 11/ 10th Ave

Average Delay (sec/veh): 1.6 Worst Case Level Of Service: F [52.4]

Table with 4 columns: North Bound, South Bound, East Bound, West Bound. Rows include Control Rights, Lanes, and Volume Module.

Table with 4 columns: North Bound, South Bound, East Bound, West Bound. Rows include Base Vol, Growth Adj, Initial Bse, User Adj, PHF Adj, PHF Volume, Reduct Vol, Final Vol.

Table with 4 columns: North Bound, South Bound, East Bound, West Bound. Rows include Critical Gap, FollowUpTim.

Table with 4 columns: North Bound, South Bound, East Bound, West Bound. Rows include Capacity Module, Conflict Vol, Potent Cap, Move Cap, Volume/Cap.

Table with 4 columns: North Bound, South Bound, East Bound, West Bound. Rows include Level Of Service Module, Queue, Stopped Del, LOS by Move, Movement, Shared Cap, Shared Queue, Shrd StpDel, Shared LOS, ApproachDel, ApproachLOS.

Kittelson & Associates, Inc. Project # 6743
Milton-Freewater STP and TSP Update Plan, Milton-Freewater, OR
2004 Three-Lane Traffic Condition, Weekday PM Peak Hour

Level Of Service Computation Report
2000 HCM Unsignalized Method (Base Volume Alternative)

Intersection #4 Main Street - OR 11/ 9th Ave

Average Delay (sec/veh): 1.0 Worst Case Level Of Service: D [34.6]

Table with 4 columns: North Bound, South Bound, East Bound, West Bound. Rows include Control Rights, Lanes, and Volume Module.

Table with 4 columns: North Bound, South Bound, East Bound, West Bound. Rows include Base Vol, Growth Adj, Initial Bse, User Adj, PHF Adj, PHF Volume, Reduct Vol, Final Vol.

Table with 4 columns: North Bound, South Bound, East Bound, West Bound. Rows include Critical Gap, FollowUpTim.

Table with 4 columns: North Bound, South Bound, East Bound, West Bound. Rows include Capacity Module, Conflict Vol, Potent Cap, Move Cap, Volume/Cap.

Table with 4 columns: North Bound, South Bound, East Bound, West Bound. Rows include Level Of Service Module, Queue, Stopped Del, LOS by Move, Movement, Shared Cap, Shared Queue, Shrd StpDel, Shared LOS, ApproachDel, ApproachLOS.

Kittelson & Associates, Inc. Project # 6743
Milton-Freewater STP and TSP Update Plan, Milton-Freewater, OR
2004 Three-Lane Traffic Condition, Weekday PM Peak Hour

Level Of Service Computation Report
2000 HCM Unsignalized Method (Base Volume Alternative)

Intersection #5 Main Street-OR11/ 8th Ave

Average Delay (sec/veh): 2.0 Worst Case Level Of Service: FI 72.11

Table with 4 columns: North Bound, South Bound, East Bound, West Bound. Rows include Approach, Movement, Control, Rights, and Lanes.

Table with 4 columns: North Bound, South Bound, East Bound, West Bound. Rows include Volume Module, Base Vol, Growth Adj, Initial Bse, User Adj, PHF Adj, PHF Volume, Reduct Vol, and Final Vol.

Table with 4 columns: North Bound, South Bound, East Bound, West Bound. Rows include Critical Gap Module and FollowUpTim.

Table with 4 columns: North Bound, South Bound, East Bound, West Bound. Rows include Capacity Module, Cnflct Vol, Potent Cap., Move Cap., and Volume/Cap.

Table with 4 columns: North Bound, South Bound, East Bound, West Bound. Rows include Level Of Service Module, Queue, Stopped Del, LOS by Move, Movement, Shared Cap., Shrd StpDel, and Shared LOS.

Kittelson & Associates, Inc. Project # 6743
Milton-Freewater STP and TSP Update Plan, Milton-Freewater, OR
2004 Three-Lane Traffic Condition, Weekday PM Peak Hour

Level Of Service Computation Report
2000 HCM Unsignalized Method (Base Volume Alternative)

Intersection #6 OR 11/7th Ave - Eastbound

Average Delay (sec/veh): 1.4 Worst Case Level Of Service: FI 53.01

Table with 4 columns: North Bound, South Bound, East Bound, West Bound. Rows include Approach, Movement, Control, Rights, and Lanes.

Table with 4 columns: North Bound, South Bound, East Bound, West Bound. Rows include Volume Module, Base Vol, Growth Adj, Initial Bse, User Adj, PHF Adj, PHF Volume, Reduct Vol, and Final Vol.

Table with 4 columns: North Bound, South Bound, East Bound, West Bound. Rows include Critical Gap Module and FollowUpTim.

Table with 4 columns: North Bound, South Bound, East Bound, West Bound. Rows include Capacity Module, Cnflct Vol, Potent Cap., Move Cap., and Volume/Cap.

Table with 4 columns: North Bound, South Bound, East Bound, West Bound. Rows include Level Of Service Module, Queue, Stopped Del, LOS by Move, Movement, Shared Cap., Shrd StpDel, and Shared LOS.

Kittelson & Associates, Inc. Project # 6743
Milton-Freewater STP and TSP Update Plan, Milton-Freewater, OR
2004 Three-Lane Traffic Condition, Weekday PM Peak Hour

Level Of Service Computation Report
2000 HCM Unsignalized Method (Base Volume Alternative)

Intersection #7 OR 11/7th Avenue - Westbound

Average Delay (sec/veh): 0.2 Worst Case Level Of Service: C [16.6]

Table with 4 columns: North Bound, South Bound, East Bound, West Bound. Rows include Approach, Movement, Control, Rights, Lanes.

Volume Module:

Table with 4 columns: North Bound, South Bound, East Bound, West Bound. Rows include Base Vol, Growth Adj, Initial Bse, User Adj, PHF Adj, PHF Volume, Reduct Vol, Final Vol.

Critical Gap Module:

Table with 4 columns: North Bound, South Bound, East Bound, West Bound. Rows include Critical Gap, FollowUpTime.

Capacity Module:

Table with 4 columns: North Bound, South Bound, East Bound, West Bound. Rows include Conflict Vol, Potent Cap, Move Cap, Volume/Cap.

Level Of Service Module:

Table with 4 columns: North Bound, South Bound, East Bound, West Bound. Rows include Queue, Stopped Del, LOS by Move, Movement, Shared Cap, Shared Queue, Shrd StpDel, Shared LOS, ApproachDel, ApproachLOS.

Kittelson & Associates, Inc. Project # 6743
Milton-Freewater STP and TSP Update Plan, Milton-Freewater, OR
2004 Three-Lane Traffic Condition, Weekday PM Peak Hour

Level Of Service Computation Report
2000 HCM Unsignalized Method (Base Volume Alternative)

Intersection #8 OR 11/ 4th Avenue

Average Delay (sec/veh): 0.5 Worst Case Level Of Service: F [51.1]

Table with 4 columns: North Bound, South Bound, East Bound, West Bound. Rows include Approach, Movement, Control, Rights, Lanes.

Volume Module:

Table with 4 columns: North Bound, South Bound, East Bound, West Bound. Rows include Base Vol, Growth Adj, Initial Bse, User Adj, PHF Adj, PHF Volume, Reduct Vol, Final Vol.

Critical Gap Module:

Table with 4 columns: North Bound, South Bound, East Bound, West Bound. Rows include Critical Gap, FollowUpTime.

Capacity Module:

Table with 4 columns: North Bound, South Bound, East Bound, West Bound. Rows include Conflict Vol, Potent Cap, Move Cap, Volume/Cap.

Level Of Service Module:

Table with 4 columns: North Bound, South Bound, East Bound, West Bound. Rows include Queue, Stopped Del, LOS by Move, Movement, Shared Cap, Shared Queue, Shrd StpDel, Shared LOS, ApproachDel, ApproachLOS.

Kittelston & Associates, Inc. Project # 6743
Milton-Freewater STP and TSP Update Plan, Milton-Freewater, OR
2004 Three-Lane Traffic Condition, Weekday PM Peak Hour

Level Of Service Computation Report
2000 HCM Operations Method (Base Volume Alternative)

Intersection #9 Main Street/OR11/ 2nd Ave

Cycle (sec): 100 Critical Vol./Cap. (X): 0.615
Loss Time (sec): 12 (Y+R = 4 sec) Average Delay (sec/veh): 23.5
Optimal Cycle: 50 Level Of Service: C

Approach:	North Bound			South Bound			East Bound			West Bound		
Movement:	L	T	R	L	T	R	L	T	R	L	T	R
Control:	Permitted			Permitted			Split Phase			Split Phase		
Rights:	Ignore			Include			Include			Include		
Min. Green:	0	0	0	0	0	0	0	0	0	0	0	0
Lanes:	0	1	0	0	1	0	0	0	1	0	0	1

Volume Module: >> Count Date: 30 Nov 2004 <<

Base Vol:	7	187	398	0	189	12	5	0	9	481	31	6
Growth Adj:	1.00	1.22	1.22	1.00	1.22	1.00	1.00	1.00	1.00	1.22	1.00	1.00
Initial Bse:	7	228	486	0	231	12	5	0	9	587	31	6
User Adj:	1.00	1.00	0.00	1.00	1.00	1.00	1.00	1.00	1.00	1.00	1.00	1.00
PHF Adj:	0.92	0.92	0.00	0.92	0.92	0.92	0.92	0.92	0.92	0.92	0.92	0.92
PHF Volume:	8	248	0	0	251	13	5	0	10	638	34	7
Reduct Vol:	0	0	0	0	0	0	0	0	0	0	0	0
Reduced Vol:	8	248	0	0	251	13	5	0	10	638	34	7
PCE Adj:	1.00	1.00	0.00	1.00	1.00	1.00	1.00	1.00	1.00	1.00	1.00	1.00
MLF Adj:	1.00	1.00	0.00	1.00	1.00	1.00	1.00	1.00	1.00	1.00	1.00	1.00
Final Vol.:	8	248	0	0	251	13	5	0	10	638	34	7

Saturation Flow Module:

Sat/Lane:	1800	1800	1800	1800	1800	1800	1800	1800	1800	1800	1800	1800
Adjustment:	0.97	0.97	1.00	1.00	0.97	0.97	0.88	1.00	0.88	0.93	0.96	0.96
Lanes:	0.03	0.97	1.00	0.00	0.95	0.05	0.36	0.00	0.64	1.00	0.84	0.16
Final Sat.:	52	1694	1800	0	1665	87	565	0	1017	1676	1442	279

Capacity Analysis Module:

Vol/Sat:	0.15	0.15	0.00	0.00	0.15	0.15	0.01	0.00	0.01	0.38	0.02	0.02
Crit Moves:				****			****			****		
Green/Cycle:	0.24	0.24	0.00	0.00	0.24	0.24	0.02	0.00	0.02	0.62	0.62	0.62
Volume/Cap:	0.60	0.60	0.00	0.00	0.61	0.61	0.61	0.00	0.61	0.61	0.04	0.04
Delay/Veh:	35.7	35.7	0.0	0.0	36.2	36.2	87.2	0.0	87.2	12.8	7.4	7.4
User DelAdj:	1.00	1.00	1.00	1.00	1.00	1.00	1.00	1.00	1.00	1.00	1.00	1.00
AdjDel/Veh:	35.7	35.7	0.0	0.0	36.2	36.2	87.2	0.0	87.2	12.8	7.4	7.4
HCM2kAvg:	8	8	0	0	8	8	1	0	1	13	0	0

Appendix F

**2025 Traffic Operations
Analysis Worksheets –
Three-Lane Option**

Kittelson & Associates, Inc. Project #6743
 Milton-Freewater STP and TSP Update - Milton-Freewater, OR
 2025 Three-Lane Alternative, Weekday PM Peak Hour

Scenario Report

Scenario: AM-3Lane
 Command: AM-3Lane
 Volume: AM
 Geometry: 3-Lane
 Impact Fee: Default Impact Fee
 Trip Generation: Default Trip Generation
 Trip Distribution: Default Trip Distribution
 Paths: Default Paths
 Routes: Default Routes
 Configuration: Default Configuration

Kittelson & Associates, Inc. Project #6743
 Milton-Freewater STP and TSP Update - Milton-Freewater, OR
 2025 Three-Lane Alternative, Weekday PM Peak Hour

Impact Analysis Report
Level Of Service

Intersection	Base		Future		Change in
	LOS	Veh C	LOS	Veh C	
# 1 OR 11/ 14th Ave	F	74.5 0.000	F	74.5 0.000	+ 0.000 D/V
# 2 Main Street-OR11/ 12th Ave	F	152.9 0.000	F	152.9 0.000	+ 0.000 D/V
# 3 Main Street - OR 11/ 10th Ave	E	36.4 0.000	E	36.4 0.000	+ 0.000 D/V
# 4 Main Street - OR 11/ 9th Ave	E	49.5 0.000	E	49.5 0.000	+ 0.000 D/V
# 5 Main Street-OR11/ 8th Ave	F	76.8 0.000	F	76.8 0.000	+ 0.000 D/V
# 6 OR 11/7th Ave - Eastbound	F	86.4 0.000	F	86.4 0.000	+ 0.000 D/V
# 7 OR 11/7th Avenue - Westbound	D	33.7 0.000	D	33.7 0.000	+ 0.000 D/V
# 8 OR 11/ 4th Avenue	F	97.8 0.000	F	97.8 0.000	+ 0.000 D/V
# 9 Main Street/OR11/ 2nd Ave	C	23.6 0.552	C	23.6 0.552	+ 0.000 D/V

Kittelson & Associates, Inc. Project #6743
Milton-Freewater STP and TSP Update - Milton-Freewater, OR
2025 Three-Lane Alternative, Weekday PM Peak Hour

Level Of Service Computation Report
2000 HCM Unsignalized Method (Base Volume Alternative)

Intersection #1 OR 11/ 14th Ave

Average Delay (sec/veh): 13.7 Worst Case Level Of Service: F [74.5]

Table with 4 columns: North Bound, South Bound, East Bound, West Bound. Rows include Approach, Movement, Control, Rights, Lanes.

Table with 10 columns: Volume Module, Count, Date, Base Vol, Growth Adj, Initial Bse, User Adj, PHF Adj, PHF Volume, Reduct Vol, Final Vol.

Table with 10 columns: Critical Gap Module, Critical Gp, FollowUpTim.

Table with 10 columns: Capacity Module, Conflict Vol, Potent Cap., Move Cap., Volume/Cap.

Table with 10 columns: Level Of Service Module, Queue, Stopped Del, LOS by Move, Movement, Shared Cap., Shared Queue, Shrd StpDel, Shared LOS, ApproachDel, ApproachLOS.

Kittelson & Associates, Inc. Project #6743
Milton-Freewater STP and TSP Update - Milton-Freewater, OR
2025 Three-Lane Alternative, Weekday PM Peak Hour

Level Of Service Computation Report
2000 HCM Unsignalized Method (Base Volume Alternative)

Intersection #2 Main Street-OR11/ 12th Ave

Average Delay (sec/veh): 7.1 Worst Case Level Of Service: F [152.9]

Table with 4 columns: North Bound, South Bound, East Bound, West Bound. Rows include Approach, Movement, Control, Rights, Lanes.

Table with 10 columns: Volume Module, Count, Date, Base Vol, Growth Adj, Initial Bse, User Adj, PHF Adj, PHF Volume, Reduct Vol, Final Vol.

Table with 10 columns: Critical Gap Module, Critical Gp, FollowUpTim.

Table with 10 columns: Capacity Module, Conflict Vol, Potent Cap., Move Cap., Volume/Cap.

Table with 10 columns: Level Of Service Module, Queue, Stopped Del, LOS by Move, Movement, Shared Cap., Shared Queue, Shrd StpDel, Shared LOS, ApproachDel, ApproachLOS.

Kittelson & Associates, Inc. Project #6743
Milton-Freewater STP and TSP Update - Milton-Freewater, OR
2025 Three-Lane Alternative, Weekday PM Peak Hour

Level Of Service Computation Report
2000 HCM Unsignalized Method (Base Volume Alternative)

Intersection #3 Main Street - OR 11/ 10th Ave

Average Delay (sec/veh): 0.8 Worst Case Level Of Service: E [36.4]

Table with 4 columns: North Bound, South Bound, East Bound, West Bound. Rows include Movement, Control, Rights, Lanes.

Table with 4 columns: North Bound, South Bound, East Bound, West Bound. Rows include Volume Module, Base Vol, Growth Adj, Initial Bse, User Adj, PHF Adj, PHF Volume, Reduct Vol, Final Vol.

Table with 4 columns: North Bound, South Bound, East Bound, West Bound. Rows include Critical Gap Module, Critical Gp, FollowUpTim.

Table with 4 columns: North Bound, South Bound, East Bound, West Bound. Rows include Capacity Module, Conflict Vol, Potent Cap., Move Cap., Volume/Cap.

Table with 4 columns: North Bound, South Bound, East Bound, West Bound. Rows include Level Of Service Module, Queue, Stopped Del, LOS by Move, Movement, Shared Cap., Shared Queue, Shrd StpDel, Shared LOS, ApproachDel, ApproachLOS.

Kittelson & Associates, Inc. Project #6743
Milton-Freewater STP and TSP Update - Milton-Freewater, OR
2025 Three-Lane Alternative, Weekday PM Peak Hour

Level Of Service Computation Report
2000 HCM Unsignalized Method (Base Volume Alternative)

Intersection #4 Main Street - OR 11/ 9th Ave

Average Delay (sec/veh): 1.4 Worst Case Level Of Service: E [49.5]

Table with 4 columns: North Bound, South Bound, East Bound, West Bound. Rows include Movement, Control, Rights, Lanes.

Table with 4 columns: North Bound, South Bound, East Bound, West Bound. Rows include Volume Module, Base Vol, Growth Adj, Initial Bse, User Adj, PHF Adj, PHF Volume, Reduct Vol, Final Vol.

Table with 4 columns: North Bound, South Bound, East Bound, West Bound. Rows include Critical Gap Module, Critical Gp, FollowUpTim.

Table with 4 columns: North Bound, South Bound, East Bound, West Bound. Rows include Capacity Module, Conflict Vol, Potent Cap., Move Cap., Volume/Cap.

Table with 4 columns: North Bound, South Bound, East Bound, West Bound. Rows include Level Of Service Module, Queue, Stopped Del, LOS by Move, Movement, Shared Cap., Shared Queue, Shrd StpDel, Shared LOS, ApproachDel, ApproachLOS.

Kittelson & Associates, Inc. Project #6743
Milton-Freewater STP and TSP Update - Milton-Freewater, OR
2025 Three-Lane Alternative, Weekday PM Peak Hour

Level Of Service Computation Report
2000 HCM Unsignalized Method (Base Volume Alternative)

Intersection #5 Main Street-DR11/ 8th Ave

Average Delay (sec/veh): 2.9 Worst Case Level Of Service: F [76.8]

Table with columns: Approach, Movement, Control, Rights, Lanes. Rows for North Bound, South Bound, East Bound, West Bound.

Volume Module: >> Count Date: 29 Nov 2004 <<
Base Vol: 8 522 2 3 392 15 25 1 11 2 1 12
Growth Adj: 1.32 1.52 1.32 1.32 1.52 1.32 1.32 1.32 1.32 1.32 1.32 1.32

Critical Gap Module:
Critical Gp: 4.1 xxxx xxxxx 4.1 xxxx xxxxx 7.1 6.5 6.2 7.1 6.5 6.2
FollowUpTim: 2.2 xxxx xxxxx 2.2 xxxx xxxxx 3.5 4.0 3.3 3.5 4.0 3.3

Capacity Module:
Conflict Vol: 699 xxxx xxxxxx 903 xxxx xxxxxx 1632 1624 687 1631 1634 902
Potent Cap.: 898 xxxx xxxxxx 753 xxxx xxxxxx 82 104 450 82 102 339

Level Of Service Module:
Queue: 0.0 xxxx xxxxxx 0.0 xxxx xxxxxx xxxxx xxxxx xxxxx xxxxx xxxxx xxxxx
Stopped Del: 9.1 xxxx xxxxxx 9.8 xxxx xxxxxx xxxxx xxxxx xxxxx xxxxx xxxxx xxxxx

Kittelson & Associates, Inc. Project #6743
Milton-Freewater STP and TSP Update - Milton-Freewater, OR
2025 Three-Lane Alternative, Weekday PM Peak Hour

Level Of Service Computation Report
2000 HCM Unsignalized Method (Base Volume Alternative)

Intersection #6 OR 11/7th Ave - Eastbound

Average Delay (sec/veh): 0.8 Worst Case Level Of Service: F [86.4]

Table with columns: Approach, Movement, Control, Rights, Lanes. Rows for North Bound, South Bound, East Bound, West Bound.

Volume Module:
Base Vol: 2 556 0 0 408 13 7 1 2 0 0 0
Growth Adj: 1.32 1.56 1.32 1.32 1.56 1.32 1.32 1.32 1.32 1.32 1.32 1.32

Critical Gap Module:
Critical Gp: 4.1 xxxx xxxxxx xxxxx xxxxx xxxxx 6.4 6.5 6.2 xxxxx xxxxx xxxxx
FollowUpTim: 2.2 xxxx xxxxxx xxxxx xxxxx xxxxx 3.5 4.0 3.3 xxxxx xxxxx xxxxx

Capacity Module:
Conflict Vol: 932 xxxx xxxxxx xxxxx xxxxx xxxxx 2165 2165 920 xxxxx xxxxx xxxxx
Potent Cap.: 734 xxxx xxxxxx xxxxx xxxxx xxxxx 53 48 331 xxxxx xxxxx xxxxx

Level Of Service Module:
Queue: 0.0 xxxx xxxxxx xxxxx xxxxx xxxxx xxxxx xxxxx xxxxx xxxxx xxxxx
Stopped Del: 9.9 xxxx xxxxxx xxxxx xxxxx xxxxx xxxxx xxxxx xxxxx xxxxx xxxxx

Kittelston & Associates, Inc. Project #6743
Milton-Freewater STP and TSP Update - Milton-Freewater, OR
2025 Three-Lane Alternative, Weekday PM Peak Hour

Level Of Service Computation Report
2000 HCM Unsignalized Method (Base Volume Alternative)

Intersection #7 OR 11/7th Avenue - Westbound

Average Delay (sec/veh): 0.6 Worst Case Level Of Service: D [33.7]

Table with 4 columns: North Bound, South Bound, East Bound, West Bound. Rows include Approach, Movement, Control, Rights, Lanes.

Volume Module table with columns for Base Vol, Growth Adj, Initial Bse, User Adj, PHF Adj, PHF Volume, Reduct Vol, Final Vol.

Critical Gap Module table with columns for Critical Gp, FollowUpTim.

Capacity Module table with columns for Conflict Vol, Potent Cap., Move Cap., Volume/Cap.

Level Of Service Module table with columns for Queue, Stopped Del, LOS by Move, Movement, Shared Cap., Shared Queue, Shrd StpDel, Shared LOS, ApproachDel, ApproachLOS.

Kittelston & Associates, Inc. Project #6743
Milton-Freewater STP and TSP Update - Milton-Freewater, OR
2025 Three-Lane Alternative, Weekday PM Peak Hour

Level Of Service Computation Report
2000 HCM Unsignalized Method (Base Volume Alternative)

Intersection #8 OR 11/ 4th Avenue

Average Delay (sec/veh): 1.0 Worst Case Level Of Service: F [97.8]

Table with 4 columns: North Bound, South Bound, East Bound, West Bound. Rows include Approach, Movement, Control, Rights, Lanes.

Volume Module table with columns for Base Vol, Growth Adj, Initial Bse, User Adj, PHF Adj, PHF Volume, Reduct Vol, Final Vol.

Critical Gap Module table with columns for Critical Gap, FollowUpTim.

Capacity Module table with columns for Conflict Vol, Potent Cap., Move Cap., Volume/Cap.

Level Of Service Module table with columns for Queue, Stopped Del, LOS by Move, Movement, Shared Cap., Shared Queue, Shrd StpDel, Shared LOS, ApproachDel, ApproachLOS.

Kittelson & Associates, Inc. Project #6743
 Milton-Freewater STP and TSP Update - Milton-Freewater, OR
 2025 Three-Lane Alternative, Weekday PM Peak Hour

Level Of Service Computation Report
 2000 HCM Operations Method (Base Volume Alternative)

 Intersection #9 Main Street/OR11/ 2nd Ave

Cycle (sec): 100 Critical Vol./Cap. (X): 0.552
 Loss Time (sec): 12 (Y+R = 4 sec) Average Delay (sec/veh): 23.6
 Optimal Cycle: 44 Level Of Service: C

Approach:	North Bound			South Bound			East Bound			West Bound		
Movement:	L	T	R	L	T	R	L	T	R	L	T	R
Control:	Permitted			Permitted			Split Phase			Split Phase		
Rights:	Ignore			Include			Include			Include		
Min. Green:	0	0	0	0	0	0	0	0	0	0	0	0
Lanes:	0	1	0	0	1	0	0	0	1	0	0	1

Volume Module: >> Count Date: 30 Nov 2004 <<

Base Vol:	14	170	407	0	159	1	7	0	11	262	19	1
Growth Adj:	1.32	1.61	1.61	1.32	1.61	1.32	1.32	1.32	1.32	1.61	1.32	1.32
Initial Bse:	18	274	655	0	256	1	9	0	15	422	25	1
User Adj:	1.00	1.00	0.00	1.00	1.00	1.00	1.00	1.00	1.00	1.00	1.00	1.00
PHF Adj:	0.90	0.90	0.00	0.90	0.90	0.90	0.90	0.90	0.90	0.90	0.90	0.90
PHF Volume:	21	304	0	0	285	1	10	0	16	469	28	1
Reduct Vol:	0	0	0	0	0	0	0	0	0	0	0	0
Reduced Vol:	21	304	0	0	285	1	10	0	16	469	28	1
PCE Adj:	1.00	1.00	0.00	1.00	1.00	1.00	1.00	1.00	1.00	1.00	1.00	1.00
MLF Adj:	1.00	1.00	0.00	1.00	1.00	1.00	1.00	1.00	1.00	1.00	1.00	1.00
Final Vol.:	21	304	0	0	285	1	10	0	16	469	28	1

Saturation Flow Module:

Sat/Lane:	1800	1800	1800	1800	1800	1800	1800	1800	1800	1800	1800	1800
Adjustment:	0.95	0.95	1.00	1.00	0.98	0.98	0.88	1.00	0.88	0.93	0.97	0.97
Lanes:	0.06	0.94	1.00	0.00	0.99	0.01	0.39	0.00	0.61	1.00	0.95	0.05
Final Sat.:	108	1606	1800	0	1753	9	618	0	971	1676	1664	88

Capacity Analysis Module:

Vol/Sat:	0.19	0.19	0.00	0.00	0.16	0.16	0.02	0.00	0.02	0.28	0.02	0.02
Crit Moves:	****			****			****			****		
Green/Cycle:	0.34	0.34	0.00	0.00	0.34	0.34	0.03	0.00	0.03	0.51	0.51	0.51
Volume/Cap:	0.55	0.55	0.00	0.00	0.47	0.47	0.55	0.00	0.55	0.55	0.03	0.03
Delay/Veh:	27.8	27.8	0.0	0.0	26.3	26.3	61.0	0.0	61.0	17.7	12.4	12.4
User DelAdj:	1.00	1.00	1.00	1.00	1.00	1.00	1.00	1.00	1.00	1.00	1.00	1.00
AdjDel/Veh:	27.8	27.8	0.0	0.0	26.3	26.3	61.0	0.0	61.0	17.7	12.4	12.4
HCM2kAvg:	9	9	0	0	7	7	2	0	2	11	0	0

Kittelson & Associates, Inc. #6743
 Milton-Freewater STP and TSP Update - Milton-Freewater, OR
 2025 Three-Lane Alternative, Weekday PM Peak Hou

Scenario Report

Scenario: PM-3Lane
 Command: PM-3Lane
 Volume: PM
 Geometry: 3-Lane
 Impact Fee: Default Impact Fee
 Trip Generation: Default Trip Generation
 Trip Distribution: Default Trip Distribution
 Paths: Default Paths
 Routes: Default Routes
 Configuration: Default Configuration

Kittelson & Associates, Inc. #6743
 Milton-Freewater STP and TSP Update - Milton-Freewater, OR
 2025 Three-Lane Alternative, Weekday PM Peak Hou

Impact Analysis Report
 Level Of Service

Intersection	Base		Future		Change in
	Del/ LOS	V/ Veh	Del/ LOS	V/ Veh	
# 1 OR 11/ 14th Ave	F	66.9 0.000	F	66.9 0.000	+ 0.000 D/V
# 2 Main Street-OR11/ 12th Ave	F	150.4 0.000	F	150.4 0.000	+ 0.000 D/V
# 3 Main Street - OR 11/ 10th Ave	F	237.8 0.000	F	237.8 0.000	+ 0.000 D/V
# 4 Main Street - OR 11/ 9th Ave	F	86.8 0.000	F	86.8 0.000	+ 0.000 D/V
# 5 Main Street-OR11/ 8th Ave	F	442.6 0.000	F	442.6 0.000	+ 0.000 D/V
# 6 OR 11/7th Ave - Eastbound	F	250.8 0.000	F	250.8 0.000	+ 0.000 D/V
# 7 OR 11/7th Avenue - Westbound	C	24.4 0.000	C	24.4 0.000	+ 0.000 D/V
# 8 OR 11/ 4th Avenue	F	144.3 0.000	F	144.3 0.000	+ 0.000 D/V
# 9 Main Street/OR11/ 2nd Ave	C	31.9 0.811	C	31.9 0.811	+ 0.000 D/V

Kittelson & Associates, Inc. #6743
Milton-Freewater STP and TSP Update - Milton-Freewater, OR
2025 Three-Lane Alternative, Weekday PM Peak Hou

Level Of Service Computation Report

2000 HCM Unsignalized Method (Base Volume Alternative)

Intersection #1 OR 11/ 14th Ave

Average Delay (sec/veh): 10.2 Worst Case Level Of Service: F [66.9]

Table with 4 columns: Approach, Movement, Control, Rights, Lanes. Rows for North Bound, South Bound, East Bound, West Bound.

Table with 4 columns: Volume Module, Count, Date, and 4 sub-columns for each approach. Rows for Base Vol, Growth Adj, Initial Bse, User Adj, PHF Adj, PHF Volume, Reduct Vol, Final Vol.

Table with 4 columns: Critical Gap Module, Critical Gp, FollowUpTim, and 4 sub-columns for each approach. Rows for Critical Gap Module, Critical Gp, FollowUpTim.

Table with 4 columns: Capacity Module, Conflict Vol, Potent Cap., Move Cap., Volume/Cap, and 4 sub-columns for each approach. Rows for Conflict Vol, Potent Cap., Move Cap., Volume/Cap.

Table with 4 columns: Level Of Service Module, Queue, Stopped Del, LOS by Move, Movement, Shared Cap., Shared Queue, Shrd StpDel, Shared LOS, ApproachDel, ApproachLOS, and 4 sub-columns for each approach. Rows for Queue, Stopped Del, LOS by Move, Movement, Shared Cap., Shared Queue, Shrd StpDel, Shared LOS, ApproachDel, ApproachLOS.

Kittelson & Associates, Inc. #6743
Milton-Freewater STP and TSP Update - Milton-Freewater, OR
2025 Three-Lane Alternative, Weekday PM Peak Hou

Level Of Service Computation Report

2000 HCM Unsignalized Method (Base Volume Alternative)

Intersection #2 Main Street-OR11/ 12th Ave

Average Delay (sec/veh): 3.4 Worst Case Level Of Service: F [150.4]

Table with 4 columns: Approach, Movement, Control, Rights, Lanes. Rows for North Bound, South Bound, East Bound, West Bound.

Table with 4 columns: Volume Module, Count, Date, and 4 sub-columns for each approach. Rows for Base Vol, Growth Adj, Initial Bse, User Adj, PHF Adj, PHF Volume, Reduct Vol, Final Vol.

Table with 4 columns: Critical Gap Module, Critical Gp, FollowUpTim, and 4 sub-columns for each approach. Rows for Critical Gap Module, Critical Gp, FollowUpTim.

Table with 4 columns: Capacity Module, Conflict Vol, Potent Cap., Move Cap., Volume/Cap, and 4 sub-columns for each approach. Rows for Conflict Vol, Potent Cap., Move Cap., Volume/Cap.

Table with 4 columns: Level Of Service Module, Queue, Stopped Del, LOS by Move, Movement, Shared Cap., Shared Queue, Shrd StpDel, Shared LOS, ApproachDel, ApproachLOS, and 4 sub-columns for each approach. Rows for Queue, Stopped Del, LOS by Move, Movement, Shared Cap., Shared Queue, Shrd StpDel, Shared LOS, ApproachDel, ApproachLOS.

Kittelson & Associates, Inc. #6743
Milton-Freewater STP and TSP Update - Milton-Freewater, OR
2025 Three-Lane Alternative, Weekday PM Peak Hou

Level Of Service Computation Report
2000 HCM Unsignalized Method (Base Volume Alternative)

Intersection #3 Main Street - OR 11/ 10th Ave

Average Delay (sec/veh): 5.8 Worst Case Level Of Service: F[237.8]

Table with 4 columns: North Bound, South Bound, East Bound, West Bound. Rows include Control, Rights, Lanes, and Volume Module.

Table with 4 columns: North Bound, South Bound, East Bound, West Bound. Rows include Base Vol, Growth Adj, Initial Bse, User Adj, PHF Adj, PHF Volume, Reduct Vol, Final Vol.

Table with 4 columns: North Bound, South Bound, East Bound, West Bound. Rows include Critical Gap Module, Critical Gp, FollowUpTim.

Table with 4 columns: North Bound, South Bound, East Bound, West Bound. Rows include Capacity Module, Conflict Vol, Potent Cap., Move Cap., Volume/Cap.

Table with 4 columns: North Bound, South Bound, East Bound, West Bound. Rows include Level Of Service Module, Queue, Stopped Del, LOS by Move, Movement, Shared Cap., Shared Queue, Shrd StpDel, Shared LOS, ApproachDel, ApproachLOS.

Kittelson & Associates, Inc. #6743
Milton-Freewater STP and TSP Update - Milton-Freewater, OR
2025 Three-Lane Alternative, Weekday PM Peak Hou

Level Of Service Computation Report
2000 HCM Unsignalized Method (Base Volume Alternative)

Intersection #4 Main Street - OR 11/ 9th Ave

Average Delay (sec/veh): 2.2 Worst Case Level Of Service: F[86.8]

Table with 4 columns: North Bound, South Bound, East Bound, West Bound. Rows include Control, Rights, Lanes, and Volume Module.

Table with 4 columns: North Bound, South Bound, East Bound, West Bound. Rows include Base Vol, Growth Adj, Initial Bse, User Adj, PHF Adj, PHF Volume, Reduct Vol, Final Vol.

Table with 4 columns: North Bound, South Bound, East Bound, West Bound. Rows include Critical Gap Module, Critical Gp, FollowUpTim.

Table with 4 columns: North Bound, South Bound, East Bound, West Bound. Rows include Capacity Module, Conflict Vol, Potent Cap., Move Cap., Volume/Cap.

Table with 4 columns: North Bound, South Bound, East Bound, West Bound. Rows include Level Of Service Module, Queue, Stopped Del, LOS by Move, Movement, Shared Cap., Shared Queue, Shrd StpDel, Shared LOS, ApproachDel, ApproachLOS.

Kittelston & Associates, Inc. #6743
Milton-Freewater STP and TSP Update - Milton-Freewater, OR
2025 Three-Lane Alternative, Weekday PM Peak Hou

Level Of Service Computation Report
2000 HCM Unsignalized Method (Base Volume Alternative)

Intersection #5 Main Street-OR11/ 8th Ave

Average Delay (sec/veh): 11.2 Worst Case Level Of Service: F[442.6]

Table with 4 columns: North Bound, South Bound, East Bound, West Bound. Rows include Approach, Movement, Control, Rights, Lanes.

Volume Module: >> Count Date: 29 Nov 2004 <<. Rows include Base Vol, Growth Adj, Initial Bse, User Adj, PHF Adj, PHF Volume, Reduct Vol, Final Vol.

Critical Gap Module. Rows include Critical Gp, FollowUpTim.

Capacity Module. Rows include Conflict Vol, Potent Cap., Move Cap., Volume/Cap.

Level Of Service Module. Rows include Queue, Stopped Del, LOS by Move, Movement, Shared Cap., Shared Queue, Shrd StpDel, Shared LOS, ApproachDel, ApproachLOS.

Kittelston & Associates, Inc. #6743
Milton-Freewater STP and TSP Update - Milton-Freewater, OR
2025 Three-Lane Alternative, Weekday PM Peak Hou

Level Of Service Computation Report
2000 HCM Unsignalized Method (Base Volume Alternative)

Intersection #6 OR 11/7th Ave - Eastbound

Average Delay (sec/veh): 6.4 Worst Case Level Of Service: F[250.8]

Table with 4 columns: North Bound, South Bound, East Bound, West Bound. Rows include Approach, Movement, Control, Rights, Lanes.

Volume Module. Rows include Base Vol, Growth Adj, Initial Bse, User Adj, PHF Adj, PHF Volume, Reduct Vol, Final Vol.

Critical Gap Module. Rows include Critical Gp, FollowUpTim.

Capacity Module. Rows include Conflict Vol, Potent Cap., Move Cap., Volume/Cap.

Level Of Service Module. Rows include Queue, Stopped Del, LOS by Move, Movement, Shared Cap., Shared Queue, Shrd StpDel, Shared LOS, ApproachDel, ApproachLOS.

Kittelson & Associates, Inc. #6743
Milton-Freewater STP and TSP Update - Milton-Freewater, OR
2025 Three-Lane Alternative, Weekday PM Peak Hou

Level of Service Computation Report
2000 HCM Unsignalized Method (Base Volume Alternative)

Intersection #7 OR 11/7th Avenue - Westbound

Average Delay (sec/veh): 0.3 Worst Case Level Of Service: C [24.4]

Table with 4 columns: North Bound, South Bound, East Bound, West Bound. Rows include Movement, Control, Rights, Lanes.

Volume Module table with 12 columns and 8 rows including Base Vol, Growth Adj, Initial Bse, User Adj, PHF Adj, PHF Volume, Reduct Vol, Final Vol.

Critical Gap Module table with 4 columns and 3 rows including Critical Gap, FollowUpTim.

Capacity Module table with 4 columns and 5 rows including Conflict Vol, Potent Cap., Move Cap., Volume/Cap.

Level of Service Module table with 12 columns and 10 rows including Queue, Stopped Del, LOS by Move, Movement, Shared Cap., Shrd StpDel, Shared LOS, ApproachDel, ApproachLOS.

Kittelson & Associates, Inc. #6743
Milton-Freewater STP and TSP Update - Milton-Freewater, OR
2025 Three-Lane Alternative, Weekday PM Peak Hou

Level of Service Computation Report
2000 HCM Unsignalized Method (Base Volume Alternative)

Intersection #8 OR 11/ 4th Avenue

Average Delay (sec/veh): 1.1 Worst Case Level Of Service: F [144.3]

Table with 4 columns: North Bound, South Bound, East Bound, West Bound. Rows include Movement, Control, Rights, Lanes.

Volume Module table with 12 columns and 8 rows including Base Vol, Growth Adj, Initial Bse, User Adj, PHF Adj, PHF Volume, Reduct Vol, Final Vol.

Critical Gap Module table with 4 columns and 3 rows including Critical Gap, FollowUpTim.

Capacity Module table with 4 columns and 5 rows including Conflict Vol, Potent Cap., Move Cap., Volume/Cap.

Level of Service Module table with 12 columns and 10 rows including Queue, Stopped Del, LOS by Move, Movement, Shared Cap., Shrd StpDel, Shared LOS, ApproachDel, ApproachLOS.

Kittelson & Associates, Inc. #6743
 Milton-Freewater STP and TSP Update - Milton-Freewater, OR
 2025 Three-Lane Alternative, Weekday PM Peak Hou

Level Of Service Computation Report
 2000 HCM Operations Method (Base Volume Alternative)

 Intersection #9 Main Street/OR11/ 2nd Ave

Cycle (sec): 100 Critical Vol./Cap. (X): 0.811
 Loss Time (sec): 12 (Y+R = 4 sec) Average Delay (sec/veh): 31.9
 Optimal Cycle: 80 Level Of Service: C

Approach:	North Bound			South Bound			East Bound			West Bound		
Movement:	L	T	R	L	T	R	L	T	R	L	T	R
Control:	Permitted			Permitted			Split Phase			Split Phase		
Rights:	Ignore			Include			Include			Include		
Min. Green:	0	0	0	0	0	0	0	0	0	0	0	0
Lanes:	0	1	0	0	1	0	0	0	1	0	0	1

Volume Module: >> Count Date: 30 Nov 2004 <<

Base Vol:	7	187	398	0	189	12	5	0	9	481	31	6
Growth Adj:	1.32	1.61	1.61	1.32	1.61	1.32	1.32	1.32	1.32	1.61	1.32	1.32
Initial Bse:	9	301	641	0	304	16	7	0	12	775	41	8
User Adj:	1.00	1.00	0.00	1.00	1.00	1.00	1.00	1.00	1.00	1.00	1.00	1.00
PHF Adj:	0.92	0.92	0.00	0.92	0.92	0.92	0.92	0.92	0.92	0.92	0.92	0.92
PHF Volume:	10	327	0	0	331	17	7	0	13	842	44	9
Reduct Vol:	0	0	0	0	0	0	0	0	0	0	0	0
Reduced Vol:	10	327	0	0	331	17	7	0	13	842	44	9
PCE Adj:	1.00	1.00	0.00	1.00	1.00	1.00	1.00	1.00	1.00	1.00	1.00	1.00
MLF Adj:	1.00	1.00	0.00	1.00	1.00	1.00	1.00	1.00	1.00	1.00	1.00	1.00
Final Vol.:	10	327	0	0	331	17	7	0	13	842	44	9

Saturation Flow Module:

Sat/Lane:	1800	1800	1800	1800	1800	1800	1800	1800	1800	1800	1800	1800
Adjustment:	0.97	0.97	1.00	1.00	0.97	0.97	0.88	1.00	0.88	0.93	0.96	0.96
Lanes:	0.03	0.97	1.00	0.00	0.95	0.05	0.36	0.00	0.64	1.00	0.84	0.16
Final Sat.:	52	1696	1800	0	1665	87	565	0	1017	1676	1442	279

Capacity Analysis Module:

Vel/Sat:	0.19	0.19	0.00	0.00	0.20	0.20	0.01	0.00	0.01	0.50	0.03	0.03
Crit Moves:				****			****			****		
Green/Cycle:	0.24	0.24	0.00	0.00	0.24	0.24	0.02	0.00	0.02	0.62	0.62	0.62
Volume/Cap:	0.79	0.79	0.00	0.00	0.81	0.81	0.81	0.00	0.81	0.81	0.05	0.05
Delay/Veh:	44.7	44.7	0.0	0.0	46.7	46.7	149.1	0.0	149.1	19.5	7.5	7.5
User DelAdj:	1.00	1.00	1.00	1.00	1.00	1.00	1.00	1.00	1.00	1.00	1.00	1.00
AdjDel/Veh:	44.7	44.7	0.0	0.0	46.7	46.7	149.1	0.0	149.1	19.5	7.5	7.5
HCM2KAVg:	12	12	0	0	12	12	2	0	2	23	1	1

Traffix 7.7.1115 (c) 2004 Dowling Assoc. Licensed to KITTELSON, PORTLAND

Appendix G

**2004 Traffic Operations
Analysis Worksheets –
Recommended Plan**

Kittelson & Associates, Inc. Project #6743
 Milton-Freewater STP and TSP Update - Milton-Freewater, OR
 2004 Recommended Three-Lane Alternative, Weekday AM Peak Hour

Scenario Report

Scenario: AM-3Lane-Reco
 Command: AM-3Lane-Reco
 Volume: AM
 Geometry: 3-lane-Reco
 Impact Fee: Default Impact Fee
 Trip Generation: Default Trip Generation
 Trip Distribution: Default Trip Distribution
 Paths: Default Paths
 Routes: Default Routes
 Configuration: Default Configuration

Kittelson & Associates, Inc. Project #6743
 Milton-Freewater STP and TSP Update - Milton-Freewater, OR
 2004 Recommended Three-Lane Alternative, Weekday AM Peak Hour

Impact Analysis Report
Level Of Service

Intersection	Base		Future		Change in
	LOS	Veh C	LOS	Veh C	
# 1 OR 11/ 14th Ave	C	17.3 0.000	C	17.3 0.000	+ 0.000 D/V
# 2 Main Street-OR11/ 12th Ave	E	38.4 0.000	E	38.4 0.000	+ 0.000 D/V
# 3 Main Street - OR 11/ 10th Ave	C	21.4 0.000	C	21.4 0.000	+ 0.000 D/V
# 4 Main Street - OR 11/ 9th Ave	D	25.2 0.000	D	25.2 0.000	+ 0.000 D/V
# 5 Main Street-OR11/ 8th Ave	C	17.7 0.000	C	17.7 0.000	+ 0.000 D/V
# 6 OR 11/7th Ave - Eastbound	C	24.5 0.000	C	24.5 0.000	+ 0.000 D/V
# 7 OR 11/7th Avenue - Westbound	B	14.0 0.000	B	14.0 0.000	+ 0.000 D/V
# 8 OR 11/ 4th Avenue	D	26.2 0.000	D	26.2 0.000	+ 0.000 D/V
# 9 Main Street/OR11/ 2nd Ave	C	20.4 0.239	C	20.4 0.239	+ 0.000 D/V

Kittelson & Associates, Inc. Project #6743
Milton-Freewater STP and TSP Update - Milton-Freewater, OR
2004 Recommended Three-Lane Alternative, Weekday AM Peak Hour

Level Of Service Computation Report
2000 HCM Unsignalized Method (Base Volume Alternative)

Intersection #1 OR 11/ 14th Ave

Average Delay (sec/veh): 3.9 Worst Case Level Of Service: C [17.3]

Table with 4 columns: North Bound, South Bound, East Bound, West Bound. Rows include Approach, Movement, Control, Rights, and Lanes.

Volume Module: >> Count Date: 1 Dec 2004 <<. Table with 4 columns and 10 rows of traffic volume data.

Critical Gap Module: Table with 4 columns and 2 rows of critical gap and follow-up time data.

Capacity Module: Table with 4 columns and 4 rows of capacity and volume/capacity data.

Level Of Service Module: Table with 4 columns and 8 rows of queue, stopped delay, LOS, and approach delay data.

Kittelson & Associates, Inc. Project #6743
Milton-Freewater STP and TSP Update - Milton-Freewater, OR
2004 Recommended Three-Lane Alternative, Weekday AM Peak Hour

Level Of Service Computation Report
2000 HCM Unsignalized Method (Base Volume Alternative)

Intersection #2 Main Street-OR11/ 12th Ave

Average Delay (sec/veh): 2.1 Worst Case Level Of Service: E [38.4]

Table with 4 columns: North Bound, South Bound, East Bound, West Bound. Rows include Approach, Movement, Control, Rights, and Lanes.

Volume Module: >> Count Date: 7 Dec 2004 <<. Table with 4 columns and 10 rows of traffic volume data.

Critical Gap Module: Table with 4 columns and 2 rows of critical gap and follow-up time data.

Capacity Module: Table with 4 columns and 4 rows of capacity and volume/capacity data.

Level Of Service Module: Table with 4 columns and 8 rows of queue, stopped delay, LOS, and approach delay data.

Kittelson & Associates, Inc. Project #6743
Milton-Freewater STP and TSP Update - Milton-Freewater, OR
2004 Recommended Three-Lane Alternative, Weekday AM Peak Hour

Level Of Service Computation Report
2000 HCM Unsignalized Method (Base Volume Alternative)

Intersection #3 Main Street - OR 11/ 10th Ave

Average Delay (sec/veh): 0.5 Worst Case Level Of Service: C [21.4]

Table with columns: Approach: North Bound, South Bound, East Bound, West Bound; Movement: L-T-R; Control: Uncontrolled, Stop Sign; Rights: Include; Lanes: 1 0 0 1 0

Volume Module: >> Count Date: 18 Nov 2004 <<
Base Vol: 5 495 1 4 369 8 7 1 5 1 1 11
Growth Adj: 1.00 1.15 1.00 1.00 1.15 1.00 1.00 1.00 1.00 1.00 1.00 1.00

Critical Gap Module:
Critical Gp: 4.1 xxxx xxxxx 4.1 xxxx xxxxx 7.1 6.5 6.2 7.1 6.5 6.2
FollowUpTim: 2.2 xxxx xxxxx 2.2 xxxx xxxxx 3.5 4.0 3.3 3.5 4.0 3.3

Capacity Module:
Cnflct Vol: 491 xxxx xxxxx 648 xxxx xxxxx 1161 1155 487 1158 1159 647
Potent Cap.: 1072 xxxx xxxxx 938 xxxx xxxxx 174 198 585 175 197 474

Level Of Service Module:
Queue: 0.0 xxxx xxxxx 0.0 xxxx xxxxx xxxxx xxxx xxxxx xxxxx xxxx xxxxx
Stopped Del: 8.4 xxxx xxxxx 8.9 xxxx xxxxx xxxxx xxxx xxxxx xxxxx xxxx xxxxx

Kittelson & Associates, Inc. Project #6743
Milton-Freewater STP and TSP Update - Milton-Freewater, OR
2004 Recommended Three-Lane Alternative, Weekday AM Peak Hour

Level Of Service Computation Report
2000 HCM Unsignalized Method (Base Volume Alternative)

Intersection #4 Main Street - OR 11/ 9th Ave

Average Delay (sec/veh): 0.8 Worst Case Level Of Service: D [25.2]

Table with columns: Approach: North Bound, South Bound, East Bound, West Bound; Movement: L-T-R; Control: Uncontrolled, Stop Sign; Rights: Include; Lanes: 1 0 0 1 0

Volume Module: >> Count Date: 22 Dec 2004 <<
Base Vol: 1 508 5 15 371 19 11 1 6 4 1 13
Growth Adj: 1.00 1.22 1.00 1.00 1.22 1.00 1.00 1.00 1.00 1.00 1.00 1.00

Critical Gap Module:
Critical Gp: 4.1 xxxx xxxxx 4.1 xxxx xxxxx 7.1 6.5 6.2 7.1 6.5 6.2
FollowUpTim: 2.2 xxxx xxxxx 2.2 xxxx xxxxx 3.5 4.0 3.3 3.5 4.0 3.3

Capacity Module:
Cnflct Vol: 518 xxxx xxxxx 687 xxxx xxxxx 1234 1230 508 1231 1237 684
Potent Cap.: 1048 xxxx xxxxx 907 xxxx xxxxx 155 179 569 156 177 452

Level Of Service Module:
Queue: 0.0 xxxx xxxxx 0.1 xxxx xxxxx xxxxx xxxx xxxxx xxxxx xxxx xxxxx
Stopped Del: 8.4 xxxx xxxxx 9.0 xxxx xxxxx xxxxx xxxx xxxxx xxxxx xxxx xxxxx

Kittelson & Associates, Inc. Project #6743
Milton-Freewater STP and TSP Update - Milton-Freewater, OR
2004 Recommended Three-Lane Alternative, Weekday AM Peak Hour

Level Of Service Computation Report
2000 HCM Unsignalized Method (Base Volume Alternative)

Intersection #5 Main Street-OR11/ 8th Ave

Average Delay (sec/veh): 0.9 Worst Case Level Of Service: C [17.7]

Table with columns for Approach (North, South, East, West Bound) and Movement (L, T, R). Rows include Control, Rights, Lanes, Volume Module, Base Vol, Growth Adj, Initial Bse, User Adj, PHF Adj, PHF Volume, Reduct Vol, and Final Vol.

Critical Gap Module table with columns for Critical Gap and FollowUpTim.

Capacity Module table with columns for Conflict Vol, Potent Cap, Move Cap, Total Cap, and Volume/Cap.

Level Of Service Module table with columns for Queue, Stopped Del, LOS by Move, Movement, Shared Cap, Shared Queue, Shrd StpDel, Shared LOS, ApproachDel, and ApproachLOS.

Kittelson & Associates, Inc. Project #6743
Milton-Freewater STP and TSP Update - Milton-Freewater, OR
2004 Recommended Three-Lane Alternative, Weekday AM Peak Hour

Level Of Service Computation Report
2000 HCM Unsignalized Method (Base Volume Alternative)

Intersection #6 OR 11/7th Ave - Eastbound

Average Delay (sec/veh): 0.2 Worst Case Level Of Service: C [24.5]

Table with columns for Approach (North, South, East, West Bound) and Movement (L, T, R). Rows include Control, Rights, Lanes, Volume Module, Base Vol, Growth Adj, Initial Bse, User Adj, PHF Adj, PHF Volume, Reduct Vol, and Final Vol.

Critical Gap Module table with columns for Critical Gap and FollowUpTim.

Capacity Module table with columns for Conflict Vol, Potent Cap, Move Cap, Volume/Cap.

Level Of Service Module table with columns for Queue, Stopped Del, LOS by Move, Movement, Shared Cap, Shared Queue, Shrd StpDel, Shared LOS, ApproachDel, and ApproachLOS.

Kittelson & Associates, Inc. Project #6743
Milton-Freewater STP and TSP Update - Milton-Freewater, OR
2004 Recommended Three-Lane Alternative, Weekday AM Peak Hour

Level Of Service Computation Report
2000 HCM Unsignalized Method (Base Volume Alternative)

Intersection #7 OR 11/7th Avenue - Westbound

Average Delay (sec/veh): 0.3 Worst Case Level Of Service: B [14.0]

Table with columns: Approach, Movement, Control, Rights, Lanes. Rows for North Bound, South Bound, East Bound, West Bound.

Volume Module table with columns: Base Vol, Growth Adj, Initial Bse, User Adj, PHF Adj, PHF Volume, Reduct Vol, Final Vol. Rows for North, South, East, West.

Critical Gap Module table with columns: Critical Gp, FollowUpTim. Rows for North, South, East, West.

Capacity Module table with columns: Conflict Vol, Potent Cap., Move Cap., Volume/Cap. Rows for North, South, East, West.

Level Of Service Module table with columns: Queue, Stopped Del, LOS by Move, Movement, Shared Cap., Shared Queue, Shrd StpDel, Shared LOS, ApproachDel, ApproachLOS. Rows for North, South, East, West.

Kittelson & Associates, Inc. Project #6743
Milton-Freewater STP and TSP Update - Milton-Freewater, OR
2004 Recommended Three-Lane Alternative, Weekday AM Peak Hour

Level Of Service Computation Report
2000 HCM Unsignalized Method (Base Volume Alternative)

Intersection #8 OR 11/ 4th Avenue

Average Delay (sec/veh): 0.4 Worst Case Level Of Service: D [26.2]

Table with columns: Approach, Movement, Control, Rights, Lanes. Rows for North Bound, South Bound, East Bound, West Bound.

Volume Module table with columns: Base Vol, Growth Adj, Initial Bse, User Adj, PHF Adj, PHF Volume, Reduct Vol, Final Vol. Rows for North, South, East, West.

Critical Gap Module table with columns: Critical Gap, FollowUpTim. Rows for North, South, East, West.

Capacity Module table with columns: Conflict Vol, Potent Cap., Move Cap., Volume/Cap. Rows for North, South, East, West.

Level Of Service Module table with columns: Queue, Stopped Del, LOS by Move, Movement, Shared Cap., Shared Queue, Shrd StpDel, Shared LOS, ApproachDel, ApproachLOS. Rows for North, South, East, West.

Kittelson & Associates, Inc. Project #6743
Milton-Freewater STP and TSP Update - Milton-Freewater, OR
2004 Recommended Three-Lane Alternative, Weekday AM Peak Hour

Level Of Service Computation Report
2000 HCM Operations Method (Base Volume Alternative)

Intersection #9 Main Street/OR11/ 2nd Ave

Cycle (sec): 100 Critical Vol./Cap. (X): 0.239
Loss Time (sec): 12 (Y+R = 4 sec) Average Delay (sec/veh): 20.4
Optimal Cycle: 29 Level Of Service: C

Approach:	North Bound			South Bound			East Bound			West Bound		
Movement:	L	T	R	L	T	R	L	T	R	L	T	R
Control:	Permitted			Permitted			Split Phase			Split Phase		
Rights:	Ignore			Include			Include			Include		
Min. Green:	0	0	0	0	0	0	0	0	0	0	0	0
Lanes:	0	1	1	0	0	1	0	0	1	1	0	1

Volume Module: >> Count Date: 30 Nov 2004 <<

	14	170	407	0	159	1	7	0	11	262	19	1
Base Vol:	14	170	407	0	159	1	7	0	11	262	19	1
Growth Adj:	1.00	1.22	1.22	1.00	1.22	1.00	1.00	1.00	1.00	1.22	1.00	1.00
Initial Bse:	14	207	497	0	194	1	7	0	11	320	19	1
User Adj:	1.00	1.00	0.00	1.00	1.00	1.00	1.00	1.00	1.00	1.00	1.00	1.00
PHF Adj:	0.90	0.90	0.00	0.90	0.90	0.90	0.90	0.90	0.90	0.90	0.90	0.90
PHF Volume:	16	230	0	0	216	1	8	0	12	355	21	1
Reduct Vol:	0	0	0	0	0	0	0	0	0	0	0	0
Reduced Vol:	16	230	0	0	216	1	8	0	12	355	21	1
PCE Adj:	1.00	1.00	0.00	1.00	1.00	1.00	1.00	1.00	1.00	1.00	1.00	1.00
MLF Adj:	1.00	1.00	0.00	1.00	1.00	1.00	1.00	1.00	1.00	1.00	1.00	1.00
Final Vol.:	16	230	0	0	216	1	8	0	12	355	21	1

Saturation Flow Module:

Sat/Lane:	1800	1800	1800	1800	1800	1800	1800	1800	1800	1800	1800	1800
Adjustment:	0.87	0.87	1.00	1.00	0.93	0.93	0.88	1.00	0.88	0.94	0.94	0.94
Lanes:	0.13	1.87	1.00	0.00	1.99	0.01	0.39	0.00	0.61	1.89	0.10	0.01
Final Sat.:	198	2926	1800	0	3331	17	618	0	971	3182	178	9

Capacity Analysis Module:

Vol/Sat:	0.08	0.08	0.00	0.00	0.06	0.06	0.01	0.00	0.01	0.11	0.12	0.12
Crit Moves:	****			****			****			****		
Green/Cycle:	0.33	0.33	0.00	0.00	0.33	0.33	0.05	0.00	0.05	0.50	0.50	0.50
Volume/Cap:	0.24	0.24	0.00	0.00	0.20	0.20	0.24	0.00	0.24	0.22	0.24	0.24
Delay/Veh:	24.5	24.5	0.0	0.0	24.1	24.1	46.9	0.0	46.9	14.3	14.4	14.4
User DelAdj:	1.00	1.00	1.00	1.00	1.00	1.00	1.00	1.00	1.00	1.00	1.00	1.00
AdjDel/Veh:	24.5	24.5	0.0	0.0	24.1	24.1	46.9	0.0	46.9	14.3	14.4	14.4
HCH2kAvg:	3	3	0	0	2	2	1	0	1	3	4	4

Kittelson & Associates, Inc. Project #6743
 Milton-Freewater STP and TSP Update - Milton-Freewater, OR
 2004 Recommended Three-Lane Alternative, Weekday PM Peak Hour

Scenario Report

Scenario: PM-3Lane-Reco

Command: PM-3Lane-Reco
 Volume: PM
 Geometry: 3-lane-Reco
 Impact Fee: Default Impact Fee
 Trip Generation: Default Trip Generation
 Trip Distribution: Default Trip Distribution
 Paths: Default Paths
 Routes: Default Routes
 Configuration: Default Configuration

Kittelson & Associates, Inc. Project #6743
 Milton-Freewater STP and TSP Update - Milton-Freewater, OR
 2004 Recommended Three-Lane Alternative, Weekday PM Peak Hour

Impact Analysis Report
 Level Of Service

Intersection	Base		Future		Change in
	LOS	Del/Veh C	LOS	Del/Veh C	
# 1 OR 11/ 14th Ave	C	16.9 0.000	C	16.9 0.000	+ 0.000 D/V
# 2 Main Street-OR11/ 12th Ave	E	44.8 0.000	E	44.8 0.000	+ 0.000 D/V
# 3 Main Street - OR 11/ 10th Ave	F	52.4 0.000	F	52.4 0.000	+ 0.000 D/V
# 4 Main Street - OR 11/ 9th Ave	D	34.6 0.000	D	34.6 0.000	+ 0.000 D/V
# 5 Main Street-OR11/ 8th Ave	D	25.4 0.000	D	25.4 0.000	+ 0.000 D/V
# 6 OR 11/7th Ave - Eastbound	D	34.6 0.000	D	34.6 0.000	+ 0.000 D/V
# 7 OR 11/7th Avenue - Westbound	B	12.4 0.000	B	12.4 0.000	+ 0.000 D/V
# 8 OR 11/ 4th Avenue	D	34.8 0.000	D	34.8 0.000	+ 0.000 D/V
# 9 Main Street/OR11/ 2nd Ave	B	19.6 0.345	B	19.6 0.345	+ 0.000 D/V

Kittelson & Associates, Inc. Project #6743
Milton-Freewater STP and TSP Update - Milton-Freewater, OR
2004 Recommended Three-Lane Alternative, Weekday PM Peak Hour

Level Of Service Computation Report
2000 HCM Unsignalized Method (Base Volume Alternative)

Intersection #1 OR 11/ 14th Ave

Average Delay (sec/veh): 3.5 Worst Case Level Of Service: C [16.9]

Table with columns: Approach, Movement, Control, Rights, Lanes. Rows for North Bound, South Bound, East Bound, West Bound.

Volume Module: >> Count Date: 1 Dec 2004 <<
Base Vol: 0 333 6 145 339 0 0 0 0 0 8 0 134
Growth Adj: 1.00 1.18 1.00 1.00 1.18 1.00 1.00 1.00 1.00 1.00 1.00 1.00

Critical Gap Module:
Critical Gp: 4.1 xxxx xxxxx xxxxx xxxx xxxxx 6.4 xxxx 6.2
FollowUpTim: 2.2 xxxx xxxxx xxxxx xxxx xxxxx 3.5 xxxx 3.3

Capacity Module:
Conflict Vol: 562 xxxx xxxxx xxxx xxxx xxxxx 1530 xxxx 558
Potent Cap.: 1009 xxxx xxxxx xxxx xxxx xxxxx 130 xxxx 533

Level Of Service Module:
Queue: 0.8 xxxx xxxxx xxxxx xxxx xxxxx 0.3 xxxx 1.6
Stopped Del: 9.5 xxxx xxxxx xxxxx xxxx xxxxx 41.4 xxxx 15.4

Kittelson & Associates, Inc. Project #6743
Milton-Freewater STP and TSP Update - Milton-Freewater, OR
2004 Recommended Three-Lane Alternative, Weekday PM Peak Hour

Level Of Service Computation Report
2000 HCM Unsignalized Method (Base Volume Alternative)

Intersection #2 Main Street-OR11/ 12th Ave

Average Delay (sec/veh): 1.3 Worst Case Level Of Service: E [44.8]

Table with columns: Approach, Movement, Control, Rights, Lanes. Rows for North Bound, South Bound, East Bound, West Bound.

Volume Module: >> Count Date: 7 Dec 2004 <<
Base Vol: 1 466 1 37 482 21 18 3 1 2 2 11
Growth Adj: 1.00 1.18 1.00 1.00 1.18 1.00 1.00 1.00 1.00 1.00 1.00

Critical Gap Module:
Critical Gp: 4.1 xxxx xxxxx 4.1 xxxx xxxxx 7.1 6.5 6.2 7.1 6.5 6.2
FollowUpTim: 2.2 xxxx xxxxx 2.2 xxxx xxxxx 3.5 4.0 3.3 3.5 4.0 3.3

Capacity Module:
Conflict Vol: 686 xxxx xxxxx 641 xxxx xxxxx 1409 1402 674 1404 1414 640
Potent Cap.: 908 xxxx xxxxx 944 xxxx xxxxx 117 141 458 118 139 479

Level Of Service Module:
Queue: 0.0 xxxx xxxxx 0.1 xxxx xxxxx xxxxx xxxx xxxxx xxxxx xxxx xxxxx
Stopped Del: 9.0 xxxx xxxxx 9.0 xxxx xxxxx xxxxx xxxx xxxxx xxxxx xxxx xxxxx

Kittelson & Associates, Inc. Project #6743
Milton-Freewater STP and TSP Update - Milton-Freewater, OR
2004 Recommended Three-Lane Alternative, Weekday PM Peak Hour

Level Of Service Computation Report
2000 HCM Unsignalized Method (Base Volume Alternative)

Intersection #3 Main Street - OR 11/ 10th Ave

Average Delay (sec/veh): 1.6 Worst Case Level Of Service: F (52.4)

Table with 4 columns: North Bound, South Bound, East Bound, West Bound. Rows include Approach, Movement, Control, Rights, Lanes.

Volume Module: >> Count Date: 18 Nov 2004 <<. Base Vol, Growth Adj, Initial Bse, User Adj, PHF Adj, PHF Volume, Reduct Vol, Final Vol.

Critical Gap Module: Critical Gp, FollowUpTim.

Capacity Module: Conflict Vol, Potent Cap., Move Cap., Volume/Cap.

Level Of Service Module: Queue, Stopped Del, LOS by Move, Movement, Shared Cap., Shared Queue, Shrd StpDel, Shared LOS, ApproachDel, ApproachLOS.

Kittelson & Associates, Inc. Project #6743
Milton-Freewater STP and TSP Update - Milton-Freewater, OR
2004 Recommended Three-Lane Alternative, Weekday PM Peak Hour

Level Of Service Computation Report
2000 HCM Unsignalized Method (Base Volume Alternative)

Intersection #4 Main Street - OR 11/ 9th Ave

Average Delay (sec/veh): 1.0 Worst Case Level Of Service: D (34.6)

Table with 4 columns: North Bound, South Bound, East Bound, West Bound. Rows include Approach, Movement, Control, Rights, Lanes.

Volume Module: >> Count Date: 22 Nov 2004 <<. Base Vol, Growth Adj, Initial Bse, User Adj, PHF Adj, PHF Volume, Reduct Vol, Final Vol.

Critical Gap Module: Critical Gp, FollowUpTim.

Capacity Module: Conflict Vol, Potent Cap., Move Cap., Volume/Cap.

Level Of Service Module: Queue, Stopped Del, LOS by Move, Movement, Shared Cap., Shared Queue, Shrd StpDel, Shared LOS, ApproachDel, ApproachLOS.

Kittelson & Associates, Inc. Project #6743
Milton-Freewater STP and TSP Update - Milton-Freewater, OR
2004 Recommended Three-Lane Alternative, Weekday PM Peak Hour

Level Of Service Computation Report
2000 HCM Unsignalized Method (Base Volume Alternative)

Intersection #5 Main Street-OR11/ 8th Ave

Average Delay (sec/veh): 0.8 Worst Case Level Of Service: D [25.4]

Table with 4 columns: Approach (North Bound, South Bound, East Bound, West Bound), Movement (L-T-R), Control (Uncontrolled, Stop Sign), Rights (Include), Lanes (1 0 0 1 0)

Volume Module: >> Count Date: 29 Nov 2004 <<
Base Vol: 6 527 9 13 578 43 24 3 6 3 1 1 1
Growth Adj: 1.00 1.15 1.00 1.00 1.15 1.00 1.00 1.00 1.00 1.00 1.00 1.00

Critical Gap Module:
Critical Gp: 4.1 xxxx xxxxx 4.1 xxxx xxxxx 7.1 6.5 6.2 7.1 6.5 6.2
FollowUpTim: 2.2 xxxx xxxxx 2.2 xxxx xxxxx 3.5 4.0 3.3 3.5 4.0 3.3

Capacity Module:
Conflict Vol: 874 xxxx xxxxx 759 xxxx xxxxx 1649 1653 847 1653 1674 754
Potent Cap.: 772 xxxx xxxxx 852 xxxx xxxxx 80 99 365 79 96 413

Level Of Service Module:
Queue: 0.0 xxxx xxxxx 0.1 xxxx xxxxx xxxxx xxxxx xxxxx xxxxx xxxxx xxxxx
Stopped Del: 9.7 xxxx xxxxx 9.3 xxxx xxxxx xxxxx xxxxx xxxxx xxxxx xxxxx xxxxx
LOS by Move: A * * A * * A * * A * * A * * A * * A * *
Movement: LT - LTR - RT LT - LTR - RT LT - LTR - RT LT - LTR - RT

Kittelson & Associates, Inc. Project #6743
Milton-Freewater STP and TSP Update - Milton-Freewater, OR
2004 Recommended Three-Lane Alternative, Weekday PM Peak Hour

Level Of Service Computation Report
2000 HCM Unsignalized Method (Base Volume Alternative)

Intersection #6 OR 11/7th Ave - Eastbound

Average Delay (sec/veh): 0.9 Worst Case Level Of Service: D [34.6]

Table with 4 columns: Approach (North Bound, South Bound, East Bound, West Bound), Movement (L-T-R), Control (Uncontrolled, Stop Sign), Rights (Include), Lanes (0 1 0 1 0)

Volume Module:
Base Vol: 6 544 0 0 631 20 31 3 3 0 0 0
Growth Adj: 1.00 1.18 1.00 1.00 1.18 1.00 1.00 1.00 1.00 1.00 1.00 1.00

Critical Gap Module:
Critical Gp: 4.1 xxxx xxxxx xxxxx xxxxx xxxxx 6.8 6.5 6.9 xxxxx xxxxx xxxxx
FollowUpTim: 2.2 xxxx xxxxx xxxxx xxxxx xxxxx 3.5 4.0 3.3 xxxxx xxxxx xxxxx

Capacity Module:
Conflict Vol: 889 xxxx xxxxx xxxx xxxx xxxxx 1265 1638 445 xxxx xxxx xxxxx
Potent Cap.: 758 xxxx xxxxx xxxx xxxx xxxxx 164 102 567 xxxx xxxx xxxxx

Level Of Service Module:
Queue: 0.0 xxxx xxxxx xxxxx xxxx xxxxx xxxxx xxxx xxxxx xxxxx xxxx xxxxx
Stopped Del: 9.8 xxxx xxxxx xxxxx xxxx xxxxx xxxxx xxxx xxxxx xxxxx xxxx xxxxx
LOS by Move: A * * * * * A * * * * * A * * * * * A * * * * *
Movement: LT - LTR - RT LT - LTR - RT LT - LTR - RT LT - LTR - RT

Kittelson & Associates, Inc. Project #6743
Milton-Freewater STP and TSP Update - Milton-Freewater, OR
2004 Recommended Three-Lane Alternative, Weekday PM Peak Hour

Level Of Service Computation Report
2000 HCM Unsignalized Method (Base Volume Alternative)

Intersection #7 OR 11/7th Avenue - Westbound

Average Delay (sec/veh): 0.2 Worst Case Level Of Service: B [12.4]

Table with 4 columns: North Bound, South Bound, East Bound, West Bound. Rows include Approach, Movement, Control, Rights, Lanes.

Volume Module:

Table with 10 columns for traffic movements and 4 rows: Base Vol, Growth Adj, Initial Bse, User Adj, PHF Adj, PHF Volume, Reduct Vol, Final Vol.

Critical Gap Module:

Table with 4 columns for movements and 2 rows: Critical Gap, FollowUpTime.

Capacity Module:

Table with 4 columns for movements and 4 rows: Conflict Vol, Potent Cap., Move Cap., Volume/Cap.

Level Of Service Module:

Table with 10 columns for movements and 6 rows: Queue, Stopped Del, LOS by Move, Movement, Shared Cap., Shared Queue, Shrd StpDel, Shared LOS, ApproachDel, ApproachLOS.

Kittelson & Associates, Inc. Project #6743
Milton-Freewater STP and TSP Update - Milton-Freewater, OR
2004 Recommended Three-Lane Alternative, Weekday PM Peak Hour

Level Of Service Computation Report
2000 HCM Unsignalized Method (Base Volume Alternative)

Intersection #8 OR 11/ 4th Avenue

Average Delay (sec/veh): 0.4 Worst Case Level Of Service: D [34.8]

Table with 4 columns: North Bound, South Bound, East Bound, West Bound. Rows include Approach, Movement, Control, Rights, Lanes.

Volume Module:

Table with 10 columns for traffic movements and 4 rows: Base Vol, Growth Adj, Initial Bse, User Adj, PHF Adj, PHF Volume, Reduct Vol, Final Vol.

Critical Gap Module:

Table with 4 columns for movements and 2 rows: Critical Gap, FollowUpTime.

Capacity Module:

Table with 4 columns for movements and 4 rows: Conflict Vol, Potent Cap., Move Cap., Volume/Cap.

Level Of Service Module:

Table with 10 columns for movements and 6 rows: Queue, Stopped Del, LOS by Move, Movement, Shared Cap., Shared Queue, Shrd StpDel, Shared LOS, ApproachDel, ApproachLOS.

Kittelson & Associates, Inc. Project #6743
Milton-Freewater STP and TSP Update - Milton-Freewater, OR
2004 Recommended Three-Lane Alternative, Weekday PM Peak Hour

Level Of Service Computation Report
2000 HCM Operations Method (Base Volume Alternative)

Intersection #9 Main Street/OR11/ 2nd Ave

Cycle (sec): 100 Critical Vol./Cap. (X): 0.345
Loss Time (sec): 12 (Y+R = 4 sec) Average Delay (sec/veh): 19.6
Optimal Cycle: 33 Level Of Service: B

Table with 4 columns: North Bound, South Bound, East Bound, West Bound. Rows include Movement (L-T-R), Control Rights, Min. Green, and Lanes.

Volume Module: >> Count Date: 30 Nov 2004 <<
Base Vol: 7 187 398 0 189 12 5 0 9 481 31 6
Growth Adj: 1.00 1.22 1.22 1.00 1.22 1.00 1.00 1.00 1.00 1.22 1.00 1.00

Saturation Flow Module:
Sat/Lane: 1800 1800 1800 1800 1800 1800 1800 1800 1800 1800
Adjustment: 0.88 0.88 1.00 1.00 0.92 0.92 0.88 1.00 0.88 0.93 0.93 0.93

Capacity Analysis Module:
Vol/Sat: 0.08 0.08 0.00 0.00 0.08 0.08 0.01 0.00 0.01 0.20 0.21 0.21
Crit Moves: ****
Green/Cycle: 0.23 0.23 0.00 0.00 0.23 0.23 0.03 0.00 0.03 0.62 0.62 0.62

Appendix H

**2025 Traffic Operations
Analysis Worksheets –
Recommended Plan**

Kittelson & Associates, Inc. - Project #6743
 Milton-Freewater STA and TSP Update - Milton-Freewater, OR
 2025 Recommended Three-Lane Traffic Condition, Weekday AM Peak Hour

Scenario Report
 Scenario: AM-3Lane-Reco
 Command: AM-3Lane-Reco
 Volume: AM
 Geometry: 3-lane-Reco
 Impact Fee: Default Impact Fee
 Trip Generation: Default Trip Generation
 Trip Distribution: Default Trip Distribution
 Paths: Default Paths
 Routes: Default Routes
 Configuration: Default Configuration

Kittelson & Associates, Inc. - Project #6743
 Milton-Freewater STA and TSP Update - Milton-Freewater, OR
 2025 Recommended Three-Lane Traffic Condition, Weekday AM Peak Hour

Impact Analysis Report
 Level Of Service

Intersection	Base		Future		Change in
	Del/ LOS	V/ Veh	Del/ LOS	V/ Veh	
# 1 OR 11/ 14th Ave	D	31.9 0.000	D	31.9 0.000	+ 0.000 D/V
# 2 Main Street-OR11/ 12th Ave	F	152.9 0.000	F	152.9 0.000	+ 0.000 D/V
# 3 Main Street - OR 11/ 10th Ave	E	36.4 0.000	E	36.4 0.000	+ 0.000 D/V
# 4 Main Street - OR 11/ 9th Ave	E	49.5 0.000	E	49.5 0.000	+ 0.000 D/V
# 5 Main Street-OR11/ 8th Ave	D	25.2 0.000	D	25.2 0.000	+ 0.000 D/V
# 6 OR 11/7th Ave - Eastbound	E	44.1 0.000	E	44.1 0.000	+ 0.000 D/V
# 7 OR 11/7th Avenue - Westbound	C	18.9 0.000	C	18.9 0.000	+ 0.000 D/V
# 8 OR 11/ 4th Avenue	E	47.4 0.000	E	47.4 0.000	+ 0.000 D/V
# 9 Main Street/OR11/ 2nd Ave	C	21.1 0.316	C	21.1 0.316	+ 0.000 D/V

Kittelson & Associates, Inc. - Project #6743
Milton-Freewater STA and TSP Update - Milton-Freewater, OR
2025 Recommended Three-Lane Traffic Condition, Weekday AM Peak Hour

Level Of Service Computation Report
2000 HCM Unsignalized Method (Base Volume Alternative)

Intersection #1 OR 11/ 14th Ave

Average Delay (sec/veh): 6.5 Worst Case Level Of Service: D [31.9]

Table with 4 columns: North Bound, South Bound, East Bound, West Bound. Rows include Approach, Movement, Control, Rights, Lanes.

Volume Module: >> Count Date: 1 Dec 2004 <<. Table with 4 columns and 10 rows of traffic volume data.

Critical Gap Module: Table with 4 columns and 2 rows of critical gap and follow-up time data.

Capacity Module: Table with 4 columns and 4 rows of capacity and volume/capacity data.

Level Of Service Module: Table with 4 columns and 10 rows of queue, delay, and LOS data.

Kittelson & Associates, Inc. - Project #6743
Milton-Freewater STA and TSP Update - Milton-Freewater, OR
2025 Recommended Three-Lane Traffic Condition, Weekday AM Peak Hour

Level Of Service Computation Report
2000 HCM Unsignalized Method (Base Volume Alternative)

Intersection #2 Main Street-OR11/ 12th Ave

Average Delay (sec/veh): 7.1 Worst Case Level Of Services: F [152.9]

Table with 4 columns: North Bound, South Bound, East Bound, West Bound. Rows include Approach, Movement, Control, Rights, Lanes.

Volume Module: >> Count Date: 7 Dec 2004 <<. Table with 4 columns and 10 rows of traffic volume data.

Critical Gap Module: Table with 4 columns and 2 rows of critical gap and follow-up time data.

Capacity Module: Table with 4 columns and 4 rows of capacity and volume/capacity data.

Level Of Service Module: Table with 4 columns and 10 rows of queue, delay, and LOS data.

Kittelson & Associates, Inc. - Project #6743
Milton-Freewater STA and TSP Update - Milton-Freewater, OR
2025 Recommended Three-Lane Traffic Condition, Weekday AM Peak Hour

Level Of Service Computation Report
2000 HCM Unsignalized Method (Base Volume Alternative)

Intersection #3 Main Street - OR 11/ 10th Ave

Average Delay (sec/veh): 0.8 Worst Case Level Of Service: E [36.4]

Table with 4 columns: North Bound, South Bound, East Bound, West Bound. Rows include Movement, Control, Rights, Lanes.

Table with 4 columns: North Bound, South Bound, East Bound, West Bound. Rows include Volume Module, Base Vol, Growth Adj, Initial Bse, User Adj, PHF Adj, PHF Volume, Reduct Vol, Final Vol.

Table with 4 columns: North Bound, South Bound, East Bound, West Bound. Rows include Critical Gap Module, Critical Gp, FollowUpTim.

Table with 4 columns: North Bound, South Bound, East Bound, West Bound. Rows include Capacity Module, Conflict Vol, Potent Cap., Move Cap., Volume/Cap.

Table with 4 columns: North Bound, South Bound, East Bound, West Bound. Rows include Level Of Service Module, Queue, Stopped Del, LOS by Move, Movement, Shared Cap., Shared Queue, Shrd StpDel, Shared LOS, ApproachDel, ApproachLOS.

Kittelson & Associates, Inc. - Project #6743
Milton-Freewater STA and TSP Update - Milton-Freewater, OR
2025 Recommended Three-Lane Traffic Condition, Weekday AM Peak Hour

Level Of Service Computation Report
2000 HCM Unsignalized Method (Base Volume Alternative)

Intersection #4 Main Street - OR 11/ 9th Ave

Average Delay (sec/veh): 1.4 Worst Case Level Of Service: E [49.5]

Table with 4 columns: North Bound, South Bound, East Bound, West Bound. Rows include Movement, Control, Rights, Lanes.

Table with 4 columns: North Bound, South Bound, East Bound, West Bound. Rows include Volume Module, Base Vol, Growth Adj, Initial Bse, User Adj, PHF Adj, PHF Volume, Reduct Vol, Final Vol.

Table with 4 columns: North Bound, South Bound, East Bound, West Bound. Rows include Critical Gap Module, Critical Gp, FollowUpTim.

Table with 4 columns: North Bound, South Bound, East Bound, West Bound. Rows include Capacity Module, Conflict Vol, Potent Cap., Move Cap., Volume/Cap.

Table with 4 columns: North Bound, South Bound, East Bound, West Bound. Rows include Level Of Service Module, Queue, Stopped Del, LOS by Move, Movement, Shared Cap., Shared Queue, Shrd StpDel, Shared LOS, ApproachDel, ApproachLOS.

Kittelson & Associates, Inc. - Project #6743
Milton-Freewater STA and TSP Update - Milton-Freewater, OR
2025 Recommended Three-Lane Traffic Condition, Weekday AM Peak Hour

Level Of Service Computation Report
2000 HCM Unsignalized Method (Base Volume Alternative)

Intersection #5 Main Street-OR11/ 8th Ave

Average Delay (sec/veh): 1.2 Worst Case Level Of Service: D [25.2]

Table with columns for Approach (North, South, East, West Bound), Movement (L, T, R), Control (Uncontrolled, Stop Sign), Rights (Include), Lanes, Volume Module (Count, Date, Base Vol, Growth Adj, Initial Bse, User Adj, PHF Adj, PHF Volume, Reduct Vol, Final Vol), Critical Gap Module (Critical Gp, FollowUpTim), Capacity Module (Conflict Vol, Potent Cap, Move Cap, Total Cap, Volume/Cap), and Level Of Service Module (Queue, Stopped Del, LOS by Move, Movement, Shared Cap, Shared Queue, Shrd StpDel, Shared LOS, ApproachDel, ApproachLOS).

Kittelson & Associates, Inc. - Project #6743
Milton-Freewater STA and TSP Update - Milton-Freewater, OR
2025 Recommended Three-Lane Traffic Condition, Weekday AM Peak Hour

Level Of Service Computation Report
2000 HCM Unsignalized Method (Base Volume Alternative)

Intersection #6 OR 11/7th Ave - Eastbound

Average Delay (sec/veh): 0.4 Worst Case Level Of Service: E [44.1]

Table with columns for Approach (North, South, East, West Bound), Movement (L, T, R), Control (Uncontrolled, Stop Sign), Rights (Include), Lanes, Volume Module (Count, Date, Base Vol, Growth Adj, Initial Bse, User Adj, PHF Adj, PHF Volume, Reduct Vol, Final Vol), Critical Gap Module (Critical Gp, FollowUpTim), Capacity Module (Conflict Vol, Potent Cap, Move Cap, Total Cap, Volume/Cap), and Level Of Service Module (Queue, Stopped Del, LOS by Move, Movement, Shared Cap, Shared Queue, Shrd StpDel, Shared LOS, ApproachDel, ApproachLOS).

Kittelson & Associates, Inc. - Project #6743
Milton-Freewater STA and TSP Update - Milton-Freewater, OR
2025 Recommended Three-Lane Traffic Condition, Weekday AM Peak Hour

Level Of Service Computation Report
2000 HCM Unsignalized Method (Base Volume Alternative)

Intersection #7 OR 11/7th Avenue - Westbound

Average Delay (sec/veh): 0.4 Worst Case Level Of Service: C [18.9]

Table with 4 columns: North Bound, South Bound, East Bound, West Bound. Rows include Movement, Control, Rights, and Lanes.

Table with 4 columns: North Bound, South Bound, East Bound, West Bound. Rows include Volume Module, Base Vol, Growth Adj, Initial Bse, User Adj, PHF Adj, PHF Volume, Reduct Vol, and Final Vol.

Table with 4 columns: North Bound, South Bound, East Bound, West Bound. Rows include Critical Gap Module, Critical Gp, and FollowUpTim.

Table with 4 columns: North Bound, South Bound, East Bound, West Bound. Rows include Capacity Module, Conflict Vol, Potent Cap, Move Cap, and Volume/Cap.

Table with 4 columns: North Bound, South Bound, East Bound, West Bound. Rows include Level Of Service Module, Queue, Stopped Del, LOS by Move, Movement, Shared Cap, Shared Queue, Shrd StpDel, Shared LOS, ApproachDel, and ApproachLOS.

Kittelson & Associates, Inc. - Project #6743
Milton-Freewater STA and TSP Update - Milton-Freewater, OR
2025 Recommended Three-Lane Traffic Condition, Weekday AM Peak Hour

Level Of Service Computation Report
2000 HCM Unsignalized Method (Base Volume Alternative)

Intersection #8 OR 11/ 4th Avenue

Average Delay (sec/veh): 0.6 Worst Case Level Of Service: E [47.4]

Table with 4 columns: North Bound, South Bound, East Bound, West Bound. Rows include Movement, Control, Rights, and Lanes.

Table with 4 columns: North Bound, South Bound, East Bound, West Bound. Rows include Volume Module, Base Vol, Growth Adj, Initial Bse, User Adj, PHF Adj, PHF Volume, Reduct Vol, and Final Vol.

Table with 4 columns: North Bound, South Bound, East Bound, West Bound. Rows include Critical Gap Module, Critical Gp, and FollowUpTim.

Table with 4 columns: North Bound, South Bound, East Bound, West Bound. Rows include Capacity Module, Conflict Vol, Potent Cap, Move Cap, and Volume/Cap.

Table with 4 columns: North Bound, South Bound, East Bound, West Bound. Rows include Level Of Service Module, Queue, Stopped Del, LOS by Move, Movement, Shared Cap, Shared Queue, Shrd StpDel, Shared LOS, ApproachDel, and ApproachLOS.

Kittelston & Associates, Inc. - Project #6743
Milton-Freewater STA and TSP Update - Milton-Freewater, OR
2025 Recommended Three-Lane Traffic Condition, Weekday AM Peak Hour

Level Of Service Computation Report
2000 HCM Operations Method (Base Volume Alternative)

Intersection #9 Main Street/OR11/ 2nd Ave

Cycle (sec): 100 Critical Vol./Cap. (X): 0.316
Loss Time (sec): 12 (Y+R = 4 sec) Average Delay (sec/veh): 21.1
Optimal Cycle: 32 Level Of Service: C

Approach:	North Bound			South Bound			East Bound			West Bound		
Movement:	L	T	R	L	T	R	L	T	R	L	T	R
Control:	Permitted			Permitted			Split Phase			Split Phase		
Rights:	Ignore			Include			Include			Include		
Min. Green:	0	0	0	0	0	0	0	0	0	0	0	0
Lanes:	0	1	1	0	0	1	0	0	1	1	0	1

Volume Module:	>>	Count	Date:	30 Nov 2004	<<													
Base Vol:	14	170	407	0	159	1	7	0	11	262	19	1						
Growth Adj:	1.32	1.61	1.61	1.32	1.61	1.32	1.32	1.32	1.32	1.61	1.32	1.32						
Initial Bse:	18	274	655	0	256	1	9	0	15	422	25	1						
User Adj:	1.00	1.00	0.00	1.00	1.00	1.00	1.00	1.00	1.00	1.00	1.00	1.00						
PHF Adj:	0.90	0.90	0.00	0.90	0.90	0.90	0.90	0.90	0.90	0.90	0.90	0.90						
PHF Volume:	21	304	0	0	285	1	10	0	16	469	28	1						
Reduct Vol:	0	0	0	0	0	0	0	0	0	0	0	0						
Reduced Vol:	21	304	0	0	285	1	10	0	16	469	28	1						
PCE Adj:	1.00	1.00	0.00	1.00	1.00	1.00	1.00	1.00	1.00	1.00	1.00	1.00						
MUF Adj:	1.00	1.00	0.00	1.00	1.00	1.00	1.00	1.00	1.00	1.00	1.00	1.00						
Final Vol.:	21	304	0	0	285	1	10	0	16	469	28	1						

Saturation Flow Module:												
Sat/Lane:	1800	1800	1800	1800	1800	1800	1800	1800	1800	1800	1800	1800
Adjustment:	0.86	0.86	1.00	1.00	0.93	0.93	0.88	1.00	0.88	0.94	0.94	0.94
Lanes:	0.13	1.87	1.00	0.00	1.99	0.01	0.39	0.00	0.61	1.89	0.10	0.01
Final Sat.:	196	2898	1800	0	3331	17	618	0	971	3182	178	9

Capacity Analysis Module:												
Vol/Sat:	0.10	0.10	0.00	0.00	0.09	0.09	0.02	0.00	0.02	0.15	0.16	0.16
Crit. Moves:	****			****			****			****		
Green/Cycle:	0.33	0.33	0.00	0.00	0.33	0.33	0.05	0.00	0.05	0.50	0.50	0.50
Volume/Cap:	0.32	0.32	0.00	0.00	0.26	0.26	0.32	0.00	0.32	0.30	0.32	0.32
Delay/Veh:	25.1	25.1	0.0	0.0	24.5	24.5	47.8	0.0	47.8	15.0	15.2	15.2
User DelAdj:	1.00	1.00	1.00	1.00	1.00	1.00	1.00	1.00	1.00	1.00	1.00	1.00
AdjDel/Veh:	25.1	25.1	0.0	0.0	24.5	24.5	47.8	0.0	47.8	15.0	15.2	15.2
HCM2kAvg:	4	4	0	0	3	3	1	0	1	5	5	5

Traffic 7.7.1115 (c) 2004 Dowling Assoc. Licensed to KITTELSON, PORTLAND

Kittelson & Associates, Inc. Project # 6743
 Milton-Freewater STP and TSP Update Plan, Milton-Freewater, OR
 2025 Recommended Three-Lane Traffic Condition, Weekday PM Peak Hour

Scenario: PM-3Lane-Reco Scenario Report
 Command: PM-3Lane-Reco
 Volume: PM
 Geometry: 3-lane-Reco
 Impact Fee: Default Impact Fee
 Trip Generation: Default Trip Generation
 Trip Distribution: Default Trip Distribution
 Paths: Default Paths
 Routes: Default Routes
 Configuration: Default Configuration

Kittelson & Associates, Inc. Project # 6743
 Milton-Freewater STP and TSP Update Plan, Milton-Freewater, OR
 2025 Recommended Three-Lane Traffic Condition, Weekday PM Peak Hour

Impact Analysis Report
 Level Of Service

Intersection	Base		Future		Change in
	LOS	Veh / C	LOS	Veh / C	
# 1 OR 11/ 14th Ave	D	29.7 0.000	D	29.7 0.000	+ 0.000 D/V
# 2 Main Street-OR11/ 12th Ave	F	150.4 0.000	F	150.4 0.000	+ 0.000 D/V
# 3 Main Street - OR 11/ 10th Ave	F	237.8 0.000	F	237.8 0.000	+ 0.000 D/V
# 4 Main Street - OR 11/ 9th Ave	F	86.8 0.000	F	86.8 0.000	+ 0.000 D/V
# 5 Main Street-OR11/ 8th Ave	E	45.4 0.000	E	45.4 0.000	+ 0.000 D/V
# 6 OR 11/7th Ave - Eastbound	F	102.4 0.000	F	102.4 0.000	+ 0.000 D/V
# 7 OR 11/7th Avenue - Westbound	C	15.4 0.000	C	15.4 0.000	+ 0.000 D/V
# 8 OR 11/ 4th Avenue	F	74.5 0.000	F	74.5 0.000	+ 0.000 D/V
# 9 Main Street/OR11/ 2nd Ave	C	20.6 0.456	C	20.6 0.456	+ 0.000 D/V

Kittelson & Associates, Inc. Project # 6743
Milton-Freewater STP and TSP Update Plan, Milton-Freewater, OR
2025 Recommended Three-Lane Traffic Condition, Weekday PM Peak Hour

Level Of Service Computation Report
2000 HCM Unsignalized Method (Base Volume Alternative)

Intersection #1 OR 11/ 14th Ave

Average Delay (sec/veh): 5.4 Worst Case Level Of Service: D [29.7]

Table with 4 columns: North Bound, South Bound, East Bound, West Bound. Rows include Approach, Movement, Control, Rights, Lanes.

Volume Module: >> Count Date: 1 Dec 2004 <<. Table with 4 columns for movement types. Rows include Base Vol, Growth Adj, Initial Bse, User Adj, PHF Adj, PHF Volume, Reduct Vol, Final Vol.

Critical Gap Module: Critical Gp:xxxx xxx xxxxx. Table with 4 columns for movement types. Rows include Critical Gp, FollowUpTim.

Capacity Module: Cnflct Vol:xxxx xxx xxxxx. Table with 4 columns for movement types. Rows include Cnflct Vol, Potent Cap., Move Cap., Volume/Cap.

Level Of Service Module: Queue:xxxx xxx xxxxx. Table with 4 columns for movement types. Rows include Queue, Stopped Del, LOS by Move, Movement, Shared Cap., Shared Queue, Shrd StpDel, Shared LOS, ApproachDel, ApproachLOS.

Kittelson & Associates, Inc. Project # 6743
Milton-Freewater STP and TSP Update Plan, Milton-Freewater, OR
2025 Recommended Three-Lane Traffic Condition, Weekday PM Peak Hour

Level Of Service Computation Report
2000 HCM Unsignalized Method (Base Volume Alternative)

Intersection #2 Main Street-OR11/ 12th Ave

Average Delay (sec/veh): 3.4 Worst Case Level Of Service: F [150.4]

Table with 4 columns: North Bound, South Bound, East Bound, West Bound. Rows include Approach, Movement, Control, Rights, Lanes.

Volume Module: >> Count Date: 7 Dec 2004 <<. Table with 4 columns for movement types. Rows include Base Vol, Growth Adj, Initial Bse, User Adj, PHF Adj, PHF Volume, Reduct Vol, Final Vol.

Critical Gap Module: Critical Gp:xxxx xxxxx. Table with 4 columns for movement types. Rows include Critical Gp, FollowUpTim.

Capacity Module: Cnflct Vol:905 xxx xxxxx. Table with 4 columns for movement types. Rows include Cnflct Vol, Potent Cap., Move Cap., Volume/Cap.

Level Of Service Module: Queue:0.0 xxx xxxxx. Table with 4 columns for movement types. Rows include Queue, Stopped Del, LOS by Move, Movement, Shared Cap., Shared Queue, Shrd StpDel, Shared LOS, ApproachDel, ApproachLOS.

Kittelson & Associates, Inc. Project # 6743
Milton-Freewater STP and TSP Update Plan, Milton-Freewater, OR
2025 Recommended Three-Lane Traffic Condition, Weekday PM Peak Hour

Level Of Service Computation Report
2000 HCM Unsignalized Method (Base Volume Alternative)

Intersection #3 Main Street - OR 11/ 10th Ave

Average Delay (sec/veh): 5.8 Worst Case Level Of Service: F[237.8]

Table with 4 columns: Approach: North Bound, South Bound, East Bound, West Bound. Rows include Movement, Control, Rights, and Lanes.

Table with 4 columns: Volume Module, Growth Adj, Initial Bse, User Adj, PHF Adj, PHF Volume, Reduct Vol, Final Vol.

Table with 4 columns: Critical Gap Module, Critical Gp, FollowUpTim.

Table with 4 columns: Capacity Module, Conflict Vol, Potent Cap., Move Cap., Volume/Cap.

Table with 4 columns: Level Of Service Module, Queue, Stopped Del, LOS by Move, Movement, Shared Cap., Shared Queue, Shrd StpDel, Shared LOS, ApproachDel, ApproachLOS.

Kittelson & Associates, Inc. Project # 6743
Milton-Freewater STP and TSP Update Plan, Milton-Freewater, OR
2025 Recommended Three-Lane Traffic Condition, Weekday PM Peak Hour

Level Of Service Computation Report
2000 HCM Unsignalized Method (Base Volume Alternative)

Intersection #4 Main Street - OR 11/ 9th Ave

Average Delay (sec/veh): 2.2 Worst Case Level Of Service: F[86.8]

Table with 4 columns: Approach: North Bound, South Bound, East Bound, West Bound. Rows include Movement, Control, Rights, and Lanes.

Table with 4 columns: Volume Module, Growth Adj, Initial Bse, User Adj, PHF Adj, PHF Volume, Reduct Vol, Final Vol.

Table with 4 columns: Critical Gap Module, Critical Gp, FollowUpTim.

Table with 4 columns: Capacity Module, Conflict Vol, Potent Cap., Move Cap., Volume/Cap.

Table with 4 columns: Level Of Service Module, Queue, Stopped Del, LOS by Move, Movement, Shared Cap., Shared Queue, Shrd StpDel, Shared LOS, ApproachDel, ApproachLOS.

Kittelson & Associates, Inc. Project # 6743
Milton-Freewater STP and TSP Update Plan, Milton-Freewater, OR
2025 Recommended Three-Lane Traffic Condition, Weekday PM Peak Hour

Level Of Service Computation Report
2000 HCM Unsignalized Method (Base Volume Alternative)

Intersection #5 Main Street-OR117 Bth Ave

Average Delay (sec/veh): 1.3 Worst Case Level Of Service: E[45.4]

Table with 4 columns: North Bound, South Bound, East Bound, West Bound. Rows include Approach, Movement, Control, Rights, Lanes.

Table with 4 columns: North Bound, South Bound, East Bound, West Bound. Rows include Volume Module, Base Vol, Growth Adj, Initial Bse, User Adj, PHF Adj, PHF Volume, Reduct Vol, Final Vol.

Table with 4 columns: North Bound, South Bound, East Bound, West Bound. Rows include Critical Gap Module, Critical Gp, FollowUpTim.

Table with 4 columns: North Bound, South Bound, East Bound, West Bound. Rows include Capacity Module, Cnflct Vol, Potent Cap., Move Cap., Total Cap, Volume/Cap.

Table with 4 columns: North Bound, South Bound, East Bound, West Bound. Rows include Level Of Service Module, Queue, Stopped Del, LOS by Move, Movement, Shared Cap., Shared Queue, Shrd StpDel, Shared LOS, ApproachDel, ApproachLOS.

Kittelson & Associates, Inc. Project # 6743
Milton-Freewater STP and TSP Update Plan, Milton-Freewater, OR
2025 Recommended Three-Lane Traffic Condition, Weekday PM Peak Hour

Level Of Service Computation Report
2000 HCM Unsignalized Method (Base Volume Alternative)

Intersection #6 OR 117th Ave - Eastbound

Average Delay (sec/veh): 2.7 Worst Case Level Of Service: F[102.4]

Table with 4 columns: North Bound, South Bound, East Bound, West Bound. Rows include Approach, Movement, Control, Rights, Lanes.

Table with 4 columns: North Bound, South Bound, East Bound, West Bound. Rows include Volume Module, Base Vol, Growth Adj, Initial Bse, User Adj, PHF Adj, PHF Volume, Reduct Vol, Final Vol.

Table with 4 columns: North Bound, South Bound, East Bound, West Bound. Rows include Critical Gap Module, Critical Gp, FollowUpTim.

Table with 4 columns: North Bound, South Bound, East Bound, West Bound. Rows include Capacity Module, Cnflct Vol, Potent Cap., Move Cap., Total Cap, Volume/Cap.

Table with 4 columns: North Bound, South Bound, East Bound, West Bound. Rows include Level Of Service Module, Queue, Stopped Del, LOS by Move, Movement, Shared Cap., Shared Queue, Shrd StpDel, Shared LOS, ApproachDel, ApproachLOS.

Kittelson & Associates, Inc. Project # 6743
Milton-Freewater STP and TSP Update Plan, Milton-Freewater, OR
2025 Recommended Three-Lane Traffic Condition, Weekday PM Peak Hour

Level Of Service Computation Report
2000 HCM Unsignalized Method (Base Volume Alternative)

Intersection #7 OR 11/7th Avenue - Westbound

Average Delay (sec/veh): 0.2 Worst Case Level Of Service: CI 15.4]

Table with 4 columns: Approach: North Bound, South Bound, East Bound, West Bound. Rows include Movement, Control, Rights, Lanes, Volume Module, Critical Gap Module, Capacity Module, and Level Of Service Module.

Volume Module table showing Base Vol, Growth Adj, Initial Bse, User Adj, PHF Adj, PHF Volume, Reduct Vol, and Final Vol for each approach.

Critical Gap Module table showing Critical Gp and FollowUpTim for each approach.

Capacity Module table showing Conflict Vol, Potent Cap., Move Cap., and Volume/Cap for each approach.

Level Of Service Module table showing Queue, Stopped Del, LOS by Move, Movement, Shared Cap., Shared Queue, Shrd StpDel, Shared LOS, ApproachDel, and ApproachLOS for each approach.

Kittelson & Associates, Inc. Project # 6743
Milton-Freewater STP and TSP Update Plan, Milton-Freewater, OR
2025 Recommended Three-Lane Traffic Condition, Weekday PM Peak Hour

Level Of Service Computation Report
2000 HCM Unsignalized Method (Base Volume Alternative)

Intersection #8 OR 11/4th Avenue

Average Delay (sec/veh): 0.6 Worst Case Level Of Service: F [74.5]

Table with 4 columns: Approach: North Bound, South Bound, East Bound, West Bound. Rows include Movement, Control, Rights, Lanes, Volume Module, Critical Gap Module, Capacity Module, and Level Of Service Module.

Volume Module table showing Base Vol, Growth Adj, Initial Bse, User Adj, PHF Adj, PHF Volume, Reduct Vol, and Final Vol for each approach.

Critical Gap Module table showing Critical Gp and FollowUpTim for each approach.

Capacity Module table showing Conflict Vol, Potent Cap., Move Cap., and Volume/Cap for each approach.

Level Of Service Module table showing Queue, Stopped Del, LOS by Move, Movement, Shared Cap., Shared Queue, Shrd StpDel, Shared LOS, ApproachDel, and ApproachLOS for each approach.

Kittelson & Associates, Inc. Project # 6743
Milton-Freewater STP and TSP Update Plan, Milton-Freewater, OR
2025 Recommended Three-Lane Traffic Condition, Weekday PM Peak Hour

Level Of Service Computation Report
2000 HCM Operations Method (Base Volume Alternative)

Intersection #9 Main Street/OR11/ 2nd Ave

Cycle (sec): 100 Critical Vol./Cap. (X): 0.456
Loss Time (sec): 12 (Y+R = 4 sec) Average Delay (sec/veh): 20.6
Optimal Cycle: 38 Level Of Service: C

Table with 4 columns: North Bound, South Bound, East Bound, West Bound. Rows include Movement, Control, Rights, Min. Green, and Lanes.

Volume Module: >> Count Date: 30 Nov 2004 <<
Table with 12 columns and 10 rows: Base Vol, Growth Adj, Initial Bse, User Adj, PHF Adj, PHF Volume, Reduct Vol, Reduced Vol, PCE Adj, MLF Adj, Final Vol.

Saturation Flow Module:
Table with 12 columns and 4 rows: Sat/Lane, Adjustment, Lanes, Final Sat.

Capacity Analysis Module:
Table with 12 columns and 10 rows: Vol/Sat, Crit Moves, Green/Cycle, Volume/Cap, Delay/Veh, User DelAdj, Adj Del/Veh, HCM2kAvg.

Traffix 7.7.1115 (c) 2004 Dowling Assoc. Licensed to KITTELSON, PORTLAND

Appendix I

Queuing Analysis Results

Project Name: Milton-Freewater STA and TSP update
 Project #: 6743
 Analysis Scenario: Existing Conditions
 Analysis Period: 0.25 (peak 15 minute analysis)
 Analyst: JRP
 Date: June 2, 2005

V = flow rate for movement
 C = capacity of movement
 Q = 95th percentile queue (veh)
 S = storage need (ft)

of Int: 8
 Veh. Length (ft): 25

* Queue length calculated using Equation (17-37) presented in Highway Capacity Manual 200

		EB Shared	WB Shared	WB RT	WB LT
ORE 11/ SW 14th Ave.	C			189	11
	Q			529	158
	S			1.6	0.2
ORE 11/ SW 12th Ave.	C	25	17		
	Q	161	344		
	S	0.5	0.2		
ORE 11/ SW 10th Ave.	C	32	30		
	Q	159	317		
	S	0.7	0.3		
ORE 11/ SW 9th Ave.	C	17	22		
	Q	200	266		
	S	0.3	0.3		
ORE 11/ SW 8th Ave.	C	41	6		
	Q	137	140		
	S	1.2	0.1		
ORE 11/ SW 7th Ave.	C	50	25		
	Q	42			
	S	218			
ORE 11/ SW 4th Ave.	C	0.7			
	Q	25			
	S	7	22		
ORE 11/ SW 4th Ave.	C	169	486		
	Q	0.1	0.1		
	S	25	25		

Project Name: Milton-Freewater STA and TSP update
 Project #: 6743
 Analysis Scenario: 2004 Conditions - Three Lanes
 Analysis Period: 0.25 (peak 15 minute analysis)
 Analyst: TRP
 Date: June 2, 2005

V = flow rate for movement
 C = capacity of movement
 Q = 95th percentile queue (veh)
 S = storage need (ft)

of Int: 8
 Veh. Length (ft): 25

* Queue length calculated using Equation (17-37) presented in Highway Capacity Manual 2000

		EB Shared	WB Shared	WB RT	WB LT
ORE 11/ SW 14th Ave.	C			189	11
	Q			533	110
	S			1.6	0.3
ORE 11/ SW 12th Ave.	C	25	17		
	Q	116	268		
	S	0.8	0.2		
ORE 11/ SW 10th Ave.	C	25	25		
	Q	32	30		
	S	106	223		
ORE 11/ SW 9th Ave.	C	1.2	0.5		
	Q	50	25		
	S	17	22		
ORE 11/ SW 8th Ave.	C	138	182		
	Q	0.4	0.4		
	S	25	25		
ORE 11/ SW 7th Ave.	C	41	6		
	Q	92	93		
	S	1.9	0.2		
ORE 11/ SW 4th Ave.	C	50	25		
	Q	42			
	S	164			
ORE 11/ SW 4th Ave.	C	1.0			
	Q	25			
	S	7	22		
ORE 11/ SW 4th Ave.	C	119	352		
	Q	0.2	0.2		
	S	25	25		

Project Name: Milton-Freewater STA and TSP update
 Project #: 6743
 Analysis Scenario: 2025 Conditions - Four Lanes
 Analysis Period: 0.25 (peak 15 minute analysis)
 Analyst: JRP
 Date: June 2, 2005

V = flow rate for movement
 C = capacity of movement
 Q = 95th percentile queue (veh)
 S = storage need (ft)

of Int: 8
 Veh. Length (ft): 25

* Queue length calculated using Equation (17-37) presented in *Highway Capacity Manual 2000*

		EB Shared	WB Shared	WB RT	WB LT
ORE 11/ SW 14th Ave.	C			249	15
	Q			419	78
	S			3.7	0.7
ORE 11/ SW 12th Ave.	C	35	23		
	Q	84	209		
	S	1.7	0.4		
ORE 11/ SW 10th Ave.	C	50	25		
	Q	41	39		
	S	81	188		
ORE 11/ SW 9th Ave.	C	2.2	0.8		
	Q	75	25		
	S	21	29		
ORE 11/ SW 8th Ave.	C	108	153		
	Q	0.7	0.7		
	S	25	25		
ORE 11/ SW 7th Ave.	C	54	9		
	Q	67	66		
	S	3.8	0.4		
ORE 11/ SW 4th Ave.	C	100	25		
	Q	58			
	S	129			
ORE 11/ SW 4th Ave.	C	2.0			
	Q	50			
	S	10	30		
ORE 11/ SW 4th Ave.	C	90	341		
	Q	0.4	0.3		
	S	25	25		

Project Name: Milton-Freewater STA and TSP update
 Project #: 6743
 Analysis Scenario: 2025 Conditions - Three Lanes
 Analysis Period: 0.25 (peak 15 minute analysis)
 Analyst: JRP
 Date: June 2, 2005

V = flow rate for movement
 C = capacity of movement
 Q = 95th percentile queue (veh)
 S = storage need (ft)

of Int: 7
 Veh. Length (ft): 25

* Queue length calculated using Equation (17-37) presented in Highway Capacity Manual 200

		EB Shared	WB Shared	WB RT	WB LT
ORE 11/ SW 14th Ave.	C			249	15
	Q			422	49
	S			3.7	1.1
ORE 11/ SW 12th Ave.	C	35	23		
	Q	54	152		
	S	2.6	0.5		
ORE 11/ SW 10th Ave.	C	41	39		
	Q	46	117		
	S	3.6	1.3		
ORE 11/ SW 9th Ave.	C	21	29		
	Q	65	91		
	S	1.2	1.2		
ORE 11/ SW 8th Ave.	C	54	9		
	Q	141	144		
	S	1.6	0.2		
ORE 11/ SW 7th Ave.	C	58			
	Q	87			
	S	3.2			
ORE 11/ SW 4th Ave.	C	10	30		
	Q	61	266		
	S	0.5	0.4		

SIGNALIZED QUEUE ANALYSIS

Project Name: Milton-Freewater STA and TSP update
Project Number: 6743
Analyst: JPP
Date: 6/2/2005
Filename: H:\proj\6743\excel\Sig Queue2025Four.xls\SIGQUEUE



KITTELSON & ASSOCIATES, INC.
 610 SW Alder, Suite 700
 Portland, Oregon 97205
 (503) 228-5230
 Fax: (503) 273-8169

Intersection: ORE 117 SW 2nd Ave
Conditions (yr, alt., etc.): 2004 Four Lane

GENERAL INPUT PARAMETERS:

Cycle Length:	100 sec
Confidence Level (C.L.):	95%
Storage length/vehicle:	25 feet

	APPROACH/MOVEMENT							
	#1	#2	#3	#4	#5	#6	#7	#8
	NBLT	NBTH/LT	SBLT	SBTH/RT	EBLT	EB-Shared	WB-Shared	
INPUT PARAMETERS:								
Volume (pre-PHF) (vph):		256		264		15	679	
G/C for movement:		0.24		0.24		0.02	0.62	
Number of lanes:		2		2		1	2	
CALCULATIONS:								
Length of red interval (sec):		76.0		76.0		98.0	38.0	
Average total queue (veh):		5.4		5.6		0.4	7.2	
Maximum total queue (veh):		9		10		2	12	
Total queue length (feet):		225		250		50	300	
Required storage/lane (feet):		125		125		50	150	
PERMITTED LEFT TURNS:								
Opposing volume (pre-PHF):								
Opposing sat. flow rate:								
CALCULATIONS:								
Opposing flow ratio (Yo):								
Unblocked G/C:								
Effective red interval (sec):								
Average total queue (veh):								
Maximum total queue (veh):								
Total queue length (feet):								
Required storage/lane (feet):								

METHODOLOGY AND FORMULAS USED:

Length of red interval = $(1 - G/C) \cdot \text{Cycle length}$

Queue length = Maximum Queue * Storage length per vehicle

Average queue/lane = Volume * Red Interval / 3600

Required Storage per lane = Queue length / Number of lanes, rounded up to the next highest whole vehicle

Maximum queue: Random arrival/Constant service

Random arrivals behave according to a Poisson distribution.

There is a probability equal to the confidence level desired (e.g. 95%)

that the queue formed during each red interval will be less than or equal to the maximum queue

Opposing flow ratio Yo = opposing volume v0 / opposing sat. flow rate s0

Unblocked G/C (gu/C) = $(g/C - Yo)(1 - Yo)$

(Prob. of arrival = N) = $(\text{Red Interval})^N \cdot \exp(-M) / N!$ (the Poisson distribution)

(Prob. of arrival = N) = $1 - \text{Sum of probabilities for vehicles 0, 1, ..., N-1}$

Max N = Highest N such that the sum of probabilities is $(1 - \text{confidence level})$

SIGNALIZED QUEUE ANALYSIS

Project Name: Milroy Freeway STA and TSP Update
Project Number: 6743
Analyst: JFE
Date: 6/2/2005
Filename: H:\projects\743\excel\Sig_Queue_2005\Four_Lane_Sig_Queue

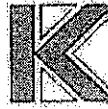

KITTELSON & ASSOCIATES, INC.
 610 SW Alder, Suite 700
 Portland, Oregon 97205
 (503) 228-5230
 Fax: (503) 273-8169

Intersection: ORE 11 / SW 2nd Ave
Conditions (yr, alt., etc.): 2004 Three Lane

GENERAL INPUT PARAMETERS:

Cycle Length:	100 sec
Confidance Level (C.L.):	95%
Storage length/vehicle:	25 feet

	APPROACH/MOVEMENT							
	#1	#2	#3	#4	#5	#6	#7	#8
	NBLT	NBTHLT	SBLT	SBTHRT	EBLT	EB Shared	WB Shared	WBRT
INPUT PARAMETERS:								
Volume (pre-PHF) (vph):		256		264		15	679	
G/C for movement:		0.24		0.24		0.02	0.62	
Number of lanes:		1		1		1	2	
CALCULATIONS:								
Length of red interval (sec):		76.0		76.0		98.0	38.0	
Average total queue (veh):		5.4		5.6		0.4	7.2	
Maximum total queue (veh):		9		10		2	12	
Total queue length (feet):		225		250		50	300	
Required storage/lane (feet):		225		250		50	150	
PERMITTED LEFT TURNS:								
Opposing volume (pre-PHF):								
Opposing sat. flow rate:								
CALCULATIONS:								
Opposing flow ratio (Yo):								
Unblocked G/C:								
Effective red interval (sec):								
Average total queue (veh):								
Maximum total queue (veh):								
Total queue length (feet):								
Required storage/lane (feet):								

METHODOLOGY AND FORMULAS USED:

Length of red interval = $(1 - G/C) \cdot \text{Cycle length}$

Average queue length = $\text{Volume} \cdot \text{Red interval} / 3600$

Maximum queue: Random arrival/Constant service

Random arrivals behave according to a Poisson distribution.

There is a probability equal to the confidence level desired (e.g. 95%)

that the queue formed during each red interval will be less than

or equal to the maximum queue.

If the # of arrivals = N = (Red interval) / N = exp $(\lambda \cdot R) / R!$ (the Poisson distribution)

If the # of arrivals = N = 1 - Sum of probabilities for vehicles 0, 1, ..., N-1

Make N highest N such that the sum of probabilities > (1 - confidence level)

Queue length = Maximum queue * Storage length per vehicle

Required storage per lane = Queue length / Number of lanes, rounded up to the next highest whole vehicle.

Opposing flow ratio Y_o = opposing volume v_o / opposing sat. flow rate s_o

Unblocked G/C g_u = $G/C - Y_o / (1 - Y_o)$

SIGNALIZED QUEUE ANALYSIS

Project Name: Milton-Freewater STA and TSP Update
Project Number: 6743
Analyst: JRP
Date: 6/2/2005
Filename: H:\proj\6743\proj\Sig Queue\2025\Four.lane\SIGQUEUE



KITTELSON & ASSOCIATES, INC.
 610 SW Alder, Suite 700
 Portland, Oregon 97205
 (503) 228-5230
 Fax: (503) 273-8169

Intersection: ORE 17 / SW 2nd Ave
Conditions (yr, alt., etc.): 2025 Four-lane

GENERAL INPUT PARAMETERS:

Cycle Length:	100 sec
Confidence Level (C.L.):	95%
Storage length/vehicle:	25 feet

	APPROACH/MOVEMENT							
	#1	#2	#3	#4	#5	#6	#7	#8
	NBLT	NBTH/RT	SBLT	SBTH/RT	EBCT	EB Shared	WB Shared	WBTH/RT
INPUT PARAMETERS:								
Volume (pre-PHF) (vph):		337		348		20	395	
G/C for movement:		0.24		0.24		0.02	0.62	
Number of lanes:		2		2		1	2	
CALCULATIONS:								
Length of red interval (sec):		76.0		76.0		98.0	38.0	
Average total queue (veh):		7.1		7.3		0.5	9.4	
Maximum total queue (veh):		12		12		2	15	
Total queue length (feet):		300		300		50	375	
Required storage/lane (feet):		150		150		50	200	
PERMITTED LEFT TURNS:								
Opposing volume (pre-PHF):								
Opposing sat. flow rate:								
CALCULATIONS:								
Opposing flow ratio (Yo):								
Unblocked G/C:								
Effective red interval (sec):								
Average total queue (veh):								
Maximum total queue (veh):								
Total queue length (feet):								
Required storage/lane (feet):								

METHODOLOGY AND FORMULAS USED:

Length of red interval = $(1 - G/C) \cdot \text{Cycle length}$

Queue length = Maximum queue * Storage length per vehicle

Average queue length = Volume * Red interval / 3600

Required storage per lane = Queue length / Number of lanes, rounded up to the next highest whole vehicle

Maximum queue: Random arrival/Constant service

Random arrivals between according to a Poisson distribution

There is a probability equal to the confidence level desired (e.g. 95%)

that the queue length during each red interval will be less than

to equal to the maximum queue

Opposing flow ratio Yo = opposing volume / opposing sat. flow rate

Unblocked G/C (guC) = $(g/C - Yo)/(1 - Yo)$

(Prob. of arrival = N) = $(\text{Red interval} / \text{cycle length}) \cdot N!$ (the Poisson distribution)

(Prob. of arrival = N) = $1 - \text{sum of probabilities for vehicles } 0, 1, \dots, N-1$

Max N: Highest N such that the sum of probabilities > $(1 - \text{confidence level})$

SIGNALIZED QUEUE ANALYSIS

Project Name: Milon-Freewater STA and TSP Update
Project Number: 6743
Analyst: JPP
Date: 6/2/2005
Filename: H:\projfile\6743\excel\Sig Queue2025Four.xls\SIGQUEUE



KITTELSON & ASSOCIATES, INC.
 610 SW Alder, Suite 700
 Portland, Oregon 97205
 (503) 228-5230
 Fax: (503) 273-8169

Intersection: ORE 17 SW 2nd Ave
Conditions (yr, alt., etc.): 2025 Three-lane

GENERAL INPUT PARAMETERS:

Cycle Length:	100 sec
Confidence Level (C.L.):	95%
Storage length/vehicle:	25 feet

	APPROACH/MOVEMENT							
	#1 NBLT	#2 NBTHLT	#3 SBLT	#4 SBTHLT	#5 EBLT	#6 EB-Shared	#7 WBLT	#8 WBTHLT
INPUT PARAMETERS:								
Volume (pre-PHF) (vph):		337		346		20		595
G/C for movement:		0.24		0.24		0.02		0.62
Number of lanes:						1		2
CALCULATIONS:								
Length of red interval (sec):		76.0		76.0		98.0		38.0
Average total queue (veh):		7.1		7.3		0.5		9.4
Maximum total queue (veh):		12		12		2		15
Total queue length (feet):		300		300		50		375
Required storage/lane (feet):		300		300		50		200
PERMITTED LEFT TURNS:								
Opposing volume (pre-PHF):								
Opposing sat. flow rate:								
CALCULATIONS:								
Opposing flow ratio (Yo):								
Unblocked G/C:								
Effective red interval (sec):								
Average total queue (veh):								
Maximum total queue (veh):								
Total queue length (feet):								
Required storage/lane (feet):								

METHODOLOGY AND FORMULAS USED:

Length of red interval = (1 - G/C) * Cycle length

Average queue/lane = Volume * Red interval / 3600

Maximum queue: Random arrival/Constant service

Random arrivals follow according to a Poisson distribution.

There is a probability equal to the confidence level desired (e.g. 95%)

that the queue formed during each red interval will be less than

or equal to the maximum queue.

Prob. of arrival in N = (Red interval)^N * exp(-N) / N! (the Poisson distribution)

Prob. of arrival in N = 1 - Sum of probabilities for vehicles 0, 1, ..., N-1

Max N: Highest N such that the sum of probabilities >= (1 - Confidence level)

Queue length = Maximum queue * Storage length per vehicle

Required storage per lane = Queue length / Number of lanes, rounded up to the next highest whole vehicle

Opposing flow ratio Yo = opposing volume vo / opposing sat. flow rate sop

Unblocked G/C (gu/C) = (g/C - Yo)/(1 - Yo)

M e m o r a n d u m



17355 SW Boones Ferry Rd
Lake Oswego, OR 97035
Phone (503) 635-3618
Fax (503) 635-5395

To: Milton Freewater Client
From: Kay Van Sickel, Kate Schwarzler
Copies: Milton-Freewater TAC
Date: June 6, 2005
Subject: Funding Memorandum
Project #: 12679

Funding Options

The Milton-Freewater streetscape improvement project can be funded by a variety of sources, including urban renewal funds and Community Development Block Grant (CBDG) grants and other federal and state program which are identified in this memo. Federal funds for transportation and infrastructure improvements are derived through the Economic Development Administration (EDA), the Housing and Urban Development Administration (HUD), and through the US Department of Transportation, Federal Transportation Administration (FTA). Access to federal grants is typically obtained through county or state governmental bodies, such As the Oregon Economic Development Department and Oregon Department of Transportation.

State funding, financing, and technical assistance are provided through Oregon Economic Development (OEDD), Oregon Department of Transportation (ODOT) and other programs. The following matrix provides a comprehensive list of funding "possibilities" available for consideration on the streetscape project.

Funding Source / Contact	Program Description
--------------------------	---------------------

Grants

<p>Transportation Enhancement Program</p> <p>Contact: Pat Rogers Fisher 503-986-3528</p>	<p>The Transportation Enhancement program provides federal highway funds for projects that strengthen the cultural, aesthetic, or environmental value of our transportation system. The funds are available for twelve "transportation enhancement activities" specifically identified in the Transportation Equity Act for the 21st Century (TEA-21). These activities fall into four main groups:</p> <ul style="list-style-type: none"> • Pedestrian and Bicycle Projects • Historic Preservation related to surface transportation • Landscaping and Scenic Beautification • Environmental Mitigation (highway runoff and wildlife protection only) <p>The intent of the program is to fund special or additional activities not normally required on a highway or transportation project. So far, Oregon has funded more than 150 projects for a total of \$63 million.</p> <p>Transportation Enhancement or "TE" projects are selected through a competitive process. The funds are provided through reimbursement, not grants. Participation requires matching funds from the project sponsor, at a minimum of 10.27%. Applications are accepted only from public agencies. Private organizations may apply in partnership with a local, state or federal agency, or Indian tribe. All projects must have a direct relationship to surface transportation. (\$ of grant awards: vary)</p>
	<p>www.odot.state.or.us/techserv/engineer/pdu/enhancement/program%20information/enhanceoct02.htm</p>
<p>Pedestrian and Bicycle Improvement Grant Program</p> <p>Contact: Michael Ronkin, (503) 986-3555</p>	<p>ODOT's Bicycle and Pedestrian Program administers two grant programs to assist in the development of walking and bicycling improvements: local grants and Small-Scale Urban Highway Pedestrian Improvement programs. For both these grants, cities that have adopted plans with identified project will be in the best position. Grant funds for highways, county roads and local streets where improvements are needed for bicycle and pedestrians and/or bicyclists. Eligible project types include: ADA upgrades; completing short sections of missing sidewalks or bike lanes; street crossing improvements; intersection improvements; and minor widening for bike lanes or shoulders. Grant awards up to \$100,000 based on past trends.</p> <p>http://www.odot.state.or.us/techserv/bikewalk/funding.htm</p>

Funding Source / Contact	Program Description
21 st Century Community Fund	The 21 st Century Community Fun leverages existing revenues from both the Oregon Lottery and transportation funds to invest in affordable housing, transportation, water, sewer, and main streets. This fund specifically targets rural and economically distressed communities, providing funding for passenger rail and connecting buses, elderly and disabled transit services, access and right-of-way purchase, and improvements to the local street network.
Oregon Special Public Works Fund	The Special Public Works Fund, through OECD, distributes grant and loan assistance from the Oregon Lottery for economic development projects in communities throughout the state. To be awarded funds, a project must support businesses wishing to relocate, expand, or remain in Oregon. SPWF awards can be used for improvement, expansion, and new construction of transportation facilities. The SPWF emphasizes loans to assure that funds will return to the state over time for reinvestment in other local economic development projects.
Oregon Transportation Infrastructure Bank	The Oregon Transportation Infrastructure Bank is a project financing tool for Oregon communities to help meet need for transportation system maintenance and improvements. As a project financing tool, the OTIB works much like a private bank. It provides project loans and a range of credit enhancement services to help finance eligible transportation projects. Eligible projects are projects that meet federal-aid highway criteria or meet the definition of a transit capital project. The OTIB has approved loans varying in size from \$170,000 to \$5 million.
Economic Development Administration Community Development Block Grants	Construction and/or improvement of a wide variety of facilities and infrastructure that will primarily benefit low-moderate income persons. Grants and loans for projects that benefit low and moderate income households. Section 108 loans can leverage \$1m or more but have strict procurement rules. Eligible project types typically include infrastructure and in particular ADA and pedestrian accessibility improvements. (\$ of grant awards: vary)
Oregon Community Block Grant Program Contact; Michelle Bilberry 503.986.0142	Grants for infrastructure improvements needed to support a business that will create or retain permanent jobs, the majority of which will be made available to low and moderate income workers. For public infrastructure projects, the ratio is one job per \$20,000 invested. (\$ of grant awards: vary) http://www.econ.state.or.us/cdbg.htm
Immediate Opportunity Grant Program	The Oregon Economic and Community Development Department (OECD) and ODOT administer a program designed to assist local and regional economic development. The primary factors in determining eligible projects for the immediate Opportunity Fund Program are improvement of public roads, inclusion of an economic development-related project of regional significance, creation or retention of primary employment, and ability to provide local funds (50/50) to match grant. The maximum amount of any grant under the program is \$500,000.

Funding Source / Contact	Program Description
USDA Grants	<p>Grants and loans for rural infrastructure along with loans to distressed communities. (\$ of grant awards: vary)</p> <p><i>/www.rurdev.usda.gov/rd/nofas/index.html</i></p>
Urban Forestry Grants	<p>The Oregon Department of Forestry's Urban and Community Forestry Unit supports the stewardship of Oregon's urban and community forests. Through the Urban Forestry activities, on-site technical and financial assistance is available for communities, nonprofit groups, and civic organizations who want to plant and properly maintain trees within their urban areas, especially street trees.</p>
ODOT Special City Allotment (SCA) Programs	<p>The Legislature mandated \$1 million in state gas taxes to be distributed annually among cities with populations of less than 5,000. ODOT sets the distribution and dollar amount by agreement with the League of Oregon Cities. Half of the funds come from the cities' share of gas tax revenues and the half comes from ODOT's share of the State Highway Fund. Locals can receive \$25,000, one-half the maximum grant amount, up front, with final payment due upon completion of the project. Payments are included in the expenditure budget for Local Government in the Highway Program. (Note: A similar program exists for small counties. However, funds are transferred directly and are not contained as a budget expenditure.)</p> <p><i>http://www.odot.state.or.us/lgs/funding.html</i></p>
Low Interest Loans	
<p>Oregon Transportation Infrastructure Bank</p> <p>Contact: Paul O. Cormier (503)986-3921</p>	<p>The OTIB is a statewide revolving available to port districts to fund long-term (up to 30-years) low interest loans designed to promote innovative transportation funding solutions. Project must be Federal-Aid eligible (this may require re-designation of access road to achieve appropriate status). Eligible costs include engineering, environmental permitting, right-of-way, construction and project management.</p> <p><i>http://www.oregon.gov/ODOT/CS/FS/otib.shtml</i></p>
<p>Special Public Works Fund</p> <p>Contact: Tom Meek 503-986-0134</p>	<p>The Special Public Works Fund program provides funding for the infrastructure that supports job creation in Oregon. Loans and grants are made to eligible public entities for the purpose of studying, designing and building public infrastructure that leads to job creation or retention.</p> <p>The 2001 Legislative Assembly expanded the program to help municipalities cope with financial loss associated with natural disasters. For emergency projects eligible municipalities can apply for funding to meet the match required to receive federal funds.</p>

Funding Source / Contact	Program Description
	http://www.econ.state.or.us/spwf.htm
USDA Loans	<p>Grants and loans for rural infrastructure along with loans to distressed communities.</p> <p>http://www.rurdev.usda.gov/rd/nofas/index.html</p>
Local	
Local Capital Improvement Program	City can fund public facilities using general funds or dedicated revenues. However, this is not usually applicable, since general funds are usually "over committed" by various city services.
Local Property Tax Levies	City can fund roads, schools, parks, and other facilities through voter-approved referendums, subject to Oregon law. Typically the <u>primary revenue source</u> for local governments to upgrade public infrastructure. Property taxes go into general fund operations and are not used in most Oregon cities for street improvements or maintenance. Not usually a viable of funding for single projects that cost less than \$2,000,000.
Gas Tax Revenues	In Oregon, the state collects gas taxes, vehicle registration fees, overweight and overheight fines, and truck taxes and returns a portion of the revenues to cities and counties. Oregon cities typically use their state gas tax allocation to fund street construction and maintenance. However, these funds can be used to make any transportation-related improvements only within the public right-of-way, including sidewalks, intersection upgrades for pedestrians and bicycle lanes.
Local System Development Charges	Development impact fees, directly related to the proportional share of capital costs. Becoming an increasingly popular way to fund <u>public works</u> infrastructure needed for new development. Applicable to sewer and water systems.
Transportation System Development Charges (SDC)	A transportation system development charge or traffic impact fee can be charged to new development to pay for infrastructure improvements needed to serve new development. Cities throughout Oregon <u>use transportation system</u> development charges or impact fees to assist in funding traffic improvements related to the development.
Reimbursement District or Zone of Benefit District	Public or private entities that build road systems can be compensated by future property owners at a proportional rate, as development occurs. Usually limited to private construction of roads, this mechanism can <u>be useful for public/private</u> developments
Advanced Financing Agreements	Private entities that build public facilities can be compensated by the city as development occurs. Limited to private construction of public facilities, this mechanism is useful for public/private developments.

Funding Source / Contact	Program Description
Local Improvement District (LID)	LIDs can be formed by petition and subsequent legislative action under Oregon Law. They are often used to finance public infrastructure (roads, sidewalks, bikeways, sewer, water, etc.) using guaranteed payments from affect properties with a lien placed on those properties until the LID share is paid off. They typically require at least 51% of affected properties to approve the LID.
Urban Renewal District	Urban Renewal Districts can be formed by legislative action under Oregon law (with acknowledgment of an Urban Renewal Plan). Project financing is secured <u>through dedication of increases in tax increment revenues in the affected district.</u> Within an Urban Renewal District boundary, property taxes are collected at a rate that is frozen at the time of creation. Increases in the property taxes create the increment financing and are earmarked for special capital improvement projects within the district. The City of Milton-Freewater currently has an Urban Renewal District.
Economic Improvement District	And Economic Improvement District is a funding mechanism where the assessments are based on property assessment values or are a simple fee on property. EIDs cannot fun capital improvement projects, but they generally fund smaller projects and programs that can complement larger downtown improvements. EIDs are limited to a five-year duration and can be renewed.
Business Improvement District	A Business Improvement District works much the same as an EID, except that the assessments are paid by business owners rather than property owners. BIDs cannot pay for capital improvements, but may fund smaller projects and programs that support other downtown improvements. A BID can have a time limit, or can be perpetual.
General Obligation Bonds (G.O. Bonds)	Bonds are often sold by a municipal government to fund transportation (or other types) of improvements, and are repaid with property tax revenue generated by that local government. Under Measure 50, voters must approve G.O. bond sales with at least a 50 percent voter turnout. Cities all over the state use this method to finance the construction of transportation improvements. For smaller jurisdictions, underwriting costs can become a high percentage of the total financing cost for bond issues. "Bond Pools" such as those associated with the Oregon Infrastructure Bank (see above) assists small jurisdictions by pooling together several small bond issues, thereby achieving economies of scale with lower financing costs.
Revenue Bonds	Revenue Bonds include bonds sold by a city and repaid from an enterprise fund that has a steady revenue stream such as a water or sewer fund. Revenue bonds are typically sold to fund improvements in the system which is producing the revenue. Revenue bonds are a common means to fund large high cost capital improvements with a long useful life. A water or sewage treatment plant are examples where high construction cost over a short period makes it difficult to pay for the project with operating funds. However, the long-term revenue stream from user revenues makes the sale of bonds a viable alternative, with the cost of the facility spread over a long time period.
	Other

Funding Source / Contact	Program Description
Meyer Memorial Trust	<p>In rare instances, foundations or trusts may award grants to help fund civic improvements, including roads, parks and civic buildings. The largest share of the dollars the Trust awards each year is made under the General Purpose Grants program. General Purpose Grants support projects related to arts and humanities, education, health, social welfare, community development, the environment and a variety of other activities. Proposals may be submitted at any time under this program, and there are no limitations on the size or duration of these grants</p> <p>Applicants normally have tax exemption under Section 501(c)(3) of the Internal Revenue Code, and have been determined not to be a "private foundation" under Section 509(a) of the code. The Trust also awards grants to applicants that have federal tax exemption under other designations, such as public schools and government entities.</p> <p>http://www.mmt.org</p>
Private Donations	<p>Donations from individuals or corporations can be collected from cities or 501(c)3 profits to be used for various elements of public street improvements, such as paving (bricks), landscaping and benches.</p>

Site Furnishings

The section below contains information regarding proposed site furnishings (photos are also attached to this memo). The City of Milton-Freewater should continue to use the street lights and tree grates that were selected on prior projects to provide continuity throughout the city.

- Benches: Manufactured by Keystone Ridge Designs (1-800-284-8208), model numbers RE24, RE26, RE28, RE14, RE16, and RE18. Benches, both with backs and without, come in a range of lengths to best suit the specific site placement. Benches can be ordered in a range of colors and can incorporate logos.
- Litter Receptacle: Manufactured by Keystone Ridge Designs (1-800-284-8208), model numbers RE3-22, RE3-32, and RE3-38. The litter receptacle is from the same series as the bench for a coordinated look. The round receptacle was chosen and comes in three different sizes. Litter receptacles can be ordered in a range of colors and can incorporate logos.
- Bicycle Rack: Manufactured by Keystone Ridge Designs (1-800-284-8208), model numbers SN01-3, SN03-5, SN05-7, and SN07-9. The bike rack comes in a variety of lengths to fit specific site applications. Bike racks can be ordered in a range of colors.

- Drinking Fountain: Manufactured by Murdock Fountains (1-800-45-DRINK), model 1776 Old Style.

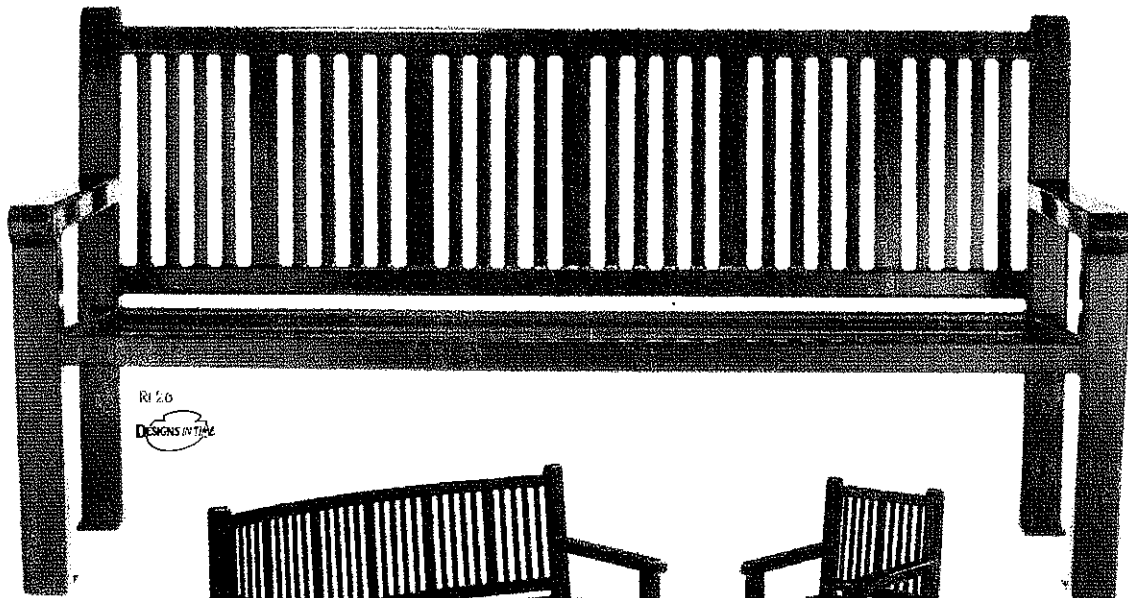

RE20
DESIGNS IN TIME

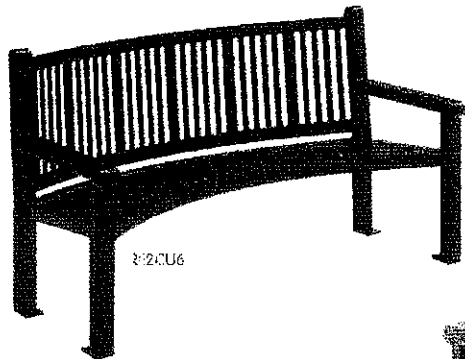

RE2CU6



RE22

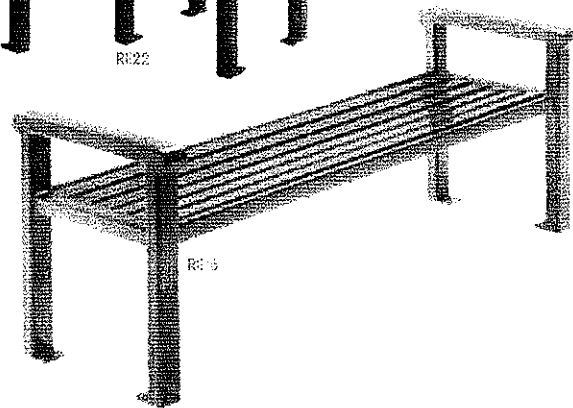

RE18

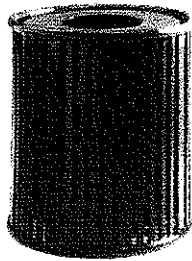

RE3-32

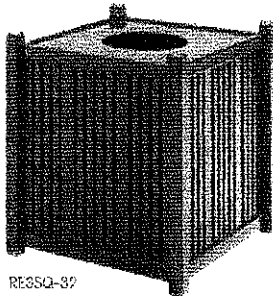

RE3SQ-32



RE24-6



READING

Reading benches with back is covered by patent no. 4,376,771. All other reading pieces are Products by Design™

RE22 Reading chair \$760

RE24	Reading bench with back 4'	\$810	
RE26	Reading bench with back 6'	\$910	
RE28	Reading bench with back 8'	\$1110	

RE14	Reading flat bench 4'	\$640	
RE16	Reading flat bench 6'	\$700	
RE18	Reading flat bench 8'	\$800	

RE2CU6	Reading curved bench with back 6'	\$1215	
RE2CU8	Reading curved bench with back 8'	\$1400	

RE24-6	Reading tree bench with back	\$1690	
RE14-6	Reading flat tree bench	\$690	

RE3-22	Reading litter receptacle 22 gal.	\$555	
RE3-32	Reading litter receptacle 32 gal.	\$595	
RE3-38	Reading litter receptacle 38 gal. NEW EXCLUSIVE	\$145	

RE3SQ-32	Reading square litter receptacle 32 gal.	\$765	
RE3SQ-38	Reading square litter receptacle 38 gal. NEW EXCLUSIVE	\$855	

See Keyselector™ menu system on page 47 for standard features, specifications and options



NEW EXCLUSIVE

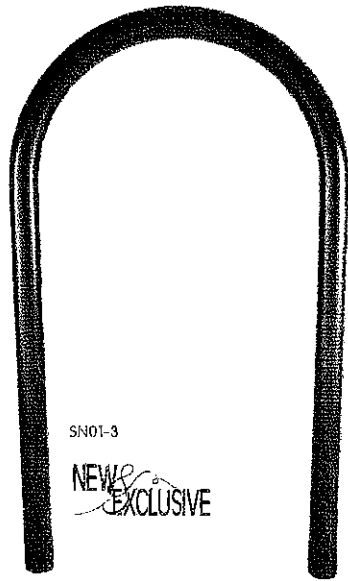
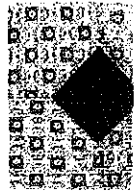

SN01-3

NEW EXCLUSIVE

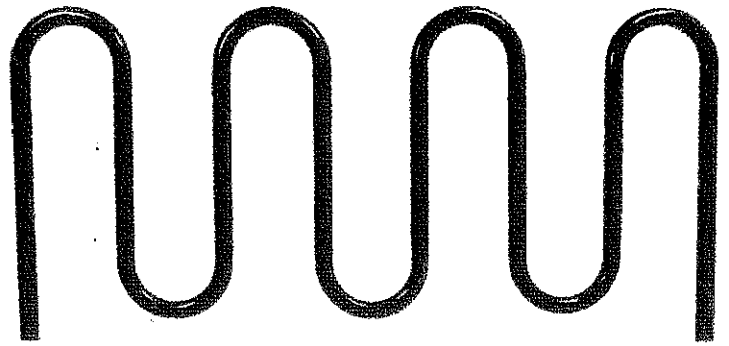

SN07-9

NEW EXCLUSIVE

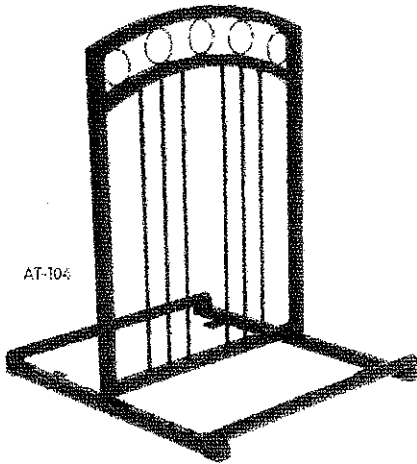

AT-104

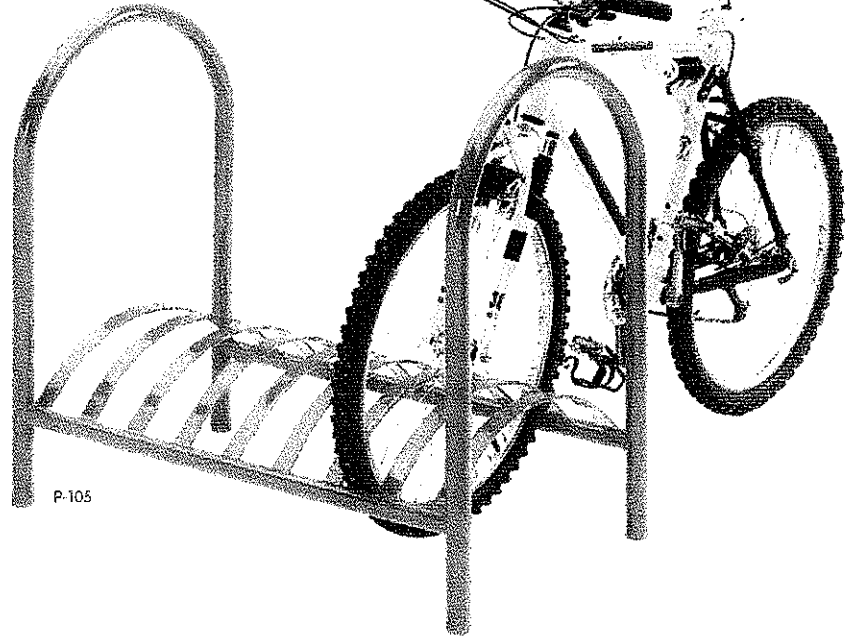

P-105

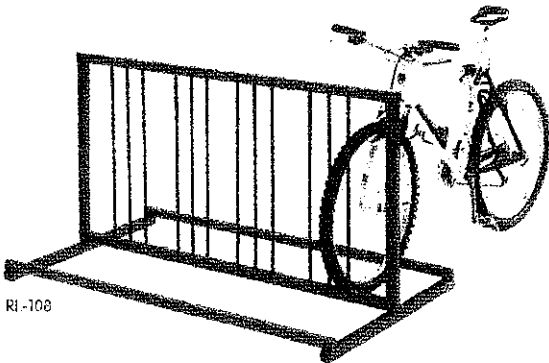

RE-104

BIKE RACKS







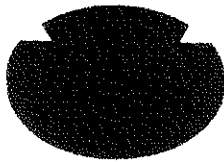
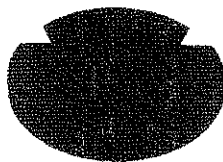
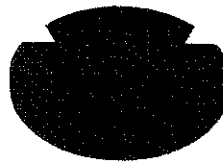

Bike racks are exclusive by design™.

AT-104	Atlanta bike rack capacity 4	\$575
AT-106	Atlanta bike rack capacity 8	\$675
P-105	Pullman bike rack capacity 5	\$350
RE-104	Reading bike rack capacity 4	\$335
RE-106-1	Reading one-sided bike rack capacity 6	\$495
RE-108	Reading bike rack capacity 8	\$435
SN01-3	Sonance one loop bike rack capacity 3	\$215
SN03-5	Sonance three loop bike rack capacity 5	\$425
SN05-7	Sonance five loop bike rack capacity 7	\$495
SN07-9	Sonance seven loop bike rack capacity 9	\$560

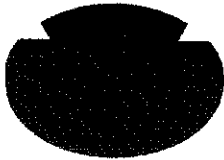
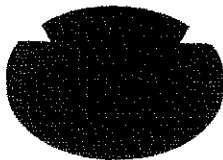
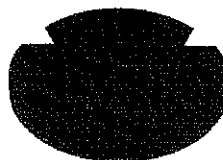
NEW EXCLUSIVE

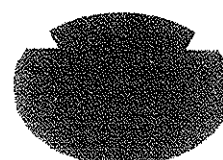
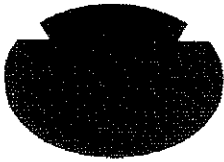
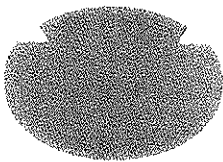
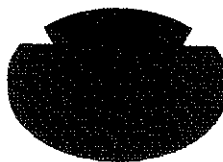
See the Keyselector™ menu system on page 47 for standard features, specifications and options.

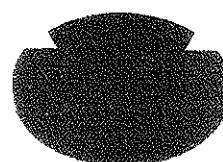
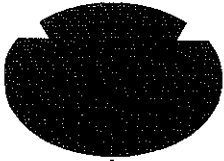
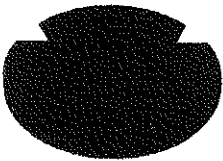
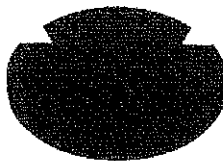
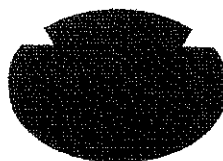
KEYSHIELD® Standard Powder Coat Colors

HERITAGE	SHORELINE	LANDMARK	ARCHITECTURAL	CAROUSEL
 AMERICANA RED	 DRIFTWOOD	 MIDNIGHT BLUE	 MOSS	 KIWI
 CADET BLUE	 OCEAN BLUE	 BURGUNDY	 MOSS	 LAVENDER
 HUNTER GREEN	 TROPICAL ORANGE	 EVERGREEN	 BRONZE	 COTTON CANDY
 BLACK	 NANTUCKET BLUE	 CHARCOAL	 MULBERRY	 WHITE

Colors may vary slightly due to printing processes. An additional 160 custom colors and color matching are available upon request. Colors are metal sample; availability upon request.



SUPPORT OPTION:
Roll down



SUPPORT OPTION:
Secondary anchoring

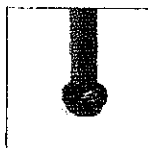

SUPPORT OPTION:
Glide



SUPPORT OPTION:
Elevated leg



SUPPORT OPTION:
Adjustable leg

CORIAN® Corian® is a DuPont registered trademark for its surfacing material. Only DuPont makes Corian®.

sunbrella® Sunbrella® is a registered trademark of Glen Raven Mills, Inc.

3M™. All rights reserved.

KEYSHIELD® Metal Finish

The KEYSHIELD® finish protects each piece of furniture from chipping, cracking, UV damage and provides unparalleled corrosion resistance. KEYSHIELD® is a strength, durability and quality - our assurance of a more durable life. Each product is finished with a two-coat powder coating process applied to a 7-15 mil thickness. Substrate preparation includes sandblasting to a white finish to remove all surface contaminants, the ultimate degree in power coat preparation. The raw product then receives a corrosion-inhibiting phosphite coating, per TTC-99 method 1, prior to the application of the powder coating. The first coat applied to the substrate is zinc rich epoxy powder primer used exclusively on sandblasted parts. The second coat is a colored polyester powder coating. Both coats are electrostatically applied and oven cured according to powder coating manufacturing specifications to create a smooth, stain-free finish. The result of this two-coat process is an optimum non-porous film that delivers the Keystone Ridge Design® stamp of quality. Keyshield® is a registered trademark of Keystone Ridge Designs, Inc.

Hardware: Keystone Ridge Designs, Inc. utilizes high-quality stainless steel assembly hardware where applicable. Anchoring hardware, due to the specialization required for each installation, is not supplied.



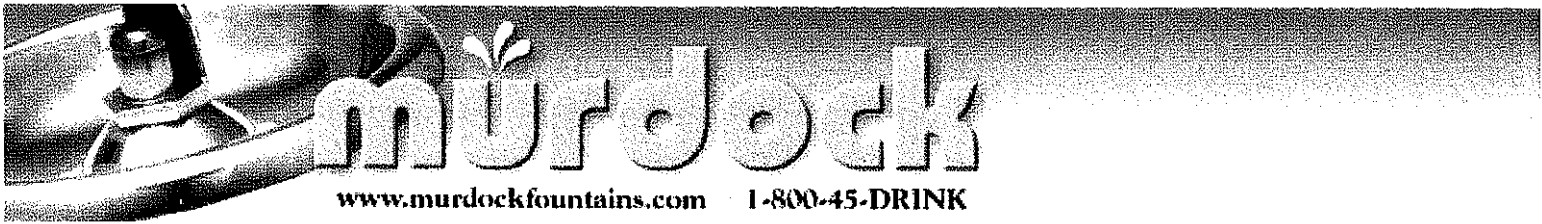

Home
Historical
Fountains
Flush Boxes
Hydrants
Safe Water

Specifications
Auto CAD
Parts
News-Special
Catalog
Q & A



1776 Old Style

■ Specifications.pdf ◆ Parts.pdf ● AutoCad.dwg(download)

The anti-freezing, pedal operated 1776 Old Style is a Murdock original design. With a decorative cast iron pedestal and brass polished bowl and bubbler, this fountain is the choice for historic parks or theme settings, and quite popular with streetscapes.

Murdock, Inc.
2488 River Road
Cincinnati, Ohio 45204

Voice: 513.471.7700
Fax: 513.471.3299
E-mail: info@murdockfountains.com

\$ 1500.00

Overall, the goals of the STA are to increase the vibrancy of Downtown Milton-Freewater, reduce vehicle travel speeds, increase pedestrian safety, and encourage non-auto modes of transportation.

Preferred Redevelopment Option

Convert Main Street to a three lane facility through the Downtown and Civic Districts.

This option combines converting Main Street to a three-lane facility through the Downtown and Civic Districts while keeping the remaining corridor four lanes and improving it with traffic calming features.

Alternate Redevelopment Option Two

Convert Main Street to a three lane facility.

This option converts the entire length of Main Street to a three-lane facility to slow traffic and provide more public space for pedestrians, bicycles and aesthetic uses.

Alternate Redevelopment Option Three

Maintain Main Street as a four-lane facility and provide curb extensions at key intersections.

This option maintains the existing street cross section while providing additional traffic calming measures throughout the corridor. These features would decrease the crossing distance for pedestrians by providing visual cues for motorists to travel at slower speeds. Curb extensions, street trees, visual cues, light poles, and safer crossing conditions would be implemented.

Traffic Operations

Preferred Redevelopment Option: Convert Main Street to a three lane facility through the Downtown and Civic Districts.

Additional study needs to be performed on this option, but the initial study suggests that it will accommodate the traffic load and the intersections would operate at a normal level.

The City of Umatilla has been discussed as a comparable example. It similarly incorporates two travel lanes with a median and center turn lane through the downtown area. Traffic counts between the two cities are slightly different, but within a comparable range. The City of Milton-Freewater experiences 10,400-13,400 ADT while the City of Umatilla experience between 7,900-9,800 ADT.

Option Two: Convert Main Street to a three lane facility.

According to the report provided by Kittelson & Associates, Inc., with the three lane scenario, all the intersections would continue to operate under capacity during both the weekday a.m. and p.m. peak hour periods.

Option Three: Maintain Main Street as a four-lane facility and provide curb extensions at key intersections.

Implementing traffic calming features would not impact vehicle capacity and therefore the system would operate as forecast in the no-build conditions outlined in the Kittelson & Associates, Inc. report.

Traffic Signals

The City will likely need a strong advocate to get a pedestrian activated crossing signal placed in the Main Street corridor. ODOT may or may not approve a pedestrian activated crossing signal due to traffic volumes that would not reach the threshold for requiring one.

A full traffic signal will likely be hard to justify to ODOT. The community would likely need to close side streets to drive up traffic volumes enough to warrant a signal. For example, if a signal was placed at the intersection of 9th and Main, 8th and 10th streets would need to be closed. Initially it seems unlikely that ODOT would approve a full signal based on existing traffic volumes.

If the City decides to pay for and install an un-warranted traffic or crossing signal, it is likely that they would be required to be responsible for any liabilities (i.e. a pedestrian gets hit in the crosswalk).

Public infrastructure

Parking

It is essential to provide on-street parking in front of businesses in the Downtown and Civic Districts. The higher density of commercial establishments in the area contributes to the high parking demand. For most downtowns, the parking demand is highest during the mid-day period or just after lunchtime in the early afternoon. Public off-street parking is available in the study area and is provided in four off-street parking lots in the corridor. These four lots provide approximately 130 parking spots for public use.

In addition, several private retail/commercial businesses in the study area have dedicated parking spaces for customers and employees. The majority of these lots are found at the north end of the corridor and supply approximately 180 business off-street parking spaces.

In the future, if parking demand increases dramatically, it is possible that the private business parking spaces could be integrated into the public supply as part of an overall parking management plan for downtown.

Access

According to the 1999 OHP, if a section of statewide highway is designated as Special Transportation Area (STA), as planned for ORE 11 through Milton-Freewater, "direct street connections and shared on-street parking are encouraged" and "local auto, pedestrian, bicycle, and transit movement to the area are generally given more importance than the through movement of traffic." In case of public roadway spacing, the existing city block or the city block spacing as identified in the local comprehensive plan is an accepted norm. For private driveways, minimum driveway spacing of 175 feet, measured from center to center on the same side of the roadway is allowed.

A majority of the existing accesses do not meet the ODOT access spacing standard for an STA. Nonetheless, due to the low traffic volume in the area, and historically low number of crashes, the existing accesses are anticipated to operate safely and acceptably. Any future development in the corridor should be encouraged to meet the spacing standard and ensure that proposed driveways operate safely.

Bicycle Facilities

There are currently no striped bicycle lanes through the study area. At the first Public Open House residents voiced strongly that they did think it was appropriate to have striped bike lanes on Main Street. However, there are a few people in support of having bike lanes, striped or un-striped, as part of Main Street.

The existing Right-Of-Way does not have enough room to accommodate the existing four lanes of traffic, parking on both sides of the street and a striped bike lane the entire length of the corridor. Residents were unwilling to give up parking in order to provide bicycle lanes.

The proposed three lane configuration has enough room to accommodate travel lanes, parking on both sides of the street and marked bicycle lanes. However, residents again voiced at the first Public Open House that they did not want bike lanes on Main Street. In all cases they would prefer that bike routes be designated on parallel streets to Main Street, such as Columbia Street and Mill Street.

At the second Open House citizens again voted against incorporating striped bike lanes on Main Street. In addition to safety concerns due to possible conflicts with large trucks, the preferred option incorporates four lanes of traffic which does not allow enough room to also have bike lanes.

Transit

Milton-Freewater recently started bus service again that provides local connection throughout Milton-Freewater as well as connections to Walla Walla. Proposed improvements should accommodate bus facilities and plan for future expansion of the transit system

Land uses, types, and densities.

The existing land uses, types, and densities found along Main Street are as follows:

Residential Low Density (R-1)

As seen on Figure 1.1, the R-1 zoning district is located on one block on Main Street, just north of City Hall. The intent of R-1 is to provide for larger, more secluded, home site with a maximum of four units per acre.

Residential High Density (R-3)

As seen on Figure 1.1, the R-3 zoning district is located mostly on southern Main Street. The intent of R-3 is to provide the widest range of housing alternatives including multi-family units. A maximum density of 26 units per acre is permitted.

Residential Office (R-O)

As seen on Figure 1.1, the R-O zoning district is located on Main Street, mostly between 7th and 9th Avenues. This zoning district is intended to encourage a compatible mix of residential development and small private or public offices.

The intent of R-O is to allow a mix of office and residential uses while still maintaining the residential character of the neighborhood. This balance must be achieved with all proposals. R-O zone is only allowed when abutted by a commercial zone, 75% of the lots are developed, and at least 50% of the uses are nonconforming in a Residential zone.

Retail and Service Commercial (C-1)

As seen on Figure 1.1, the C-1 zoning district is located on Main Street, in northern Milton-Freewater and between 9th and 13th Avenues. This zoning district is intended to provide for general retail and light service commercial uses such as hair salons, restaurants, and supermarkets.

General Commercial (C-2)

As seen on Figure 1.1, the C-2 zoning district is located on Main Street, between 9th and 11th Avenues. This zoning district provides for commercial services such as auto repair and building supply outlets. The uses in this zone involve heavier traffic than C-1 uses.

Public Lands (PL)

As seen on Figure 1.1, the PL zoning district includes City Hall and the Library on Main Street. The public lands zone provides for a full range of structures, services, and land uses provided by public agencies on publicly-owned land. A Site Plan Review process is used to determine some code requirements.

The following is an existing land use that is not found directly adjacent to Main Street, but is found within the study area:

Residential Medium Density (R-2)

As seen on Figure 1.1, the R-2 zoning district is located on residential streets, a block off Main Street. The intent of R-2 is to provide a greater range of housing types and densities than R-1, while maintaining the character of a single-family neighborhood. Up to 16 units per acre are permitted in R-2.

Impact to codes and policies

The impact to codes and policies is explained in detail in the Zoning Code and TSP Amendments memorandum.

Private or public development projects in the downtown

The Opera House has great potential for becoming a landmark for the downtown area of Milton-Freewater. There are several other buildings listed on the Historic Register in the area and a historic "focus" could be developed as a point of interest for visitors. The historic focus could help draw tourism spending which would in turn support commercial as well as arts, entertainment and recreation and accommodations and food service. The City should develop programs to assist owners and operators of these shops to upgrade their facilities through coordinated efforts which are sensitive to the historic and architectural values.

During the second Open House citizens responded favorably to allowing the residential areas in the Gateway Zones adjacent to Main Street to be allowed to operate home-based businesses. In order for the downtown area to draw more business, flexibility should be given to the corridor to allow businesses to develop while still retaining the unique residential setting.

In addition, lots for potential redevelopment have been identified. Some of the lots are vacant and are ready for redevelopment while other lots are more appropriate for future redevelopment opportunities after their current land use changes.

Potential environmental issues

No potential environmental issues have been discovered at this point of the study that would impact this project.

Preliminary Cost Estimates

Preliminary draft cost estimates are included as part of this report. They are an initial look at the costs and should be used for planning purposes only.



Memo

17355 SW Boones Ferry Road
Lake Oswego, OR 97035
Phone (503) 635-3618
Fax (503) 635-5395

Project: Milton-Freewater
Project No.: 12679
Date: March 28, 2005
From: Kate Schwarzler
Regarding: SHPO Information

According to the State Historic Preservation Office (SHPO), the Opera Building located at the corner of SW 10th Avenue and Main Street does not appear to have any documentation or review regarding placement of the building on the National Register of Historic Places or the State Inventory.

In order to get a building listed, the City would need to contact SHPO and ask for a Preliminary eligibility Evaluation packet. This packet explains the process and has a preliminary information form that needs to be filled out and submitted to SHPO. After the form has been submitted, National Register staff will provide an opinion regarding the potential for the property to meet the National Register eligibility criteria.

Streetscape improvements will need to be coordinated with SHPO prior to and during the engineering phase of the projects. Improvements, depending on the nature of the changes, which do not fit with the historical character or history of Milton-Freewater may impact decisions to be able to create a Historic District in the future. Proposed changes should be as unobtrusive as possible. For example:

- Don't exaggerate bump outs with planters or trees at the corners;
- Brick pavers may be more appropriate than concrete on sidewalks;
- Trees shouldn't obscure buildings (and should be consistent with trees that were there historically, if possible).

Future projects may require the City to go through a review process with SHPO. The City can contact SHPO prior to the start of any future projects to coordinate.

- Kirk Ranzetta (503) 986-0678
- Sarah Jalving (503) 986-0679

Additional information has been attached to this memo, including:

1. Outline of the process to nominate property for the National Register.
2. National Register Benefits and Restrictions.
3. Historic Survey and Inventory database information.



Oregon Parks and Recreation Department: Heritage Conservation: National Register

Departments Divisions Offices Commissions



National Register of Historic Places

How do I list a property?

Anyone can nominate an historic property to the National Register of Historic Places. However, if the property is privately owned, consent from the property owner is required before the property can be officially listed. In the case of a historic district, a majority of property owners must object in order to stop a listing. Owner consent is not required to list public property, however, we urge anyone who is interested in listing a public property to work closely and collaboratively through the nomination process with the public entity that owns the property.



A successful nomination process can take up to one year from first inquiry. We advise people to allow 100-150 hours to prepare the actual nomination form. The SHPO maintains a list of consultants who research and prepare National Register nominations professionally.

7-Step National Register Nomination Process

1. Contact SHPO

If you are interested in nominating a property for listing in the National Register, the first step is to request the Preliminary Eligibility Evaluation packet by calling 503-986-0672. This packet includes a form that asks for descriptive and historical information about your property. You should complete this form and include some color snapshots of the property's interior and exterior, then return the form and photographs back to us. After evaluating your information, the National Register staff in this office will provide you with a professional opinion about the property's potential for meeting the National Register eligibility criteria.

2. Obtain Bulletins, Forms, and SHPO Supplementary Information

If the property appears to be potentially eligible for listing, we will respond by sending you: **A)** a sample nomination form and National Register Bulletins #15 ("How to Apply the National Register Criteria for Evaluation") and #16A ("How to Complete the National Register Registration Form"). These indispensable bulletins serve as the primary instructions and guidance material for preparing a nomination, a document that must conform to a highly specialized format. (The Oregon SHPO urges nomination preparers to read these bulletins in their entirety before beginning a nomination); and **B)** the Oregon SHPO Supplementary Information form, which clarifies and adds to the federal instructions, but does not replace them. Please note that this supplementary information supplants the state's former technical guide for preparing nominations.

The [National Register website](#) has many additional bulletins that you may find helpful. The National Register Registration Form and continuation sheets can also be retrieved from the National Register website; however, the Oregon SHPO provides an preformatted nomination form available in MS Word for your use that you may find easier to work with.

3. Prepare Form

There are many sources that will yield historical information about your property. The process for obtaining that information may differ from jurisdiction to jurisdiction. For information on researching historic properties, you can obtain National Register Bulletin # 39 from at the National Register web site.

A National Register nomination essentially consists of a four-page form and continuation sheets, photographs, and maps. You will find the data necessary to complete the form in National Register

Bulletin #16A ("How to Complete the National Register Registration Form"). A narrative architectural description and a narrative statement of significance follow the form on continuation sheets, and comprise the heart of a nomination. The statement of significance must be completed based on solid research and documentation. The Oregon SHPO strongly encourages the use of footnotes or endnotes when preparing the document.

4. Prepare Photographs

National Register Bulletin #16A ("How to Complete the National Register Registration Form") has explicit instructions about the photographic requirements of a National Register nomination form. The instructions must be followed exactly. In addition, be sure to consult the SHPO's National Supplementary Information on photographs for critical information and clarification on film, paper, processing, and labeling. The National Register has a bulletin on how to take better photographs for nominations.

5. Submit Nomination to the Oregon SHPO

Deadline dates for the submission of nomination materials correspond to the meetings held each year by the [State Advisory Committee on Historic Preservation \(SACHP\)](#). Nomination submission deadlines are as follows: **November 1** for the February meeting, **March 1** for the June meeting, **July 1** for the October meeting. Check the above SACHP link to obtain information on scheduled meeting dates.

Nominations must be received in our office on hard copy no later than the deadline date. Materials we receive by or on the deadline will be considered the final draft submission by the preparer. Partially completed nominations, or placeholders will not be accepted. Materials postmarked on the deadline date will not be accepted.

A nomination may not be scheduled for SACHP review until it is considered adequate to the documentation standards set forth by National Register Bulletin # 16A and the Oregon SHPO Supplementary Instructions. Our staff may request revisions to the nomination document before placing a nomination on the agenda for an upcoming meeting. Preparers are advised that the SACHP may request additional revisions after it has heard the nomination.

6. Make Revisions

When the SACHP approves a nomination, or approves it with conditions, the preparer may be asked to make minor corrections or additions to the document after the meeting. Once those revisions are completed, the nomination is sent back to the SHPO, where staff finalizes the document and ships it to Washington, D.C. office of the National Register. The National Register staff in Washington has 45 days to review the document and either approve or reject the property for listing in the National Register.

7. Receive Notification

Our office is notified of the decision by the Keeper of the National Register between 45 and 60 days after the date that we send the nomination to Washington. Property owners and interested parties are immediately notified of the outcome by a mailing from the SHPO.



Oregon Parks and Recreation Department: Heritage Conservation: National Register



National Register of Historic Places

Results of listing

National Register Benefits and Restrictions

The National Register program is a federal program administered at the state level by the State Historic Preservation Office (SHPO). The regulation of National Register-listed properties in Oregon takes place at the local level. The following benefits and restrictions apply to National Register-listed properties:



Benefits

- **Recognition** Owners may want receive an official certificate of designation and/or purchase an official plaque that can be placed on the building. Both of these are optional.
- **Eligibility for federal tax credit** The SHPO administers a federal tax credit program that can save building owners twenty percent of the cost of rehabilitating their National Register-listed commercial, industrial, or rental residential building. Requirements include submitting a short application form and performing only work that meets appropriate rehabilitation standards. Because tax aspects outlined above are complex, individuals should consult legal counsel, an accountant or the appropriate local Internal Revenue Service office for assistance in determining the tax consequences of the above provisions.
- **Consideration in planning for federal projects** Section 106 of the National Historic Preservation Act of 1966 requires that federal agencies allow for the Advisory Council on Historic Preservation to have an opportunity to comment on all federally licensed, permitted or funded projects affecting historic properties listed in the National Register. The Section 106 Review and Compliance Program is administered by the SHPO.
- **Oregon tax incentive** The Special Assessment for Historic Properties tax incentive program allows owners of properties listed in the National Register of Historic Places to have a "freeze" placed on the assessed value of the property for a 15-year period. The program is designed to assist property owners in the preservation of historic resources. State law establishes a requirement for a public open house once a year, the installation of a property identification plaque, and the option for commercial property owners to apply for an additional 15-year "freeze."
- **Building code leniency** Under Section 3403.5 of the Uniform Building Code/Oregon Structural Specialty Code, National Register properties, and other certified historic buildings, are eligible to be considered for waivers of certain normal code requirements in the interest of preserving the integrity of the property.
- **Grants** Competitive "Preserving Oregon" historic rehabilitation grants are available through the Heritage Conservation Division for properties listed in the National Register of Historic Places.

Restrictions

- **Local Government Protection** No restrictions are imposed by the State of Oregon or the federal government. However, state law does require local governments to offer some level of protection to National Register properties. Properties listed in the National Register of Historic Places are subject to protection under authority of Oregon Revised Statutes 197.772 and Oregon Administrative Rules 660-23-200 relating to historic resources and Statewide Land Use Planning Goal 5. Local jurisdictions (county or city) regulate National-Register-listed properties per their local ordinances, which means restrictions will vary from jurisdiction to jurisdiction. Contact your

local planning bureau to determine the level of regulation in your community.

Special Provisions

Private property owners may object to the listing of their property by sending a notarized letter to that effect to the SHPO prior to final review. Public entities are not allowed to prevent the listing of their properties. In the case of a historic district, a majority of property owners must object in order to stop a nomination. Individual property owners within a historic district may not "opt out" if the majority of owners have not objected. National-Register-listed historic districts, just like individually listed buildings, are subject to whatever local regulations apply (as described above).

Commenting on National Register Nominations

If you wish to comment on the nomination of a property to the National Register, please send your comments to the State Historic Preservation Office before the forthcoming meeting of the State Advisory Committee on Historic Preservation. A copy of the nomination is available from the SHPO upon request.

[Text Only](#) | [State Directory](#) | [Agencies A-Z](#) | [About Oregon.gov](#)
[Site Map](#) | [File Formats](#) | [OAR](#) | [ORS](#) | [Privacy Policy](#) | [Web Site Fe](#)



Oregon Parks & Recreation Dept: Heritage Conservation: State Historic Preservation Office



Survey and Inventory

Maintaining a statewide inventory of Oregon's historic and archaeological properties is one of the responsibilities of the State Historic Preservation Office as mandated by the National Historic Preservation Act of 1966 and Amendments. The surveys that contribute to this inventory provide important support to citizens, local governments, and federal and state agencies for identifying and protecting Oregon's cultural heritage resources.



Historic Survey and Inventory

A database called the Oregon Historic Inventory contains documents and electronic data from three survey methodologies:

- Historic surveys are conducted by historic preservation professionals often assisted by preservation graduate students or local volunteers. Neighborhood groups, local governments, and state or federal agencies may initiate surveys. Historic surveys are a fundable activity under SHPO's [Certified Local Government Grant Program](#).
- The National Register of Historic Places adds information to the Oregon Historic Inventory from data collected on National Register nomination forms required for the [National Register Program](#).
- The Section 106 Review and Compliance surveys add information to the Oregon Historic Inventory from data collected on forms required for the [Section 106 Review and Compliance Program](#).

The Oregon Historic Inventory is available for research purposes at the SHPO office. To review or conduct research in the Inventory, please make an appointment with SHPO staff by calling 503-986-0672. Simple questions may be answered via telephone. The database is currently undergoing revisions and will be available on this website when completed.

Please note that archaeological survey records and data are housed separately and not integrated into the Oregon Historic Inventory database. See the Archaeological Survey and Inventory section near the bottom of this page.

Contact

Kimberly Dunn, Historic Survey Coordinator

Phone: (503) 986-0670

Fax: (503) 986-0793

E-mail: kimberly.dunn@state.or.us

Historic Survey Publications & Forms

- Historic Survey Program Instruction Manual [[RTF 59 KB](#)] [[PDF 66 KB](#)]
- Historic Survey Instruction Manual Appendices [[RTF 666 KB](#)] [[PDF 107 KB](#)]
- Historic Resource Survey Form [[RTF 93 KB](#)] [[RTF 14 KB](#)]
- Historic Resource Survey Form Continuation Sheets [[RTF 13 KB](#)] [[PDF 10 KB](#)]
- Cover Sheet and Form for Resource Groups or Clusters [[RTF 23KB](#)] [[PDF 11KB](#)]

- [Instructions for the Historic Resource Survey Form \[RTF 36 KB \]](#) [[PDF 49 KB](#)]

Archaeological Survey and Inventory

Archaeological surveys are conducted by professional archaeologists and must be done according to the State of Oregon Archaeological Survey and Reporting Standards (see publication below).

All identified archaeological sites (both prehistoric and historic) and isolated finds need to be recorded on Oregon SHPO Archaeological Services' forms. These surveys and site forms must be completed to comply with the federal Section 106 compliance requirements as well as research conducted by universities, private consultants (see publication below), or Tribal archaeologists.

All survey documents are inventoried by the SHPO, and data is added to the archaeological database. Information on known archaeological sites is not available to the general public. Qualified archaeological researchers may make an appointment to search the archaeological files with the SHPO Archaeologist.

Contact

Dennis Griffin, Archaeologist

Phone: (503) 986-0674

Fax: (503) 986-0793

E-mail: dennis.griffin@state.or.us

Archaeological Survey Publications

- [State of Oregon Archaeological Survey and Reporting Standards \[PDF 151 KB \]](#)



[Text Only](#) | [State Directory](#) | [Agencies A-Z](#) | [About Oregon.gov](#)
[Site Map](#) | [File Formats](#) | [OAR](#) | [ORS](#) | [Privacy Policy](#) | [Web Site Fe](#)

M e m o r a n d u m



17355 SW Boones Ferry Rd
Lake Oswego, OR 97035
Phone (503) 635-3618
Fax (503) 635-5395

To: Milton Freewater Client
From: Jodie Vice, Todd Chase and Charlotte Larson
Copies:
Date: June 30, 2005
Subject: Economic and Existing Code Analysis
Project #: 12679

INTRODUCTION

This memorandum describes demographic, economic and regulatory conditions within the downtown Milton-Freewater area. This assessment of economic opportunities and constraints takes into account historical growth trends and future projections for market-supportable development and business growth potential.

Work completed by Otak included:

- Conducting a survey among local stakeholders to confirm downtown development and transportation issues, opportunities and constraints;
- Performing a demographic, economic and market assessment to understand downtown development potential for retail, commercial and tourist-related development; and
- Documenting preliminary regulatory issues and local comprehensive plan amendments that would likely be required to optimize development and redevelopment potential in downtown Milton-Freewater.

ECONOMIC ANALYSIS

Local Economic Setting

The Milton-Freewater economy revolves primarily around the regional agricultural-base which includes productive orchards, irrigated row crops and dry land wheat, pea and bean production. Related spin-off industries include food handling, processing, packaging, and shipping. Milton-Freewater's access to Interstate Highway 84, US Route 395, rail and water terminals enables regional agricultural goods to be efficiently shipped nationally, and exported to many countries around the world.

According to the Milton-Freewater Comprehensive Plan, "employment in the agricultural sector has historically been very volatile with most employees laid-off for several months during the

winter and early spring. This problem has eased considerably in recent years as more types of fruit have been introduced which expand the harvest season. Installation of new storage facilities and new processing lines has also allowed local packers and processors to extend employment seasons up to nine or ten months. This has naturally helped to stabilize income and settlement patterns of those employed in harvesting and processing."

Milton Freewater is located ten miles from the shopping districts of Walla Walla, WA (population 48,000). According to the local comprehensive plan, "Milton Freewater retailers lose a large percentage of the local shopping dollar to Walla Walla as residents make the short trip to access larger selection and volume pricing." This situation is accredited with inhibiting growth of the commercial sector particularly in areas as clothing, small and medium household appliances and dry goods.

The sales tax differential between Oregon and Washington provides some benefits to Milton-Freewater commercial businesses as Washington shoppers tend to make large purchases such as major household appliances, electronics and furnishings in Oregon.

Downtown Milton Freewater, like many older downtown locations in the United States has suffered from the development of large format retail centers that tend to be owned by national chains. According to the local comprehensive plan, "owing to its origin as two separate and competing towns, the City has two separate downtown sites, the south being old Milton and the north being old Freewater. The gap between these areas is becoming less of a difficulty as Main Street and Broadway Avenue slowly but perceptibly develop as a commercial entity between the two old downtowns."

The local comprehensive plan recognizes the role of commercial retail strip development along Hwy. 11, north of Main Street. The comprehensive plan indicates that "this commercial area has largely developed since expansion of the highway in 1973. Again, Broadway is developing as a desirable commercial link between this area and the Main Street development."

According to a survey of businesses, most commercial development along Highway 11 appears to be less than 20 years of age and in relatively good physical condition. There also appears to be several infill and redevelopment opportunities within the corridor. The following is a list of local businesses relevant to the study area at the time of the study:

Name	Address
Rite Aid Pharmacies	105 SW 2nd Ave
Nita's Valley Properties Inc	311 S Main
Mike's 2-Way Radio Service	321 S Main
Subway	322 S Main
Dennis Wallen Tax	405 S Main
McDonalds	406 S Main
Conoco Gas/Our Country Market	421 S Main
First Christian Church	518 S Main
Gildersleeve House	604 S Main
Presbyterian Church Grace	703 S Main
7th Day Adventist Church	713 S Main

U-Haul	725 S Main
Century 21 Seaquist & Associates	725 S Main
Keylock Security Storage	725 S Main
George Herbert Photography	801 S Main
Umatilla County Mental Health	808 S Main
Umatilla County Mental Health	810 S Main
Wesley United Methodist Church	816 S Main
Munselle-Rhodes Funeral Home	902 S Main
Sub Shop #38	4 SE 9th
CashCo	903 S Main
Headlines Styling Salon	905 1/2 S Main
Video Superstore	907 S Main
Hot Shots	907 1/2 S Main
LaMona's Ladies Apparel	909 S Main
Atty Millarr, A. Andy	920 S Main
Chevrolet Parts & Service	1003 S Main
Milton-Freewater Bar & Grill	1004 S Main
Liquor Store	1006 S Main
Carpet Warehouse	1008 S Main
Kennedy Mobile Vet	1016 S Main
Chriopractor Turner, Mark F.	1018 S Main
Premier Physical Therapy	1020 S Main
Tortilleria La Calandria	1105 S Main
Car Company	1112 S Main
M & C Machining & Manufacturing	1114 S Main
Zip Trip	1121 S Main
School's Community Credit Union	1221 S Main
Trails West RV Park & Campground	1420 S Main
Star Press	1510 S Main
Gordy Plastics	1530 S Main
Ironhorses	1560 S Main
Humbert Septic Service	1560 S Main
Tree Top Inc.	1565 S Main

The local comprehensive plan recognizes the importance of redeveloping the two downtowns. The plan states that "a pressing commercial need is for redevelopment and upgrading of the two old downtowns. Major revitalization has taken place in the south and north districts. These efforts have helped to bring new businesses and shoppers to the areas. It is vital that other store owners and operators continue the trend started by these projects so that everyone can benefit from increased shopping activity in the community. The city has provided technical help to shopkeepers and the Chamber of Commerce to initiate and assist these efforts. This will remain a high priority."

COMPREHENSIVE PLAN POLICY

Local economic development policies are intended to provide guidance to communities that are considering local initiatives to spur economic growth. The City of Milton Freewater's Comprehensive Plan identified the following economic development policies and conclusions, including:

- Milton Freewater will continue to update and improve its Economic Development Plan.
- The need for commercial lands will be met through the redevelopment potential of 12 acres identified in the buildable lands needs analysis.
- Milton Freewater will encourage efficient use of its commercial lands through the implementation of ordinances to share accesses and maximize parking.
- The proximity of grain from the wheat lands to the south and fruit from the orchard lands to the north appear to present good opportunities for secondary processing of these raw materials into forms such as pies and frozen specialty foods.
- Over-reliance on the orchard district north of the city can result in serious economic hardship in the event of major crop failure from weather or disease. While remaining heavily involved in agriculture, the economy needs to diversify to lower the risk inherent on a limited industrial base.
- Wall Walla and Milton Freewater retail sectors have strengths which can be used to the benefit of both. Cooperative promotion and marketing of the Walla Wall Valley should be a joint effort of both communities.
- The City will continue efforts to assist owners and operators of these shops to upgrade their facilities through coordinated efforts which are sensitive to the historic and architectural values.

MARKET OVERVIEW

Milton Freewater is located in Umatilla County at the southeastern edge of the Columbia River Basin in northeastern Oregon. The City has a population of 6,500 and is located on State Highway 11. The City is located 8 miles south of the Oregon/Washington border. The City has two established downtowns, reflecting the historical towns of Milton and Freewater. Milton is on the south side of the City and Freewater to the north. Outside downtown, commercial development extends along the Highway 11 corridor.

Population

According to the US Census Bureau, Milton Freewater's population consisted of 6,470 people residing in 2,504 dwellings during year 2000, up 17% percent from 1990. In comparison, Umatilla County's population consisted of 70,548 people in year 2000, up 19 percent from 1990. Approximately 9 percent of Umatilla County's population resides in Milton Freewater, as indicated on Table 1.

Table 1. Population Trends, 1990, 2000 & 2002

	1990	2000	2004*	% Change 1990-2000	% Change 2000-2004
Milton Freewater	5,553	6,470	6,500	16.9%	0.46%
Umatilla County	59,249	70,548	72,250	19.1%	2.4%

Oregon	2,842,321	3,421,399	3,582,600	20.4%	4.7%
United States	248,709,873	284,421,906		13.1%	--

Source: US Census for 1990 and 2000.

* Source: Center for Population Research, Portland State University

According to the Oregon Office of Economic Analysis (2004 population forecast), the Umatilla County population is projected to increase to 90,660 by year 2025. This increase of 18,410, or 25 percent, is slightly below the projected state increase of 29 percent.

Households

There were approximately 2,504 dwelling units counted by the US Census in Milton Freewater during year 2000, which indicates an 11% growth since 1990, as indicated in Table 2. The total housing stock in Umatilla County increased by 14 percent during the 10-year period between 1990 and 2000.

In 2000, the average household size in Milton Freewater was 2.77 people per dwelling compared with 2.67 for Umatilla County and 2.51 for the state of Oregon.

Milton Freewater and Umatilla County both have a greater propensity of owner households than renter households. Tenancy in Milton Freewater was estimated at 62% owner and 38% renter households, compared to statewide tenancy of 64% owner and 36% renter households.

Table 2. Household Trends, 1990 & 2000

1990	Total Hsg Units	Vacant Units	Vacancy Rate
	2,254	155	6.8%
Umatilla County	24,333	2,313	9.5%
Oregon	1,193,567	90,254	7.5%
United States	102,263,678	10,316,268	10.1%
2000	Total Hsg Units	Vacant Units	Vacancy Rate
Milton Freewater	2,504	267	10.6%
Morrow County	27,676	2,481	8.9%
Oregon	1,452,709	118,986	8.2%
United States	115,904,641	10,424,540	8.9%

Source: US Census for 1990 and 2000.

Income

Both Milton Freewater and Umatilla County's income levels are well below state and national averages. The median household income level in Milton Freewater was \$28,365 in 1999, which is 44 percent less than the statewide median household income level of \$40,916. See Table 3.

From 1990 to 2000, Milton Freewater's per capita income fell from 63 percent of the national average to 60 percent. Approximately 929 people in Milton Freewater were classified as "living at or below poverty" during 1999 (15% of the population).

Table 3. Income Trends, 1990 & 2000

1990	Median Household Income	Per Capita Income	Percent of National Average
Milton Freewater	\$18,759	\$9,130	63 31%
Umatilla County	\$22,791	\$11,178	77 52%
Oregon	\$27,250	\$13,418	93 05%
United States	\$30,056	\$14,420	
2000	Median Household Income	Per Capita Income	Percent of National Average
Milton Freewater	\$28,685	\$13,101	60 69%
Umatilla County	\$36,249	\$16,410	76 02%
Oregon	\$40,916	\$20,940	97 00%
United States	\$41,994	\$21,587	

Source: US Census

Employment

The civilian labor force includes primary employee candidates, between the ages of 16 and 65. As indicated in Table 4, Milton Freewater has experienced little employment growth since 1990, while Umatilla County's labor force expanded by over 100% (16,650 people) High unemployment continues to plague Oregon, particularly in rural counties. In January 2005, the Oregon Labor Market Information System reported that 10.9% percent of Umatilla County was unemployed, compared to 7.1 percent for state of Oregon and 5.5 percent for the nation.

Table 4. Labor Market Summary

	1990	2000	January 2003*	Annual Change 1990-2000
Milton Freewater				
Population 16 and over	4,156	4,551		40
In Labor Force	2,571	2,817		25
Civilian Labor Force	2,571	2,810		24
Employed	2,417	2,408		-1
Unemployed	154	402		25
Unemployment Rate	5.99%	14.31%		
Umatilla County				
Population 16 and over	28,016	53,222		2,521
In Labor Force	27,984	33,621		564
Civilian Labor Force	25,612	33,598		799
Employed	14,414	31,068		1,665
Unemployed	1,326	2,530		120
Umatilla County Unemployment Rate	5.18%	7.53%	10.9%	
Oregon Unemployment Rate	6.20%	6.47%	7.10%	
United States Unemployment Rate	6.31%	5.77%	5.50%	

Source: US Census

*Source: Oregon Labor Market Information System

Leading employers in Region 12 (Umatilla and Morrow Counties), as of the fourth quarter of 2003, are summarized in Table 5. Major employers in the region specialize in grain and agricultural packaging, shipping and processing. Super-regional warehousing and distribution activities, by Wal-Mart and Union Pacific occur in light of the convenient interstate and rail access located near Hermiston. Major health services, retail and government operations also act as important employers.

Table 5. Major Local and Regional Employers

Location	Product/Service	Employees
Milton Freewater (Umatilla County)		
Sykes Enterprises, Inc	Customer Support Call Center	400
Milton Freewater Unified School District	Education	220
Oregon Coalition of Child Development	Child care	106
E. Brown and Sons Inc.	Apples	80
City of Milton-Freewater	Government	70
Hermiston Area (Umatilla County)		
Wal-Mart	Distribution	1,000
JR Simplot	Food Products	850
Lamb Weston	Potato Products	500
Marlette Homes	Manufactured Homes	460
Hermiston Foods	Frozen Foods	450
Pendleton Area (Umatilla County)		
St. Anthony's Hospital	Public Hospital	280
Keystone RV Company	Travel Trailers	245
Fleetwood Travel Trailers	Travel Trailers	142
Pendleton Flour Mills	Flour	80
Hill Meat Company	Food Packaging	80
Umatilla Area (Umatilla County)		
Two Rivers Correctional Institution	Correctional Facility	500
JM Manufacturing, Inc	Polyvinyl Chloride Pipes	76
Gilroy Food	Dehydrated Onions	55
Boise Cascade	Wood Chips	20
Oregon Rustic	Pine Furniture Manufacturing	19
Heppner City (Morrow County)		
Morrow County Government	Government	120
Morrow County Health District	Government	110
Morrow County School District	Education	67
Bank of Eastern Oregon	Financial Services	20
Heppner Ranger District	Federal Government	N/A
Boardman Area (Port of Morrow)		
Lamb Weston	Potato Products	450
Watts Brothers Repackaging Facility	Distribution	95
Logan International	Distribution	120
Oregon Potato Company	Potato Products	110

Location	Product/Service	Employees
Boardman Foods	Fresh pack onions	100
Tillamook Cheese Processing Plant	Dairy Processing	60
Cascade Specialties	Distribution	70
Port of Morrow	Port Facilities Management	40
PGE Coal Fire Plant and Coyote Springs Co-Gen. Plant	Electrical Power	113

As indicated in Table 6, the leading job sectors in Umatilla Counties include government (7,890 jobs), retail trade (6,370 jobs) and services (5,920 jobs).

Table 6. Umatilla and Morrow County Job Distribution, 2002

Employment Sector (Non-farm payroll)	2002
Manufacturing	5,020
Construction and Mining	1,470
Transportation and Utilities	2,660
Wholesale Trade	1,090
Retail Trade	6,370
Finance, Insurance and Real Estate	930
Services	5,920
Government	7,890
Total	31,350

Within Region 12, Umatilla County has seen the bulk of the employment growth. According to the Unified Workforce Plan for Morrow Umatilla Region 12 Workforce Investment Board, Umatilla County added 1,490 non-farm jobs in 1998, more than other county outside a metropolitan area. Morrow County finished in fifth place in 1998 by adding 130 non-farm jobs to total 3,060 on an annual basis.

According to the Oregon Employment Department, total Region 12-employment was estimated at 31,350 in 2002, up 295 jobs from 2000. Long-term trends in non-agricultural employment for Region 12 point towards robust employment expansion in the retail trade; finance, insurance and real estate; and services; moderate growth in wholesale and government job sectors; and little growth for manufacturing, construction, mining, and transportation and utilities. Overall employment is expected to expand to 33,720 by 2012, an increase of 2,370 from 2002, as indicated in Table 7.

The Oregon Employment Department anticipates a continued shift in industrial job growth for Region 12 over the next 10 years—from lumber, wood and food products to miscellaneous durable and non-durable goods. The total amount of industrial jobs are projected to remain at 5,020 in Region 12, as job losses in are lumber, wood and food products are countered by job gains in other industrial sectors.

Table 7. Employment in Morrow and Umatilla Counties (Region 12)

Employment Sector (Non-farm payroll)	2002	2012 Projection	2002-2012 Change	2002-2012 % Change	Annual Change 2002-2012
Manufacturing	5,020	5,020	--	0%	--
Construction and Mining	1,470	1,230	(240)	-16.3%	(24)
Transportation and Utilities	2,660	2,200	(460)	-17.3%	(46)
Wholesale Trade	1,090	1,270	180	16.5%	18
Retail Trade	6,370	7,340	970	15.2%	97
Finance, Insurance and Real Estate	930	1,090	160	17.2%	16
Services	5,920	7,290	1,370	23.1%	137
Government	7,890	8,310	420	5.3%	42
Total	31,350	33,720	2,370	7.7%	237

Residential Demand

The demand for new housing in Milton Freewater will be a function of local population levels, household size, income and area amenities, such as schools and cost of living.

Future housing demand in the County is expected to remain steady, with a projected 8,836 new dwellings needed over the next 20 years, as indicated in Table 8. This equates to average annual housing absorption of 400 units per year over the planning period.

If we assume there to be a competitive vacant supply of buildable land and/or redevelopment sites in Milton Freewater (and adequate public water and sewer facilities), Milton Freewater could capture between 10% and 15% of the future County housing demand. This equates to between 884 and 1,325 dwelling units over 20 years. It is possible that downtown Milton Freewater could accommodate some of this demand through a combination of upper-level redevelopment, infill development with limited opportunities for new construction.

Table 8. Projected Housing Demand in Umatilla County and Milton Freewater

	2004	2025
County Population	72,250	90,660
Estimated Population in Group Quarters*	3,324	4,170
Population in Households	68,927	86,490
Estimated Average Household Size	2.60	2.50
Estimated Households	26,510	34,596
Change in New Households		8,086
Move Up / Replacement Demand (1% of housing stock)		346
Vacancy Rate 5%		404
Projected Change in Housing Demand for County		8,836
Projected Change in Housing Demand for Milton-Freewater (Low Growth Scenario @10% capture)		884
Projected Change in Housing Demand for Milton-Freewater (High Growth Scenario @15% capture)		1,325

*Based on 2000 allocation of group quarters = .3% of population

Source: US Census and Office of Economic Analysis; analysis by Otak, Inc.

Commercial Demand

Future retail development potential depends on the ability for local retail establishments to “capture” existing and future household buying power. Table 9 summarizes the projected household buying power for Milton Freewater.

Table 9. Aggregate Income Levels in Milton Freewater, 2000 - 2025

2000 Pop*	6,470
Proj. 2025 Pop**	11,333
Est. 2000 Per Capita Income*	\$13,101
Proj. 2025 Per Capita Income***	\$16,376
Est. 2000 Aggregate Income	\$84,763,470
Proj. 2025 Aggregate Income	\$185,592,041
Change in Aggregate Income (2000 – 2025)	\$100,828,571

*Source: US Census

**Derived from State of Oregon Umatilla County Population Projection of 90,660; assumes Milton Freewater capture rate of 12.5%.

*** Assumes annual growth of .5%

An analysis of retail spending for Umatilla County demonstrates the retail sales inflow/outflow for the county. As indicated on Table 10, approximately 56% of retail buying power currently flows into the County from places outside the area (particularly from Washington State residents). Umatilla County residents currently spend an estimated \$130.8 million on retail purchases and county retail establishments take in approximately \$300 million on retail sales.

Table 10. Existing Retail Buying Power, Umatilla County, 2000* (thousands)

Store Group	2000 Retail Sales at County Retail Establishments	2000 Retail Expenditures by County Residents	Estimated Existing Retail Inflow/ (Outflow)
Total Retail Sales	\$993,122	\$435,073	\$508,049
Food and Beverage Stores	\$160,356	\$96,088	\$64,268
Food Service and Drinking Establishments	\$78,356	\$57,885	\$20,471
General Merchandise	\$186,217	\$63,673	\$122,544
Furniture and Home Furnishing and Electronic Appliances	\$27,572	\$25,469	\$2,103
Motor Vehicle and Parts Dealers	\$237,284	\$111,138	\$126,146
Other	\$303,337	\$130,819	\$172,518

Source: Sales and Marketing Management, Survey of Buying Power. Analysis by Otak, Inc.

The method used to estimate retail sales inflow/outflow follows the following steps: (1) estimate current retail sales by store group for county retail establishments using information from the U.S. Census of Retail Trade, or Sales and Marketing Management; (2) estimate the current level of supportable retail demand from local households by calculating aggregate gross income in the area and factoring that by average allocation of household income by retail expenditure (using information from the US Census and the US Consumer Expenditure Survey); and (3) subtract local retail expenditures from retail sales at local establishments to determine if there is a retail inflow or outflow.

The potential for new retail development in Milton Freewater will be supported by local households and related buying income, along with the potential to intercept tourism spending “inflow” and “inflow” from Washington State residents making tax free purchases in Oregon. Over the long-term, if Milton Freewater were to capture 10% of future growth in county retail expenditures, Milton Freewater could support approximately 145,000 square feet of new or rehabilitated commercial space, as indicated in Table 11. This amount of projected retail demand translates into approximately 3 to 5 net buildable acres, and up to 7 gross acres.

Table 11. Milton Freewater Retail Buying Power and Supportable Land Needs, 2005 to 2025

Store Group	Distribution of Local Income Retail Expenditures	2025 Retail Sales from County Residents	2000-2025 Retail Sales Growth Potential	Milton Freewater Proj. 10% Capture Rate	Supportable Sq. Ft. @ \$225 Annual Sales/Sq.Ft.	Supportable Building Sq. Ft. at 2 FAR*	Supportable Acreage (Net)
Food and Beverage Stores	8.3%	\$109,023	\$12,935	\$1,293,471	5,749	28,744	0.66
Food Service and Drinking Establishments	5.0%	\$65,677	\$7,792	\$779,199	3,463	17,316	0.44
General Merchandise	5.5%	\$72,244	\$8,571	\$857,119	3,809	19,047	0.44
Furniture and Home Furnishing and Electronic Appliances	2.2%	\$28,898	\$3,428	\$342,848	1,524	7,619	0.17
Motor Vehicle and Parts Dealers	9.6%	\$126,099	\$14,961	\$1,496,063	6,649	33,246	0.76
Other/Misc.	11.3%	\$148,429	\$17,610	\$1,760,991	7,827	39,133	0.90
Total	41.9%	\$550,370	\$65,297	\$6,529,691	29,021	145,104	3.33

Analysis by Otak, Inc., *FAR = Floor area ratio; the amount of land area to building floor area.

For downtown Milton Freewater, the most favorable retail growth potential appears to be within the miscellaneous retail, and food and beverages categories. However, some general merchandise will also be supported by increased retail sales. The other/miscellaneous category could possibly include a modest-sized lodging facility and/or an additional independent bed-and-breakfast, which could potentially be added to support regional visitation trends.

Tourism and visitation spending plays an important role in supporting commercial development in Umatilla County and is accredited for supporting 1,720 jobs. As shown in Table 12, total-direct spending has more than doubled between 1991 and 2003 – increasing to over \$103 million per year. The fastest growing segments that were supported by tourism spending over the 1991-2003 time period included “arts, entertainment and recreation” and “accommodations and food service”.

Table 12. Umatilla County Travel and Tourism Impacts, 1991-2003**

	1991	1998	1999	2000	2001	2002	2003	% Change '91-'03
Total Direct Travel Spending (\$Millions)								
Visitor Spending at Destination	42.4	74.2	80.4	91.4	90.7	96.3	102.3	141%
Other Travel*	0.6	1.0	1.1	1.2	1.1	1.1	0.7	17%
Total Direct Spending	43.1	75.2	81.5	92.5	91.8	97.3	103.0	139%
Visitor Spending by Type of Traveler Accommodation (\$Million)								
Hotel, Motel	16.6	28.7	31.8	37.6	36.5	41.1	43.9	164%
Private Campground	7.2	9.4	9.8	10.6	10.8	10.6	11.4	58%
Public Campground	2.0	2.2	2.3	2.4	2.5	2.5	2.6	30%
Private Home	6.6	8.1	8.7	9.8	10.0	9.6	10.3	56%
Vacation Home	1.4	3.1	3.5	4.2	4.3	4.3	4.6	229%
Day Travel	8.6	22.7	24.2	26.8	26.5	28.1	29.5	243%
Spending at Destination	42.4	74.2	80.4	91.4	90.7	96.3	102.3	141%
Visitor Spending by Commodity Purchased (\$Million)								
Accommodations	7.0	11.2	12.1	13.4	13.1	14.9	15.0	114%
Food & Beverage Services	8.6	15.3	16.2	17.7	17.7	19.7	20.6	140%
Food Stores	4.1	6.2	6.6	7.1	7.2	7.7	8.1	98%
Ground Tran. & Motor Fuel	12.6	14.0	16.3	21.1	20.8	19.0	23.1	83%
Arts, Entertainment & Recreation	2.9	17.7	18.8	20.8	20.6	22.9	23.7	717%
Retail Sales	7.0	9.4	10.0	10.8	10.8	11.7	11.7	67%
Air Transportation (visitor only)	0.2	0.4	0.4	0.5	0.5	0.4	0.2	0%
Spending at Destination	42.4	74.2	80.4	91.4	90.7	96.3	102.3	141%
Industry Earnings Generated by Travel Spending (\$Million)								
Accommodations & Food Service	6.6	11.4	12.2	13.3	13.2	14.9	15.4	133%
Arts, Entertainment & Recreation	0.8	4.7	5.0	5.5	5.4	6.0	6.2	675%
Retail**	2.0	2.8	3.0	3.2	3.2	3.2	3.5	75%
Auto Rental & other ground tran	a	0.1	0.1	0.1	0.1	0.1	0.1	-
Air Transportation (visitor only)	0.1	0.1	0.1	0.1	0.1	0.1	0.1	0%
Other Travel*	0.3	0.4	0.5	0.5	0.5	0.5	0.4	33%
Total Direct Earnings	9.8	19.4	20.8	22.7	22.6	24.8	25.6	161%
Industry Employment Generated by Travel Spending (Jobs)								
Accommodations & Food Service	580	760	800	850	840	930	930	60%
Arts, Entertainment & Recreation	110	550	540	570	590	620	580	427%
Retail**	160	170	180	190	180	180	190	19%
Auto Rental & other ground tran	b	b	b	b	10	10	10	-
Air Transportation (visitor only)	0	0	0	0	0	0	0	-
Other Travel*	20	20	20	20	20	20	10	-50%
Total Direct Employment	970	1,520	1,550	1,604	1,630	1,750	1,720	77%
Tax Receipts Generated by Travel Spending (\$Millions)								
Local Tax Receipts	0.3	0.6	0.6	0.7	0.7	0.7	0.7	133%
State Tax Receipts	2.0	2.9	3.0	3.3	3.3	3.3	3.4	70%
Total Direct Tax Receipts	2.4	3.5	3.6	4.0	4.0	4.0	4.2	75%

**Source: Dean Runyan Associates

Details may not add to totals due to rounding.

*Other Travel includes resident air travel and travel agency services. **Retail includes gasoline.

Less than \$50,000 in spending, earnings or tax receipts = 'a'. Less than 5 employees = 'b'.

Office Demand

The future outlook for office job growth and land needs are forecasted to show an improvement over the next 10 years. According to the Oregon Employment Department, total Region 12 (Umatilla and Morrow Counties) employment is expected to expand to 33,720 by 2012, an increase of 2,370 jobs from 2002. If this trend continues for the subsequent 10-year period, total job growth in Region 12 will increase to 36,250.

The demand for office space in downtown Milton Freewater depends on growth in employment in the competitive market region and changes in household formations and work location preferences. As households get older, demand for professional services, such as medical, legal and financial services tends to rise. Other factors, such as availability and price of land/buildings, telecommunications and internet access also play into location decisions.

For this analysis, we have assumed office growth to be on par with household growth potential. As shown in Table 14, Umatilla County's share of Region 12 growth is expected to be approximately 80-90% of Region 12 growth, and Milton Freewater would likely capture approximately 12 percent of Umatilla County's growth. This amount of office demand would require approximately 60,000 square feet of building area, which would require approximately 6 net buildable acres of land area—assuming off-street parking is provided.

Table 13. Umatilla County Job Distribution, January 2005

Employment Sectors (Nonfarm payroll)	Umatilla County 2005	Morrow County 2005	Total Region 12 2005	Estimated Umatilla County Share of Regional Growth
Manufacturing	3,340	800	4,140	81%
Construction and Mining	870	80	950	92%
Transportation and Utilities	3,070	330	3,400	90%
Wholesale Trade	580	190	770	75%
Retail Trade	3,050	220	3,270	93%
Finance, Insurance and Real Estate	900	120	1,020	88%
Services	7,410	300	7,710	96%
Government	7,310	800	8,110	90%
Total	26,530	2,840	29,370	90%

Source: Oregon Employment Department

Table 14. Office Development Potential, Milton Freewater, 2002 to 2022

Employment Sectors (Non-farm payroll)	Proj. Jobs Region 12 2002-2022*	Umatilla Co. Capture Rate	Umatilla County Jobs	Milton Free Water Capture Rate	Milton Free Water Total Jobs	Office Job Factor	Office Jobs**	Supportable Gross Building Floor Area Req. (SF)***	Supportable Acreage (Net)
Finance, Insurance and Real Estate	348	80%	64	12%	33	0.9	30	7,507	0.69
Services	3,057	80%	548	12%	293	0.6	176	44,021	4.04
Government	862	80%	168	12%	83	0.6	50	12,418	1.14
Total	4,267		780		409		256	63,946	5.87

In the short-term (years 1-5), this commercial demand in downtown Milton Freewater could likely be accommodated in existing vacant or underutilized downtown buildings. In the longer-term, it is likely that some of the commercial office growth would require new buildings on vacant or redevelopment parcels.

SUMMARY OF MARKET FINDINGS

This analysis of market demand provides findings regarding local and regional growth trends and the existing vacant land in the Milton Freewater. Key findings contained in this memorandum are summarized in the following paragraphs.

- **Moderate population and employment growth is forecast for Milton Freewater during the next 20 years.**
- **With adequate public facilities such as health care and schools, Milton Freewater's population is projected to expand from 6,500 people today to nearly 10,000 people by year 2020.** This modest growth is expected to require at least 1,155 dwelling units.
- **Downtown Milton Freewater could compete within the region as a viable residential, retail and office location.** In the short-term, existing vacant and underutilized buildings can address office and most retail demand.
- **Steady growth in county wide tourism spending combined with moderate growth in local buying power hold promising potential for existing and new commercial, retail and lodging establishments.**
- **Redevelopment incentives should be considered to optimize long-term downtown development potential.** Local land use and fiscal policies may be considered to leverage additional private investment within downtown. Strategies may include limited tax abatement, formation of an urban renewal district, reduced parking requirements, and establishment of a foreign enterprise zone.
- **Main Street design treatments such as new sidewalks, landscaping, public art, and pedestrian amenities along with shared public parking lots can also help to re-energize downtown development potential.**

EXISTING CODE ANALYSIS

Introduction

The Milton-Freewater Zoning Code was established to “enhance the quality of life and protect the health, safety, and enhance the general welfare of the citizens of the City of Milton-Freewater.” Milton-Freewater has established seven zoning districts. The study area for the Special Transportation Plan (STP) and Transportation System Plan Update (Plan) encompasses Oregon State Highway 11, also known as Main Street, from 2nd Avenue to 14th Avenue including one block east and one block west of Highway 11. There are seven zoning districts within the study. These include: Residential Low Density (R-1), Residential Medium Density (R-2), Residential High Density (R-3), Residential Office (R-O), Retail and Service Commercial (C-1), General Commercial (C-2), and Public Lands (PL).

Figure 1.1 shows a map of the study area with the zoning districts. This memorandum is an analysis of the existing zoning code requirements for each district in the study area.

Residential Low Density (R-1)

As seen on Figure 1.1, the R-1 zoning district is located on one block on Main Street, just north of City Hall. The intent of R-1 is to provide for larger, more secluded, home site with a maximum of four units per acre.

Zoning Requirements

Use	Permitted	Minimum Lot Size	Minimum Yard Requirements	Height	Lot Coverage
Single-family	Permitted	10,000 SF	Front: 22 ft, Side: 12 ft, Rear: 22 ft	Max: 28 Ft	50% - structural
City governmental structure	Permitted		Front: 22 ft, Side: 22 feet, Rear: 22	Same	Same
Home Occupation	Permitted		Same	Same	Same
Manufactured House on individual lots	Permitted		Same	Same	Same
Church	Conditional	10,000 SF	Same	Same	Same
Planned unit development	Conditional		Same	Same	Same
School	Conditional		Same		
Golf Course, community center	Conditional	10,000 SF	Same	Same	Same

Residential Medium Density (R-2)

As seen on Figure 1.1, the R-2 zoning district is located on residential streets, a block off Main Street. The intent of R-2 is to provide a greater range of housing types and densities than R-1, while maintaining the character of a single-family neighborhood. Up to 16 units per acre are permitted in R-2.

Zoning Requirements

Use	Permitted	Minimum Lot Size	Minimum Yard Requirements	Height	Lot Coverage
Single-family	Permitted	7,500 SF	Front: 22 ft, Side: 6 ft one side – min of 16 ft combined, Rear: 18 ft	Max: 35 Ft	50% - structural
Duplex	Permitted	10,000 SF	Front: 22 ft, Side: 22 feet, Rear: 22	Same	Same
City governmental structure	Permitted		Same	Same	Same
Home Occupation	Permitted		Same	Same	Same
Manufactured House on individual lots	Permitted		Same	Same	Same
Church	Conditional	10,000 SF	Same	Same	Same
Boarding room	Conditional	9,000 SF	Same	Same	Same
Planned unit development	Conditional		Same	Same	Same
School/child care	Conditional	9,000 SF	Same	Same	Same
Golf Course, community center	Conditional	10,000 SF	Same	Same	Same
Density bonus – 8 additional units per acre	Conditional	2,700 SF/unit	Same	Same	Same

Residential High Density (R-3)

As seen on Figure 1.1, the R-3 zoning district is located mostly on southern Main Street. The intent of R-3 is to provide the widest range of housing alternatives including multi-family units. A maximum density of 26 units per acre is permitted.

Zoning Requirements

Use	Permitted	Minimum Lot Size	Minimum Yard Requirements	Height	Lot Coverage
Single-family	Permitted	5,000 SF	Front: 22 ft, Side: 6 ft one side – min of 14 ft combined, Rear: 16 ft	Max: 35 Ft	45% - structural; 80% - impervious
Duplex	Permitted	7,500 SF	Same as above	Same	Same
Boarding room	Conditional	7,000 SF	Front: 22 ft, Side: 12 feet, Rear: 22	Same	Same
Child care facility	Conditional	9,000 SF	Same as above	Same	Same
Church	Site plan review	10,000 SF	Same as above	Same	Same
Community center	Site plan review	10,000 SF	Same as above	Same	Same
Manufactured park	Conditional	3,500 SF per home site		Same	Same
Nursing Home	Conditional	2,500 SF per bed or unity	Front: 22 ft, Side: 12 feet, Rear: 22	Same	Same
Multi-family	Site plan review	6,000 SF for 1 st unit, 1,500 SF per additional	Same as above	Same	Same

Residential Office (R-O)

As seen on Figure 1.1, the R-O zoning district is located on Main Street, mostly between 7th and 9th Avenues. This zoning district is intended to encourage a compatible mix of residential development and small private or public offices.

Zoning Requirements

Use	Permitted	Minimum Lot Size	Minimum Yard Requirements	Height	Lot Coverage
Single-family	Permitted	6,000 SF	Front: 22 ft, Side: 6 ft one side – min of 14 ft combined, Rear: 16 ft	Max: 35 Ft	60% - structural; 80% - impervious
Duplex	Permitted	7,500 SF	Same as above	Same	Same
Modular home	Permitted			Same	Same
City government structure	Permitted			Same	Same
Offices	Site plan review	6,000 SF	Determined by site plan review	Same	Same
Boarding room	Site plan review	9,000 SF	Front: 22 ft, Side: 12 feet, Rear: 22	Same	Same
Child care facility	Conditional	9,000 SF	Same as above	Same	Same
Church	Site plan review	10,000 SF	Same as above	Same	Same
Community center	Site plan review	10,000 SF	Same as above	Same	Same
Manufactured housing	Permitted	3,500 SF per home site		Same	Same
Nursing Home	Conditional	2,500 SF per bed or unity	Front: 22 ft, Side: 12 feet, Rear: 22	Same	Same
Multi-family	Site plan review	6,000 SF for 1 st unit, 1,500 SF per additional	Same as above	Same	Same
Single-family converted to office	Conditional			Same	Same

Other Requirements

The intent of R-O is to all a mix of office and residential uses while still maintaining the residential character of the neighborhood. This balance must be achieved with all proposals. R-O zone is only allowed when abutted by a commercial zone, 75% of the lots are developed, and at least 50% of the uses are nonconforming in a Residential zone.

Retail and Service Commercial (C-1)

As seen on Figure 1.1, the C-1 zoning district is located on Main Street, in northern Milton-Freewater and between 9th and 13th Avenues. This zoning district is intended to provide for general retail and light service commercial uses such as hair salons, restaurants, and supermarkets.

Zoning Requirements

Use	Permitted	Minimum Lot Size	Minimum Yard Requirements	Height	Lot Coverage
Upkeep, repair, and replacement of existing uses in C-2	Permitted	Varies	Based on site plan review	Max 35 feet within 150 feet of residential zone, max. 45 feet if greater than 150 feet	50% - structural; 75% - impervious

Upkeep, repair, and replacement of existing of residential structures	Permitted	6,000 SF	Front: 22 ft, Side: 6 ft one side - min of 14 ft combined, Rear: 16 ft	Same	from residential zone	50% structural; 75% impervious
Public utilities	Permitted	Varies	Based on site plan review	Same		50% structural; 75% impervious
Retail trade	Site plan review	Varies	Same	Same		Site plan review
Office/school	Site plan review	Varies	Same	Same		Same
Financial institute	Site plan review	Varies	Same	Same		Same
Personal business	Site plan review	Varies	Same	Same		Same
Commercial amusement	Site plan review	Varies	Same	Same		Same
Church	Site plan review	Varies	Same	Same		Same
Dwelling units		Varies	Same	Same		Same
Fuel service station	Conditional	Varies	Same	Same		Same
Auto repair	Conditional	Varies	Same	Same		Same
Restaurant w/outdoor seating	Conditional	Varies	Same	Same		Same
Enclosed storage	Conditional	Varies	Same	Same		Same
Commercial use not listed above	Conditional	Varies	Same	Same		Same

General Commercial (C-2)

As seen on Figure 1.1, the C-2 zoning district is located on Main Street, between 9th and 11th Avenues.

This zoning district provides for commercial services such as auto repair and building supply outlets.

The uses in this zone involve heavier traffic than C-1 uses.

Zoning Requirements

Use	Permitted	Minimum Lot Size	Minimum Yard Requirements	Height	Lot Coverage
Upkeep, repair, and replacement of existing uses in C-1	Permitted	Varies	Based on site plan review	Max 35 feet within 150 feet of residential zone, max. 45 feet if greater than 150 feet from residential zone	50% - structural; 75% - impervious
Upkeep, repair, and replacement of existing of residential structures	Permitted	6,000 SF	Front: 22 ft, Side: 6 ft one side - min of 14 ft combined, Rear: 16 ft	Same	Same
Public utilities	Permitted	Varies	Based on site plan review	Same	Same
Retail trade	Site plan review	Varies	Same	Same	Same
Office/school	Site plan review	Varies	Same	Same	Same
Financial institute	Site plan review	Varies	Same	Same	Same
Personal business	Site plan review	Varies	Same	Same	Same
Commercial amusement	Site plan review	Varies	Same	Same	Same
Church	Site plan review	Varies	Same	Same	Same

Dwelling units	Site plan review	Varies	Same	Same	Same
Auto repair	Site plan review	Varies	Same	Same	Same
Lumber yard	Site plan review	Varies	Same	Same	Same
Service commercial	Site plan review	Varies	Same	Same	Same
Fuel service station	Conditional	Varies	Same	Same	Same
Restaurant w/outdoor seating	Conditional	Varies	Same	Same	Same
Enclosed storage	Conditional	Varies	Same	Same	Same
Commercial use not listed above	Conditional	Varies	Same	Same	Same

Public Lands (PL)

As seen on Figure 1.1, the PL zoning district includes City Hall and the Library on Main Street. The public lands zone provides for a full range of structures, services, and land uses provided by public agencies on publicly-owned land. A Site Plan Review process is used to determine some code requirements.

Zoning Requirements

Use	Permitted	Minimum Lot Size	Minimum Yard Requirements	Height	Lot Coverage
Public utilities	Permitted	Site plan review	Based another zone	Site plan review	Site plan review
Government structure	Site plan review	Same	Same	Same	Same
Public schools	Site plan review	Same	Same	Same	Same
Golf course	Site plan review	Same	Same	Same	Same

Parking Requirements

Parking is required for each use in a zoning district. The following are the off-street parking requirements by use.

Use	Parking Spaces
Residential – Single family	1 per unit
Residential – Multi-family	3 per each 2 units
Residential – Boarding house	80% guest capacity + management
Hotel	1 per room
Commercial – Retail store	1 per 400 SF
Commercial – Repair shop	1 per 600 SF
Commercial – Bank/office	1 per 500 SF
Commercial – Medical clinic	1 per 300SF + 1 per 2 employees
Commercial – Restaurant	1 per 200 SF
Commercial – Wholesale	1 per 500 SF + 1 per employee
Institutional – Nursing home	1 per 2 beds or 1 per residential unit
Institutional – Child care	2 per teacher
Institutional – Elem. school	2 per classroom
Church	1 per 5 seats or 1 per 10 feet of bench

Other Requirements

Additional parking may be required through Site Plan Review. When mixed uses occupy a structure, the total requirements for off-street parking shall be the sum of the various uses.

Bicycle Parking

A minimum of two bicycle parking spaces per use is required. One of those spaces shall be sheltered. For multi-family residences of four dwelling or more, at least one parking space per unit is required. All public and commercial parking lots shall provide a minimum of one bicycle parking space per 10 vehicle spaces. In the downtown study area, one bicycling parking space shall be required per use. Parking can be clustered for six bicycles. One cluster per block is required. Inverted "U" style bicycle parking rack is recommended. Bicycle parking must not interfere with the pedestrian walkway. A minimum of 5 feet of pedestrian space is required.

Site Plan Review Process

The site plan review process is used to determine compliance with the intent and specific development standards set in the zoning code. Specific requirements are needed for the site plan review process. Specific requirements related to transportation include:

- Pedestrian circulation shall be provided in new commercial, office, and multi-family residential developments.
- New commercial buildings shall be oriented towards the street, near or at the setback line.
- Off-street parking shall be located on the side or behind buildings.
- All site plans shall clearly show how the site's internal pedestrian and bicycle facilities connect with existing external or planned facilities.

Site and Design Standards

The site and design standards apply to all new development on Main Street between the south city limits and SE 3rd. These standards also apply to existing developments if exterior remodeling or expansion occurs. The intent of this section is to:

- Improve the quality of appearance of commercial and industrial development in Milton-Freewater.
- Ensure development is compatible with adjacent development
- Promote streetscapes that are with the desired character of the zoning districts
- Encourage crime prevention
- Increase opportunities for alternative transportation modes.
- Promote safe, attractive, and functional pedestrian circulation systems in commercial areas.

Standard	Requirement
Exterior walls	25% of wall area facing a street must have treatment with 15% being glass.
Exterior walls	Building frontages greater than 100 feet in length shall have off-sets or distinct changes in the building façade.
Landscaping	15% of site shall be landscaped. 80% should be live plant material, 20% may be natural features.
Off-street parking	Perimeter landscaping of 4-feet required in all parking areas.
Exterior lighting	Lighting shall have minimal adverse effects on adjacent residential properties.

Supplementary Provisions

Chapter 5 of the Zoning Code includes supplementary provisions for Access Management and Connectivity. These provisions apply to Main Street. They include:

- Shared parking is permitted and a reduction of required spaces if peak demands do not occur at the same time.
- One-way driveways should have a minimum of 10 feet in width.
- Two-way driveways shall have a minimum of 10 feet and maximum of 12 feet in width.

MAIN STREET EVALUATION WORKSHEET SUMMARY

	GOOD	FAIR	POOR
COMFORT AND IMAGES			
• Clean, well maintained	1	11	3
• Feels safe		11	2
• Human scale	1	9	2
• Attractiveness		5	8
• Places to sit			15
VISUAL AND PHYSICAL ACCESS			
• Identifies downtown	1	8	5
• "Walkable"	3	9	2
• Connection to adjacent buildings and neighborhood	1	7	5
USES AND ACTIVITIES			
• Variety of things to do	1	6	7
• Attractive to different ages		6	8
• Fun		4	11
• Special/unique	1	3	11
• Has local character and uses	1	6	7
SOCIABLE			
• Social interaction (talking, holding hands, kissing)	1	3	10
• People in groups		5	9
• Sense of place		5	9

COMMENTS FROM WALKING TOUR

A. What do you like best?

1. The well maintained old buildings
2. City Hall/Library district is very nice
3. Historic buildings although some are run down
4. La Mona's dress shop. The old library could be a nice gathering place if decorated attractively from the outside.
5. The potential to have a nice area that will make people want to stop and shop.
6. At north end of the District – City Hall/Library – old library
7. There is a lot of potential – defiantly room for improvement. Historical buildings – street is wide so there is room for reconfiguring the way it all works.
8. Commercial not retail, more retail to South Columbia, leave hwy 11 a highway
9. The old library building
10. Accessibility and friendly shop personnel.
11. The older buildings.

12. Areas where there are grass and trees.
13. Parking strips in some areas and wide sidewalks
14. Many different shops in small area
15. Not on foggy days, but other times we see open views, emphasize views. Like ringing church bells.

B. List three improvements that could be done right away and that wouldn't cost a lot of money?

1. Trees, project sidewalks into street and stop light, and clean up or remove old buildings
2. Develop a South main business organization, work toward capitalizing on Walla Walla's tourist direction – give the wine tour folks a reason to come here, and more greenway in bare districts.
3. Establish seasonal hanging flowers, establish tree network, and abate abandoned/run down structures.
4. Put planters on hanging baskets on streets on both sides of city hall, paint outsides of business buildings with a theme so they are noticed, and suggest that even parking lot fence be decorated on other types of fence to be more attractive
5. Paint buildings, make store windows more appealing, and add more buildings to Historic designations.
6. Explore possibilities for visual improvement of security fencing at Sallee Chevrolet, ask land owner/tenant to remove stored vehicles and trailer from old service station immediately south of Sallee Chevrolet, and pedestrian signals at 12th and 8th.
7. Tree planting in commercial areas, outside seating, and bulb outs and perhaps traffic lights at corners
8. Stop lights 9th Street, improve buildings, and landscape.
9. Adding vegetation to the southern most part of south main, benches, and tap into the developing wine culture.
10. Pedestrian cross walks and plantings along Sallee's fence
11. Awnings, trees and flowers, and fix sidewalks
12. Street lights – flashing crosswalks, rounded out corners to make pedestrians more visible to traffic, landscaping to beautify downtown
13. Re-stripping to three lanes, create "walls" as discussed on tour, and pocket park or plaza adding seating areas throughout
14. Repaint crosswalks to send better message, ID crosswalks and require traffic to stop, add benches, and consider one traffic light near center.
15. Trucks carrying dirt, etc. should be covered, lots of benches, and people need things to watch, create a traffic circle

C. What changes would you make in the long term that would have the biggest impact?

1. Buildings with retail on street level with apartments above, sidewalk dining.
2. Move away from parallel parking to allow more cars in busy areas (between 10th and 12th for example). Incentives to improve building fronts and give more of a "district" flavor. Streetlamps/hanging flower baskets/main street theme signs.
3. Traffic control services and new antique street lighting system.

4. Could the truck route be re-routed to one of the other streets so there isn't so much noisy traffic. The block south of trip zip could be a mini mall with small attractive shops that would attract tourists.
5. New sidewalks with bulb outs, trees and benches, old fashioned street lights, re-do store fronts like Dayton, WA so they portray a sense of consistency, and add brick raises to street crossings.
6. Pedestrian crossing signals (retain four lanes but shorter crossing length by width of parallel parking zone on each side of street and ????? street trees.
7. Incentives for business owners to improve the store fronts – and restore historic buildings. New street lighting – whatever we need to do to slow traffic down and make main street more pedestrian friendly and safe.
8. Stop lights and street beautification
9. Developing a real town theme, frogs may not cut it, this should be expanded on to involve something that people are actually interested in. Perhaps a beer and frog leg restaurant or a frog museum, etc. The problem is M-F doesn't have much in the way of frogs. If people actually stopped here because there is a neon frog on the water tank I think they would expect something more.
10. The Carnegie building needs to be used. Chamber of Commerce? Small coffee shop, gift shop with unique local products – a gathering place for locals plus a welcome for travelers.
11. Truck only by pass and stop sign at south of town.
12. Common theme and design for downtown area that sets it apart.
13. Redevelopment of historic as well as newer buildings, bulb out for pedestrians, and lit pedestrians crosswalk (lights inserted in pavement)
14. Move to unify store fronts if only in paint or color combo and curb extensions.
15. By pass for trucks, create boulevard: wide trees (right kind of trees) awnings, keep line of sight openness, consumer shops – for strolling. Checker board (fixed) talks, cycling path, small theater, ARTV center.